

Assembly Instructions

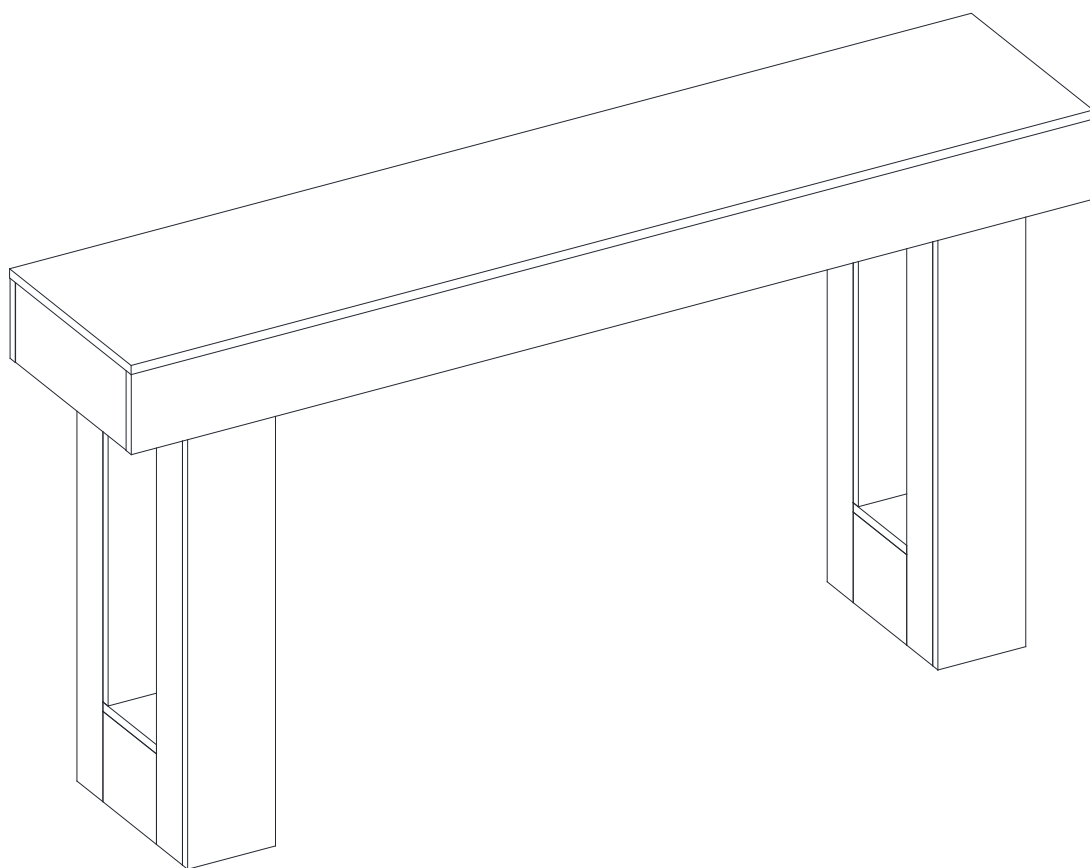

Console Table

Model No.
**JW0909/JW0936/
JW0967/JW0975/JW1022**

Contact Us

We're here to help you.

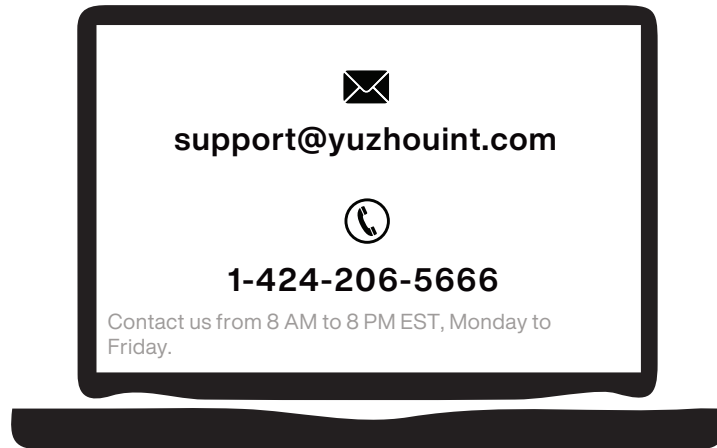

Your satisfaction is our top priority. If you encounter any issues with this product, such as missing or damaged parts, we're here to help. Please retain the original packaging and take photos of the packaging and the product, then contact us as soon as possible.

Warm Tips

1. Carefully read these instructions and keep them for future reference.
2. Check the parts list and confirm everything's there before starting assembly.
3. When assembling, put all parts on a soft, smooth surface like a carpet to avoid scratches.
4. Don't fully tighten screws until all parts are confirmed in place to avoid misalignment.

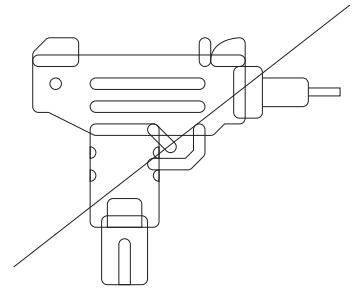
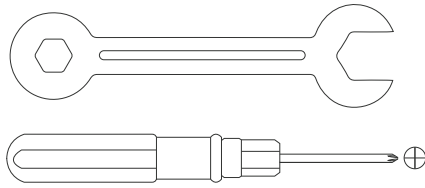
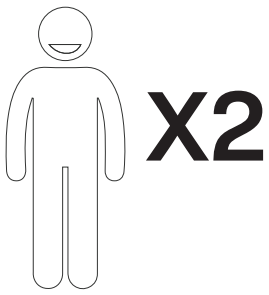

We recommend using hand tools for assembly.

If an electric screwdriver is used, reduce power and torque to avoid damage to the product.

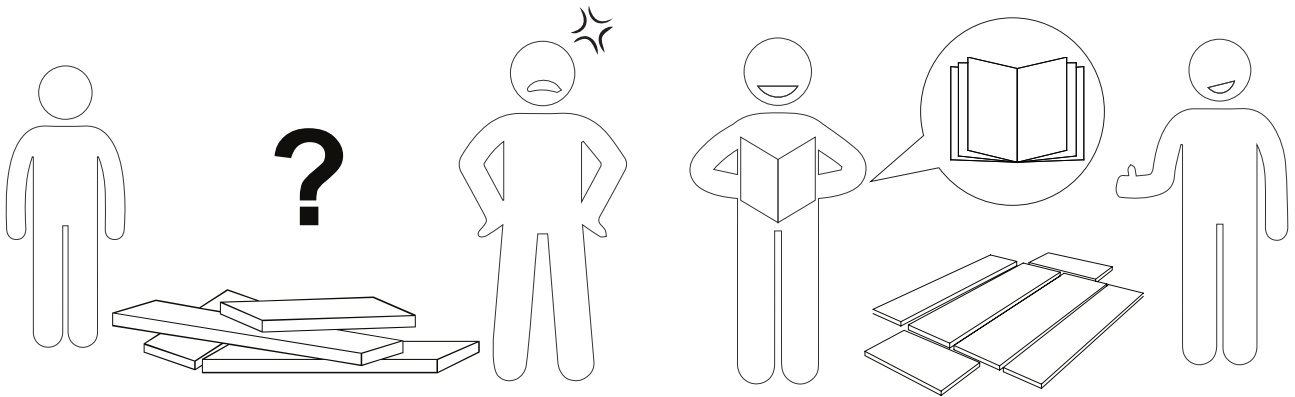

Install the Anti-Tip Straps

Using the anti-tip straps can reduce the risk of tipping over, but can not eliminate it.

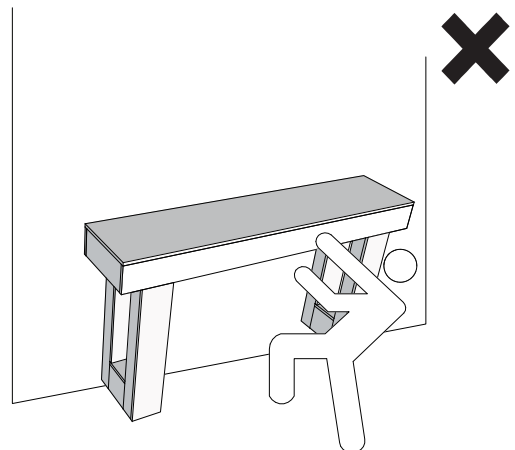
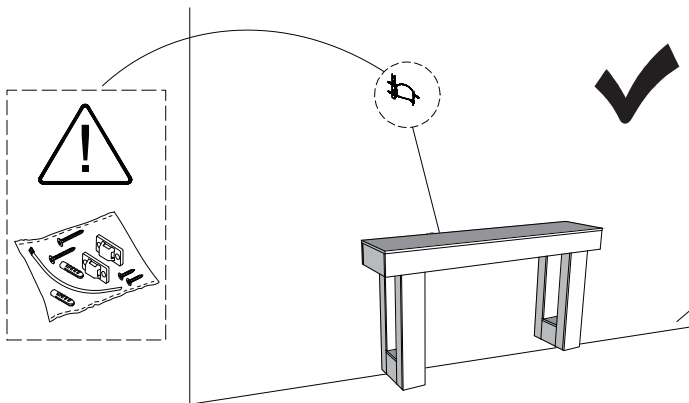

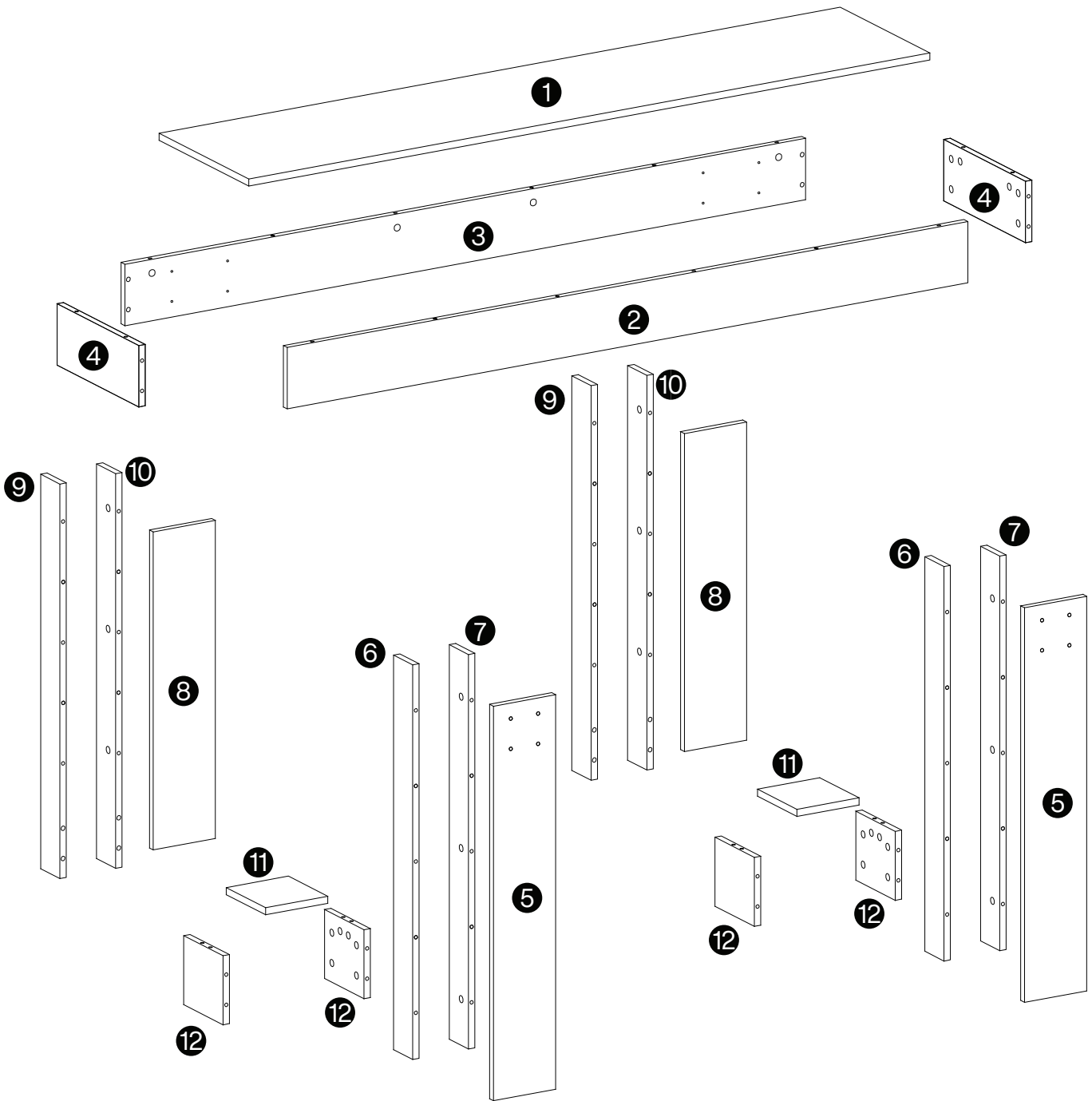



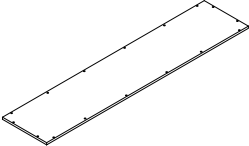
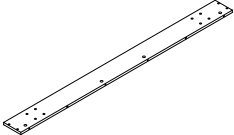
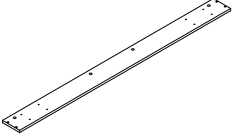
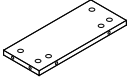
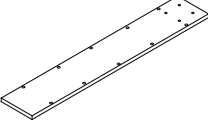
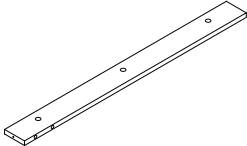
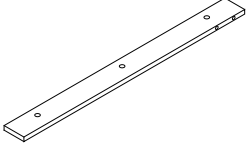
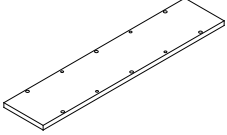
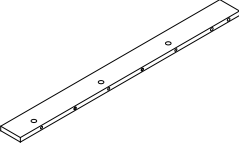
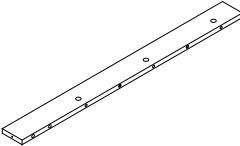
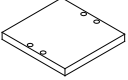
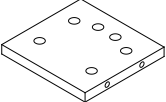

⚠ Caution

Make sure all parts are included. Most board parts are labeled or stamped on the raw edge. Contact us for a free replacement if you encounter any damaged or missing parts.

Parts List

| | | | | |
|--|--|---|---|--|
|  1 1pc |  2 1pc |  3 1pc |  4 2 pcs |  5 2 pcs |
|  6 2 pcs |  7 2pcs |  8 2 pcs |  9 2 pc |  10 2 pcs |
|  11 2 pcs |  12 4 pcs | | | |

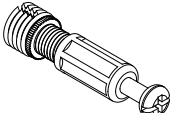
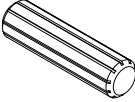
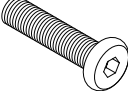
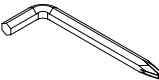
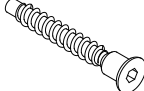
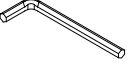
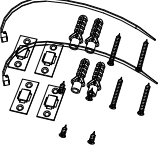
Hardware List

| A | B | C | D | E | F | G |
|---|---|---|---|--|---|---|
|  |  |  |  |  |  |  |
| φ15x12mm | M6x40mm | φ8x30mm | M6x25mm | M4 | M5x38mm | M3 |
| 68 pcs | 68 pcs | 20 pcs | 8 pcs | 1 pcs | 8 pcs | 1 pcs |
| H | I | | | | | |
|  |  | | | | | |
| 1 pc | 8 pc | | | | | |

Installation of Cams "A" and Pins "B"

First, unscrew the rubber particles of component "B" counterclockwise, and then press the rubber particles firmly onto the corresponding holes on the board. "Note that they need to be fully pressed into place".

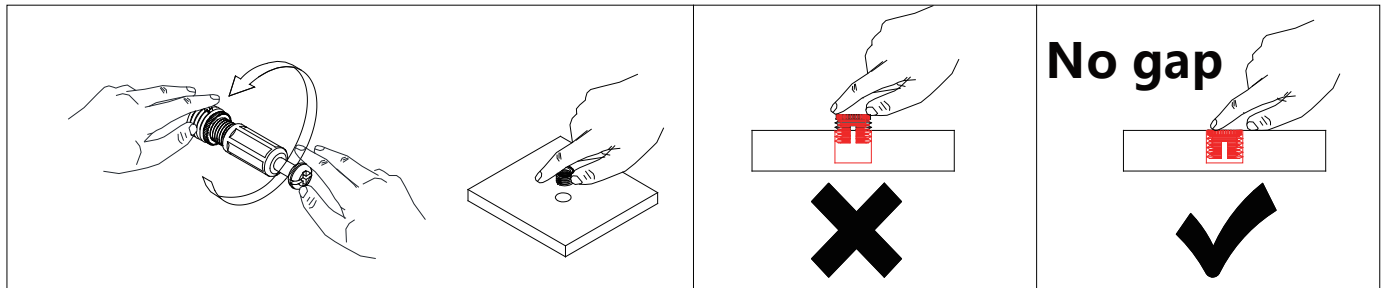

Align the screw of component "B" and tighten the adhesive particles that have been pressed onto the board clockwise.

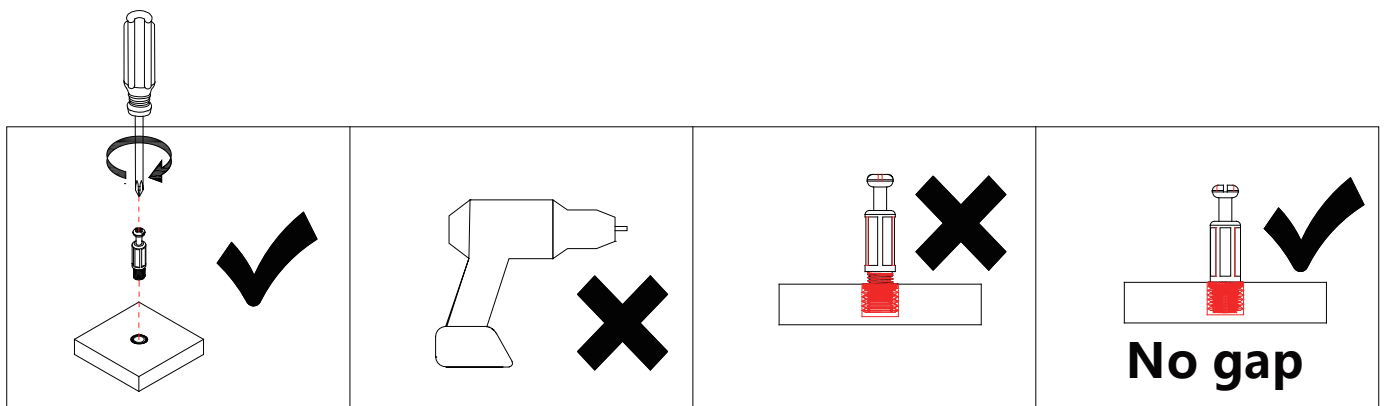

Screw the pin into the hole. To set the cams correctly, ensure that the arrow on the cam is opening to the hole of the pin it is locking. Lock the cam by turning the cam head with a screwdriver until it is tightened. Please do not use an electric screwdriver to assemble the unit.

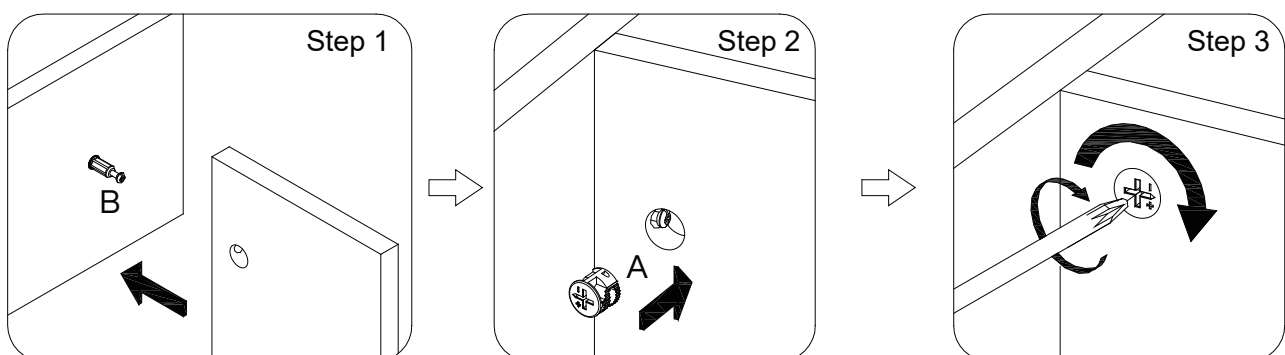

1

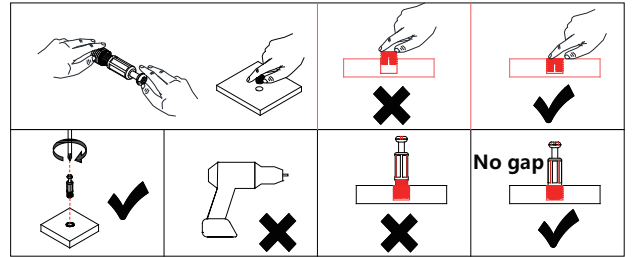
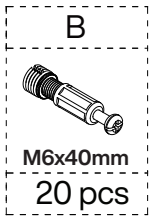
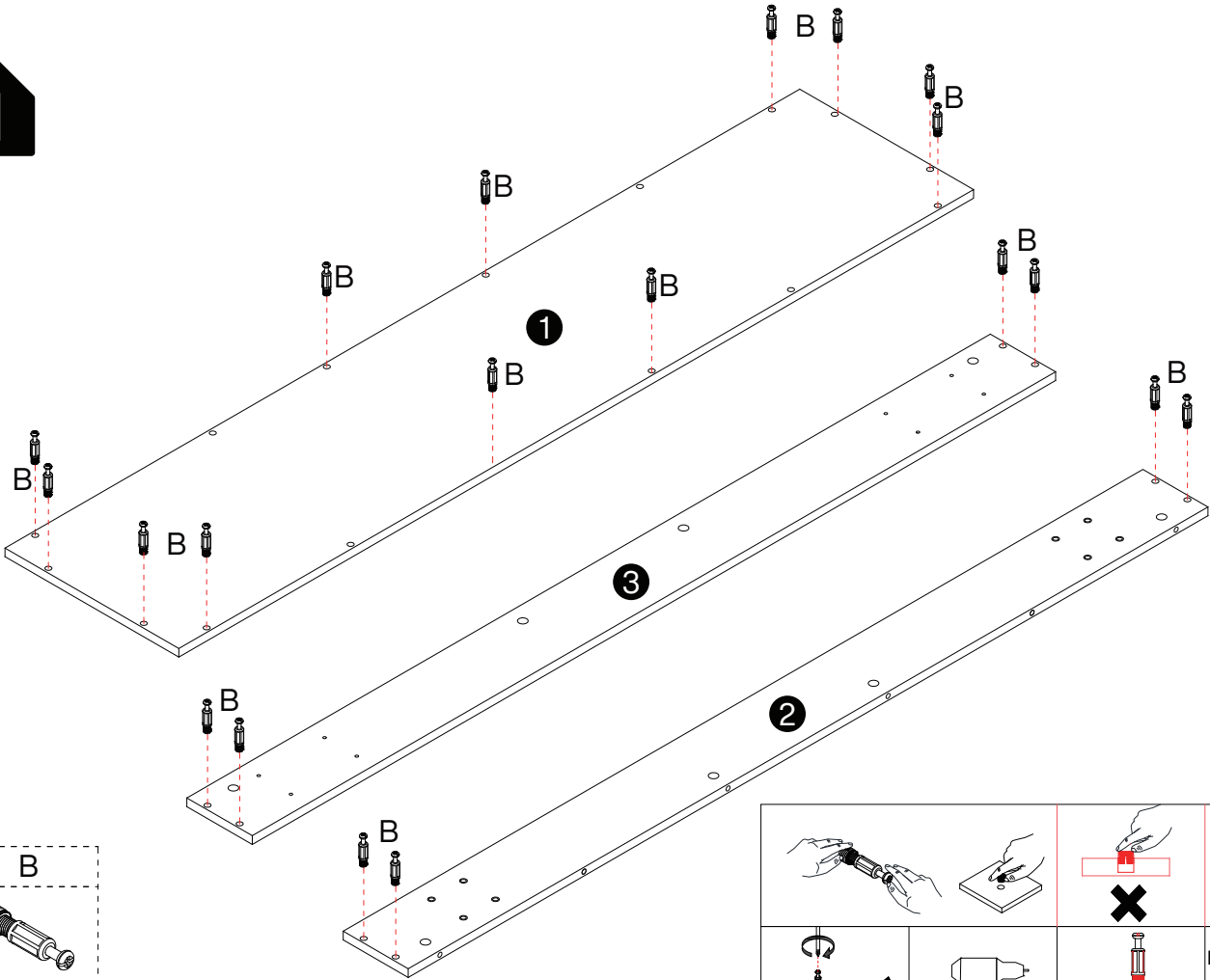

2

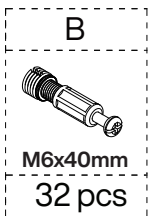
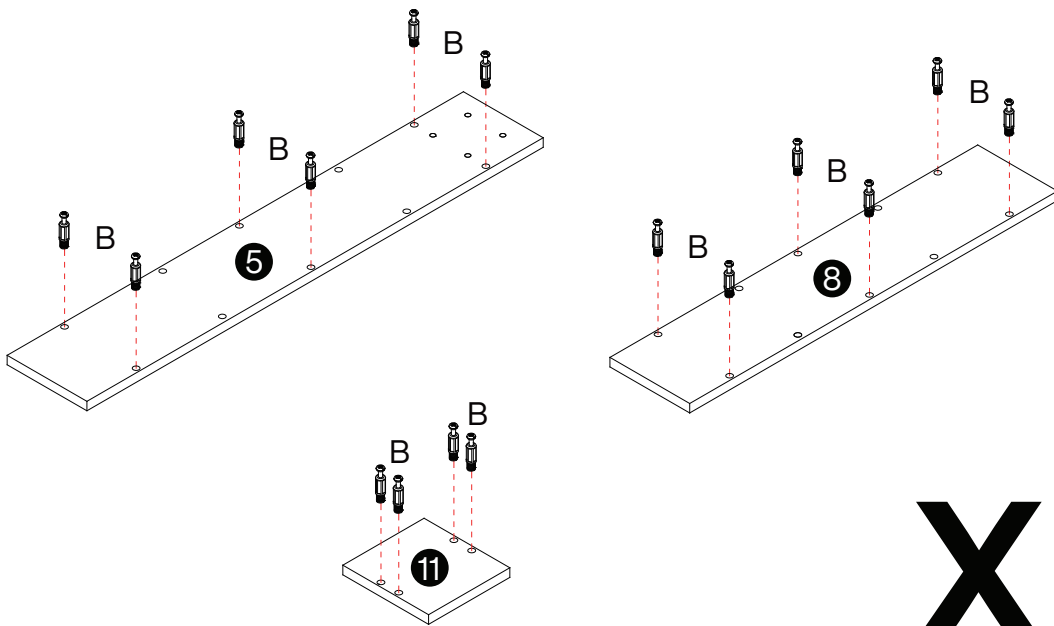

X2

3

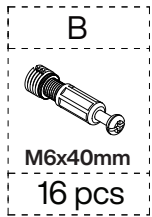
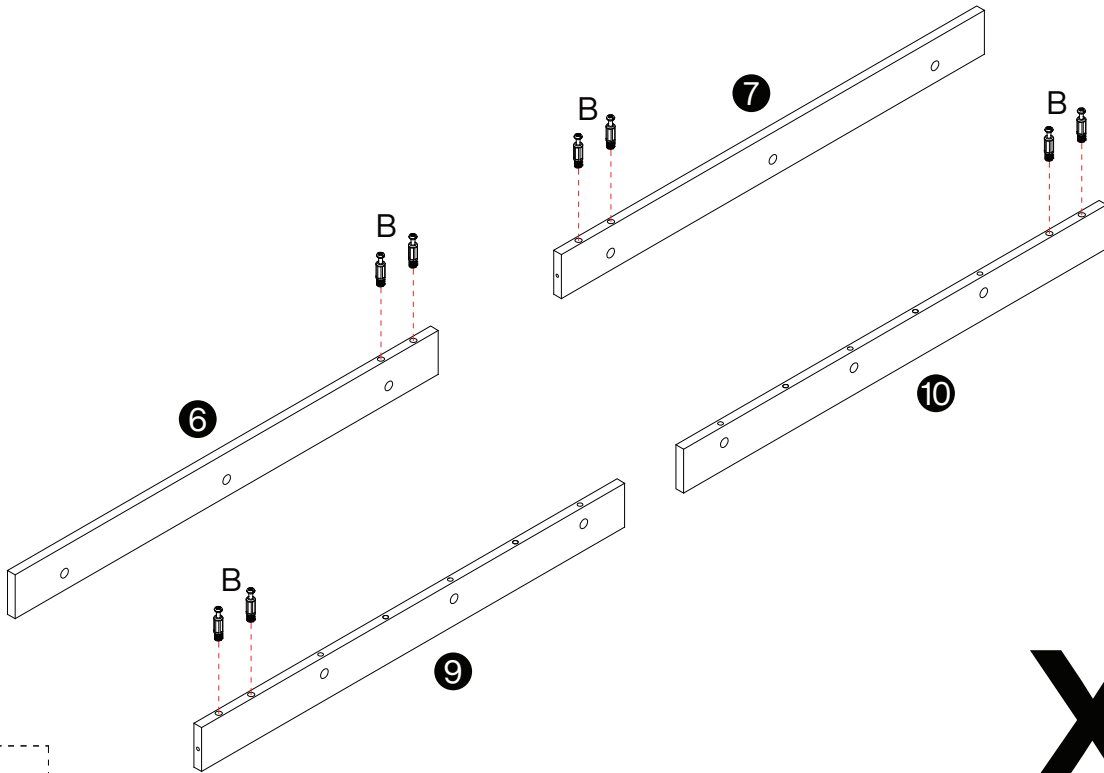

X2

4

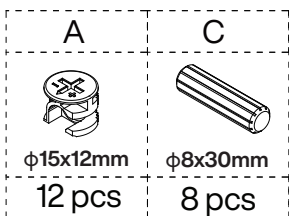
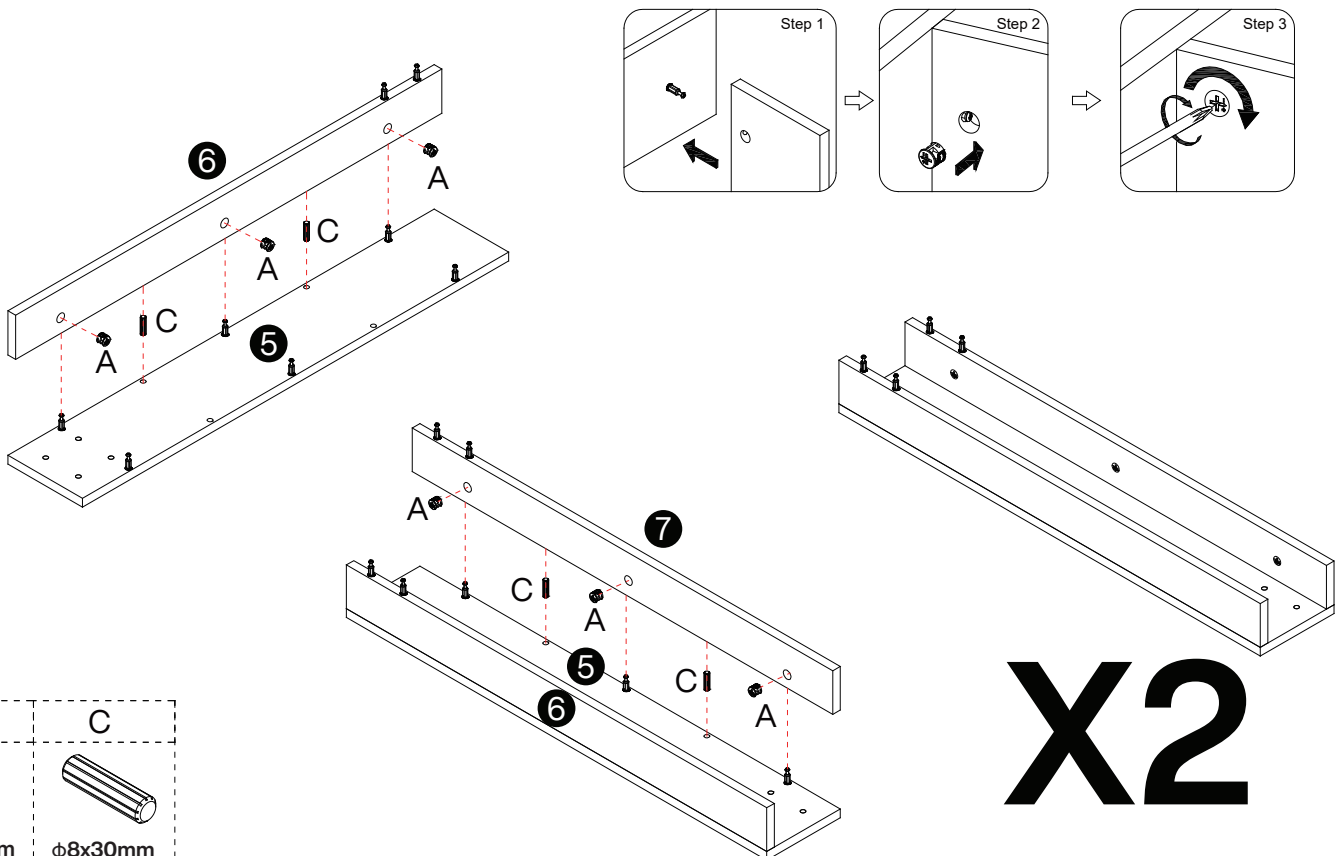

X2

5

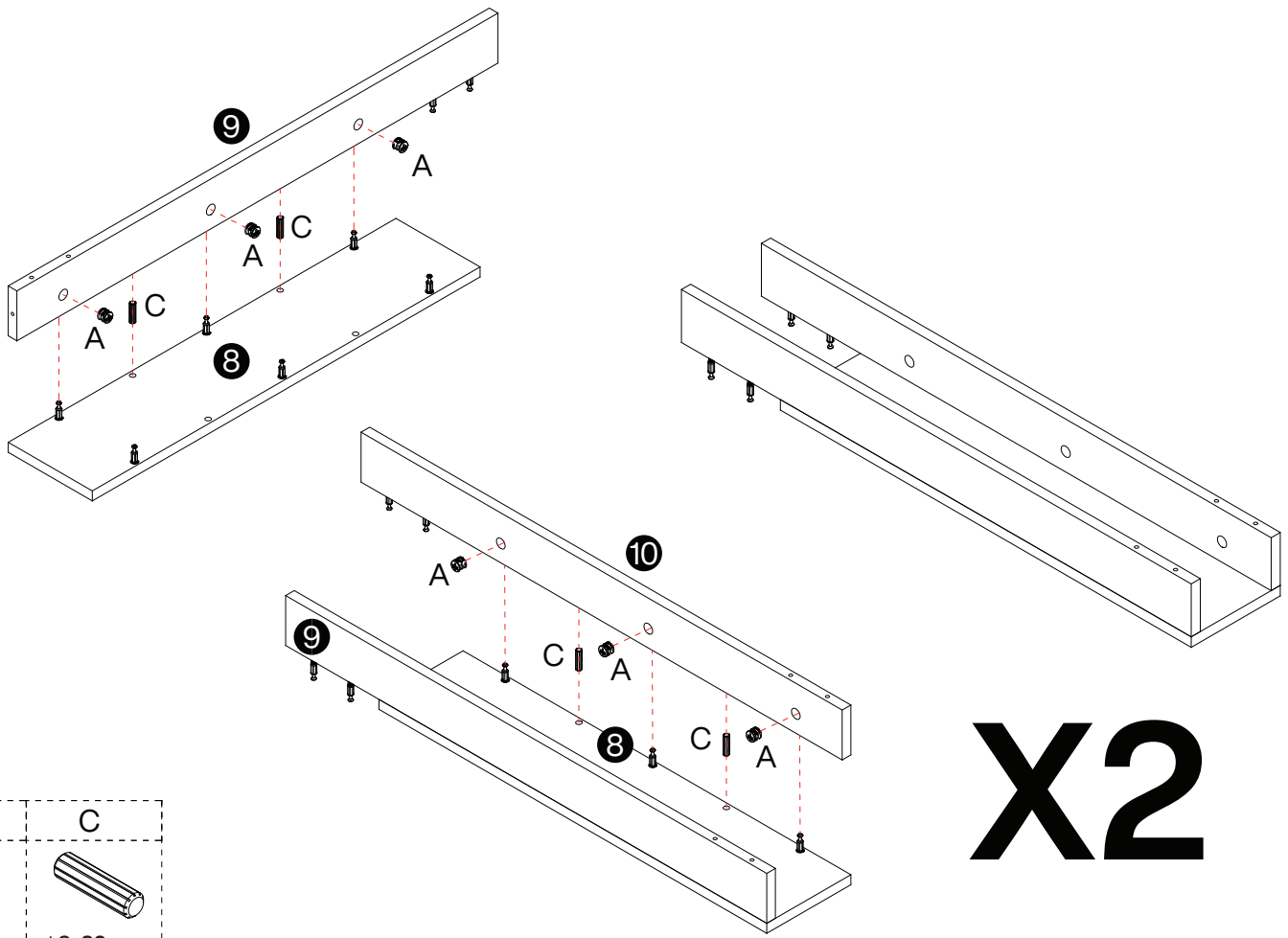

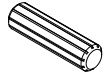
| | |
|---|---|
| A | C |
|  |  |
| $\phi 15 \times 12 \text{mm}$ | $\phi 8 \times 30 \text{mm}$ |
| 12 pcs | 8 pcs |

X2

6

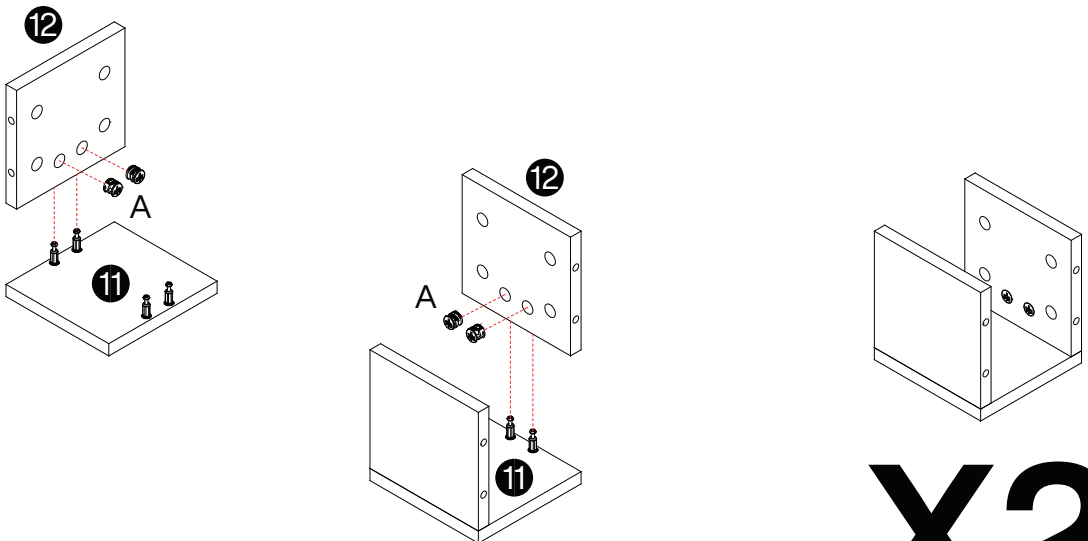

| |
|---|
| A |
|  |
| $\phi 15 \times 12 \text{mm}$ |
| 8 pcs |

X2

7

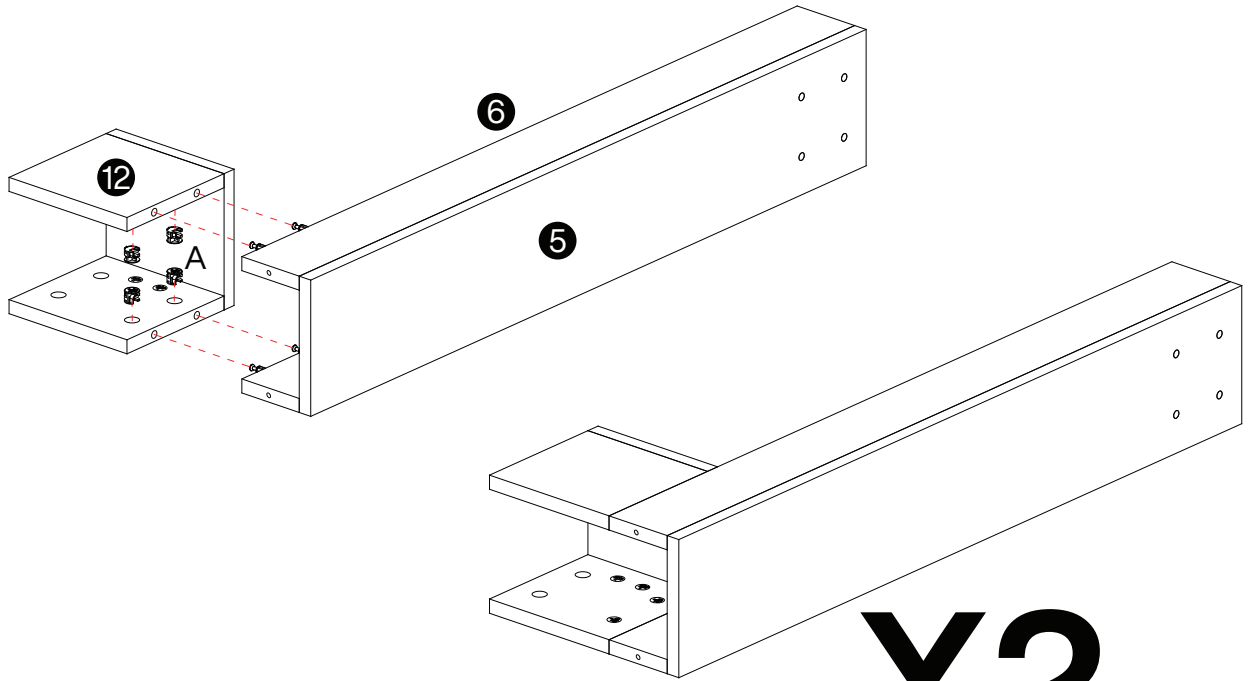

X2



8

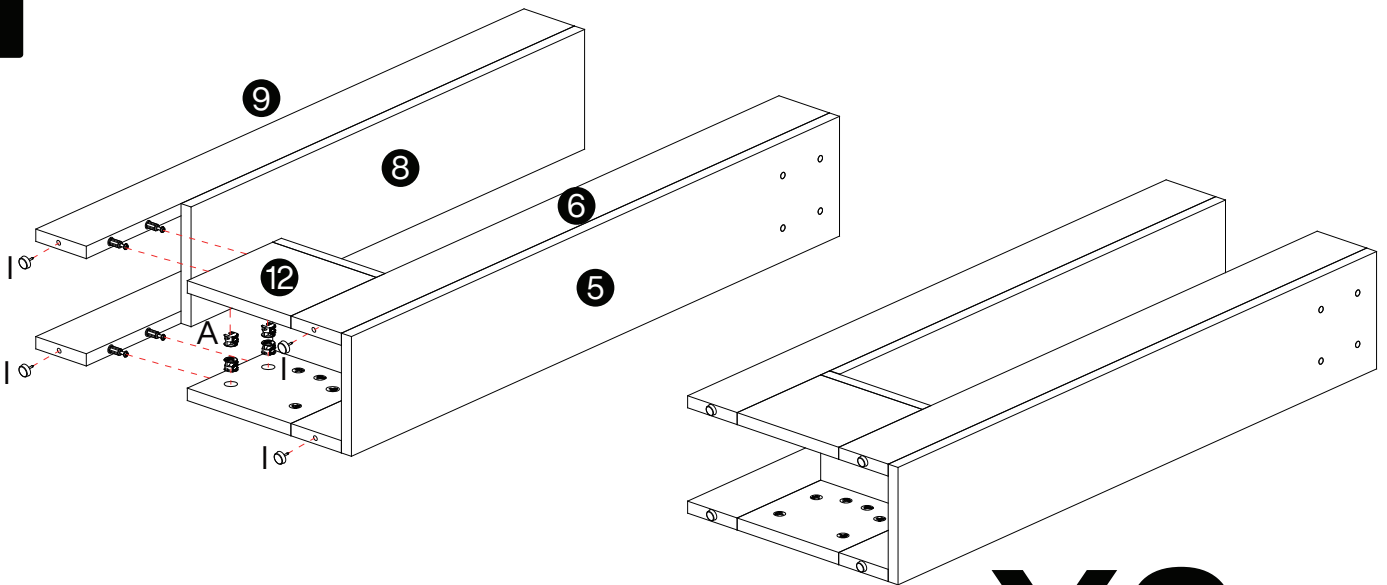

X2

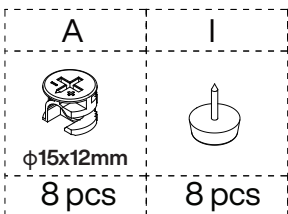

9

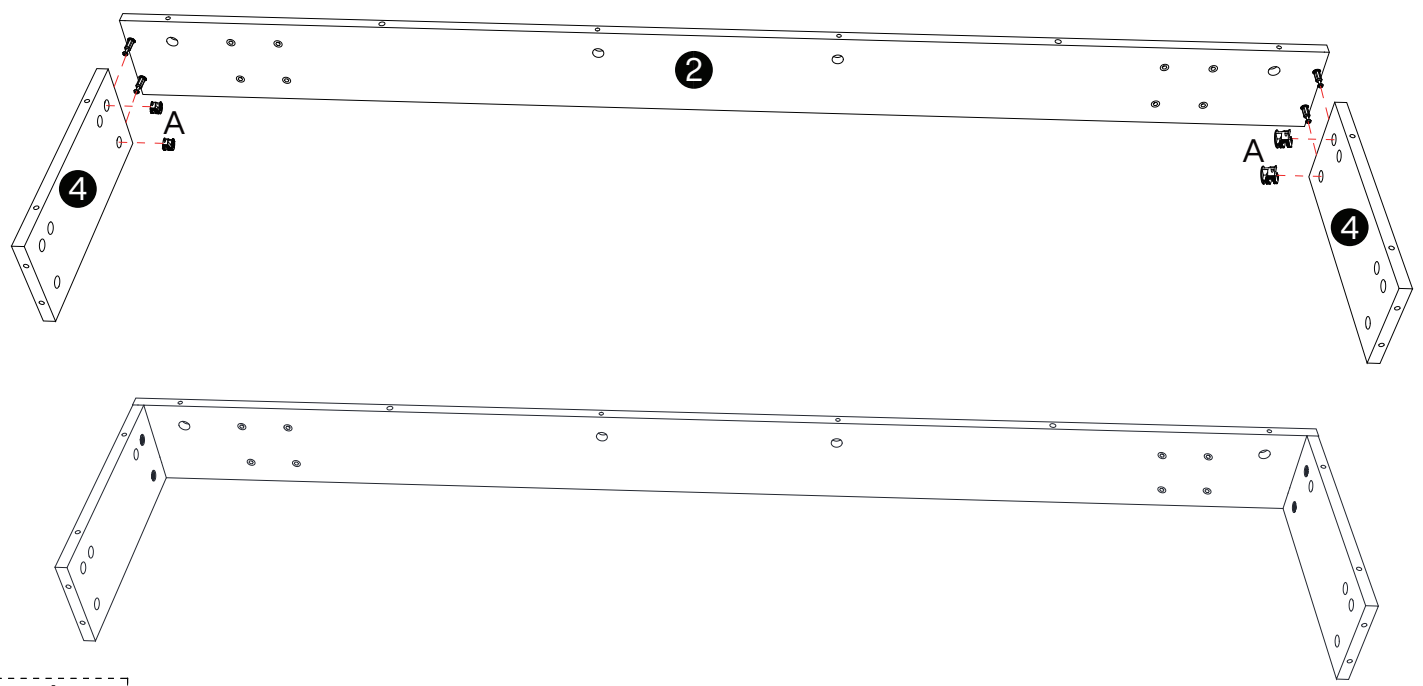

A

$\phi 15 \times 12 \text{mm}$
4 pcs

10

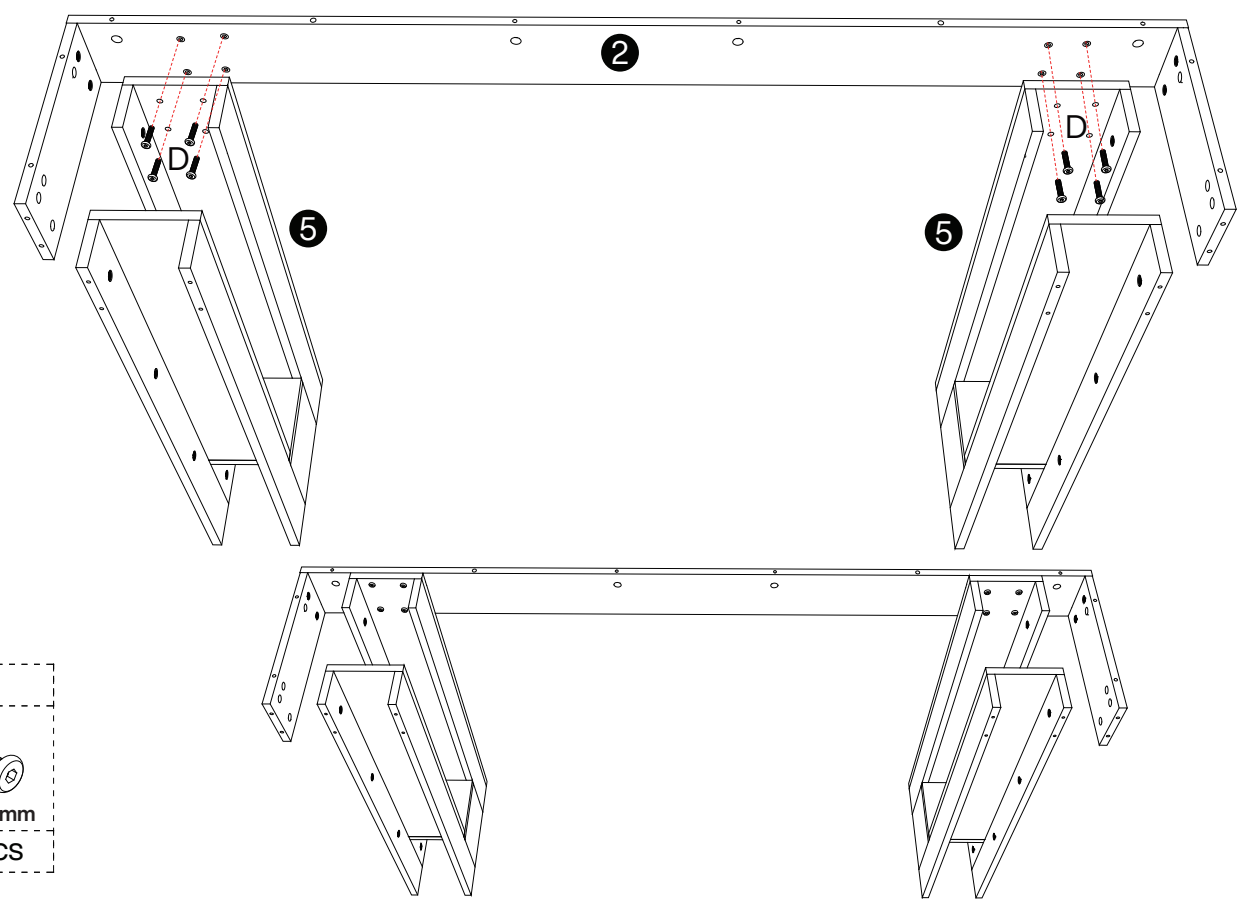

D

M6x25mm
8 pcs

11

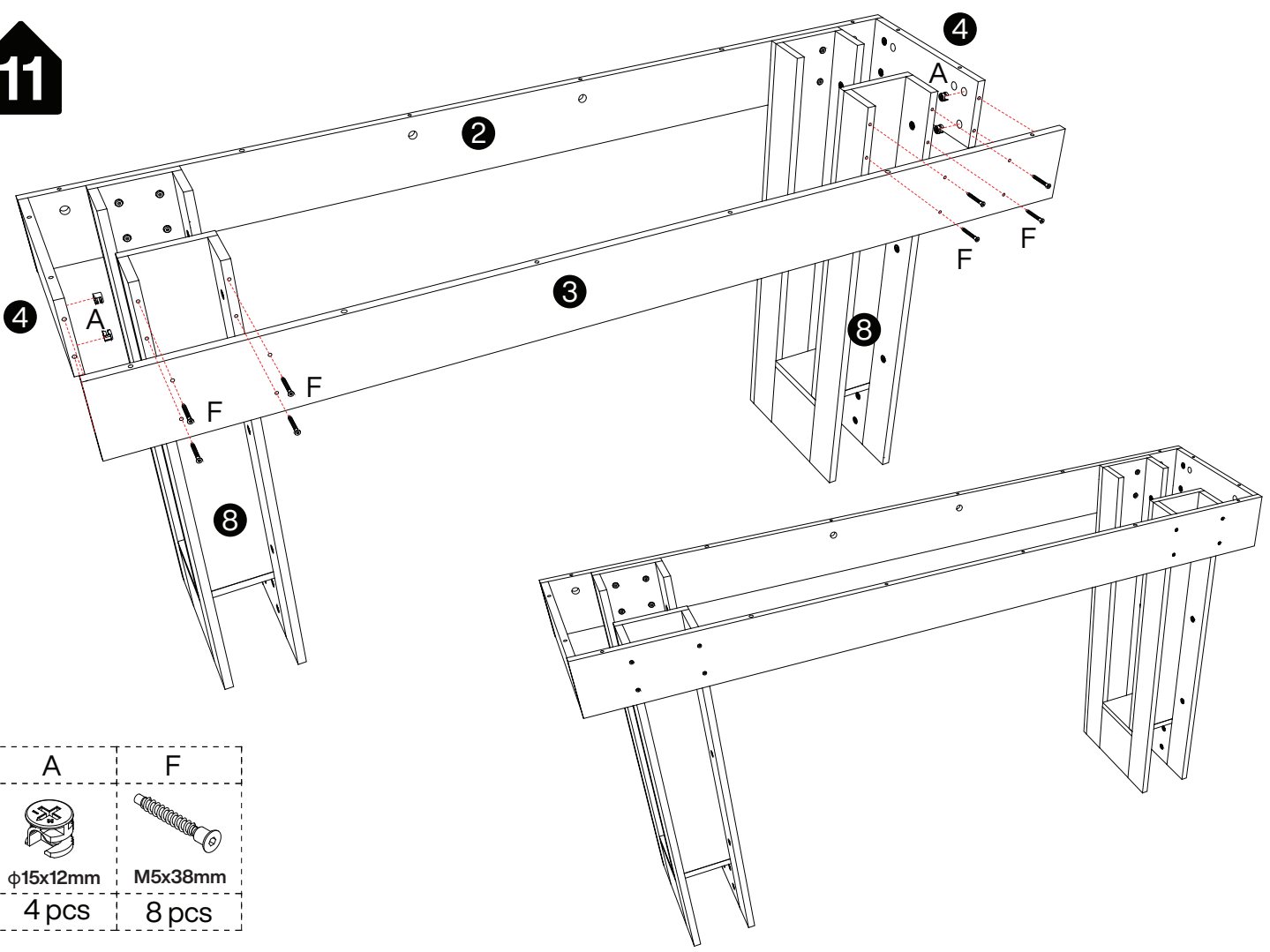

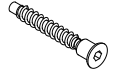
| | |
|---|---|
| A | F |
|  |  |
| $\phi 15 \times 12 \text{mm}$ | M5x38mm |
| 4 pcs | 8 pcs |

12

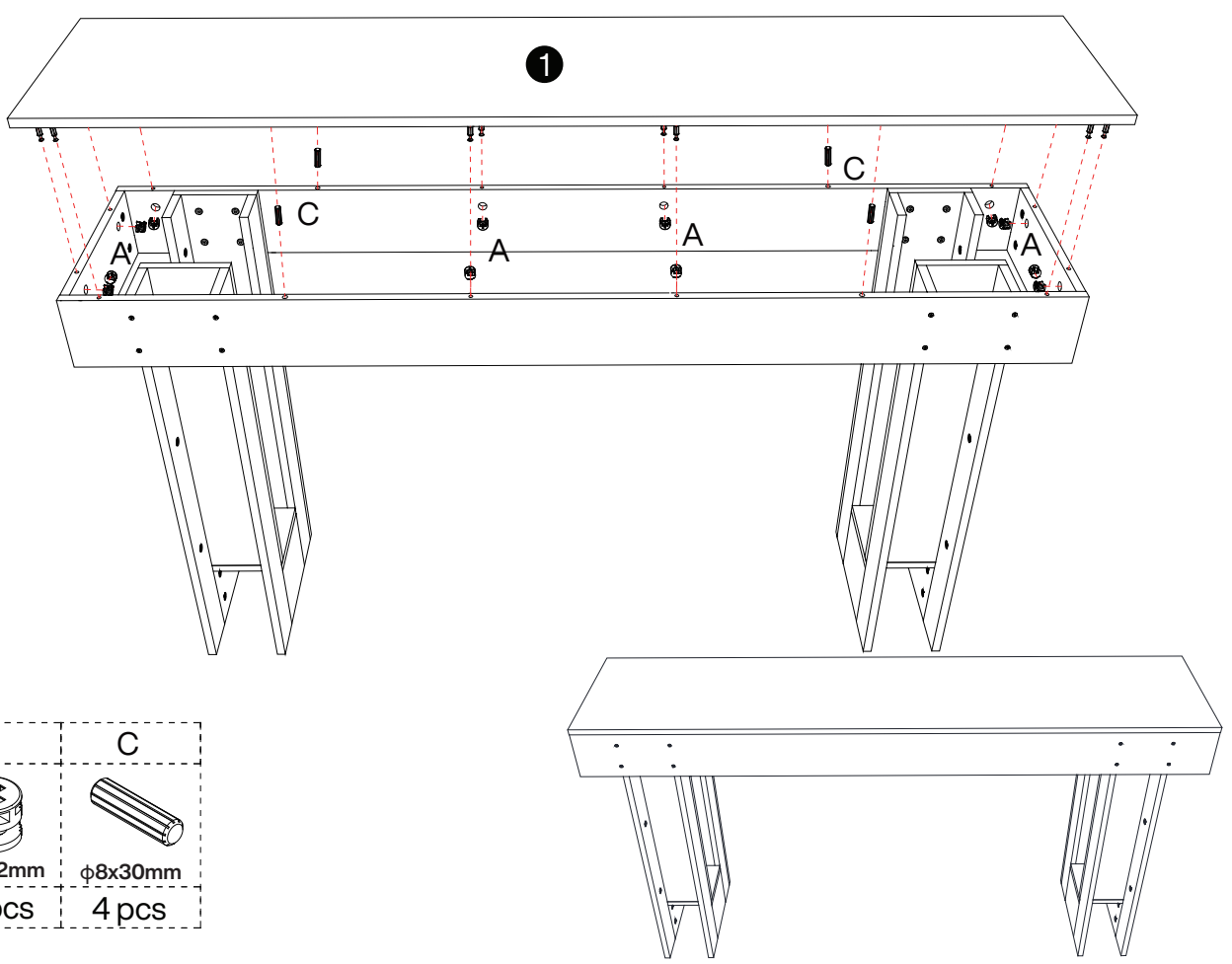

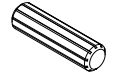
| | |
|---|---|
| A | C |
|  |  |
| $\phi 15 \times 12 \text{mm}$ | $\phi 8 \times 30 \text{mm}$ |
| 12 pcs | 4 pcs |

13

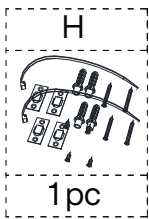
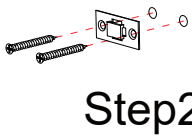
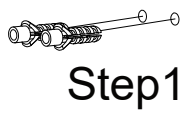
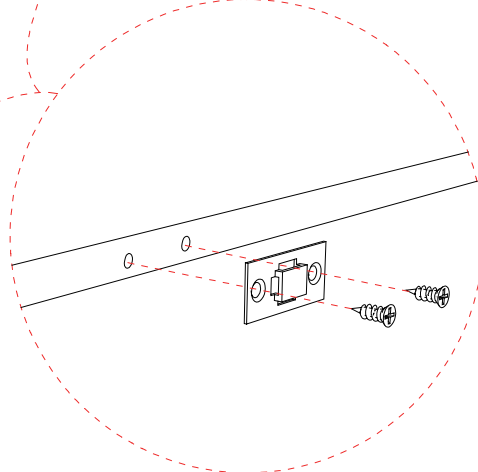
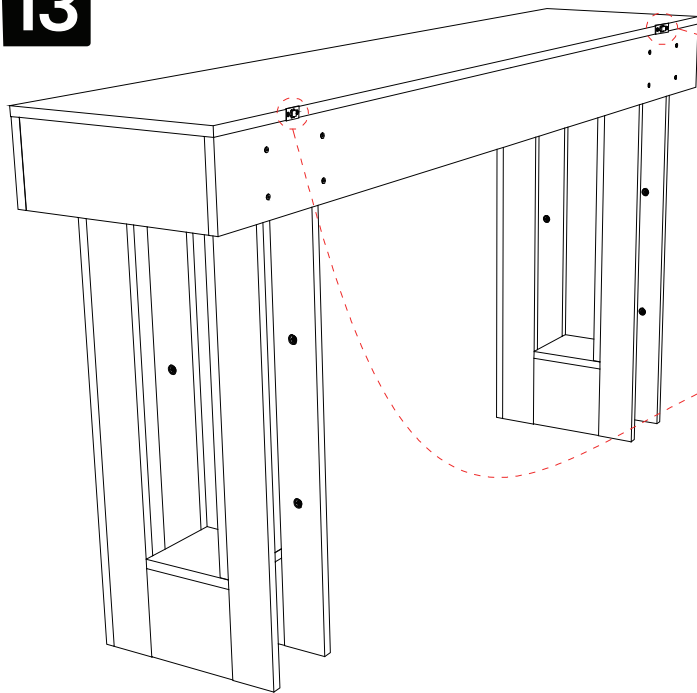

14

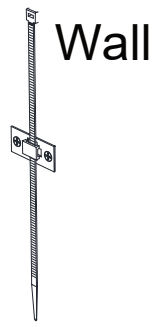
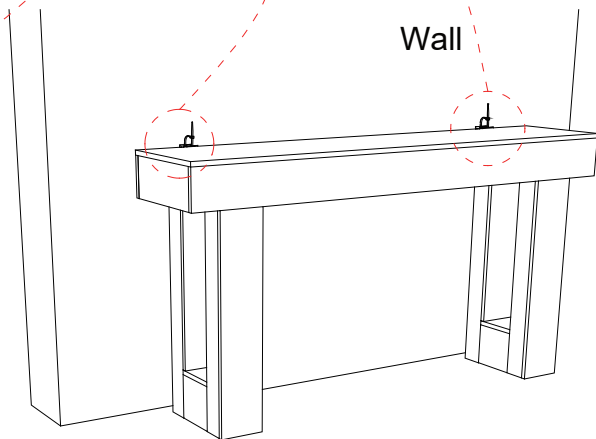
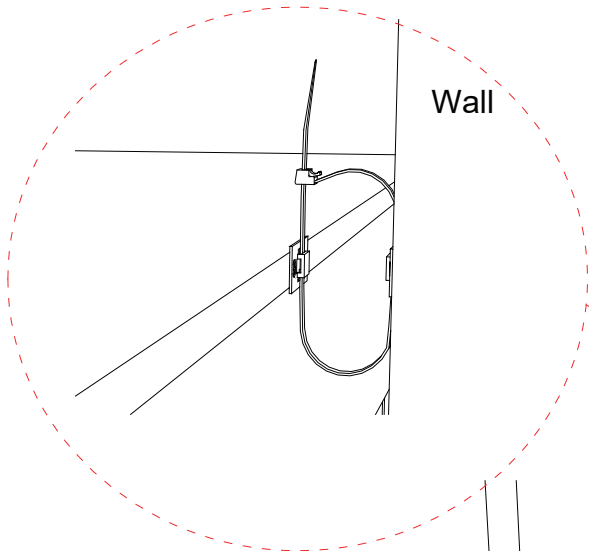

Step3

Thank you for your support!

