







ASSEMBLY INSTRUCTIONS

**MODEL : 30500-C
SADDLE STOOLS**

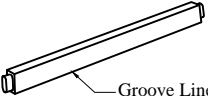
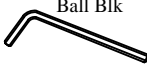
No	Part List	Qty
A	Seat 	1 pc
B	Side Frame Leg 	2 pcs
C	Front Apron 	2 pcs
D	Front Stretcher 	2 pcs

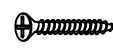
No	Hardware List	Qty
1	Allen Key m4x110mm With Ball Blk 	1 pc
2	Unita Screw M7x48mm 	8 pcs
3	Flat Head Chipboard Screw m4x32mm Rbw 	6 pcs
4	Wood Button D14.5mmxH9mm 	8 pcs

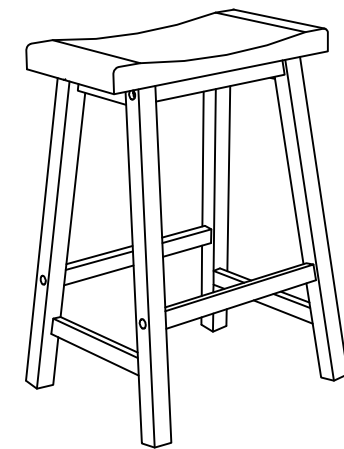
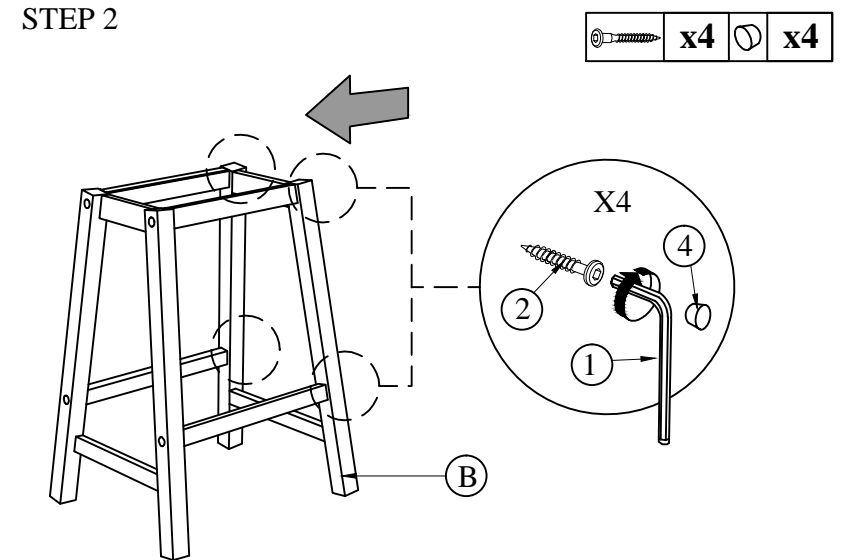
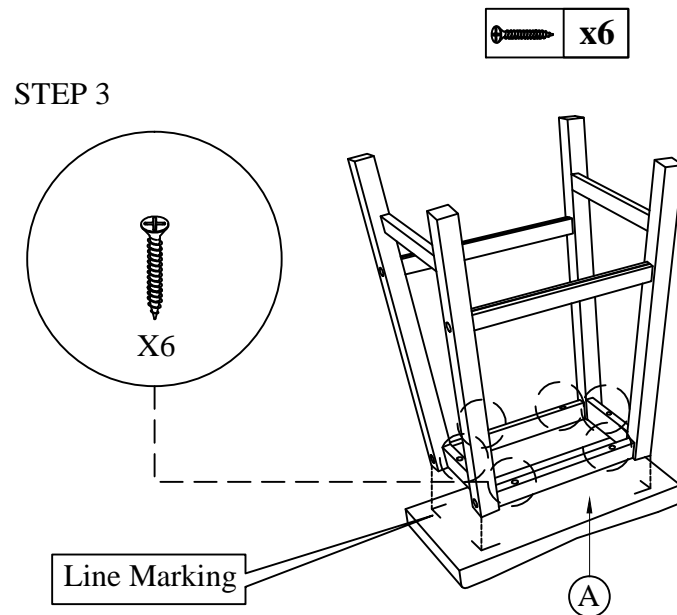
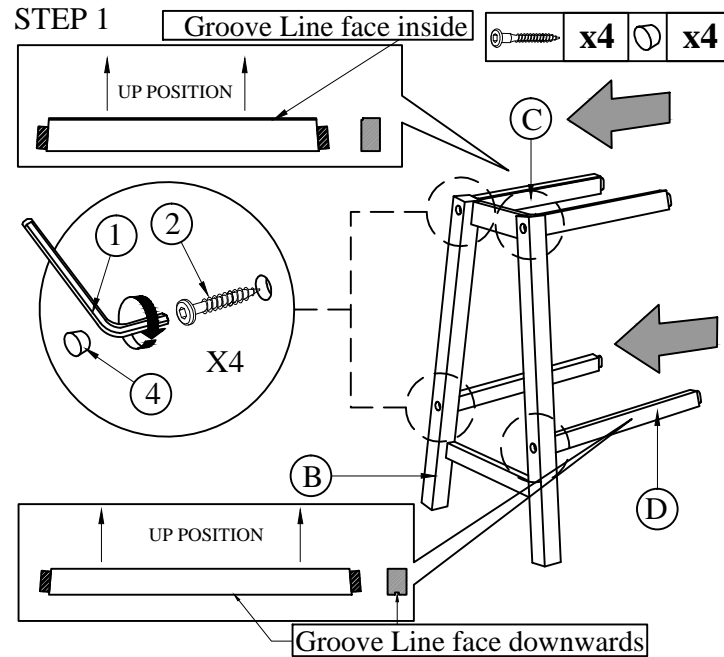

COMPLETE ASSEMBLY

NOTE : MUST TIGHTEN SCREWS PERIODCALLY OR SCREWS WILL BECOME LOOSE.CHECK TIGHTNESS OF ALL SCREWS EVERY 6-8 WEEKS.