

Assembly Manual

Single seat

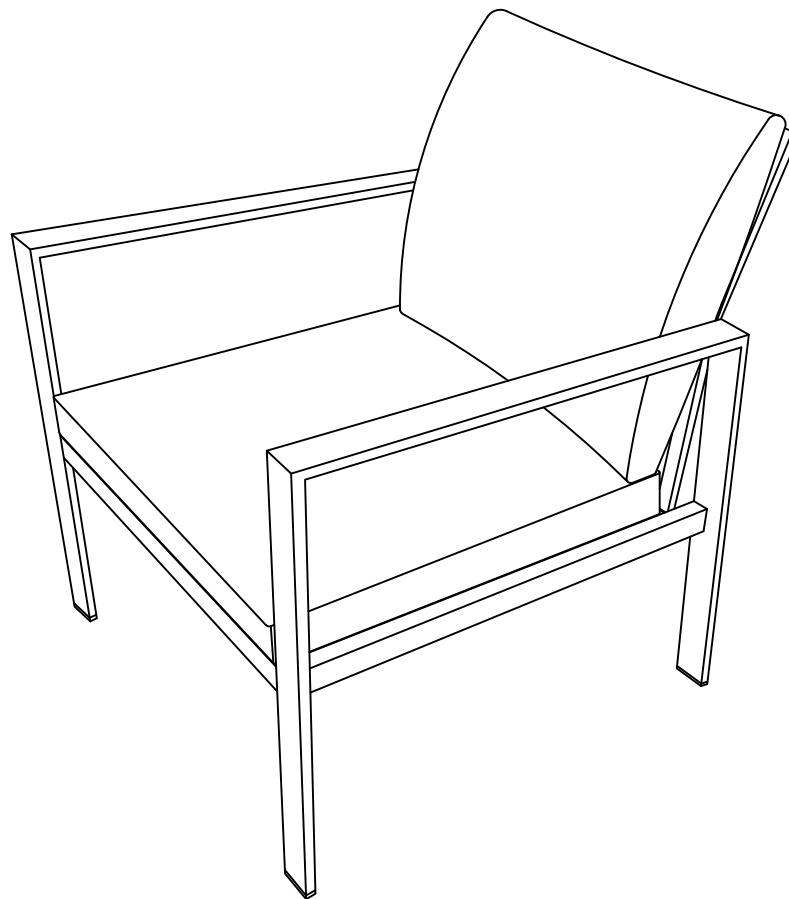

Please read this manual carefully before any operation and keep it properly for future use.
If any problems on our product, please feel free to contact us .

Exploded View

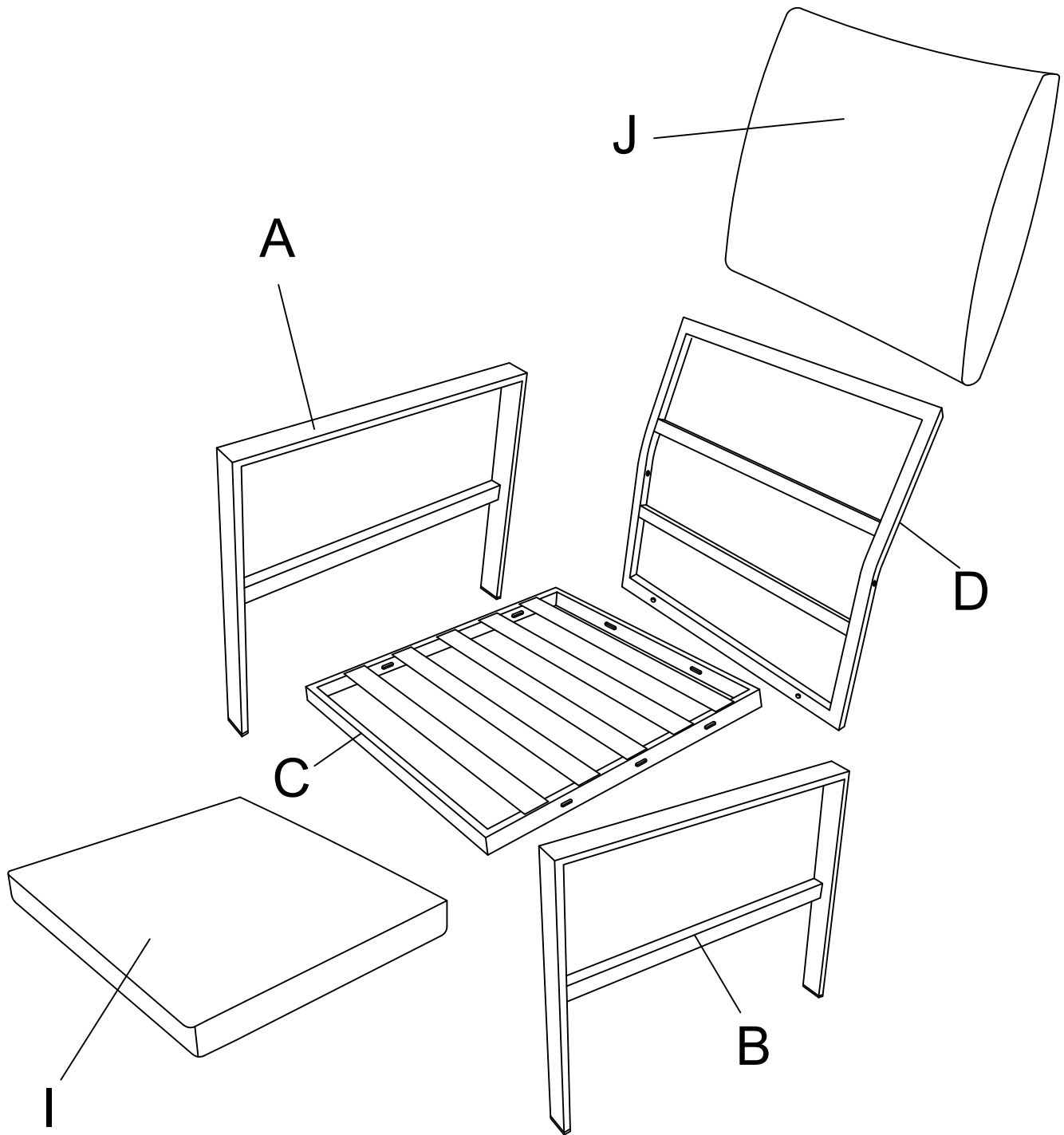

Components List

A

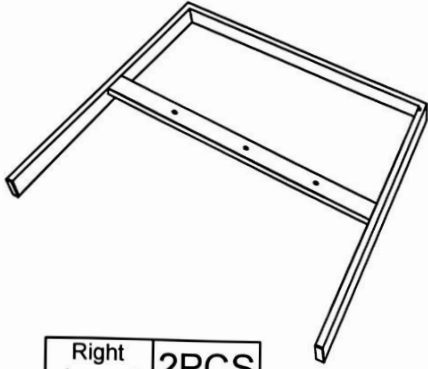

Right Armrest 2PCS

B

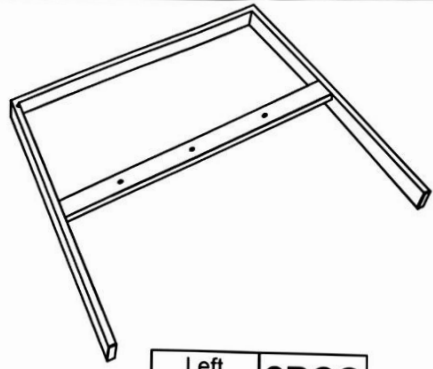

Left Armrest 2PCS

C

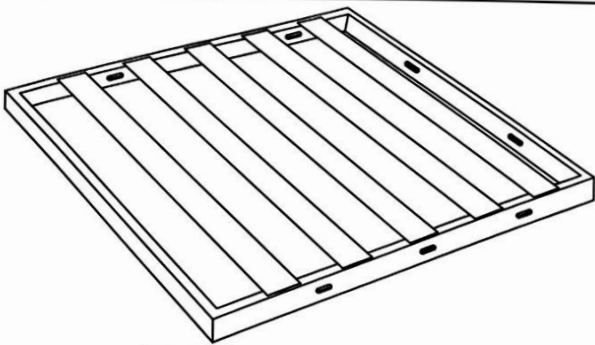

Seat 2PCS

D

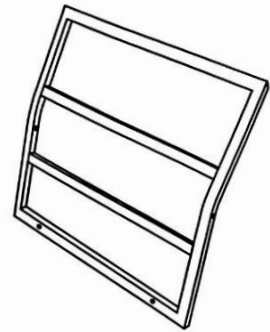

Back 2PCS

E

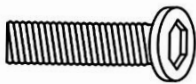

Bolt M6X25 16+2 PCS

F

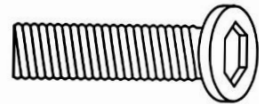

Bolt M6X40 4+1 PCS

G



Washer M6 20+3 PCS

H



Allen wrench M6 1PC

I

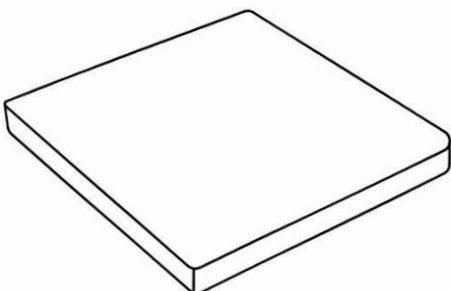

Seat Cushion 2PCS

J

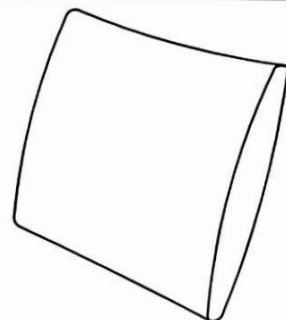

Back Cushion 2PCS

ASSEMBLY INSTRUCTION

Step 1 Attach right armrest(A) to the seat board(C) using washers(G), bolts(E) and Allen wrench(H).
Hand-tighten all screws to about 80% first. After all screws are in place, tighten them fully in sequence

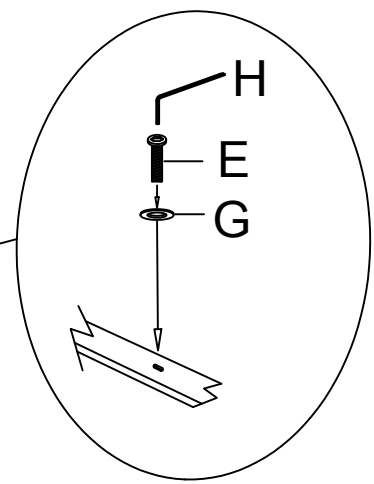
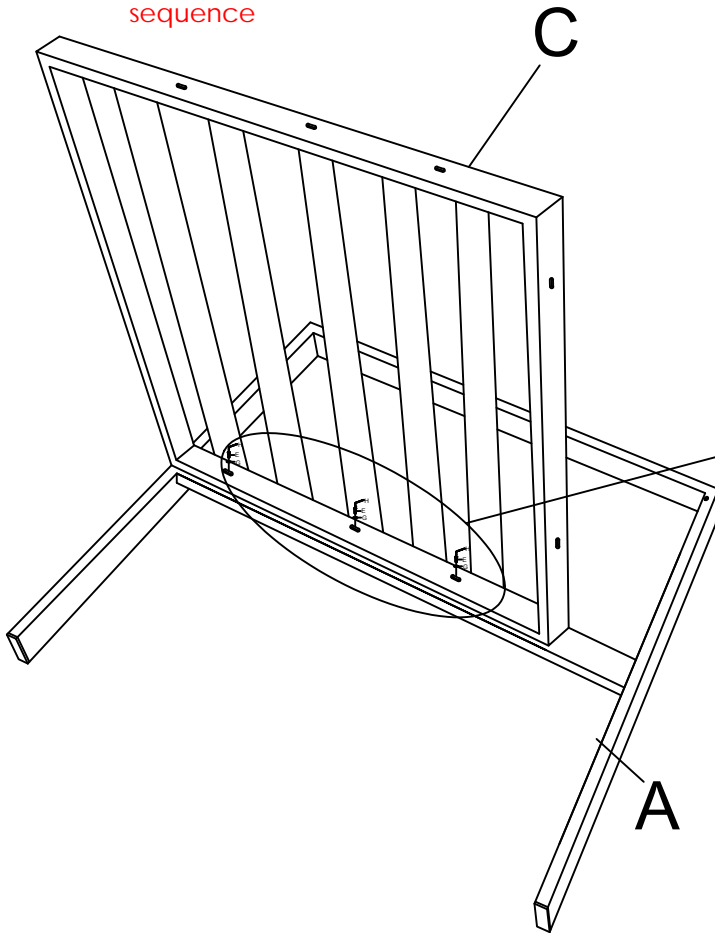

	AX1
	CX1
	EX3
	GX3
	HX1

Step 2 Attach back frame(D) to the seat frame using washers(G), bolts(E&F), and Allen wrench(H).
Hand-tighten all screws to about 80% first. After all screws are in place, tighten them fully in sequence

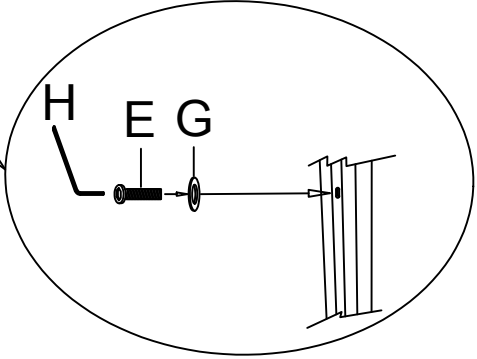
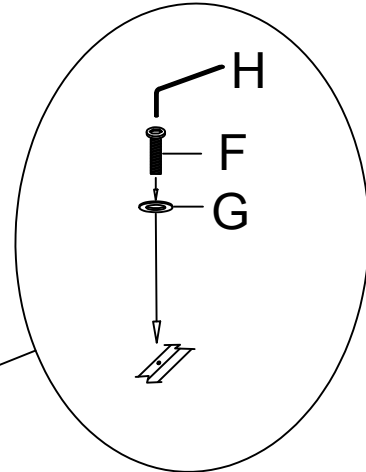
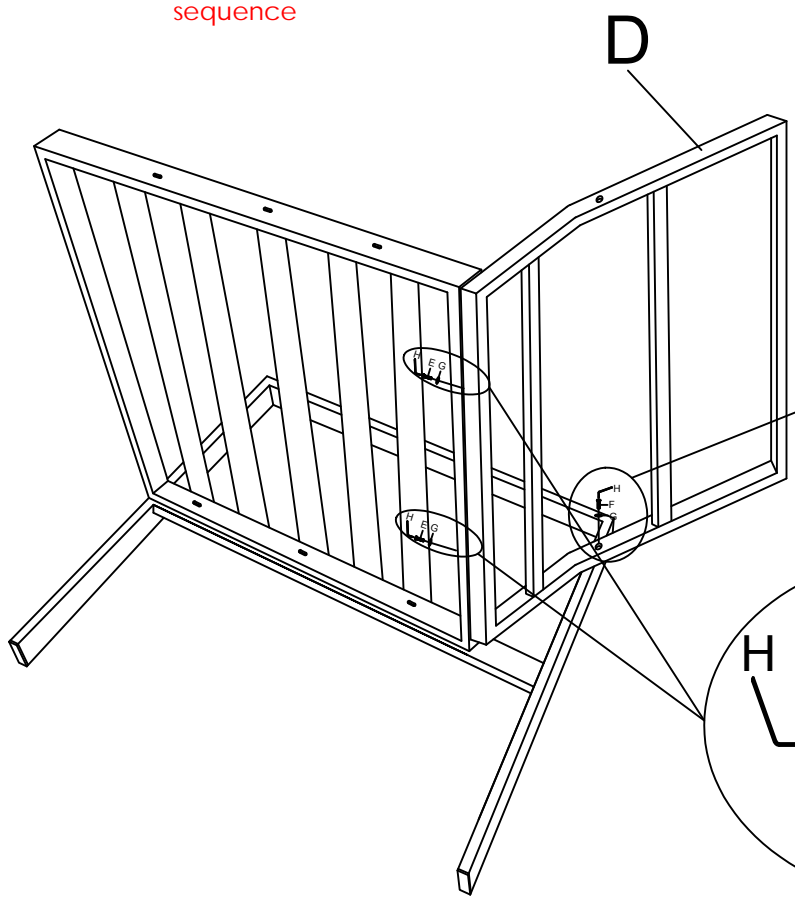





	DX1
	EX2
	FX1
	GX3
	HX1

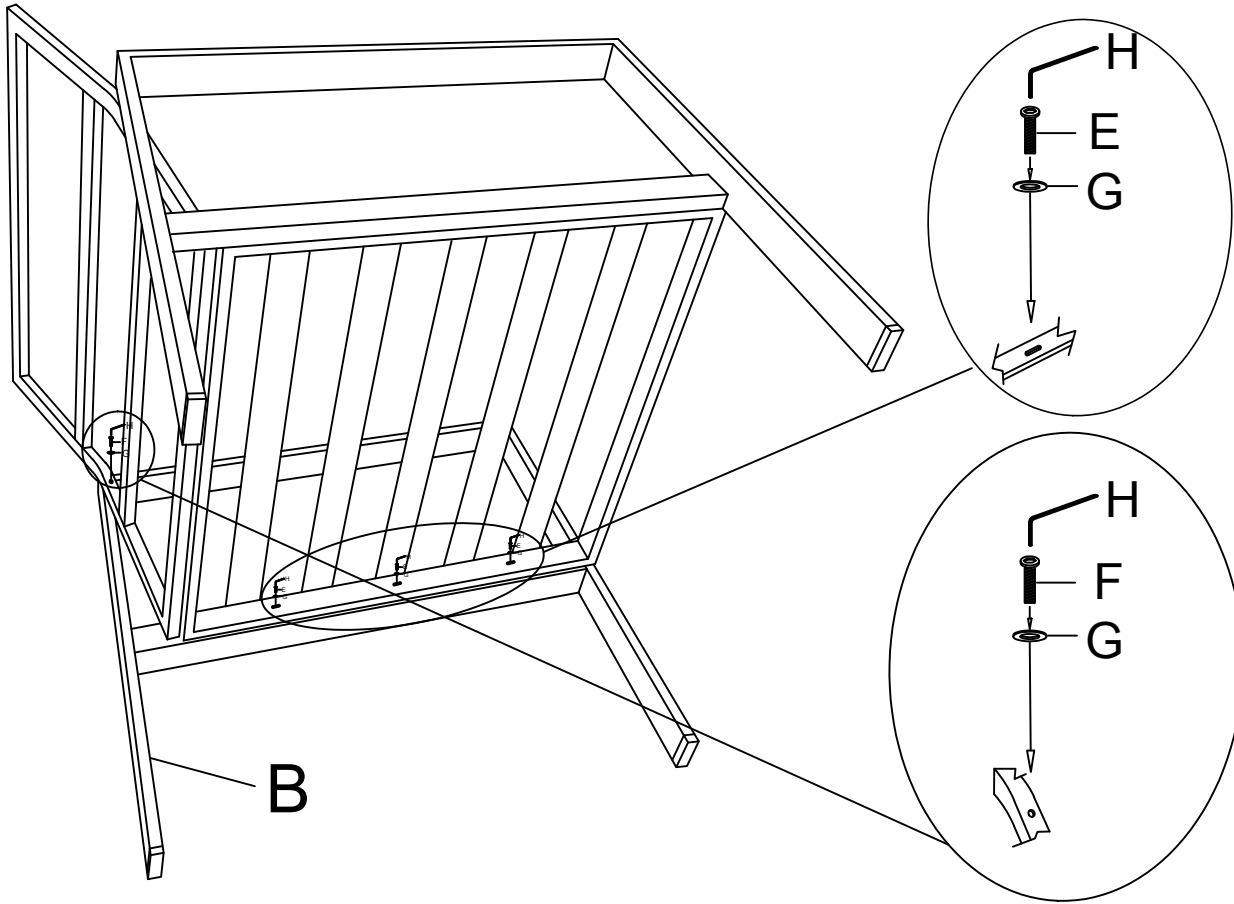

ASSEMBLY INSTRUCTION

Step 3 Attach left armrest(B) to the seat board(C) using washers(G), bolts(E) and Allen wrench(H).
Hand-tighten all screws to about 80% first. After all screws are in place, tighten them fully in sequence

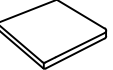

	BX1
	EX3
	FX1
	GX4
	HX1

Step 4 Tighten all bolts 100%, and flip the seat over. Put the seat cushion(I) and back cushion(J) on the seat frame. The assembly is done.

	IX2
	JX2

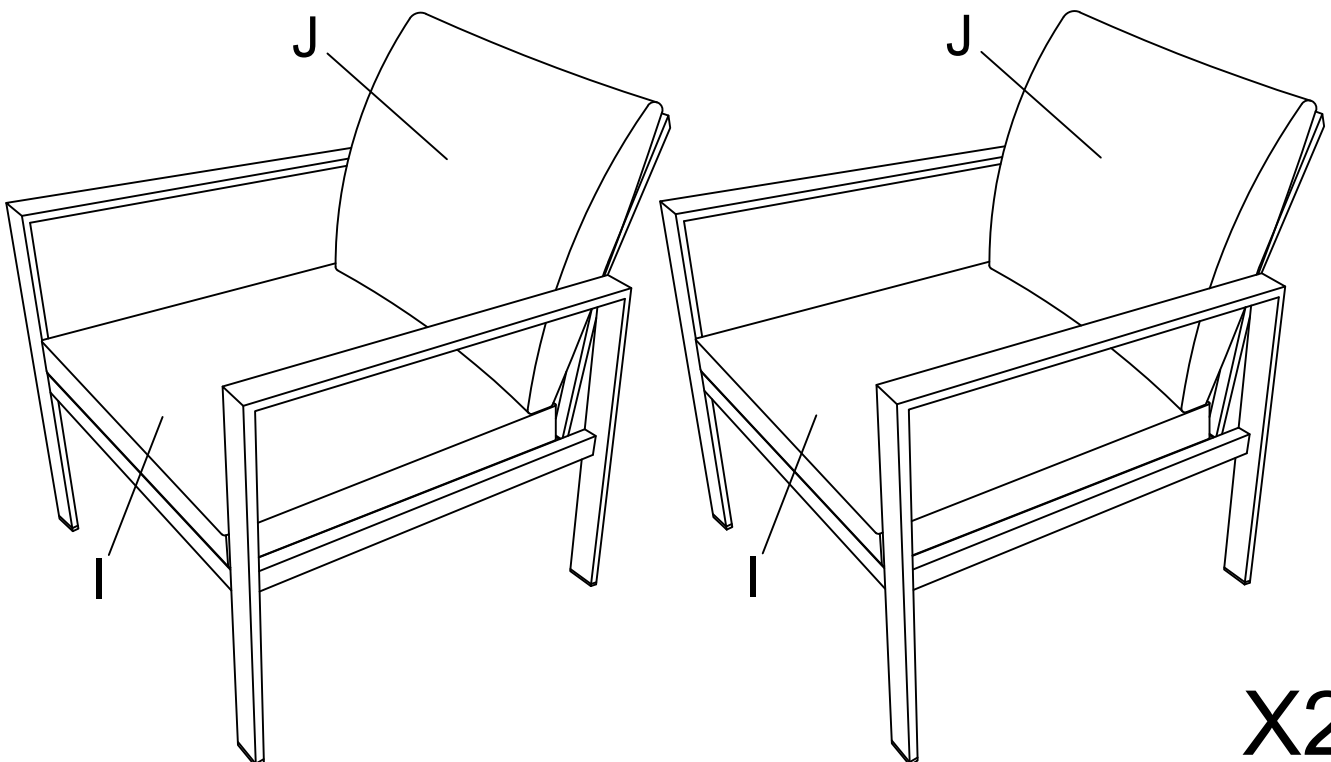

X2