









Read this instruction carefully. See hardware and furniture part list for guidance.
 Be sure all parts are complete, before you assemble. Place all wooden furniture parts on a clean and flat soft surface to prevent from being scratched.
 Follow the figure to start assembling.

CAUTION : 1. Do not FULLY - TIGHTEN the nuts or nuts bolts until they are ready for assembly.
 2. Do not OVER - TIGHTEN the nuts or bolts to avoid causing damages to the thread.
 3. Keep all hardware parts out of reach of children.

NOTE : THE LIST AND QUANTITY SHOWN ARE FOR 1 UNIT ASSEMBLY.

Tools needed : Screwdriver (not provided).

PART LIST			
ITEM	DESCRIPTION	BOX	QTY
A	HEADBOARD	1	1 PC
B	HEADBOARD LEG	1	2 PCS
C	HEADBOARD SUPPORT WOOD	1	2 PCS
D	HEADBOARD SUPPORT RAIL	1	1 PC
E	FOOTBOARD	2	1 PC
F	SIDE RAIL	2	2 PCS
G	CENTER RAIL	2	1 PC
H	CENTER SUPPORT LEG	2	3 PCS
I	BED SLAT	3	1 SET
J	BED LEG	2	4 PCS

HARDWARE LIST (BOX : 2)			
ITEM	DESCRIPTION		QTY
1	JCBC BOLT M6 x 35mm		8 PCS
2	JCBB BOLT M8 x 50mm		6 PCS
3	JCBB BOLT M8 x 60mm		4 PCS
4	M8 FLAT WASHER		10 PCS
5	M8 SPRING WASHER		10 PCS
6	WOOD SCREW M4 x 38mm		9 PCS
7	WOOD SCREW M4 x 20mm		2 PCS
8	M4 ALLEN KEY (BALL SHAPE)		1 PC
9	M5 ALLEN KEY (BALL SHAPE)		1 PC

STEP 1

Take out HEADBOARD LEG (B) , HEADBOARD SUPPORT WOOD (C) & HEADBOARD SUPPORT RAIL (D) from the HEADBOARD BACK (A).

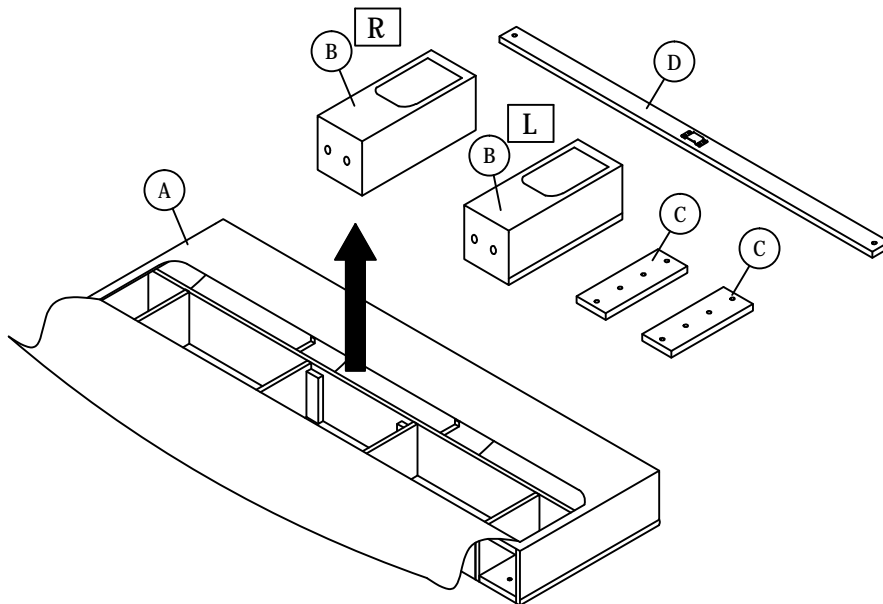

STEP 2

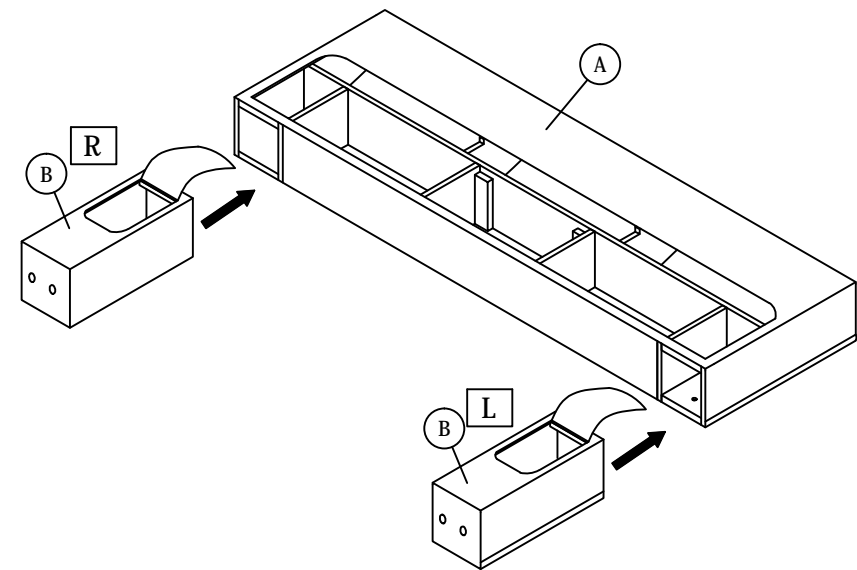

ASSEMBLY INSTRUCTIONS

STEP 3

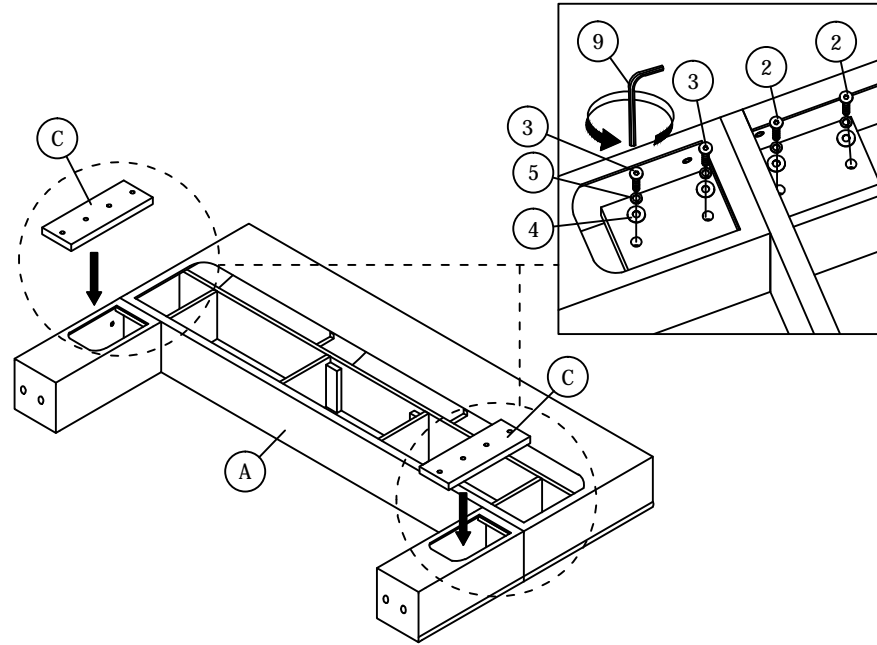

STEP 4

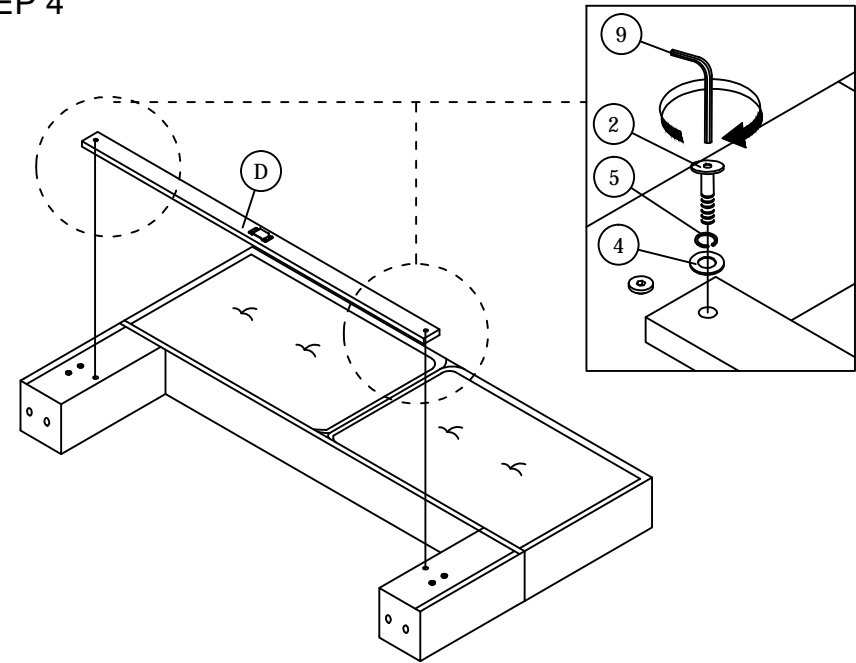

STEP 5

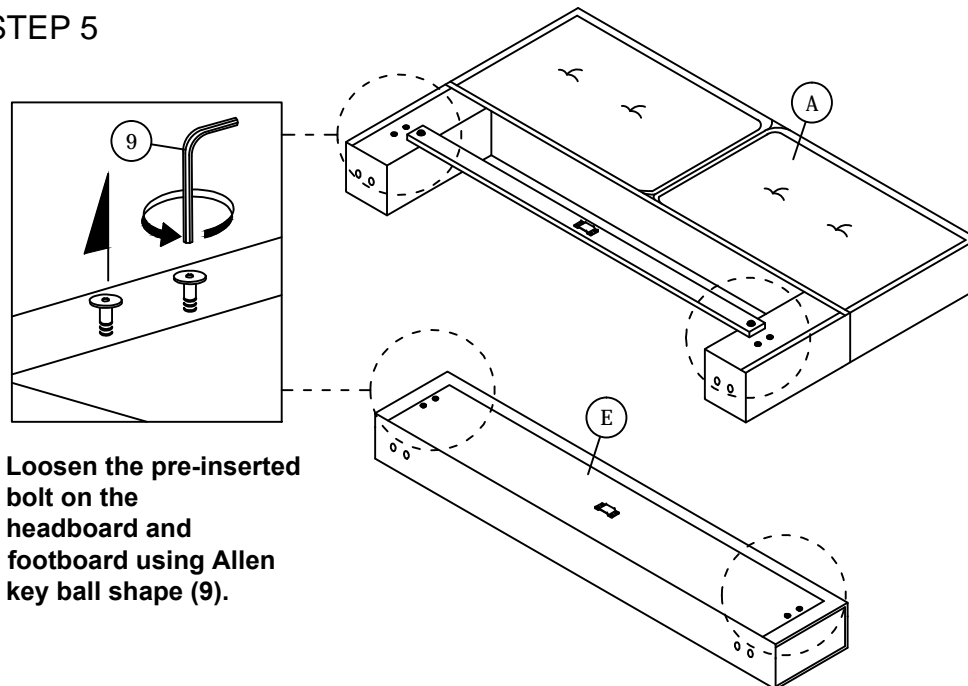

STEP 6

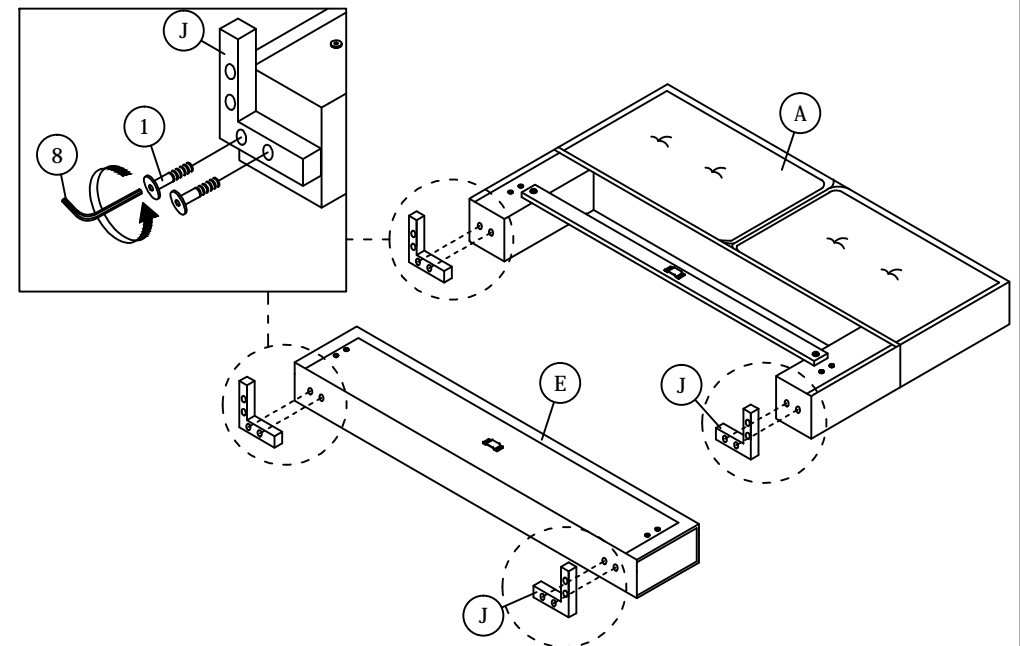

ASSEMBLY INSTRUCTIONS

STEP 7

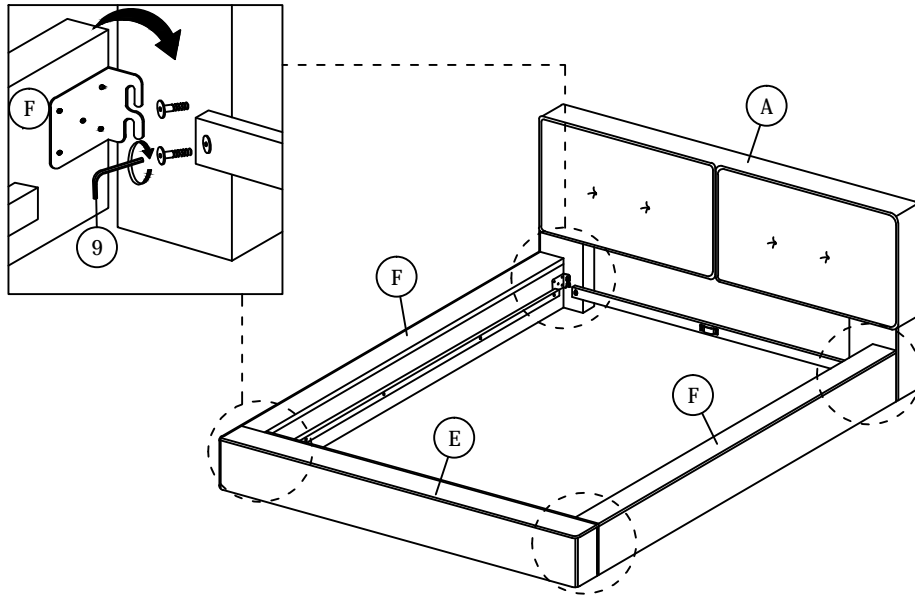

STEP 8

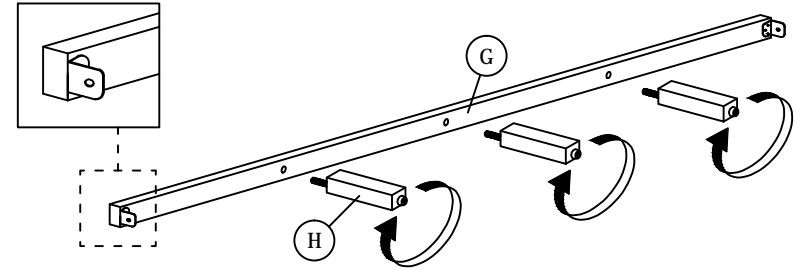

STEP 9

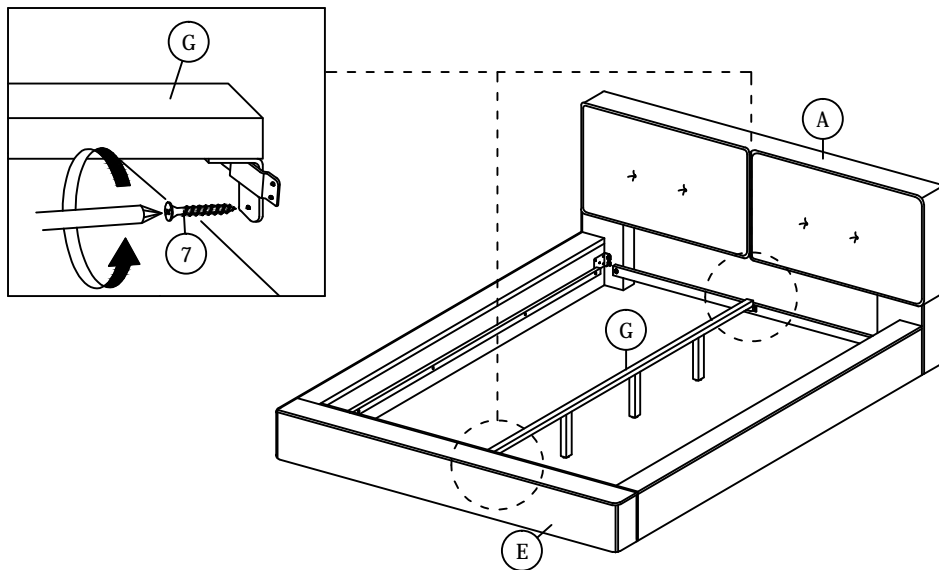

STEP 10

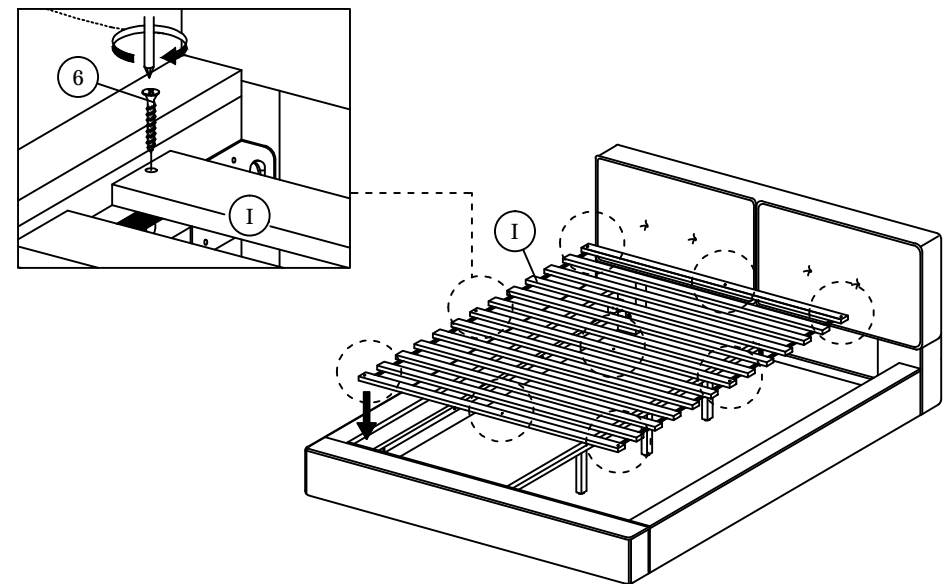

STEP 11

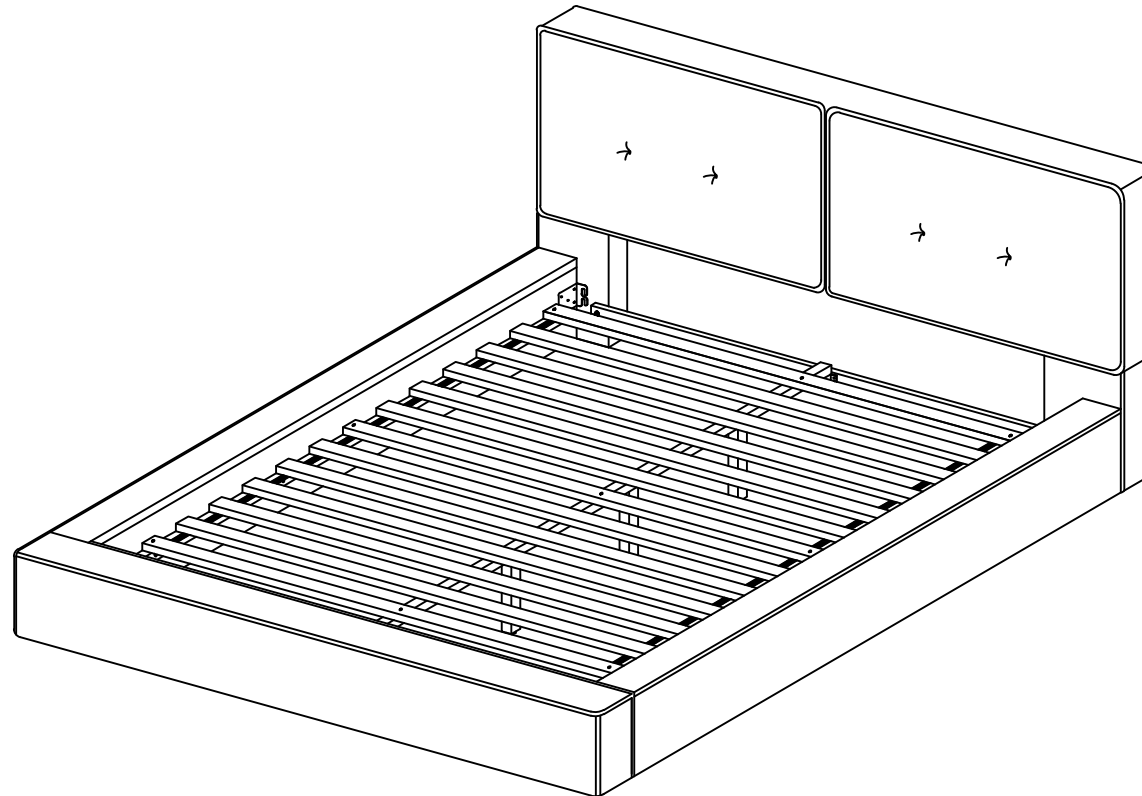

* When moving the bed position, the center support legs must be adjusted or straightened to avoid any broken problems.