

Assembly Instructions

⚠ Before you throw the carton, please ensure that you have all the parts needed for the assembly.

⚠ **Hardware Note:**

1. For each step please don't fully tighten all the screws at first, when they all align to the holes you can fully tighten them.

2. All the bolts should be assembled **vertically** to the holes.

⚠ **Spare parts** can be found in the hardware box if you do not have enough bolts for assembly.

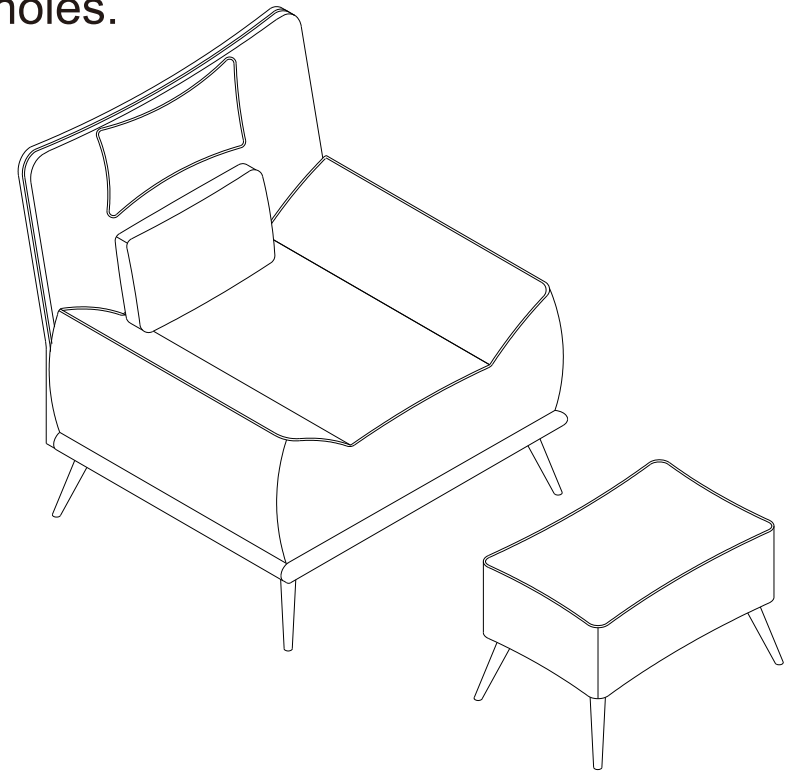

Assembly Instructions

MADE IN CHINA

Parts and Hardware

Please check to make sure you have all parts and hardware before starting assembly process

A

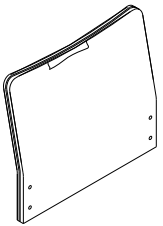

Back 1pc

B

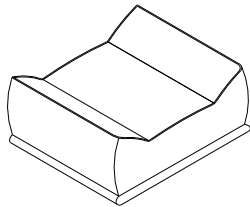

Seat 1pc

C

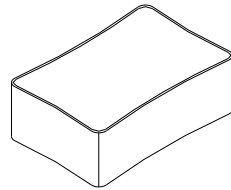

Ottoman 1pc

D

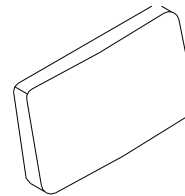

Lower pillow 1pc

E

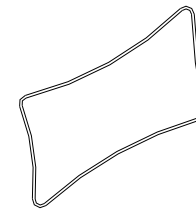

Upper pillow 1pc

F

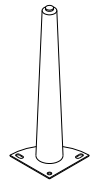

Legs 8pcs

1

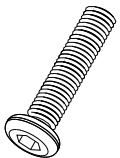

Large bolts
4pcs

2

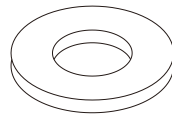

Flat washer
4pcs

3

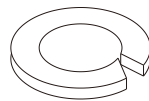

Spring washer
4pcs

4



12pcs assembled on part B
12pcs assembled on part C

Small bolts
24pcs

5



Wrench
1pc

Assembly Instructions

MADE IN CHINA

Assembly Instructions

Step 1: Take out 8 legs out from the bottom of seat.

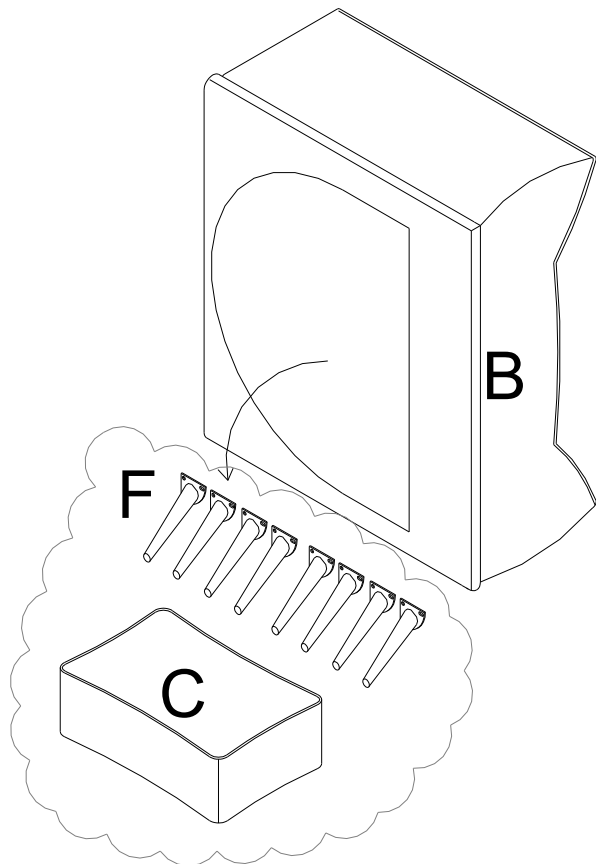

Step 2: Remove 24pcs bolts from the bottom of part B and C.
Remove 4 bolts from the bottom of part A

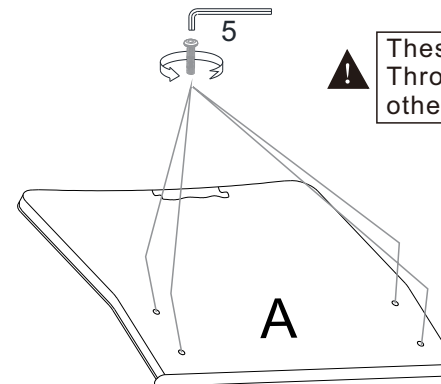
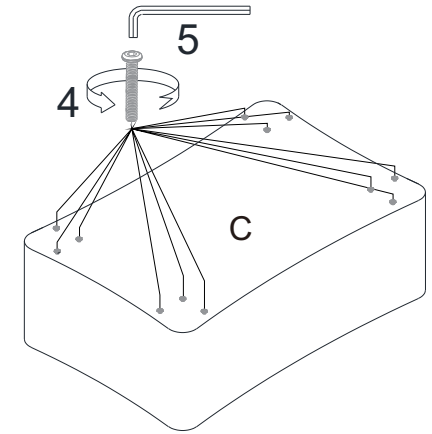
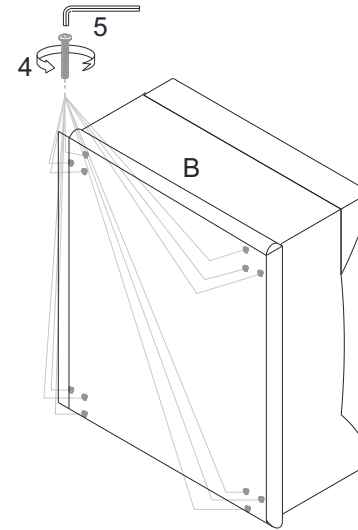

⚠ These bolts are used to protect the holes. You can throw them away or keep them for possible use on other furniture in the future

Assembly Instructions

MADE IN CHINA

Assembly Instructions

Step 3: Assemble back to seat using large bolts, spring washer and flat washer. Do not fully tighten any single bolt until all of them are align to the holes then fully tighten them by the short side of wrench.

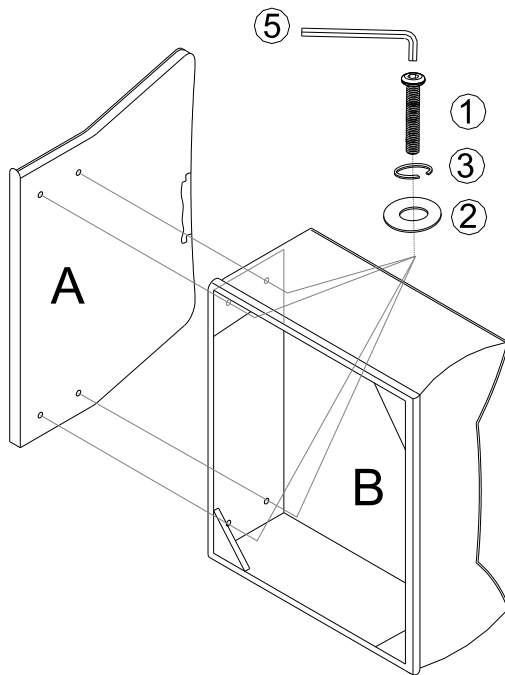

Step 4: Assemble legs to the bottom of seat using small bolt. Half-tighten the bolts one by one until all the bolts are align to the holes then fully tighten them by the short side of wrench.

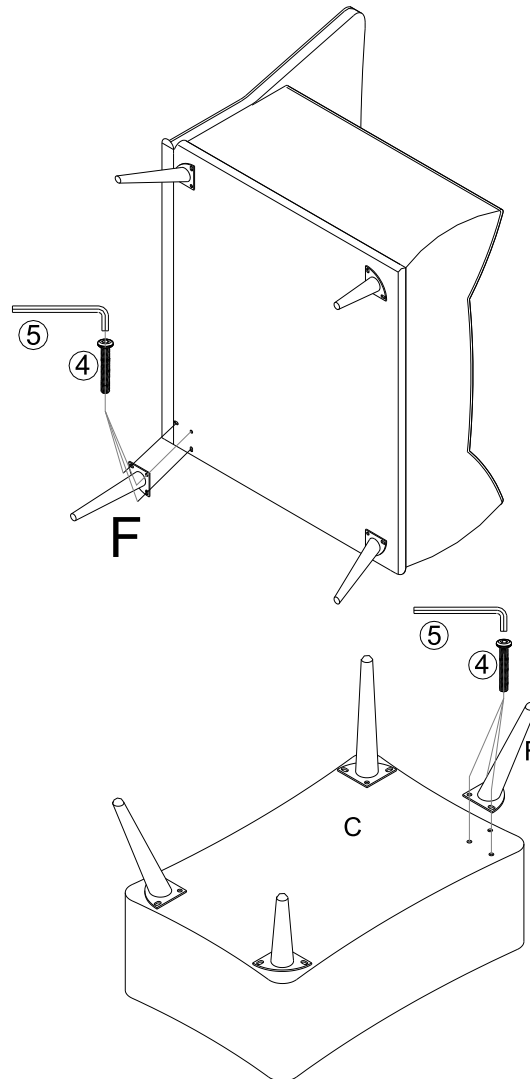

Step 5: Put upper and lower pillow to back.

