

2002517 TUSCANY CABANA
(BAMBOO - CAST PUMICE)

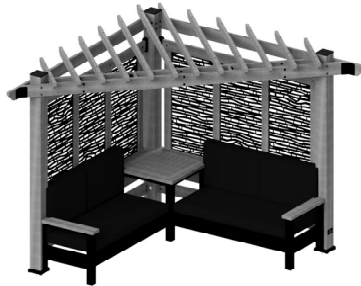

2002524 TUSCANY CABANA
(BAMBOO - SPECTRUM INDIGO)

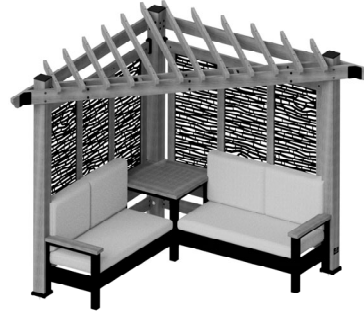

2002531 TUSCANY CABANA
(BAMBOO - CAST SLATE)

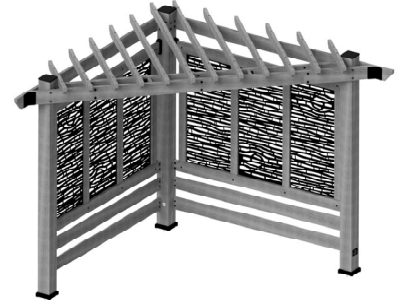

2002548 SIENA CABANA PERGOLA
(BAMBOO PATTERN)

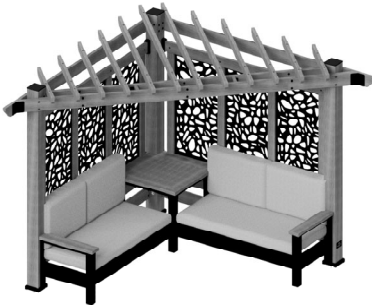

2002555 TUSCANY CABANA
(PEBBLE - CAST PUMICE)

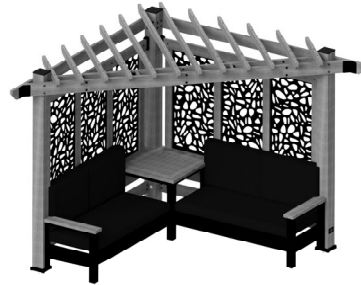

2002562 TUSCANY CABANA
(PEBBLE - SPECTRUM INDIGO)

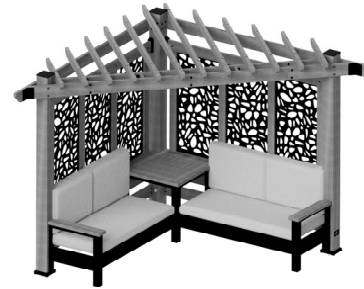

2002579 TUSCANY CABANA
(PEBBLE - CAST SLATE)

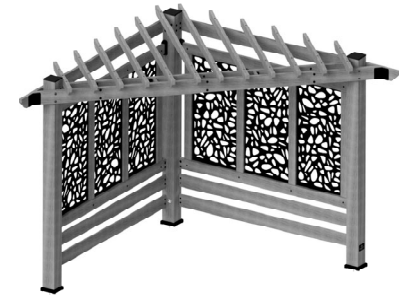

2002586 VERONA CABANA PERGOLA
(PEBBLE PATTERN)

average 2 person assembly time



assembly time may vary based on skill level

Before you begin

FOR QUICK &
EASY ASSEMBLY

FIND 3D INSTRUCTIONS
FOR THIS PRODUCT IN

BILT.

DOWNLOAD THE FREE APP



For the most up to date assembly manual,
to register your set, or to order replacement parts please visit
www.backyarddiscovery.com

**SAVE THIS ASSEMBLY MANUAL FOR FUTURE REFERENCE IN THE EVENT THAT
YOU NEED TO ORDER REPLACEMENT PARTS.**

Para obtener instrucciones en español, visite www.backyarddiscovery.com

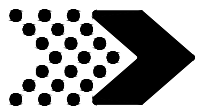

It is critically important that you start with square and level footings, concrete pad or deck to attach your structure





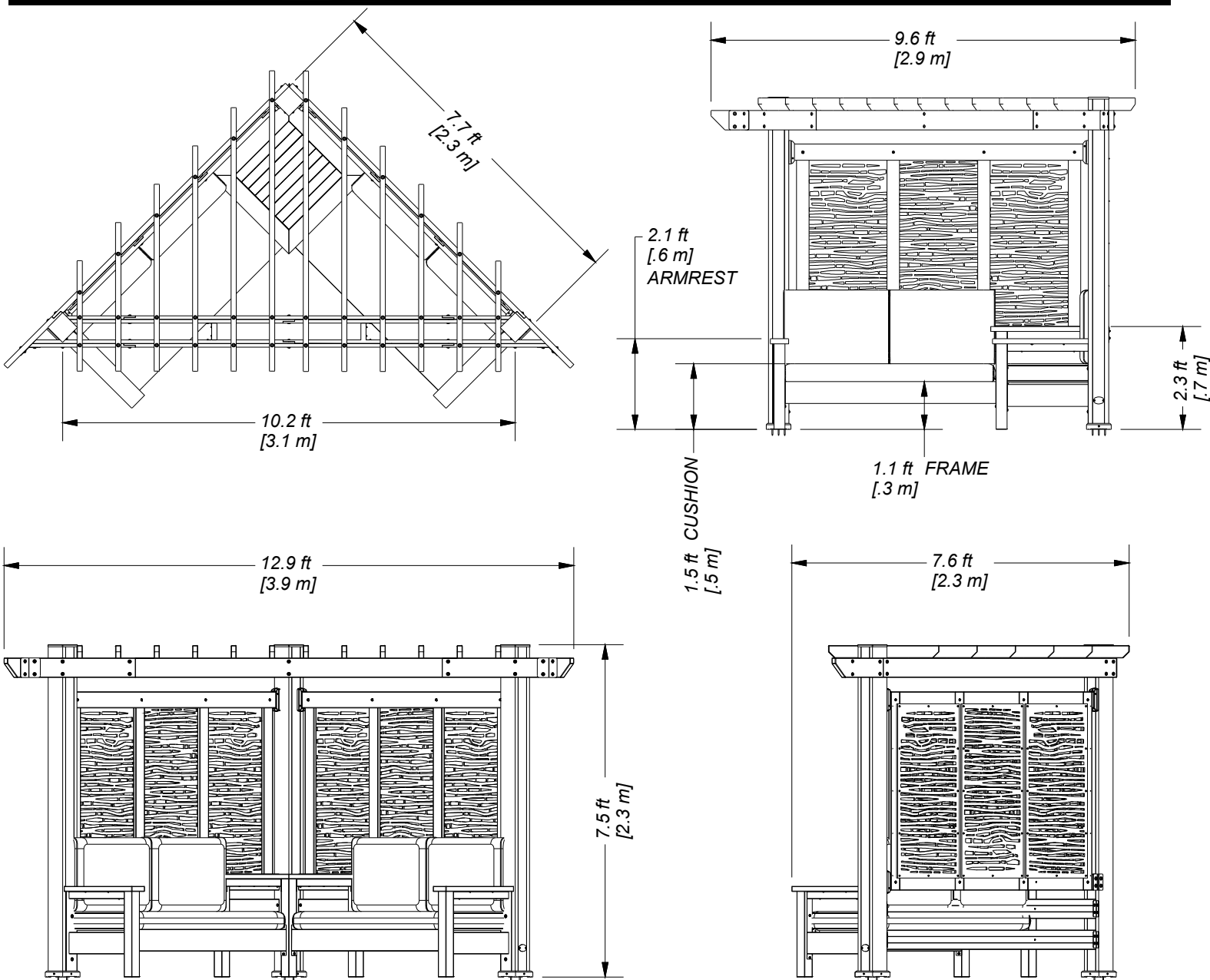

- Pay close attention to the items needed for each step. Make sure you are using the correct hardware for each step. Using incorrect hardware may result in improper assembly
- Remember to double check for underground utilities and overhead electrical lines

Post mounts are provided with your structure which allows you to permanently install your structure to a pre-existing or new wood or concrete surface.

- The hardware to attach the post mounts to the structure is included.
- The hardware to mount the structure permanently to a concrete surface is included.
- The hardware to mount the structure permanently to a wood deck is NOT included and will need to be purchased separately. You must ensure there is ample structural support under the deck before permanently attaching.

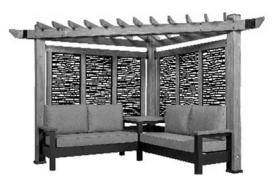

BEFORE YOU BEGIN THE ASSEMBLY OF YOUR BACKYARD DISCOVERY CABANA PERGOLA PLEASE USE THE TABLE BELOW TO ENSURE YOU RECEIVED ALL COMPONENTS NEEDED FOR THE ITEM # YOU PURCHASED. IF YOU ARE MISSING ANY CARTONS PLEASE CONTACT OUR CUSTOMER SERVICE TEAM AT 1-800-856-5424.

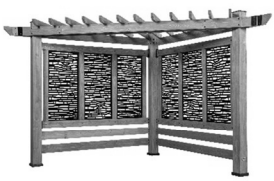
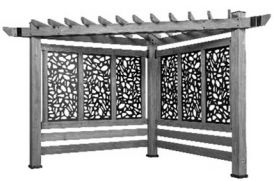
ITEM # ORDERED	NAME	IMAGE	COMPONENT LIST FOR FG	TOTAL # OF CARTONS
2002517	Tuscany Cabana Lounger		9205376-1 - Cedar frame Box 1 9205376-2 - Cedar frame Box 2 9205017-1 - Steel seating frame Box 1 9205017-2 - Steel seating frame Box 2 9205239 - Meranti table top & armrests 9205352 - Composite Panels - bamboo pattern 9205123 - Cushions (Pumice)	7 total cartons
2002524	Tuscany Cabana Lounger		9205376-1 - Cedar frame Box 1 9205376-2 - Cedar frame Box 2 9205017-1 - Steel seating frame Box 1 9205017-2 - Steel seating frame Box 2 9205239 - Meranti table top & armrests 9205352 - Composite Panels - bamboo pattern 9205116 - Cushions (Blue)	7 total cartons
2002531	Tuscany Cabana Lounger		9205376-1 - Cedar frame Box 1 9205376-2 - Cedar frame Box 2 9205017-1 - Steel seating frame Box 1 9205017-2 - Steel seating frame Box 2 9205239 - Meranti table top & armrests 9205352 - Composite Panels - bamboo pattern 9205109 - Cushions (Gray)	7 total cartons
2002555	Tuscany Cabana Lounger		9205376-1 - Cedar frame Box 1 9205376-2 - Cedar frame Box 2 9205017-1 - Steel seating frame Box 1 9205017-2 - Steel seating frame Box 2 9205239 - Meranti table top & armrests 9205369 - Composite panels - pebble pattern 9205123 - Cushions (Pumice)	7 total cartons
2002562	Tuscany Cabana Lounger		9205376-1 - Cedar frame Box 1 9205376-2 - Cedar frame Box 2 9205017-1 - Steel seating frame Box 1 9205017-2 - Steel seating frame Box 2 9205239 - Meranti table top & armrests 9205369 - Composite panels - pebble pattern 9205116 - Cushions (Blue)	7 total cartons
2002579	Tuscany Cabana Lounger		9205376-1 - Cedar frame Box 1 9205376-2 - Cedar frame Box 2 9205017-1 - Steel seating frame Box 1 9205017-2 - Steel seating frame Box 2 9205239 - Meranti table top & armrests 9205369 - Composite panels - pebble pattern 9205109 - Cushions (Gray)	7 total cartons
2002548	Verona Cabana Pergola		9205376-1 - Cedar frame Box 1 9205376-2 - Cedar frame Box 2 9205352 - Composite Panels - bamboo pattern	3 total cartons
2002586	Verona Cabana Pergola		9205376-1 - Cedar frame Box 1 9205376-2 - Cedar frame Box 2 9205369 - Composite panels - pebble pattern	3 total cartons



Wood Components (Not to Scale)

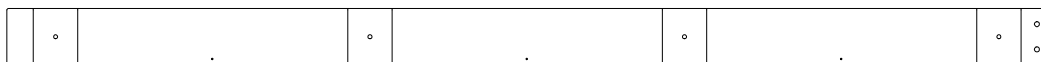

AN1 | LOWER SUPPORT - W4L13810
(1) | 1 3/8"x4 3/8"x81 1/4" (36x112x2064)

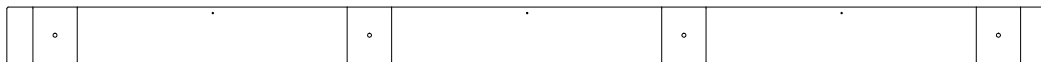

AN2 | TOP SUPPORT - W4L13809
(2) | 1 3/8"x4 3/8"x81 1/4" (36x112x2064)

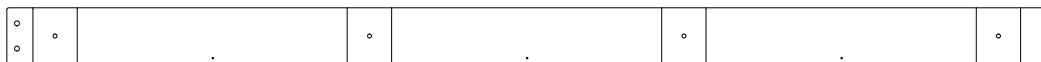

AN3 | LOWER SUPPORT - W4L13835
(1) | 1 3/8"x4 3/8"x81 1/4" (36x112x2064)



D1 | JOIST - W4L13812
(1) | 1 3/8"x5 1/4"x89 1/2" (36x134x2274)



D2 | JOIST - W4L13813
(1) | 1 3/8"x5 1/4"x89 1/2" (36x134x2274)



D3 | JOIST END - W4L13814
(1) | 1 3/8"x5 1/4"x18 3/4" (36x134x477)



D4 | JOIST END - W4L13815
(1) | 1 3/8"x5 1/4"x18 3/4" (36x134x477)



D5 | SUPPORT BRACE - W4L13823
(2) | 1 3/8"x5 1/4"x4 5/8" (36x134x116)



E1 | TOP JOIST - W4L13824
(2) | 1 3/8"x3 3/8"x81 1/2" (36x86x2070)



E2 | TOP JOIST - W4L13825
(2) | 1 3/8"x3 3/8"x71 1/2" (36x86x1817)



E3 | TOP JOIST - W4L13826
(2) | 1 3/8"x3 3/8"x61 1/8" (36x86x1553)



E4 | TOP JOIST - W4L13827
(2) | 1 3/8"x3 3/8"x50 3/4" (36x86x1289)



E5 | TOP JOIST - W4L13828
(2) | 1 3/8"x3 3/8"x40 3/8" (36x86x1025)



E6 | TOP JOIST - W4L13829
(2) | 1 3/8"x3 3/8"x30" (36x86x761)



Wood Components (Not to Scale)

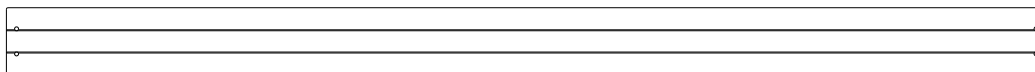

G3 | TOP RAIL - W4L13832
(4) | 1"x5 1/4"x81 1/4" (24x134x2063)



G7 | BEAM END - W4L13816
(1) | 1"x5 1/4"x29" (24x134x736)



G8 | BEAM - W4L13817
(2) | 1"x5 1/4"x89 1/2" (24x134x2274)



G9 | BEAM - W4L13818
(1) | 1"x5 1/4"x71 1/8" (24x134x1807)



G10 | BEAM - W4L13819
(1) | 1"x5 1/4"x71 1/8" (24x134x1807)



G11 | BEAM END - W4L13820
(1) | 1"x5 1/4"x19" (24x134x484)



G12 | BEAM - W4L13821
(1) | 1"x5 1/4"x61 1/4" (24x134x1555)



G13 | BEAM - W4L13822
(1) | 1"x5 1/4"x61 1/4" (24x134x1555)



Wood Components (Not to Scale)



G14 | BEAM END - W4L13830
(1) | 1"x5 1/4"x29" (24x134x736)



G15 | BEAM END - W4L13831
(1) | 1"x5 1/4"x19" (24x134x484)



H1 | VERTICAL SUPPORT - W4L13808
(8) | 1"x3 3/8"x53 7/8" (24x86x1368)



WP1 | W2A02859
(1) | 5 1/2"x5 1/2"x89 5/8" (140x140x2274)



WP2 | W2A02860
(1) | 5 1/2"x5 1/2"x89 5/8" (140x140x2274)



WP3 | W2A02861
(1) | 5 1/2"x5 1/2"x89 5/8" (140x140x2274)

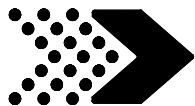

Wood Components (Not to Scale)

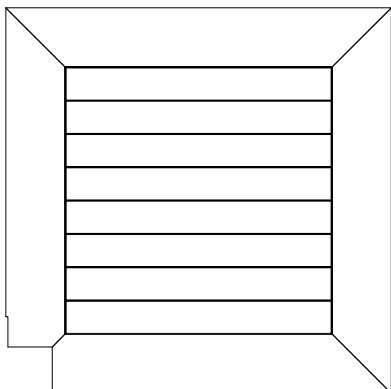

TT1 | W2A02868
(1) | 1 5/16"x30 1/8"x30 1/8" (34x765x765)

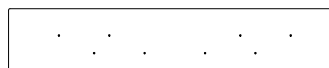

D7 | ARM REST - W4L14844
(2) | 1 3/8"x4 5/8"x26" (34x118x660)



Hardware Components



H100363 | BOLT WH BLK
(18) | 5/16X6



H100407 | BOLT WH BLK
(18) | 5/16x1 1/2



H100468 | BOLT WH BLK
(4) | 5/16x1



H100193 | NUT BARREL
(18) | WH BLK
5/16x1-1/2



H100825 | LAG SCREW
(38) | 5/16x4 BLK



H100192 | NUT BARREL
(18) | WH BLK
5/16x7/8



H100206 | LAG SCREW WH BLK
(4) | 5/16x3

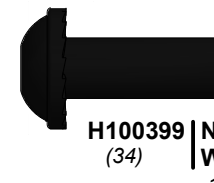

H100399 | NUT BARREL
(34) | WH BLK
1/4x7/8



H100197 | LAG SCREW WH BLK
(4) | 5/16x2 1/2



H100379 | T-NUT BLK
(4) | 5/16



H100471 | LAG SCREW WH BLK
(9) | 5/16x1 1/2



H100403 | LAG SCREW WH BLK
(18) | 1/4x1 1/2

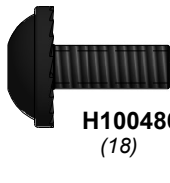

H100486 | BOLT WH BLK
(18) | 1/4x5/8

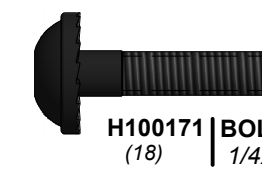

H100171 | BOLT WH BLK
(18) | 1/4x1



Hardware Components



H100391 | SCREW PFH BLK
(13) | 8x2



H100200 | SCREW PFH BLK
(13) | 8x1 1/2



H100385 | SCREW PFH BLK
(13) | 8x1



H100120 | SCREW
CONCRETE
ANCHOR
(13) | 1/4x2



H100797 | SCREW PWH BLK
(76) | 8x1



H100392 | SCREW PWH BLK
(2) | 8x3/4



H100202 | SCREW PWH BLK
(17) | 8x5/8



H100199 | WASHER LOCK
(35) | EXT BLK
12x19



H100400 | WASHER LOCK
(35) | EXT BLK
8x15



H100405 | WASHER LOCK
(17) | EXT BLK
6x15



H100198 | WASHER LOCK
(76) | EXT BLK
8x19



H100764 | SCREW SETTER
(1)

9220119 | TOOL KIT
(1)

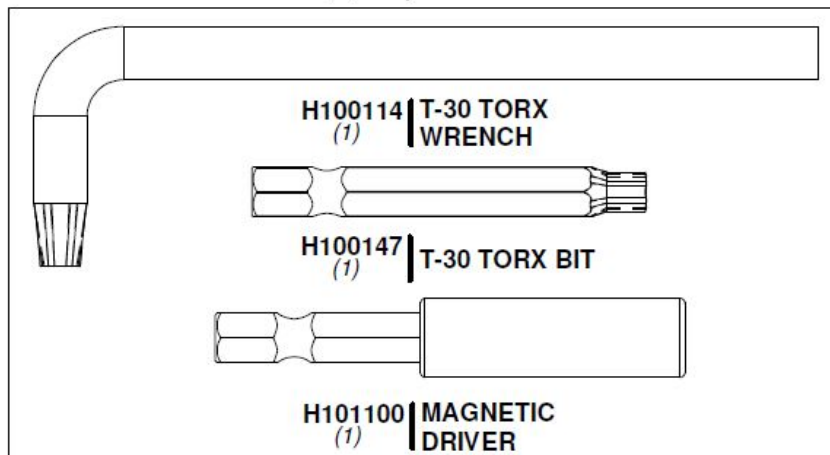

H100114 | T-30 TORX
(1) | WRENCH

H100147 | T-30 TORX BIT
(1)

H101100 | MAGNETIC
(1) | DRIVER

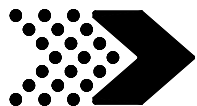

Accessory Components (Not to Scale)

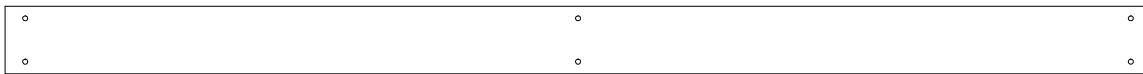

A4M01111 | METAL BEAM
(2)

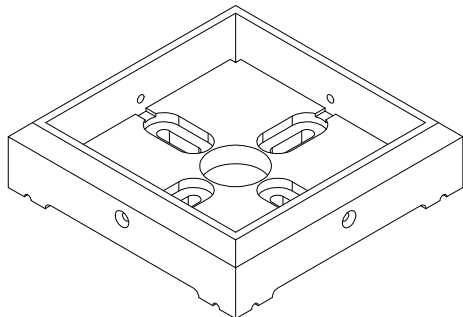

A100029 | FOOT 142
(3) | SQUARE POST



A100241 | BYD ID TAG
(1) | (SMALL)
WITHOUT AGES

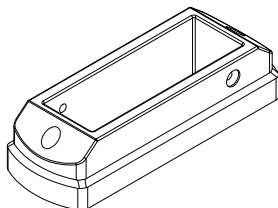

A6P00442 | MOUNTING
(6) | BRACKET

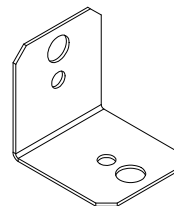

A4M00555 | 90° L-BRACKET -
(8) | BLK

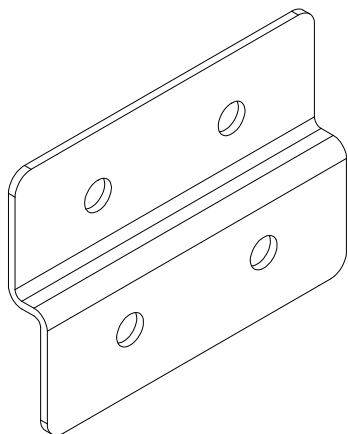

A4M01166 | L BRACKET
(2) | 40x40x112 - BLK

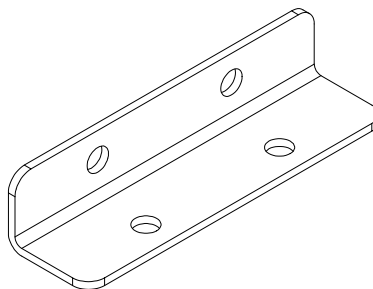

A4M01108 | L BRACKET
(8) | 24x30x112 - BLK

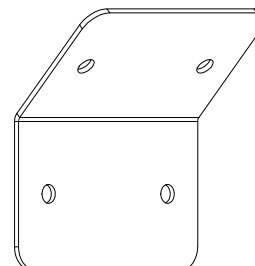

A4M01097 | BRACKET 135°
(2) | BLK

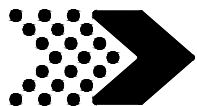

Accessory Components (Not to Scale)

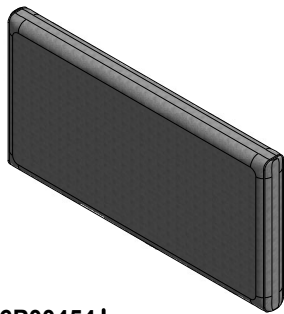

A6P00454
(2) SEAT CUSHION

9205123
CAST PUMICE

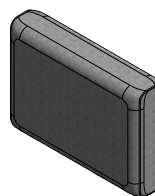

A6P00455
(4) BACK CUSHION

OR

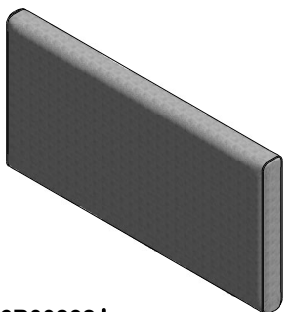

A6P00392
(2) SEAT CUSHION

9205109
CAST SLATE

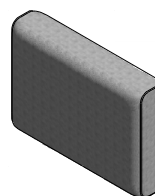

A6P00393
(4) BACK CUSHION

OR



A6P00394
(2) SEAT CUSHION

9205116
SPECTRUM INDIGO



A6P00395
(4) BACK CUSHION

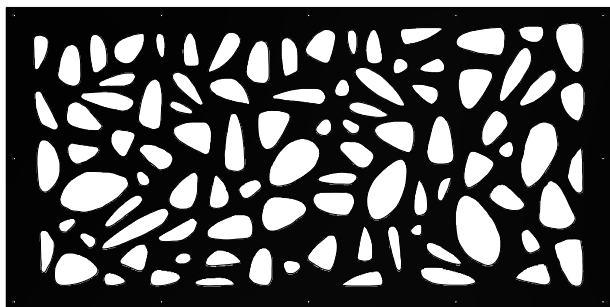

A6P00441
(6) DECORATIVE BACK PANEL

OR

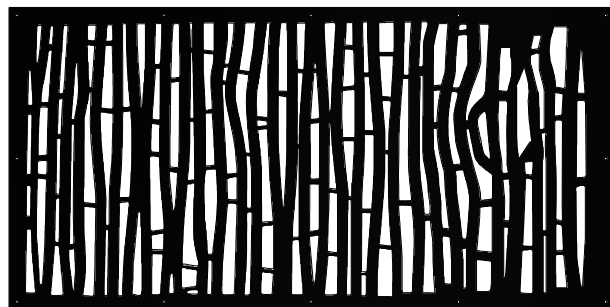

A6P00440
(6) DECORATIVE BACK PANEL

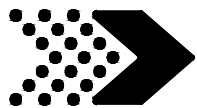

Accessory Components (Not to Scale)

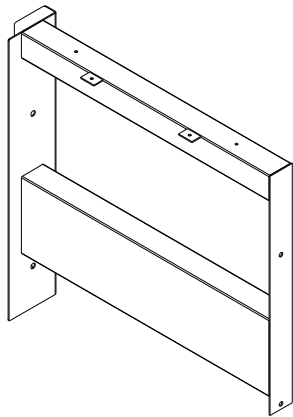

A4M01060 (1) | FRAME END

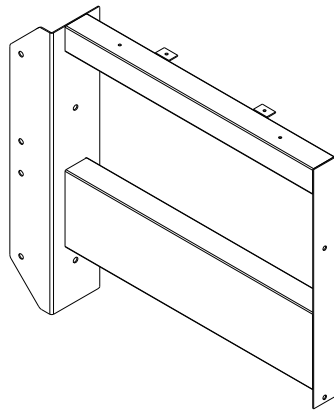

A4M01066 (1) | FRAME END



A4M01063 (1) | POST



A4M01069 (1) | POST



A4M01070 (1) | POST



A4M01105 (1) | ARM POST - LEFT

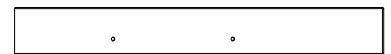

A4M01106 (1) | ARM POST - RIGHT

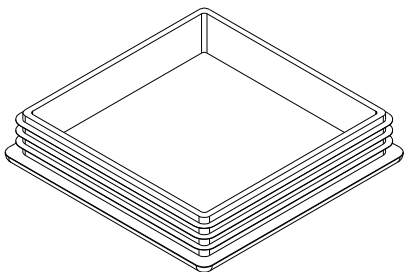

A6P00377 (5) | SNAP-IN SQUARE PLUG

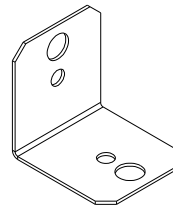

A4M00555 (2) | 90° L-BRACKET - BLK

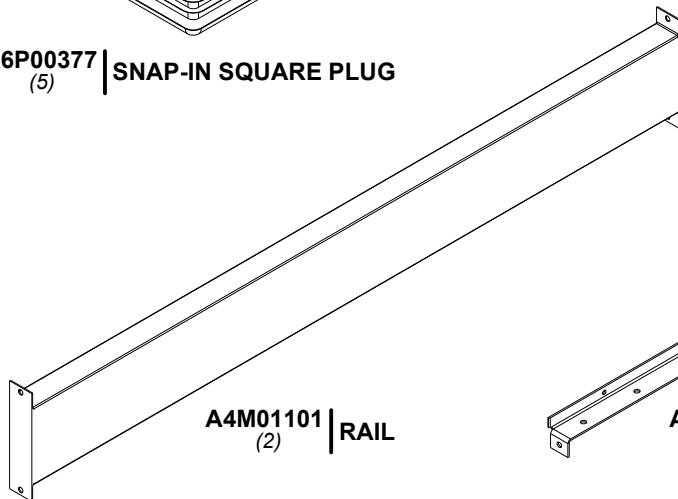

A4M01101 (2) | RAIL

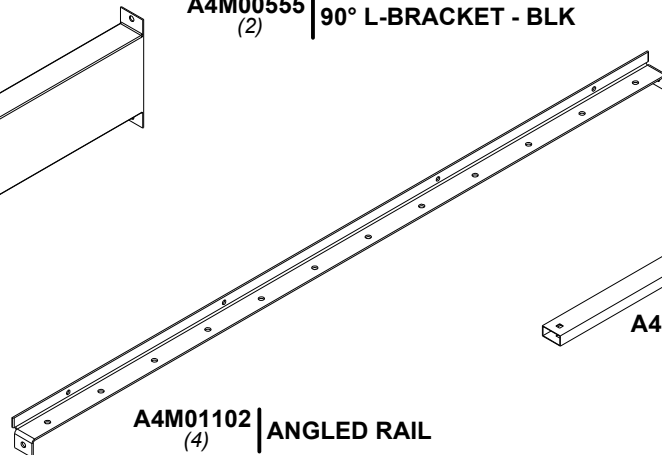

A4M01102 (4) | ANGLED RAIL

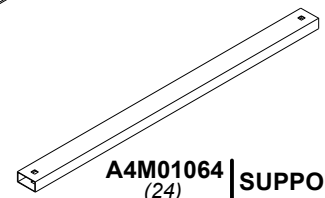

A4M01064 (24) | SUPPORT

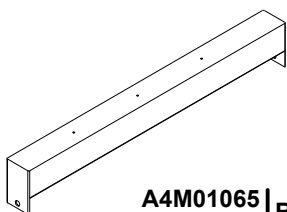

A4M01065 (2) | RAIL

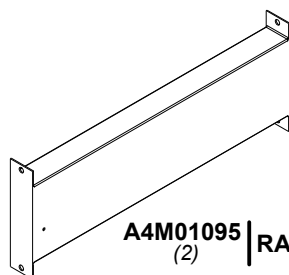

A4M01095 (2) | RAIL

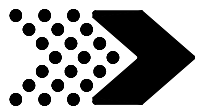

Accessory Components (Not to Scale)



H100471 | LAG SCREW WH BLK
(11) | 5/16x1 1/2



H100171 | BOLT WH BLK
(38) | 1/4x1



H100460 | LAG SCREW WH BLK
(11) | 1/4x1



H100712 | BOLT CARRIAGE BLK
(50) | 5/16x1 1/2



H100824 | SCREW PWH BLK
(11) | 8x3



H100391 | SCREW PFH BLK
(7) | 8x2



H100392 | SCREW PWH BLK
(4) | 8x3/4



H100202 | SCREW PWH BLK
(4) | 8x5/8

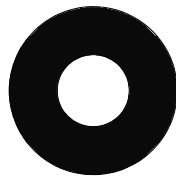

H100770 | WASHER FLAT
(52) | BLK
5/16

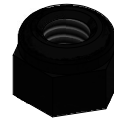

H100479 | NUT LOCK BLK
(50) | 5/16



H100856 | DRILL BIT
(1) | 1/4" (6mm)

PRE-ASSEMBLY STEP 1 - SORTING PARTS

It is critical for ease of assembly that you take the time to sort and organize the wood and hardware.

WOOD PARTS:

- Organize wood parts by the three-digit, alpha-numeric number stamped on each board (ex. P01).
- If there are multiple boards with the same stamped number, stack those pieces together.
- Stamps can be found on the flat surface of the boards or on the end of the boards.
- Allow yourself plenty of room - the wood pieces can take up a significant amount of space.

NOTE: CARTONS ARE NOT ORGANIZED BY BOARD NUMBER.

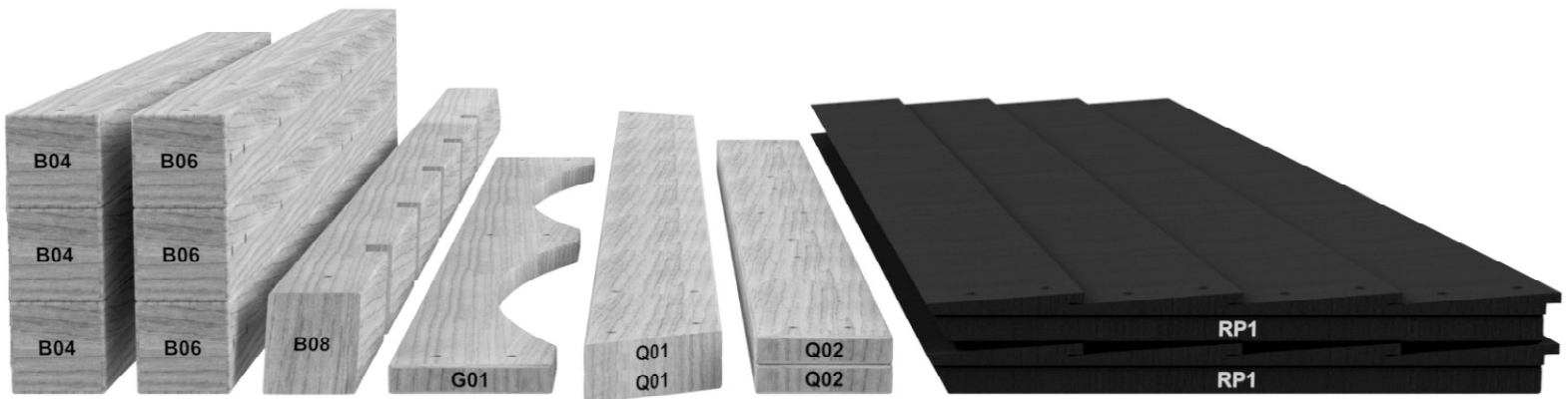

HARDWARE PARTS:

- We recommend that you have a separate table to organize the hardware.
- Hardware bags are printed with a seven-digit, alpha-numeric part number.
- You can organize your hardware by part number or group by hardware type (i.e. bolts, nuts, etc.).
- During assembly you only need to reference the last four digits of the number.

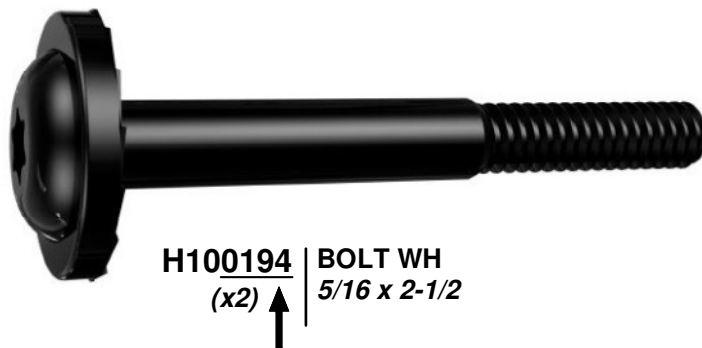

PRE-ASSEMBLY STEP 2 - TOOLS REQUIRED



**Cordless Drill or
Electric Drill**



**Drill Attachments:
Phillips Head**



**1/8", 3/16", 3/8" & 7/16"
Drill Bits**



Phillips Screw Driver



Open End Wrenches 1/2" & 9/16"



**3/8" Drive Ratchet, 1/2" &
9/16" STD Sockets 1/2" & 9/16" Deep
Sockets**



Claw Hammer



Rubber Mallet - Optional



Tape Measure

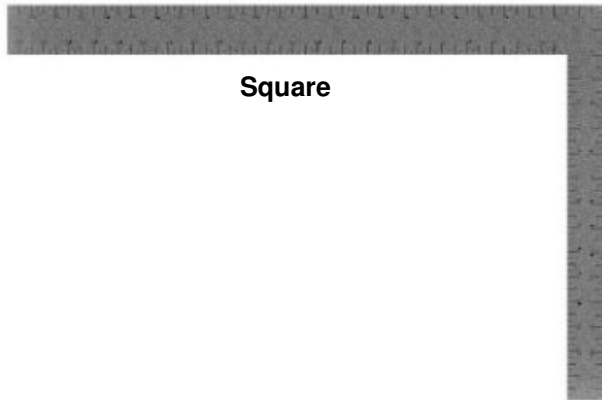

Square



Level 24"

PRE-ASSEMBLY STEP 3 - CHOOSE YOUR ASSEMBLY METHOD

There are several types of assembly instructions available to you.

1. Printed Assembly Manual included with your set
2. BILT APP - 3D interactive instructions
3. Combination of the Printed Manual and BILT APP (Note: Step numbers can differ between the two methods)

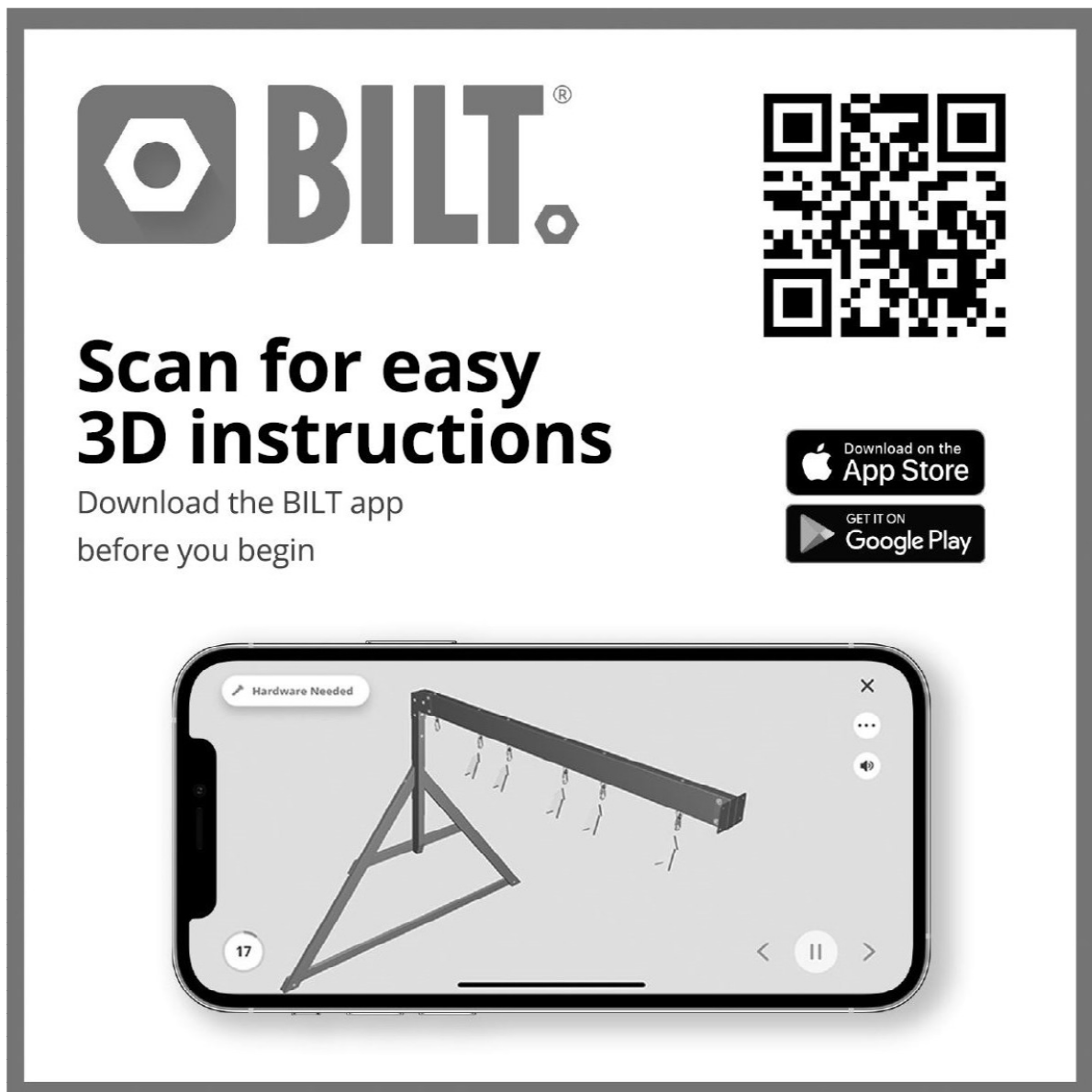

The advertisement features the BILT logo on the left, a QR code on the right, and a smartphone displaying a 3D assembly instruction. The text 'Scan for easy 3D instructions' is prominently displayed in the center. Below the text are buttons for downloading the app from the App Store and Google Play. The smartphone screen shows a 3D model of a metal frame with a horizontal beam and several hanging components. The screen also displays 'Hardware Needed' at the top, a step number '17' in a circle at the bottom left, and navigation icons (back, pause, forward) at the bottom right.

BILT.[®]

**Scan for easy
3D instructions**

Download the BILT app
before you begin

Download on the
App Store

GET IT ON
Google Play

Hardware Needed

17

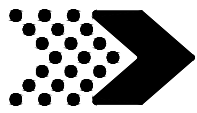

CABANA ASSEMBLY

STEP 1

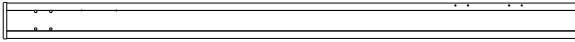

WP1 | W2A02859
(1) | 5 1/2"x5 1/2"x89 5/8" (140x140x2274)

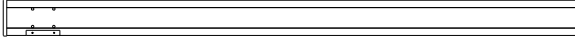

WP3 | W2A02861
(1) | 5 1/2"x5 1/2"x89 5/8" (140x140x2274)



D2 | JOIST - W4L13813
(1) | 1 3/8"x5 1/4"x89 1/2" (36x134x2274)

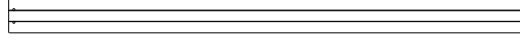

G3 | TOP RAIL - W4L13832
(2) | 1"x5 1/4"x81 1/4" (24x134x2063)

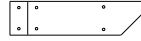

D4 | JOIST END - W4L13815
(1) | 1 3/8"x5 1/4"x18 3/4" (36x134x477)

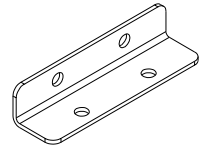

A4M01108 | L BRACKET
(4) | 24x30x112 - BLK



H100363 | BOLT WH BLK
(8) | 5/16x6



H100193 | NUT BARREL WH BLK
(8) | 5/16x1-1/2



H100486 | BOLT WH BLK
(8) | 1/4x5/8



H100399 | NUT BARREL WH BLK
(8) | 1/4x7/8



H100403 | LAG SCREW WH BLK
(8) | 1/4x1 1/2



H100400 | WASHER LOCK EXT BLK
(8) | 8x15



H100198 | WASHER LOCK EXT BLK
(8) | 8x19



H100199 | WASHER LOCK EXT BLK
(8) | 12x19

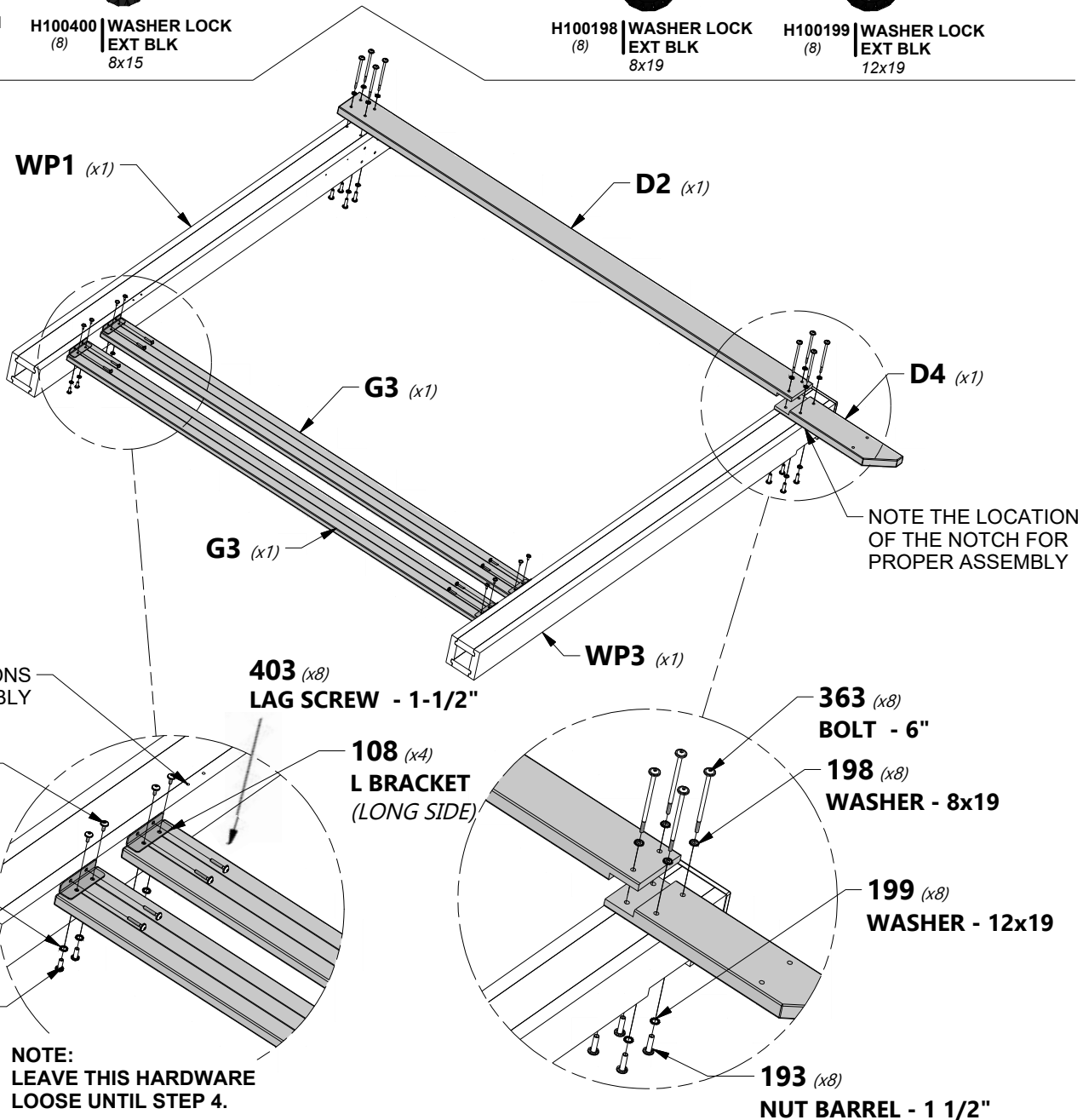

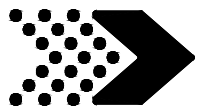

CABANA ASSEMBLY

STEP 2

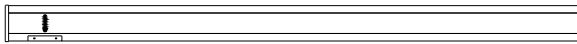

WP2 | W2A02860
(1) | 5 1/2"x5 1/2"x89 5/8" (140x140x2274)

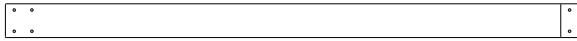

D1 | JOIST - W4L13812
(1) | 1 3/8"x5 1/4"x89 1/2" (36x134x2274)

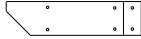

D3 | JOIST END - W4L13814
(1) | 1 3/8"x5 1/4"x18 3/4" (36x134x477)

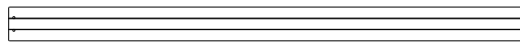

G3 | TOP RAIL - W4L13832
(2) | 1"x5 1/4"x81 1/4" (24x134x2063)

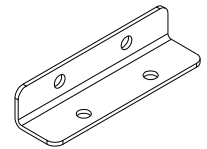

A4M01108 | L BRACKET
(4) | 24x30x112 - BLK



H100363 | BOLT WH BLK
(8) | 5/16x6



H100193 | NUT BARREL WH BLK
(8) | 5/16x1-1/2



H100486 | BOLT WH BLK
(8) | 1/4x5/8



H100399 | NUT BARREL WH BLK
(8) | 1/4x7/8



H100403 | LAG SCREW WH BLK
(8) | 1/4x1 1/2



H100400 | WASHER LOCK EXT BLK
(8) | 8x15



H100198 | WASHER LOCK EXT BLK
(8) | 8x19



H100199 | WASHER LOCK EXT BLK
(8) | 12x19

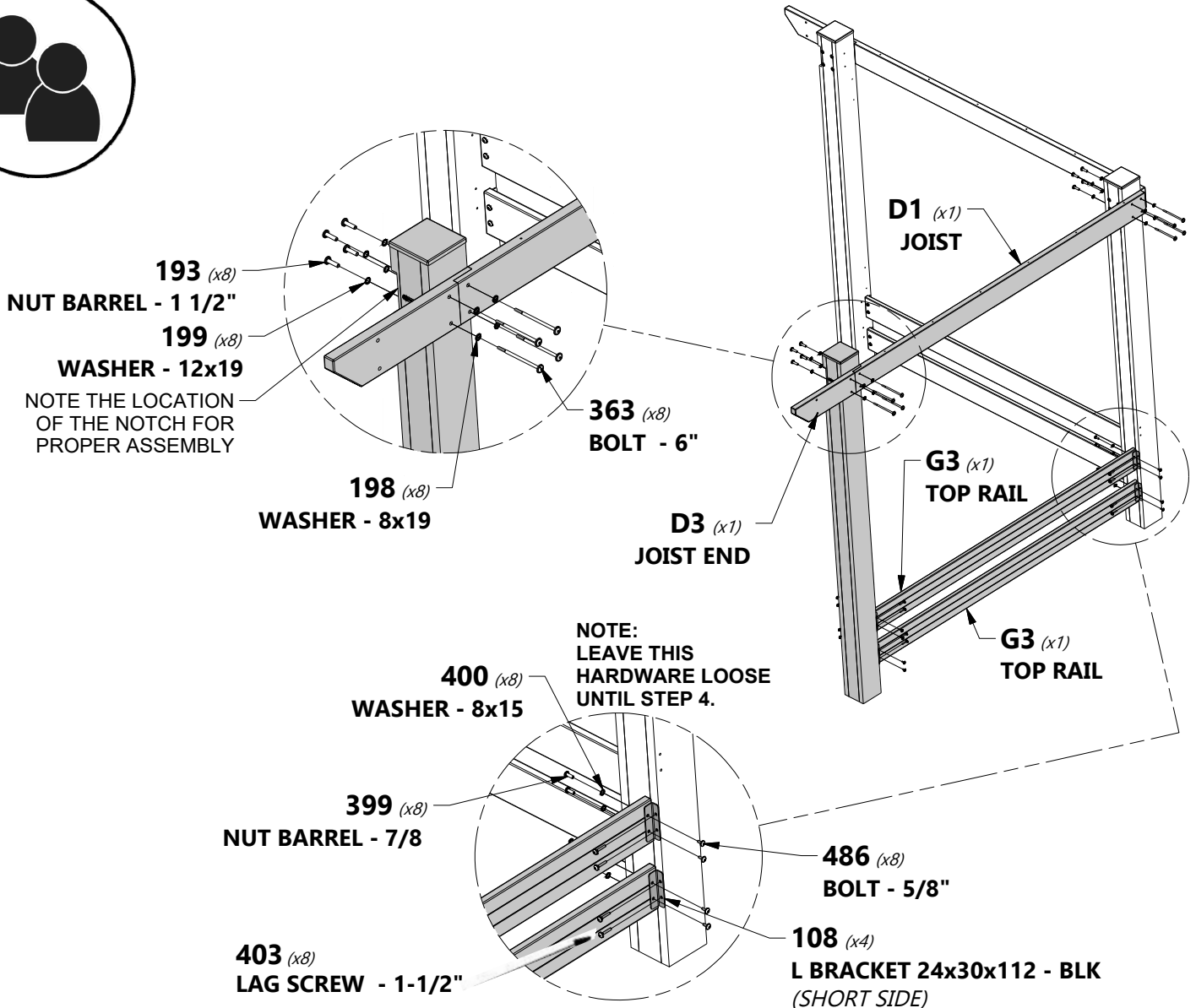

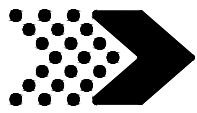

CABANA ASSEMBLY

STEP 3



H100391 | SCREW PFH BLK
(8) | 8x2

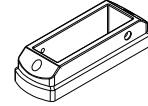

A6P00442 | MOUNTING
(4) | BRACKET

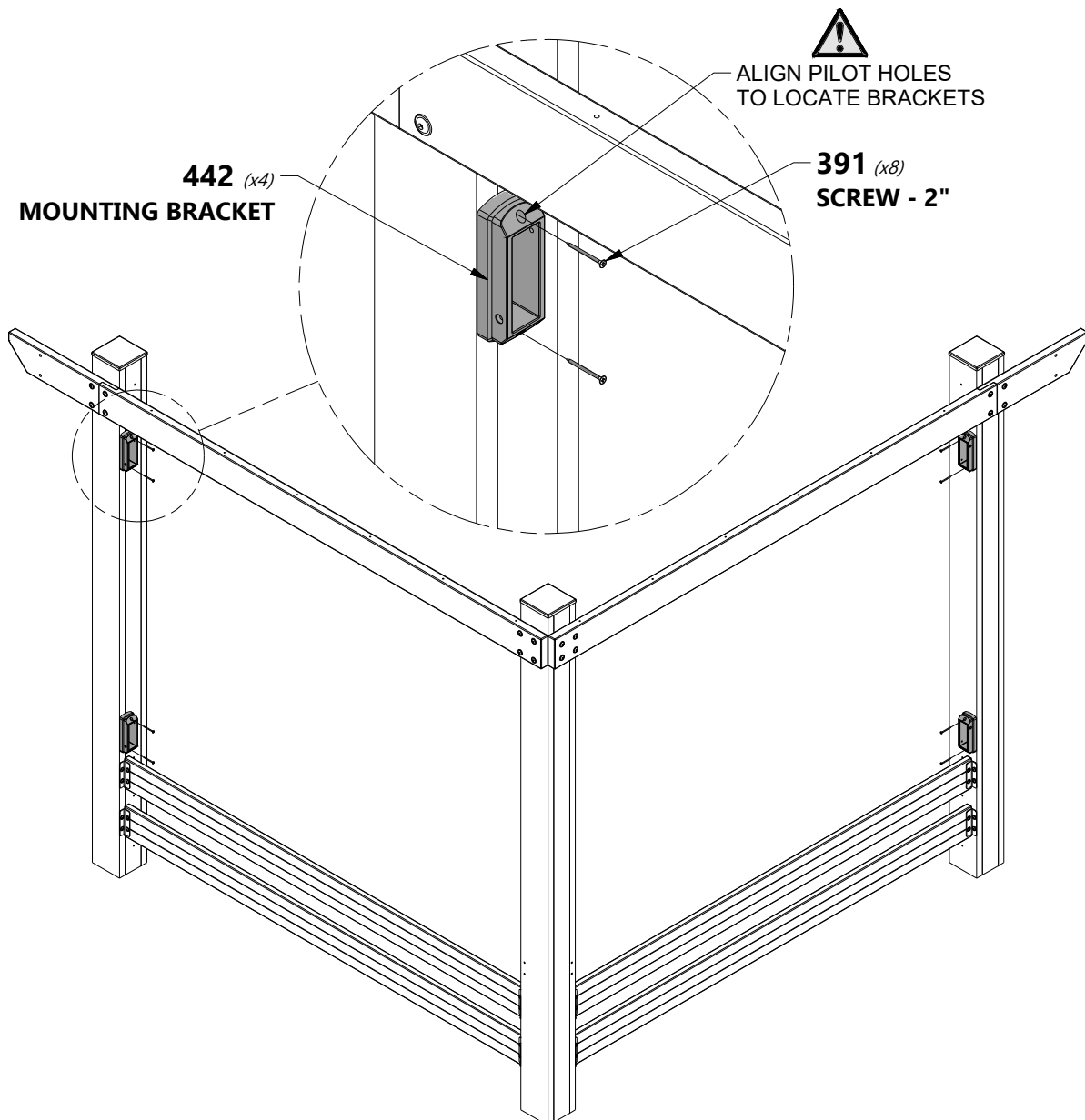

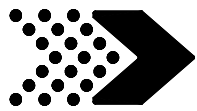

CABANA ASSEMBLY

STEP 4 PREPARATION

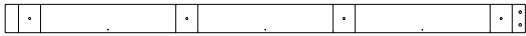

AN1 | LOWER SUPPORT - W4L13810
(1) | 1 3/8"x4 3/8"x81 1/4" (36x112x2064)

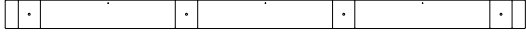

AN2 | TOP SUPPORT - W4L13809
(2) | 1 3/8"x4 3/8"x81 1/4" (36x112x2064)

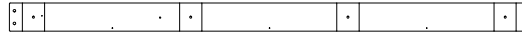

AN3 | LOWER SUPPORT - W4L13835
(1) | 1 3/8"x4 3/8"x81 1/4" (36x112x2064)

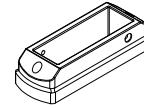

A6P00442 | MOUNTING BRACKET
(2)

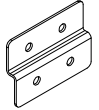

A4M01166 | L BRACKET
(2) | 40x40x112 - BLK



H100407 | BOLT WH BLK
(4) | 5/16x1 1/2



H100379 | T-NUT BLK
(4) | 5/16



H100385 | SCREW PFH BLK
(4) | 8x1

PREPARATION LEFT SUPPORTS

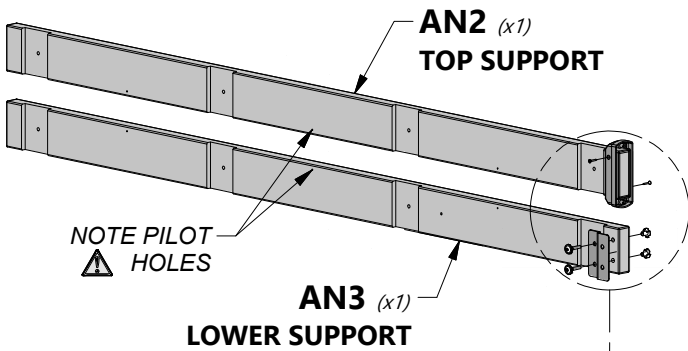

PREPARATION RIGHT SUPPORTS

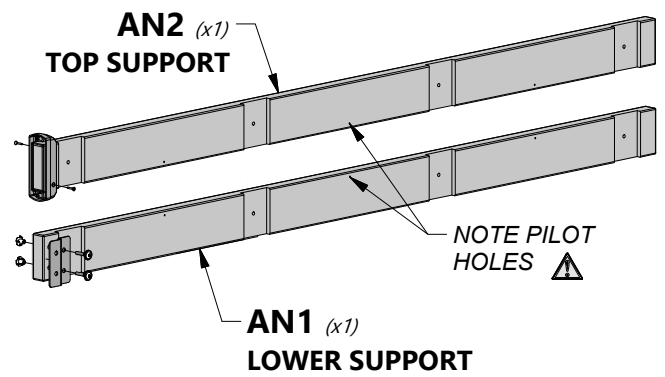

REPEAT STEPS SHOWN FOR RIGHT & LEFT SUPPORTS

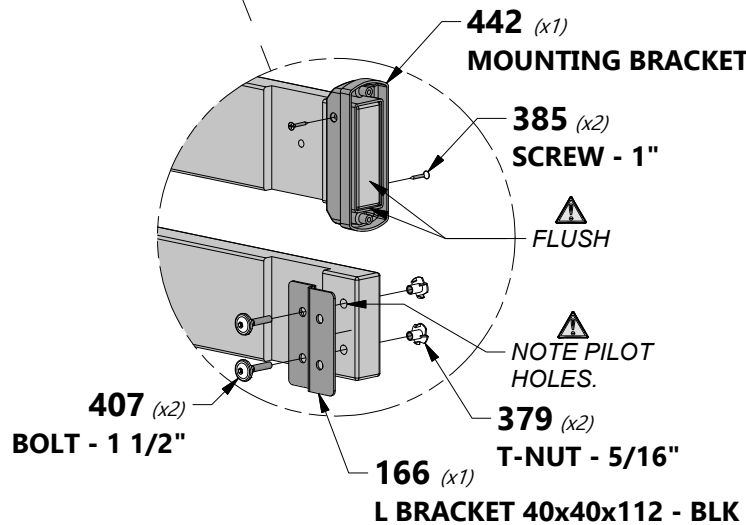

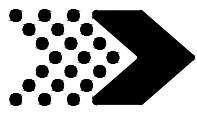

CABANA ASSEMBLY

STEP 4



LEFT SUPPORTS FROM PREVIOUS STEP

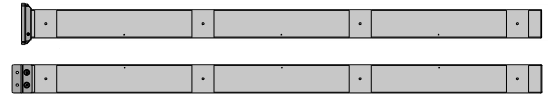

RIGHT SUPPORTS FROM PREVIOUS STEP



H100471 | LAG SCREW WH
(4) | BLK
5/16x1 1/2



H100391 | SCREW PFH BLK
(4) | 8x2



H100385 | SCREW PFH BLK
(8) | 8x1

NOTE:
TIGHTEN ALL HARDWARE
FROM PREVIOUS STEPS.

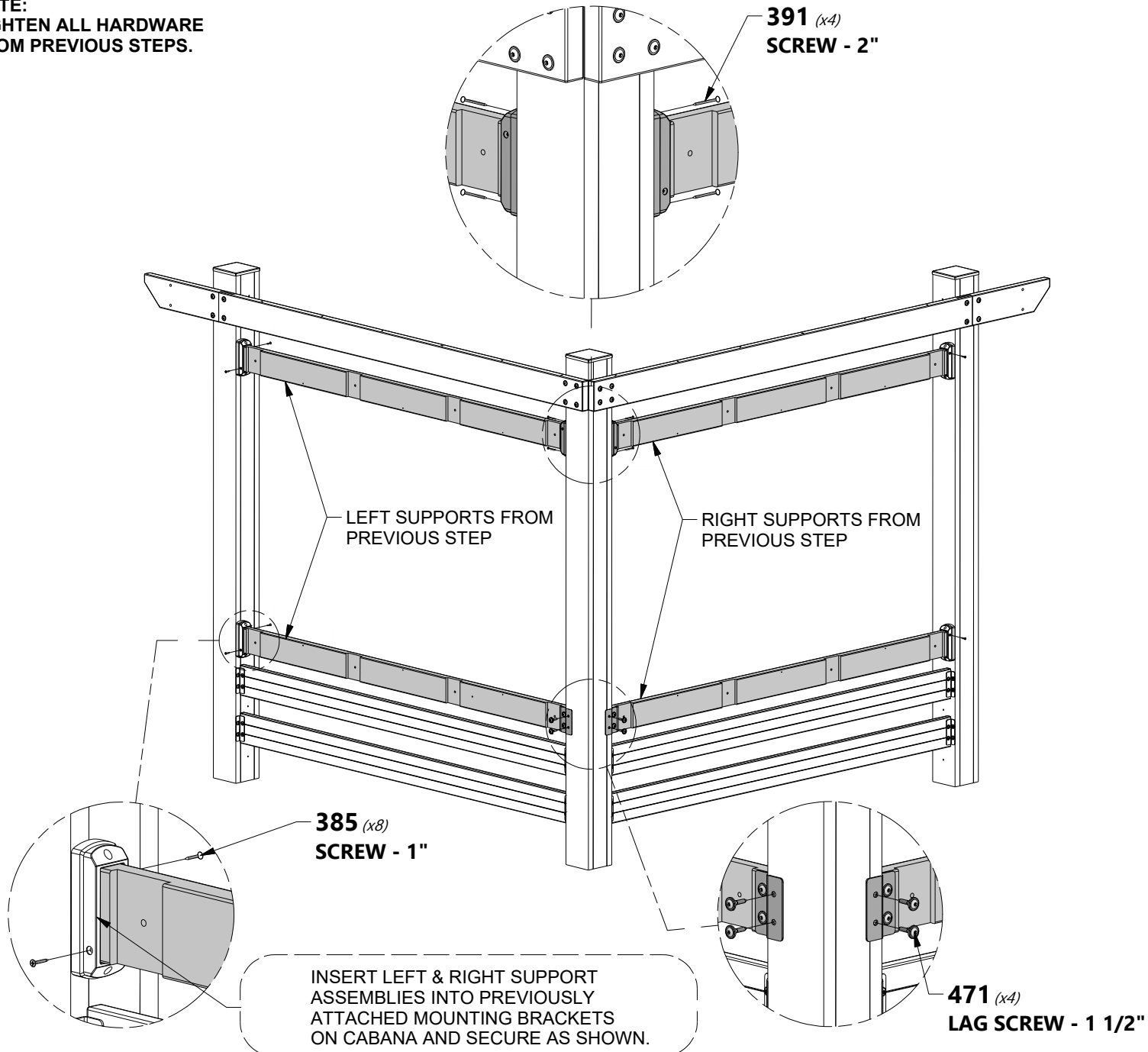

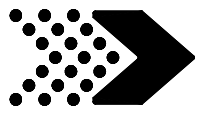

CABANA ASSEMBLY

STEP 5

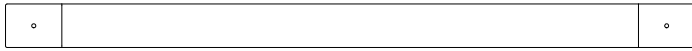

H1 | VERTICAL SUPPORT - W4L13808
(8) | 1"x3 3/8"x53 7/8" (24x86x1368)



H100400 | WASHER LOCK
(16) | EXT BLK
8x15



H100405 | WASHER LOCK
(16) | EXT BLK
6x15



H100171 | BOLT WH BLK
(16) | 1/4x1



H100399 | NUT BARREL
(16) | WH BLK
1/4x7/8

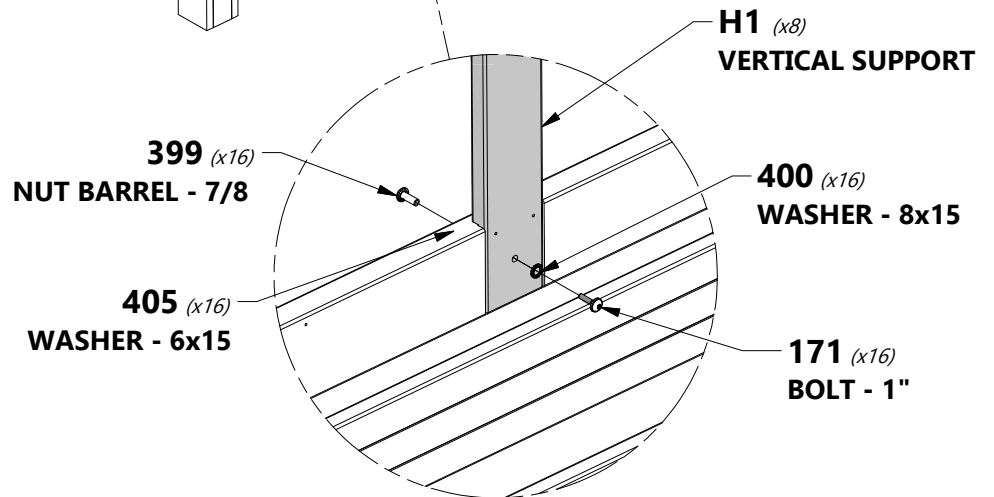
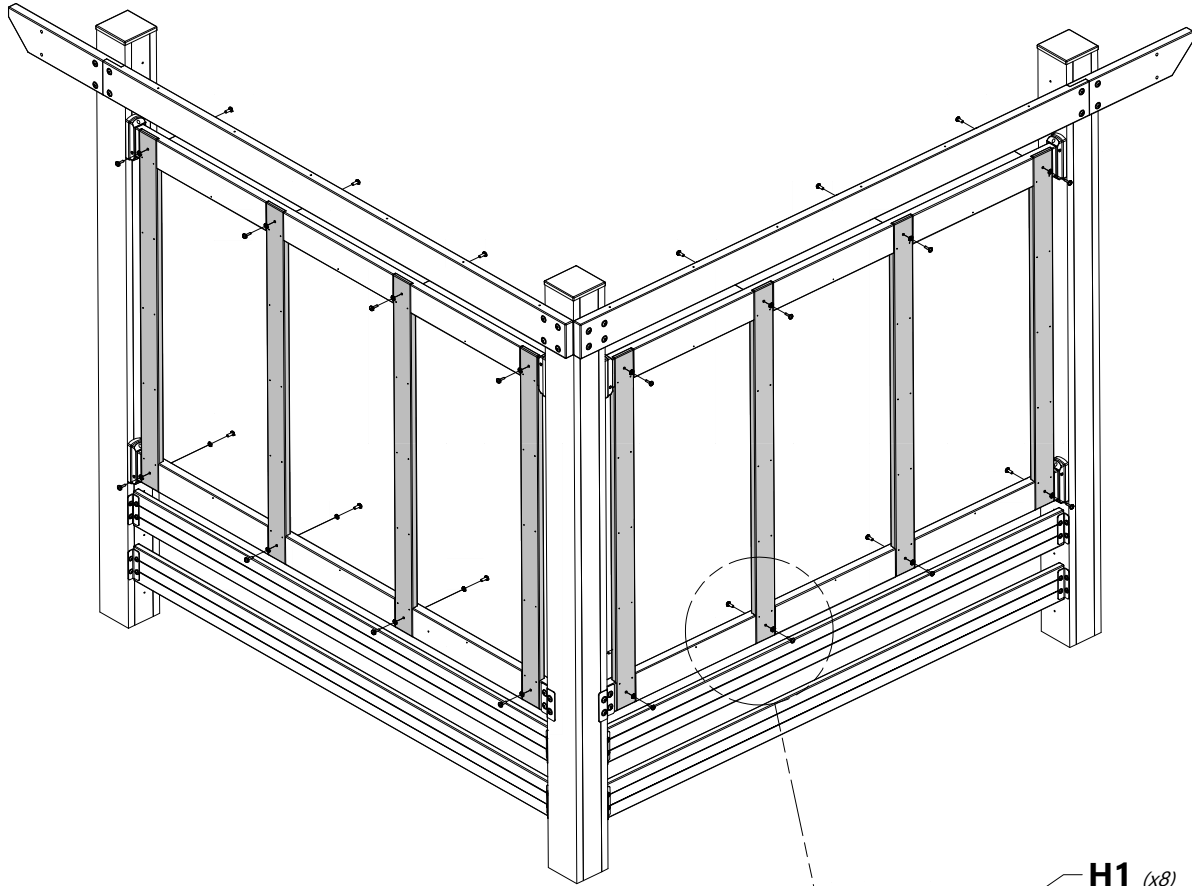

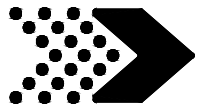

CABANA ASSEMBLY

STEP 6



G8 | BEAM - W4L13817
(1) | 1"x5 1/4"x89 1/2" (24x134x2274)

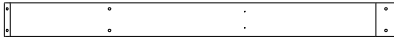

G12 | BEAM - W4L13821
(1) | 1"x5 1/4"x61 1/4" (24x134x1555)

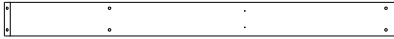

G13 | BEAM - W4L13822
(1) | 1"x5 1/4"x61 1/4" (24x134x1555)

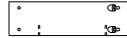

G11 | BEAM END - W4L13820
(1) | 1"x5 1/4"x19" (24x134x484)



G15 | BEAM END - W4L13831
(1) | 1"x5 1/4"x19" (24x134x484)

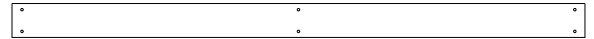

A4M01111 | METAL BEAM
(1)



H100407 | BOLT WH BLK
(6) | 5/16x1 1/2



H100192 | NUT BARREL
(6) | WH BLK
5/16x7/8



H100199 | WASHER LOCK
(6) | EXT BLK
12x19



H100198 | WASHER LOCK
(6) | EXT BLK
8x19

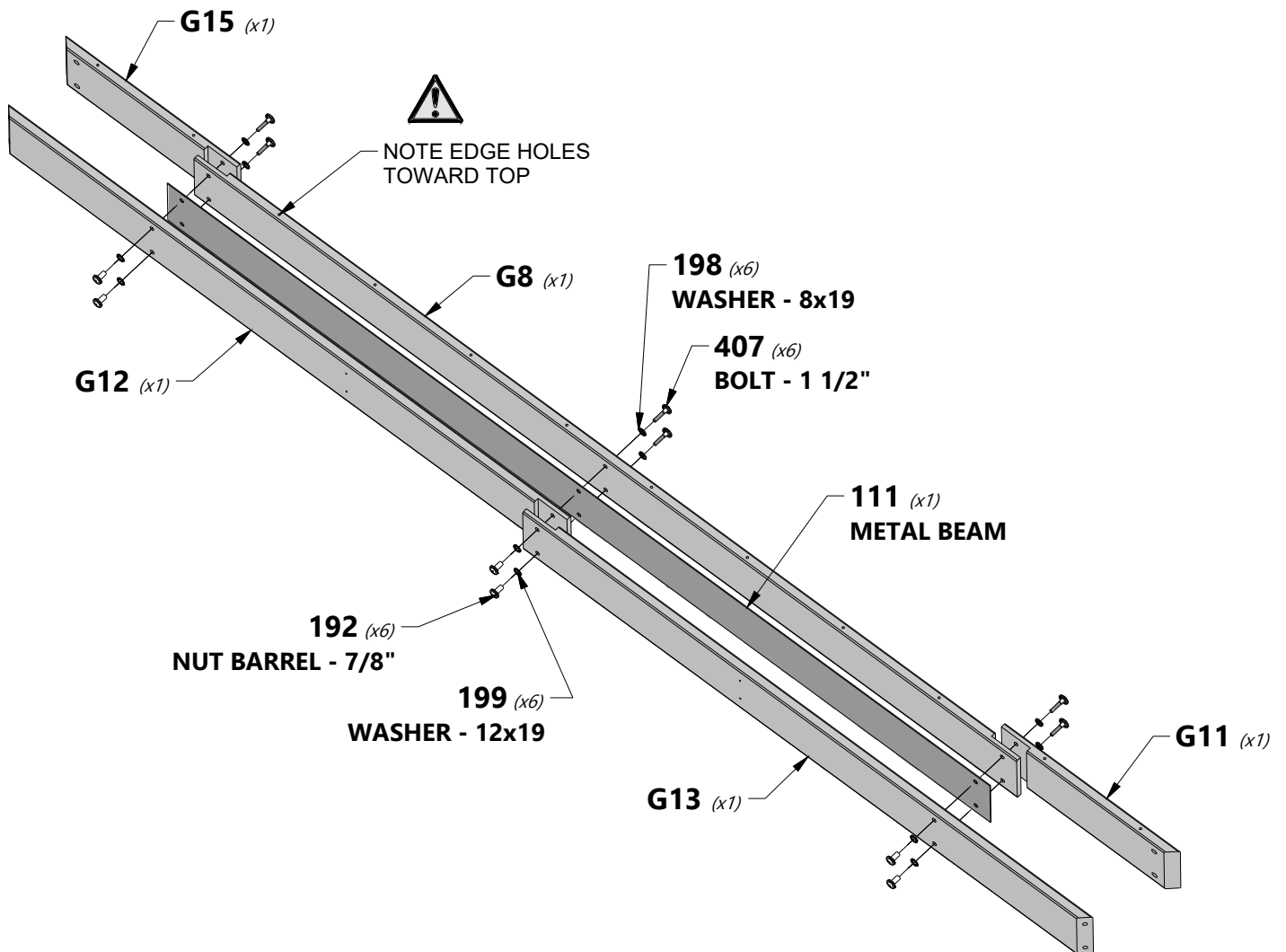

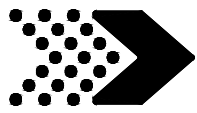

CABANA ASSEMBLY

STEP 7



(1) REAR BEAM SUBASSEMBLY



H100197 | LAG SCREW WH BLK
(4) | 5/16x2 1/2



H100198 | WASHER LOCK
(4) | EXT BLK
8x19

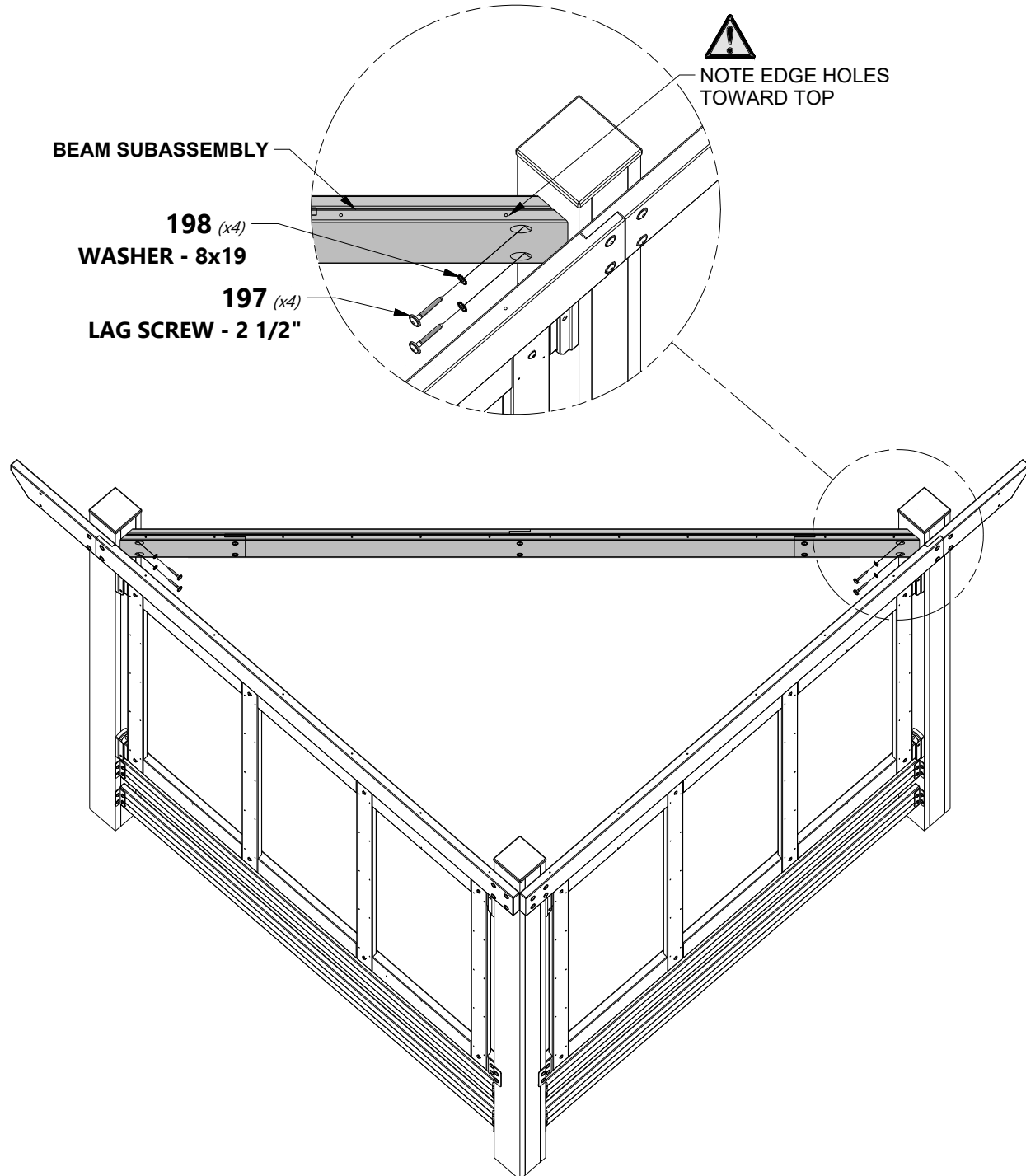

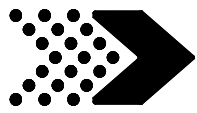

CABANA ASSEMBLY

STEP 8

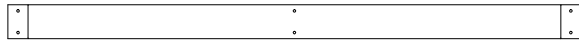

G8 | BEAM - W4L13817
(1) | 1"x5 1/4"x89 1/2" (24x134x2274)



G9 | BEAM - W4L13818
(1) | 1"x5 1/4"x71 1/8" (24x134x1807)



G10 | BEAM - W4L13819
(1) | 1"x5 1/4"x71 1/8" (24x134x1807)

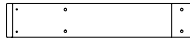

G7 | BEAM END - W4L13816
(1) | 1"x5 1/4"x29" (24x134x736)



G14 | BEAM END - W4L13830
(1) | 1"x5 1/4"x29" (24x134x736)

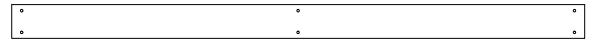

A4M01111 | METAL BEAM
(1)

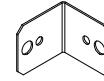

A4M00555 | 90° L-BRACKET - BLK
(4)



H100407 | BOLT WH BLK
(6) | 5/16x1 1/2



H100192 | NUT BARREL WH BLK
(6) | 5/16x7/8



H100199 | WASHER LOCK EXT BLK
(6) | 12x19



H100198 | WASHER LOCK EXT BLK
(6) | 8x19



H100202 | SCREW PWH BLK
(4) | 8x5/8

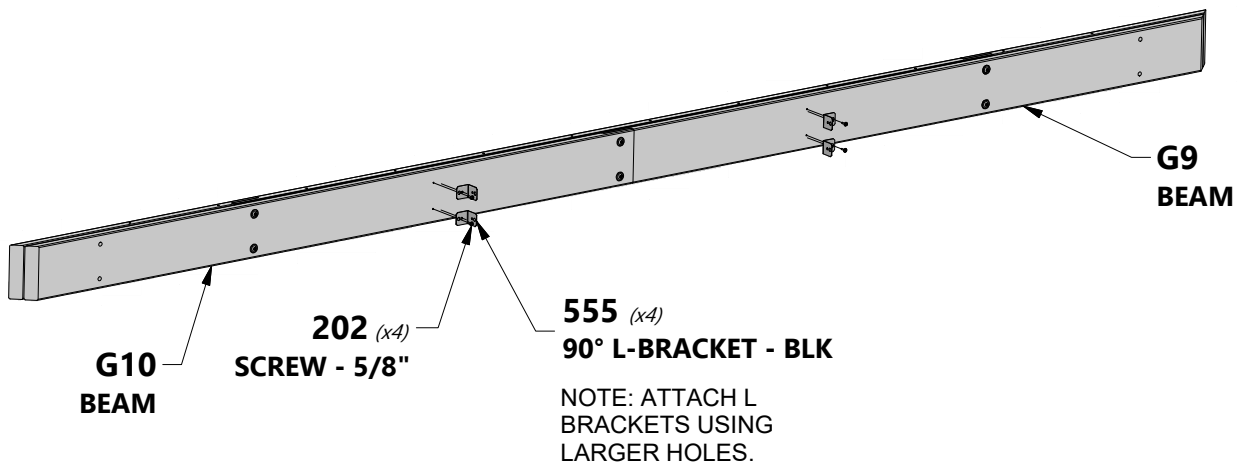
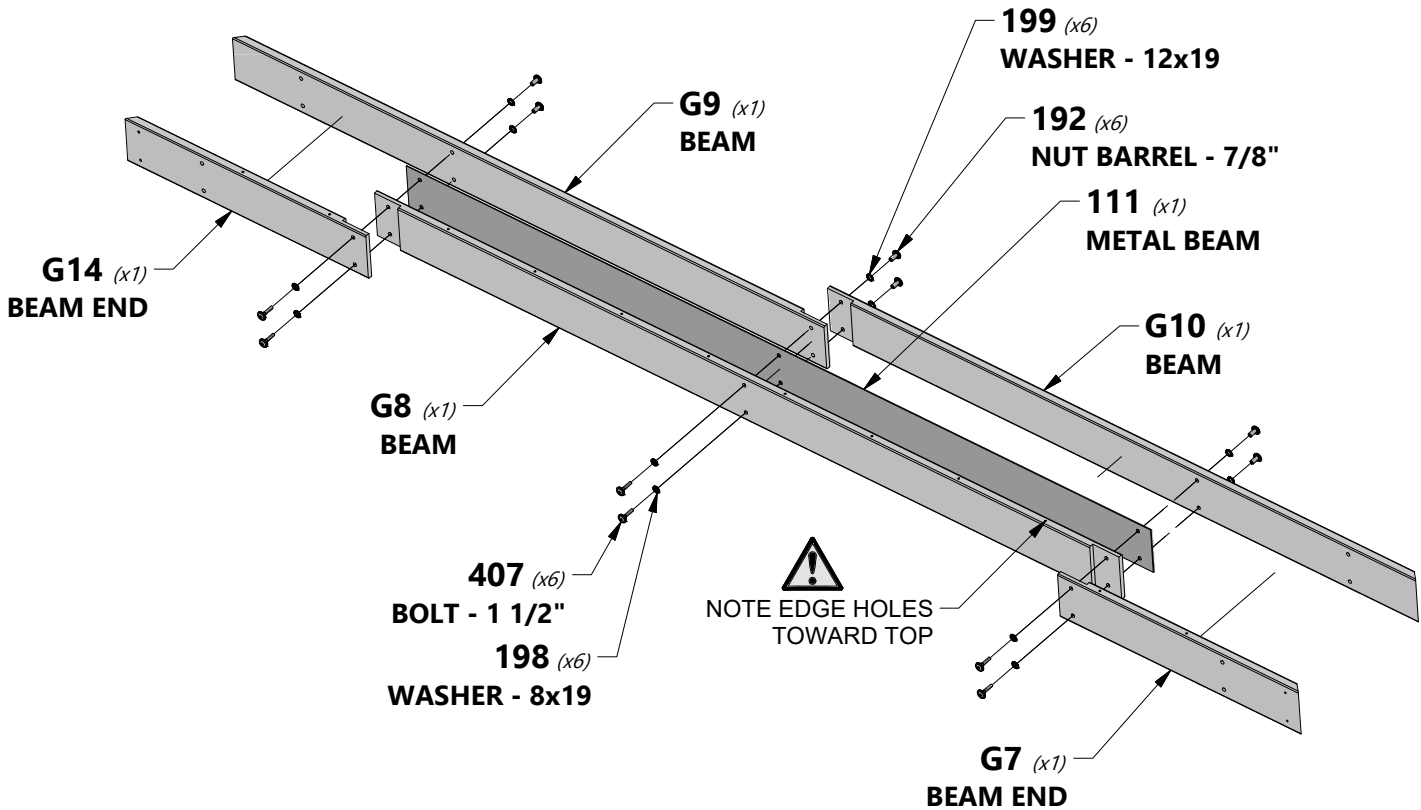

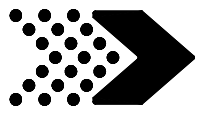

CABANA ASSEMBLY

STEP 9



D5 | SUPPORT BRACE - W4L13823
(2) | 1 3/8"x5 1/4"x4 5/8" (36x134x116)



H100202 | SCREW PWH BLK
(8) | 8x5/8

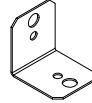

A4M00555 | 90° L-BRACKET - BLK
(4) | BLK

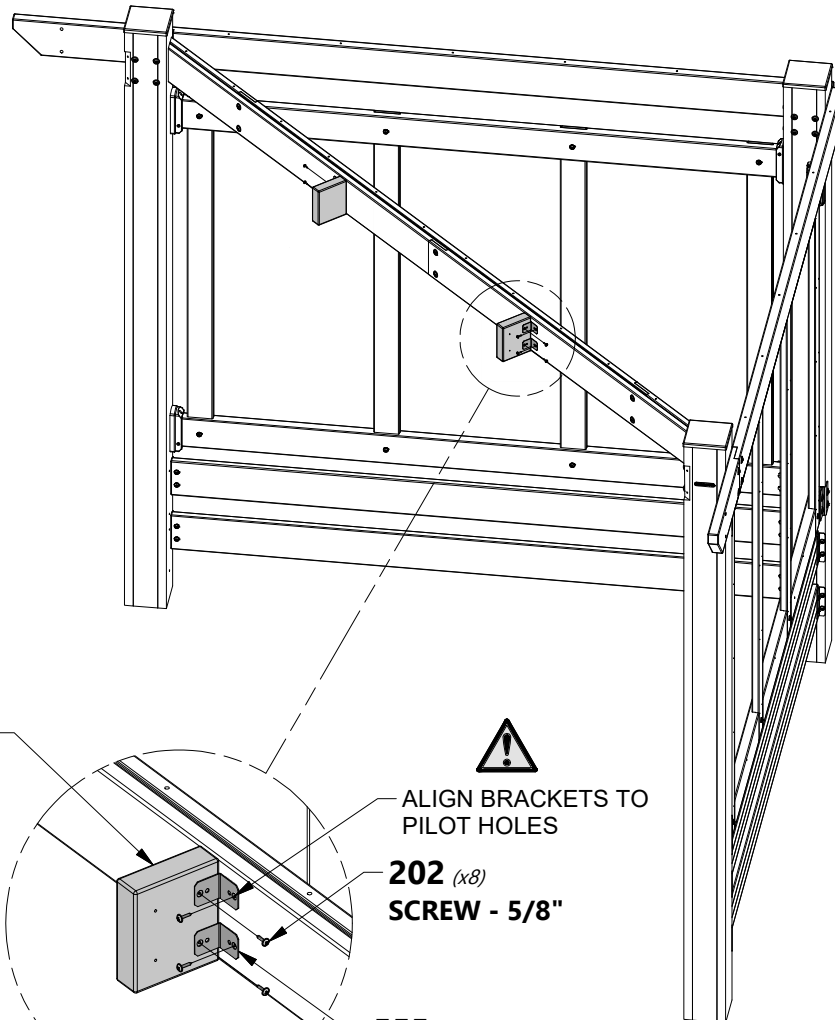

D5 (x2)
SUPPORT BRACE



ALIGN BRACKETS TO
PILOT HOLES

202 (x8)
SCREW - 5/8"

555 (x4)
90° L-BRACKET - BLK

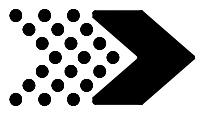

CABANA ASSEMBLY

STEP 10



(1) FRONT BEAM SUBASSEMBLY



H100202 | SCREW PWH BLK
(4) | 8x5/8

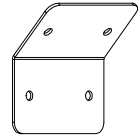

A4M01097 | BRACKET 135°
(2) | BLK



H100206 | LAG SCREW WH BLK
(4) | 5/16x3



H100471 | LAG SCREW WH BLK
(4) | 5/16x1 1/2



H100468 | BOLT WH BLK
(4) | 5/16x1



H100192 | NUT BARREL
(4) | WH BLK
5/16x7/8



H100199 | WASHER LOCK
(4) | EXT BLK
12x19



H100198 | WASHER LOCK
(4) | EXT BLK
8x19

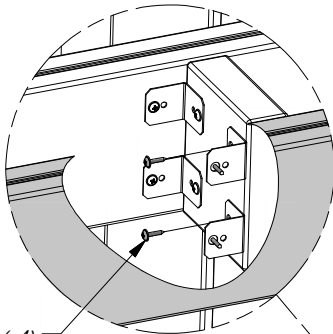

202 (x4)
SCREW - 5/8"

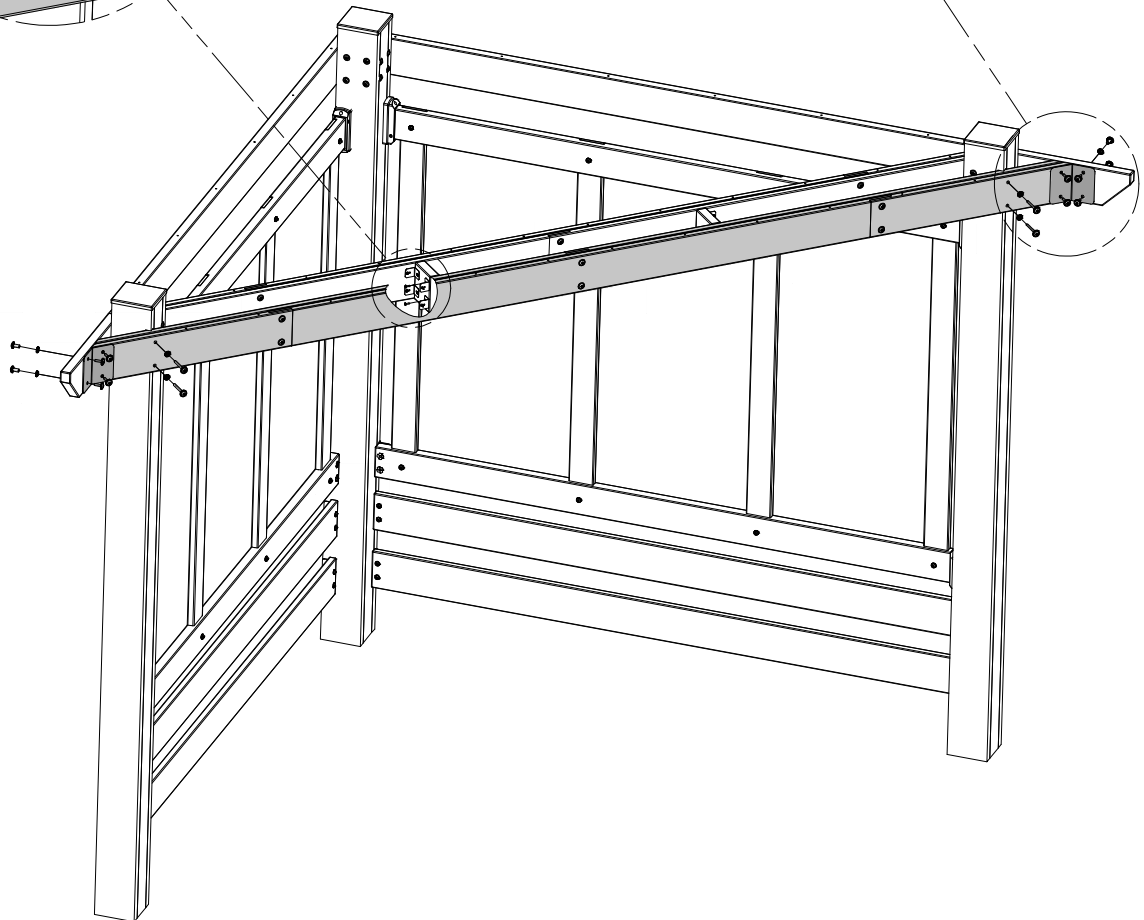
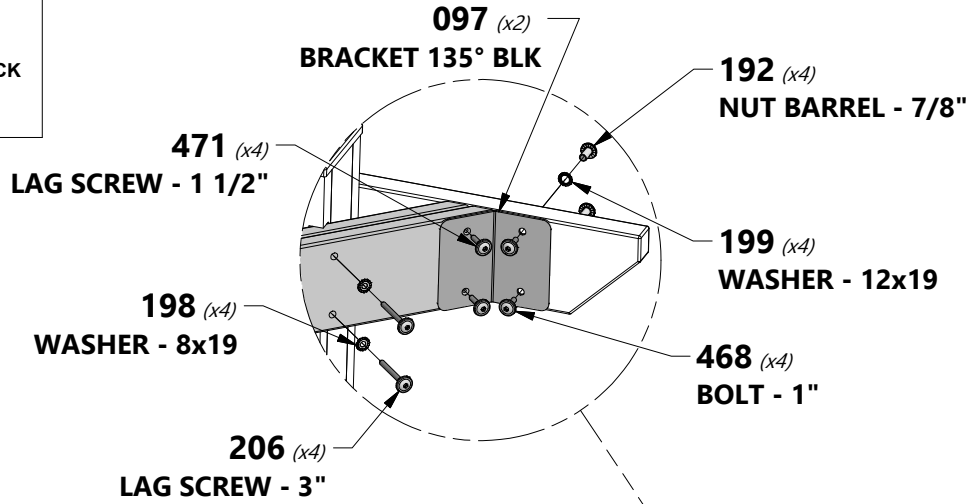

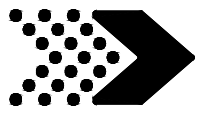

CABANA ASSEMBLY

STEP 11

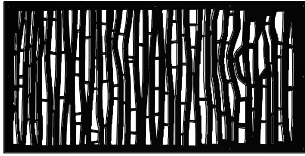

A6P00440
(6) | DECORATIVE BACK PANEL

OR

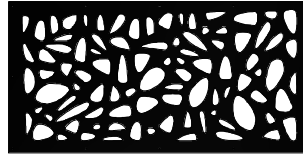

A6P00441
(6) | DECORATIVE BACK PANEL



H100797 | SCREW PWH BLK
(72) | 8x1



1. ALTERNATE TOP AND BOTTOM AS SHOWN BELOW.
2. TEXTURED SIDE OF PANEL FACES INWARD.

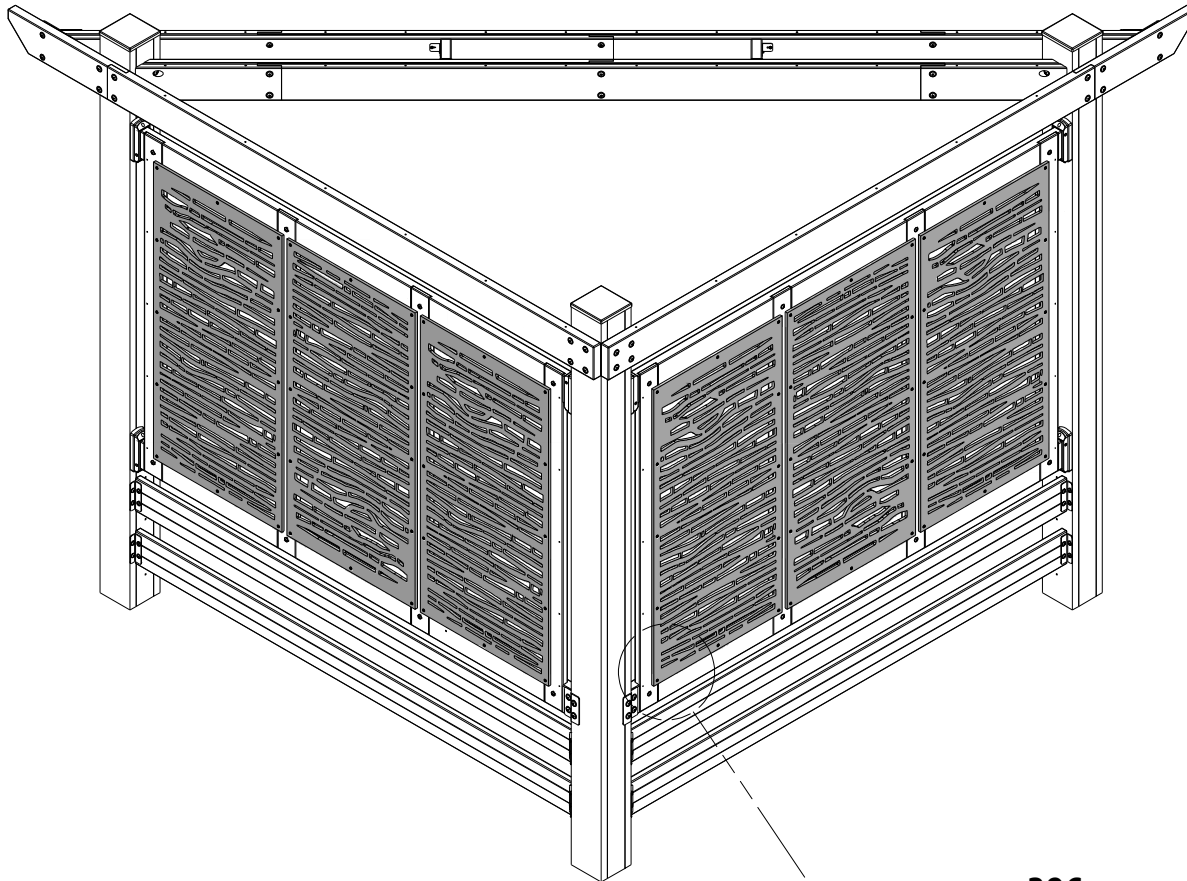

396 (x6)
DECORATIVE BACK PANEL

TOP

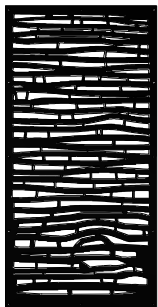

OR

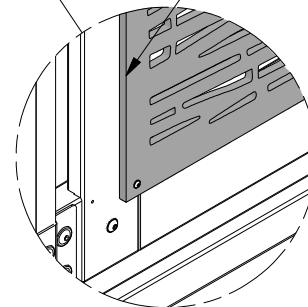
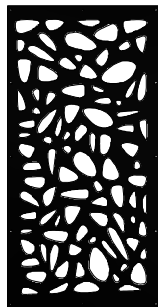

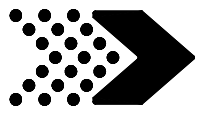

CABANA ASSEMBLY

STEP 12

E1 | TOP JOIST - W4L13824
(2) | 1 3/8"x3 3/8"x81 1/2" (36x86x2070)

E2 | TOP JOIST - W4L13825
(2) | 1 3/8"x3 3/8"x71 1/2" (36x86x1817)

E3 | TOP JOIST - W4L13826
(2) | 1 3/8"x3 3/8"x61 1/8" (36x86x1553)

E6 | TOP JOIST - W4L13829
(2) | 1 3/8"x3 3/8"x30" (36x86x761)

E5 | TOP JOIST - W4L13828
(2) | 1 3/8"x3 3/8"x40 3/8" (36x86x1025)

E4 | TOP JOIST - W4L13827
(2) | 1 3/8"x3 3/8"x50 3/4" (36x86x1289)



H100198 | WASHER LOCK
(36) | **EXT BLK**
8x19

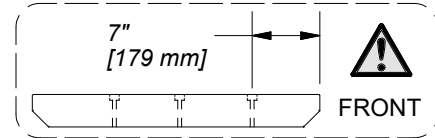
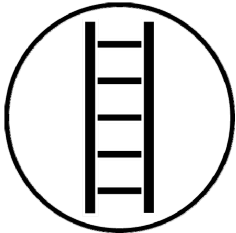

825 (x36)
LAG 5/16x4 BLK

198 (x36)
WASHER - 8x19

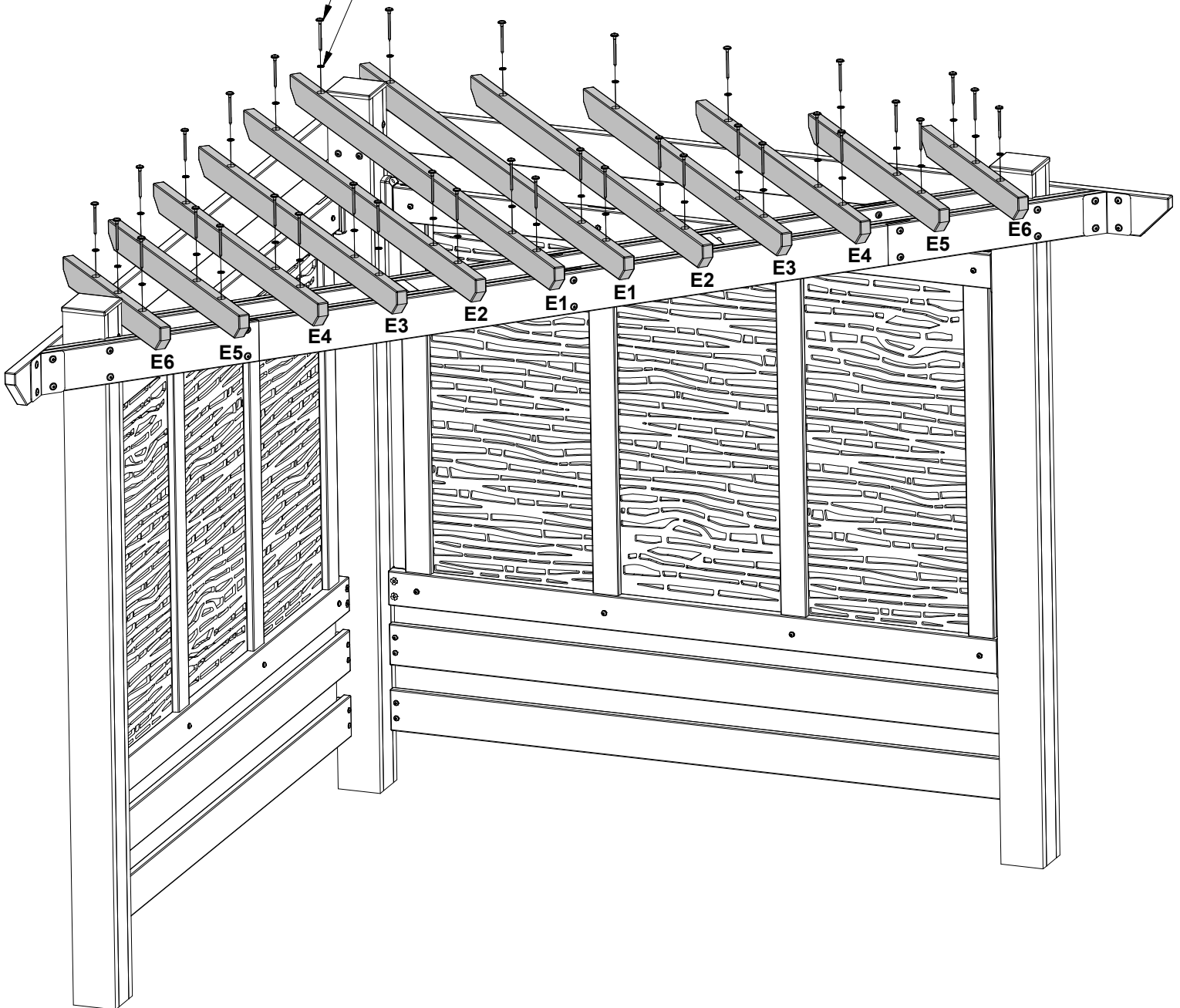

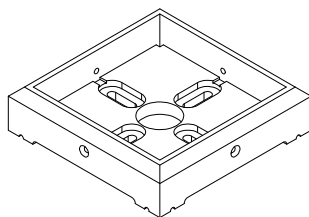
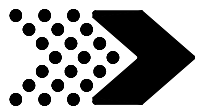

A100029 | FOOT 142
(3) SQUARE POST



1. DECIDE WHERE TO PLACE THE PERGOLA. NOTE THIS MOUNTING PROCEDURE IS MEANT TO BE USED ON CONCRETE ONLY.

2. PLACE THE PERGOLA EXACTLY WHERE IT WILL BE ANCHORED WHEN COMPLETED AND SLIDE A FOOT UNDER EACH POST.

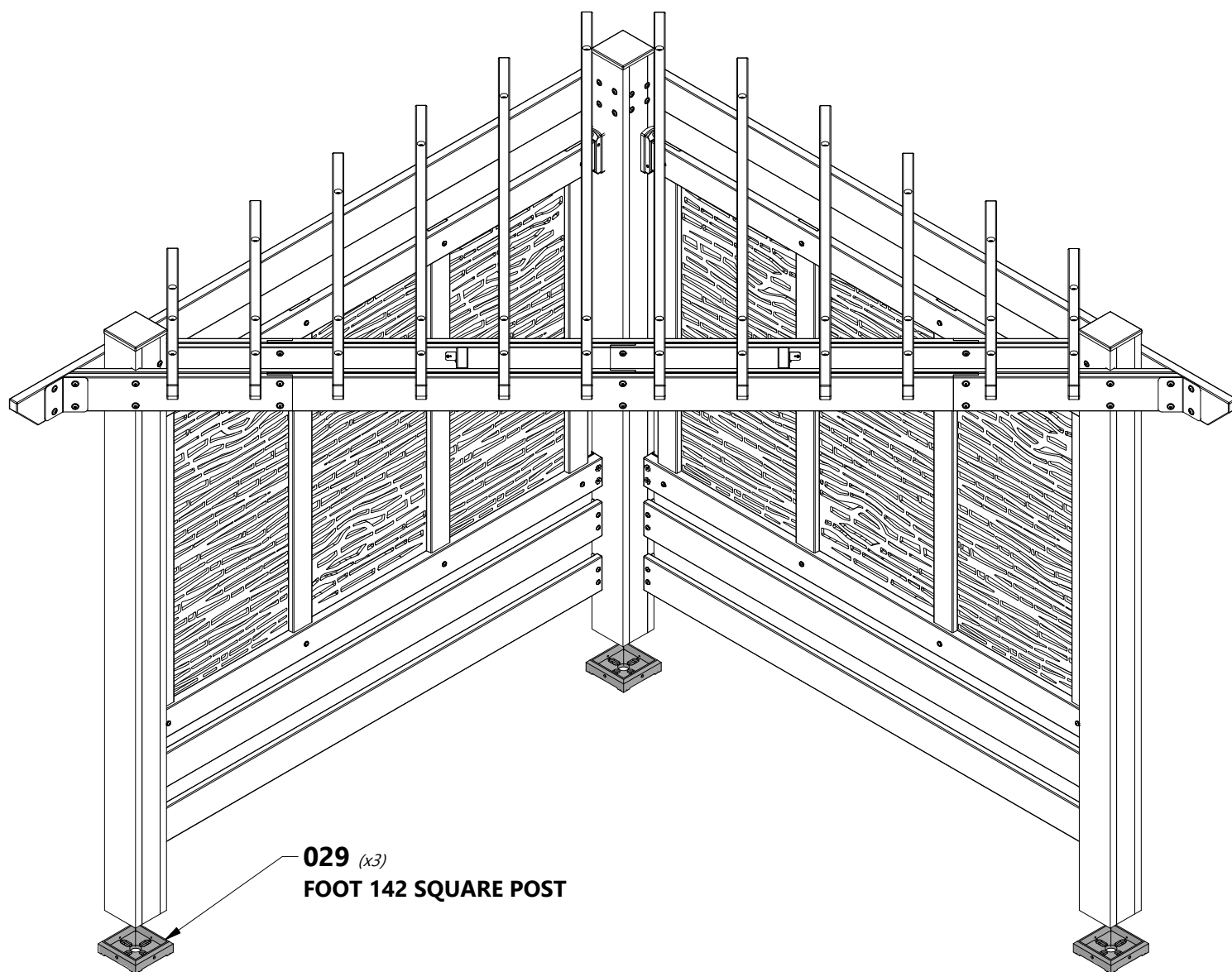

029 (x3)
FOOT 142 SQUARE POST

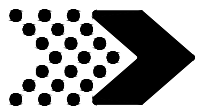

H100120 | SCREW CONCRETE ANCHOR
(12) | 1/4x2



USE CHALK TO TRACE AROUND THE EDGES OF EACH FOOT.

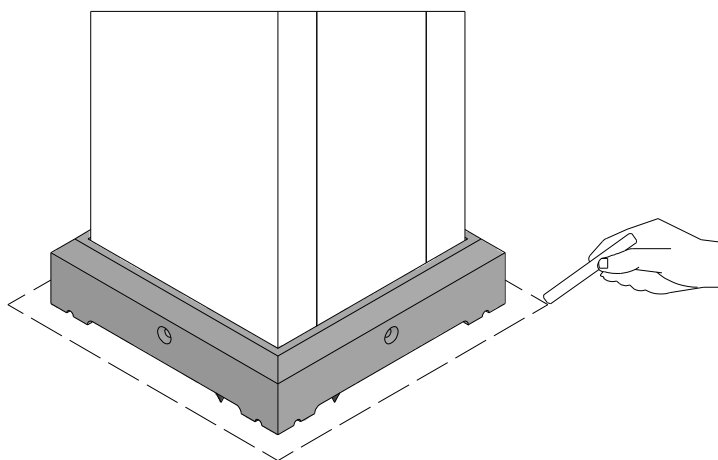

1. MOVE THE PERGOLA ASIDE. PLACE EACH FOOT INSIDE OF THE LINES DRAWN IN THE PREVIOUS STEP. USING A 3/16" CONCRETE DRILL BIT, PILOT DRILL ATTACHMENT HOLES INTO THE CONCRETE PAD.

2. USE THE 1/4"x2" CONCRETE ANCHORS TO ATTACH EACH FOOT TO THE CONCRETE SURFACE.

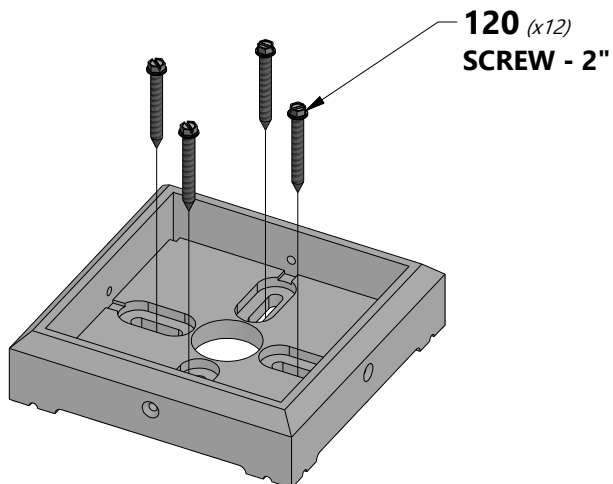

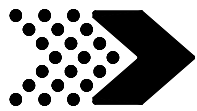

ANCHORING

STEP 15



A100241 | **BYD ID TAG**
(1) | **(SMALL)**
WITHOUT AGES



H100200 | **SCREW PFH BLK**
(12) | **8x1 1/2**



H100392 | **SCREW PWH BLK**
(2) | **8x3/4**



MOVE THE PERGOLA BACK IN TO PLACE, SETTING EACH POST INSIDE A FOOT AND MOUNT.

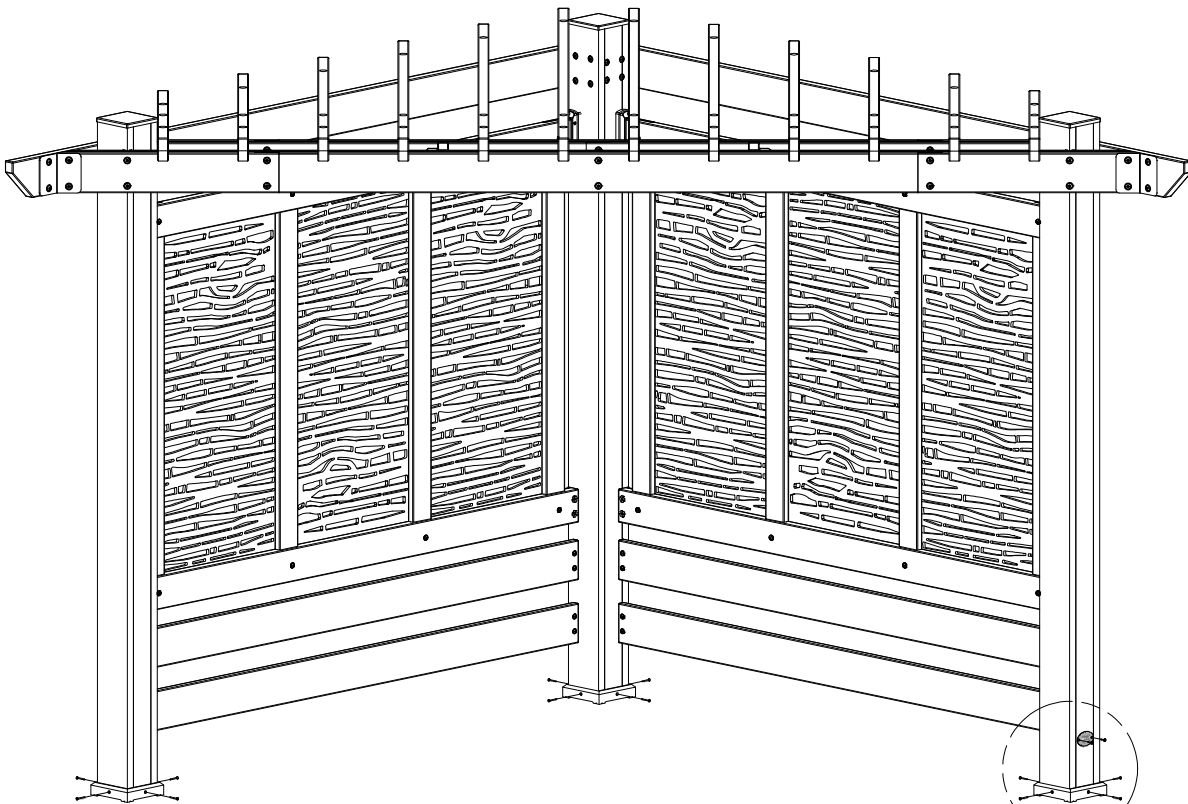

241 *(x1)*
BYD ID TAG

392 *(x2)*
SCREW - 3/4"

200 *(x12)*
SCREW - 1 1/2"

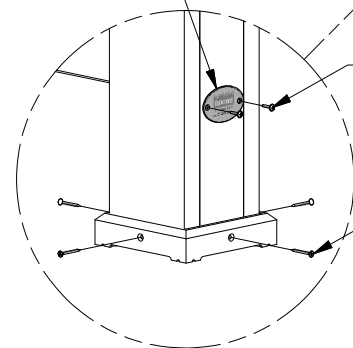



PRODUCT IS FINISHED

FOR CUSTOMERS ASSEMBLING MODELS:

**2002517, 2002524, 2002531, 2202555, 2202562,
2002579, OR 2002586 CONTINUE ON TO NEXT STEP.**

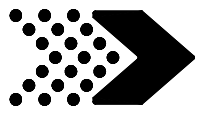

SEATING ASSEMBLY

STEP 16

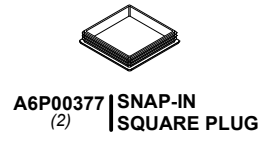
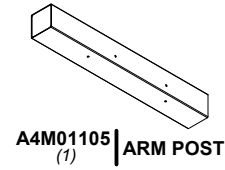
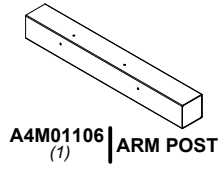
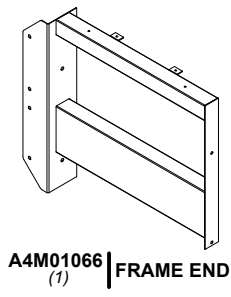
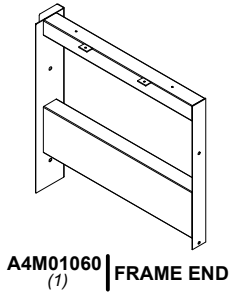

H100171 | BOLT WH BLK
(4) | 1/4x1

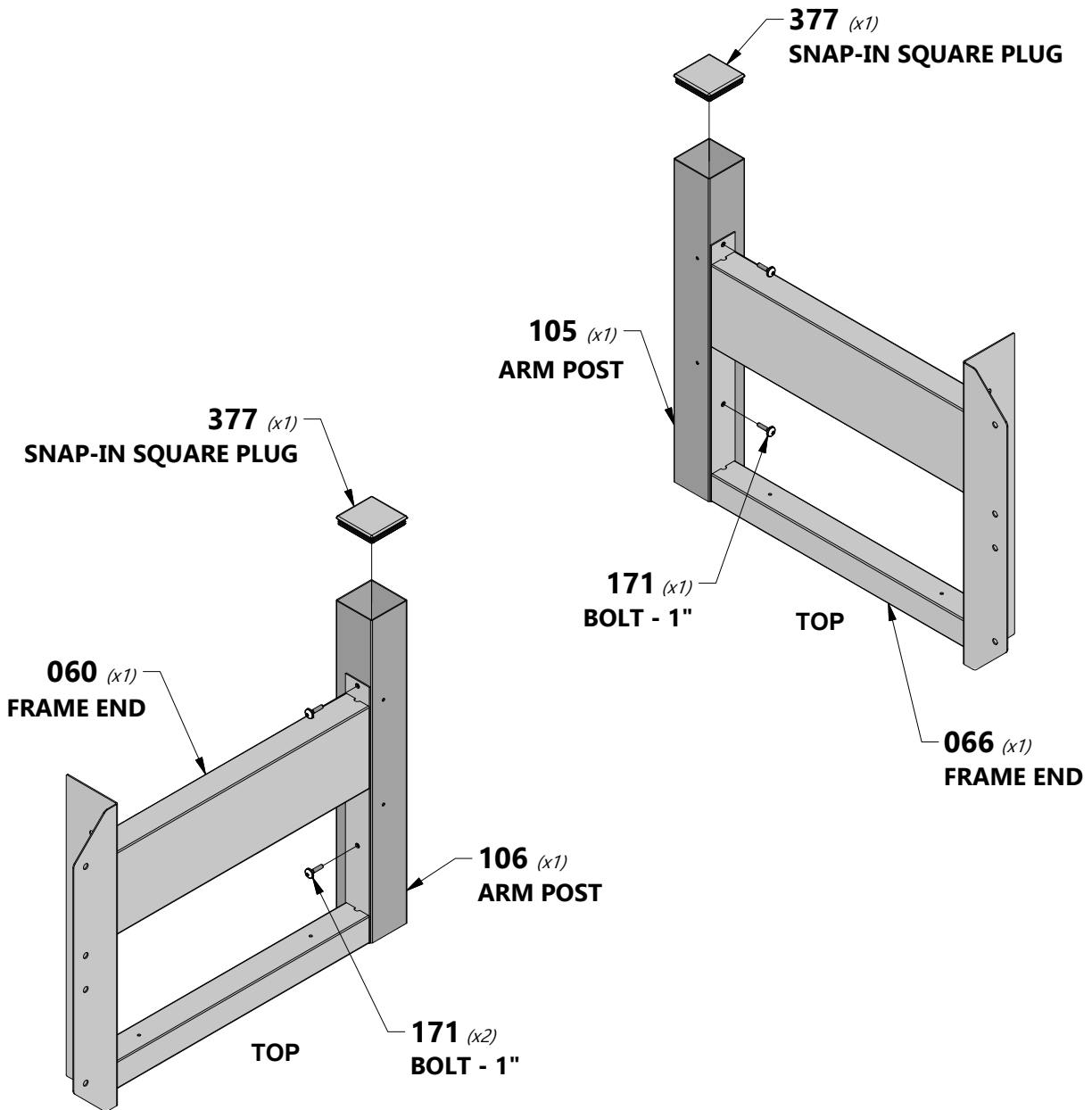

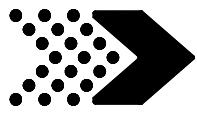

SEATING ASSEMBLY

STEP 17

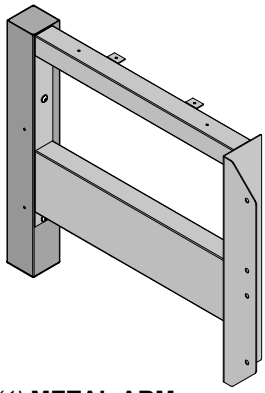

(1) METAL ARM SUBASSEMBLY - LEFT

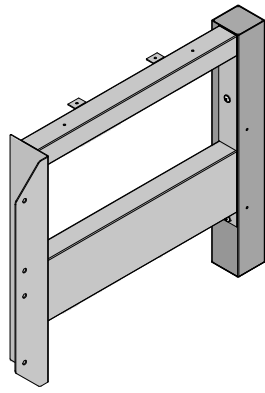

(1) METAL ARM SUBASSEMBLY - RIGHT



H100471 | LAG SCREW WH BLK
(10) | 5/16x1 1/2



NOTE:

LOCATE AND USE ARMREST ASSEMBLY HOLES AS A TEMPLATE. MARK AND DRILL HOLES SECURING METAL ARMRESTS TO POST. USE THE 6mm DRILL BIT PROVIDED IN HARDWARE KIT TO DRILL 3/8" [10mm] DEEP HOLES. USE HARDWARE PROVIDED.

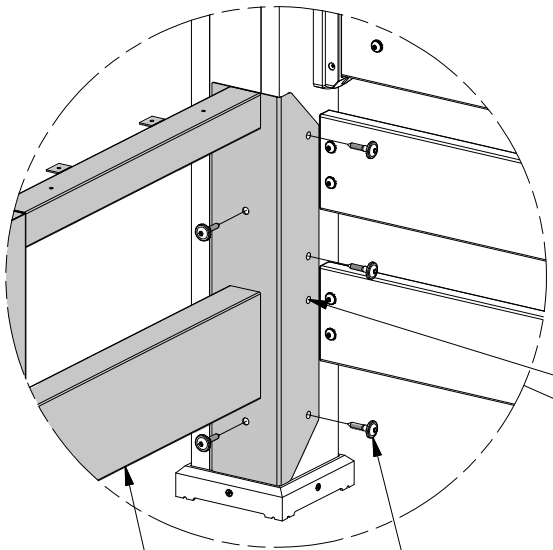

(1) METAL ARM SUBASSEMBLY - LEFT



DO NOT DRILL THIS HOLE

471 (x10)
LAG SCREW - 1 1/2"

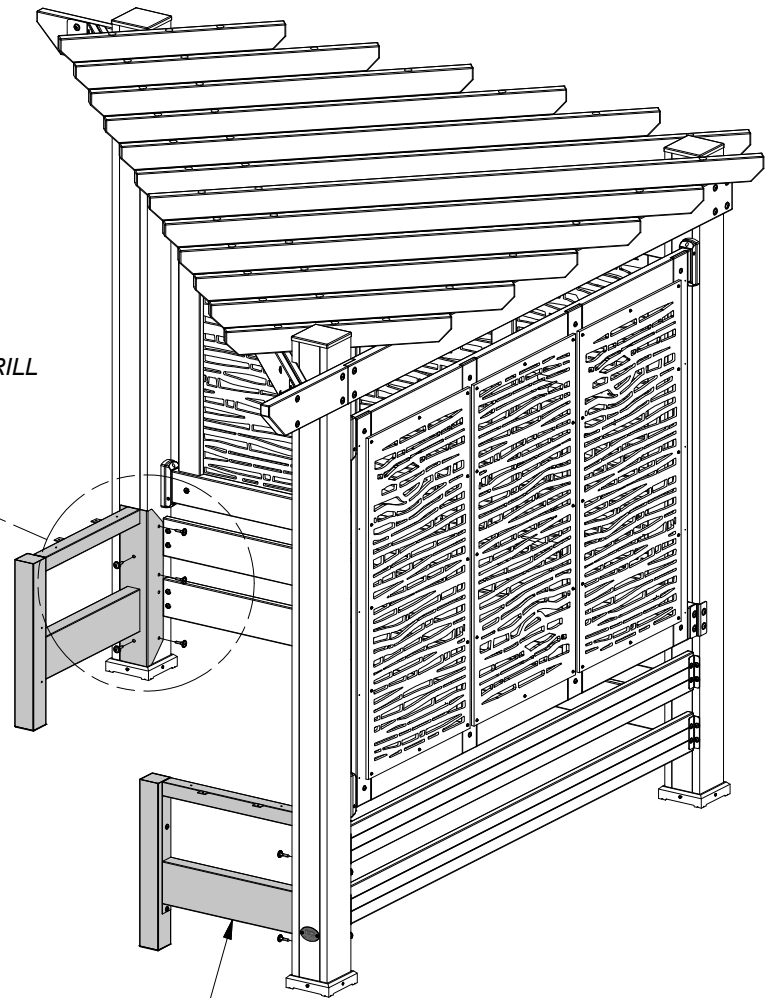

(1) METAL ARM SUBASSEMBLY - RIGHT

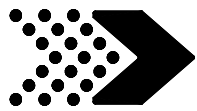

SEATING ASSEMBLY

STEP 18

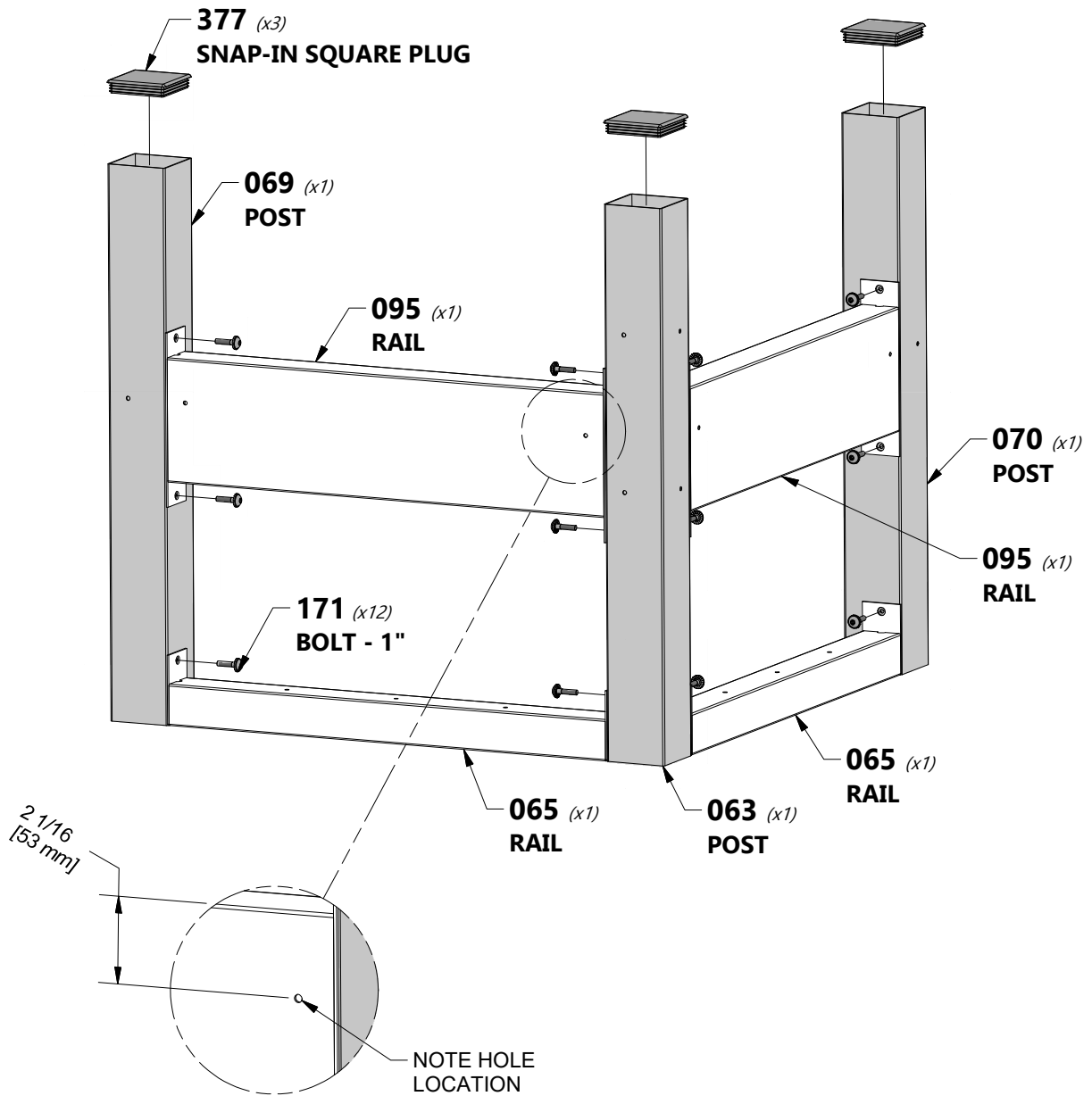
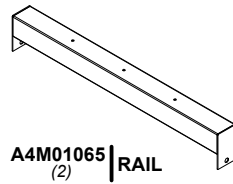
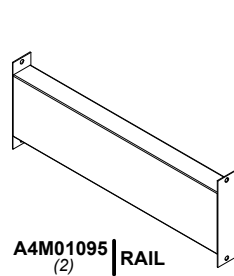
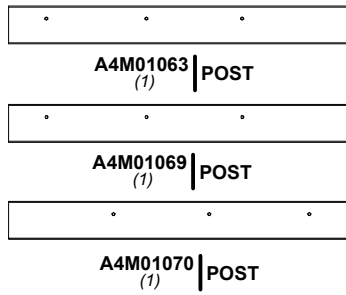

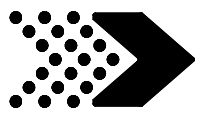

SEATING ASSEMBLY

STEP 19

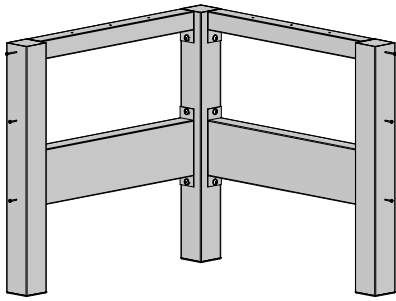

(1) METAL TABLE BASE SUBASSEMBLY



H100391 | SCREW PFH BLK
(6) | 8x2

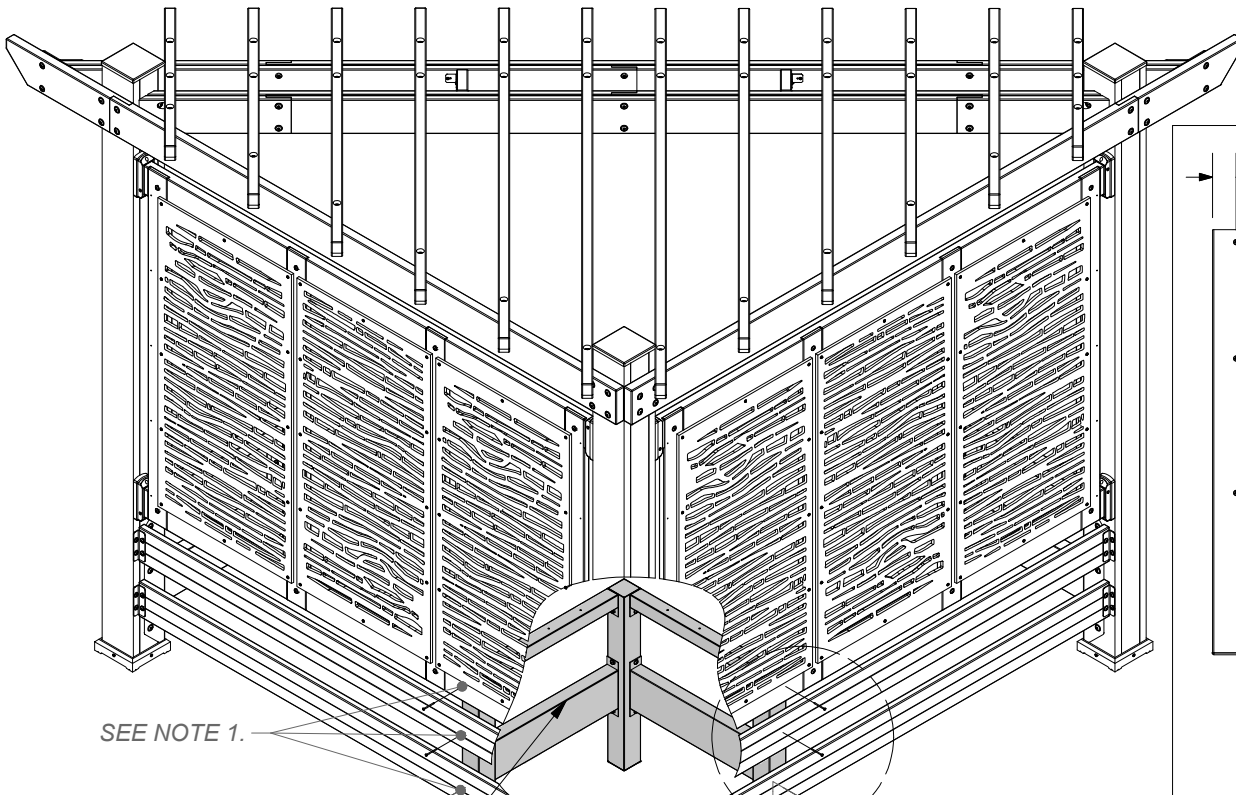

SEE NOTE 1.

METAL ARM TABLE BASE SUBASSEMBLY (FROM STEP 18)

23 1/2 in [598 mm]

23 1/2 in [598 mm]

NOTE: DIMS TAKEN FROM INSIDE OF LEG TO C/L OF SCREWS.

DRILLING LOCATIONS

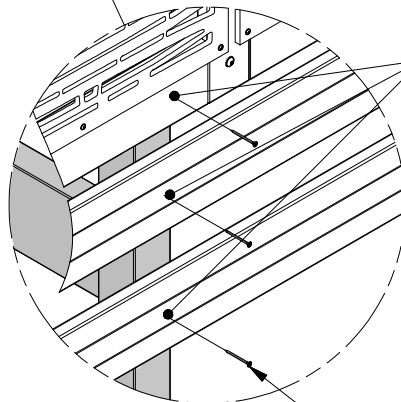
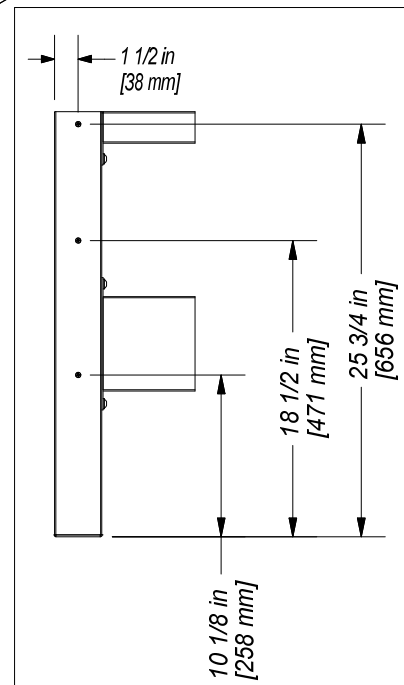

SEE NOTE 1.

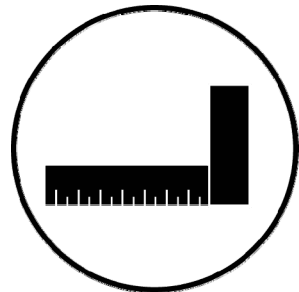

391 (x6)
SCREW - 2"



NOTE:

1. MARK & DRILL A 3/16" [5mm] THROUGH HOLE IN DRILLING LOCATIONS.
2. USE HARDWARE SHOWN TO ATTACH METAL TABLE FRAME TO CABANA.

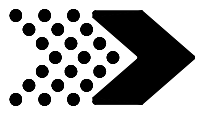

SEATING ASSEMBLY

STEP 20

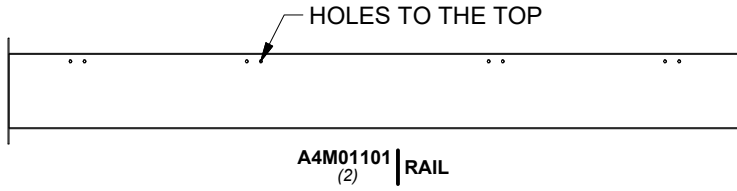

H100171 | BOLT WH BLK
(8) | 1/4x1

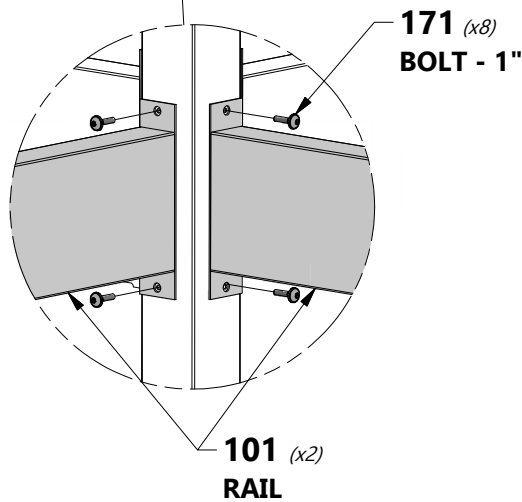
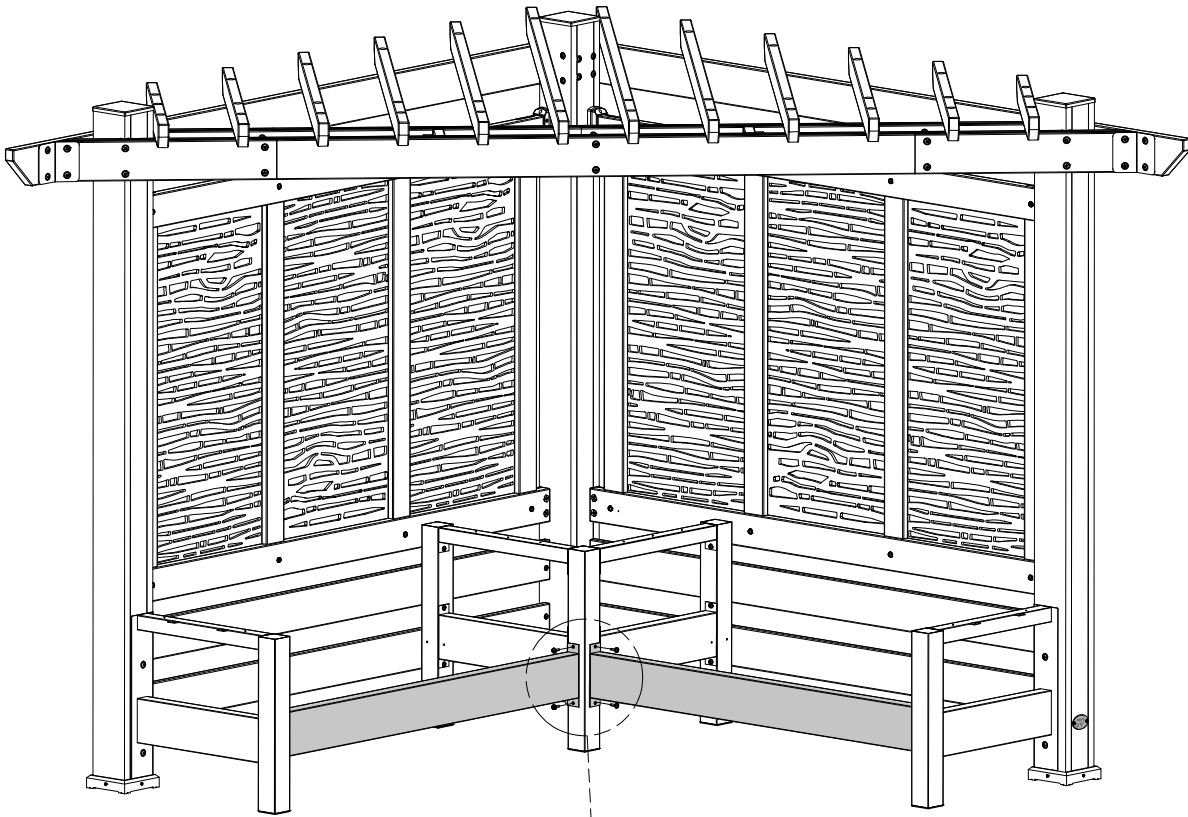

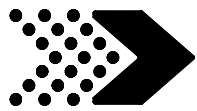

SEATING ASSEMBLY

STEP 21

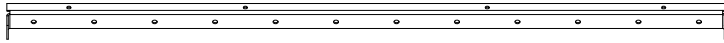

A4M01102 | ANGLED RAIL
(4)

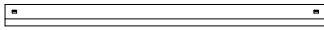

A4M01064 | SUPPORT
(24)



H100712 | BOLT CARRIAGE BLK
(48) | 5/16x1 1/2



H100479 | NUT LOCK BLK
(48) | 5/16



H100770 | WASHER FLAT
(48) | BLK
5/16



LOOSELY TIGHTEN SEAT SUPPORT FRAME FOR EASIER ATTACHMENT TO METAL FRAME AND CABANA RAILS!

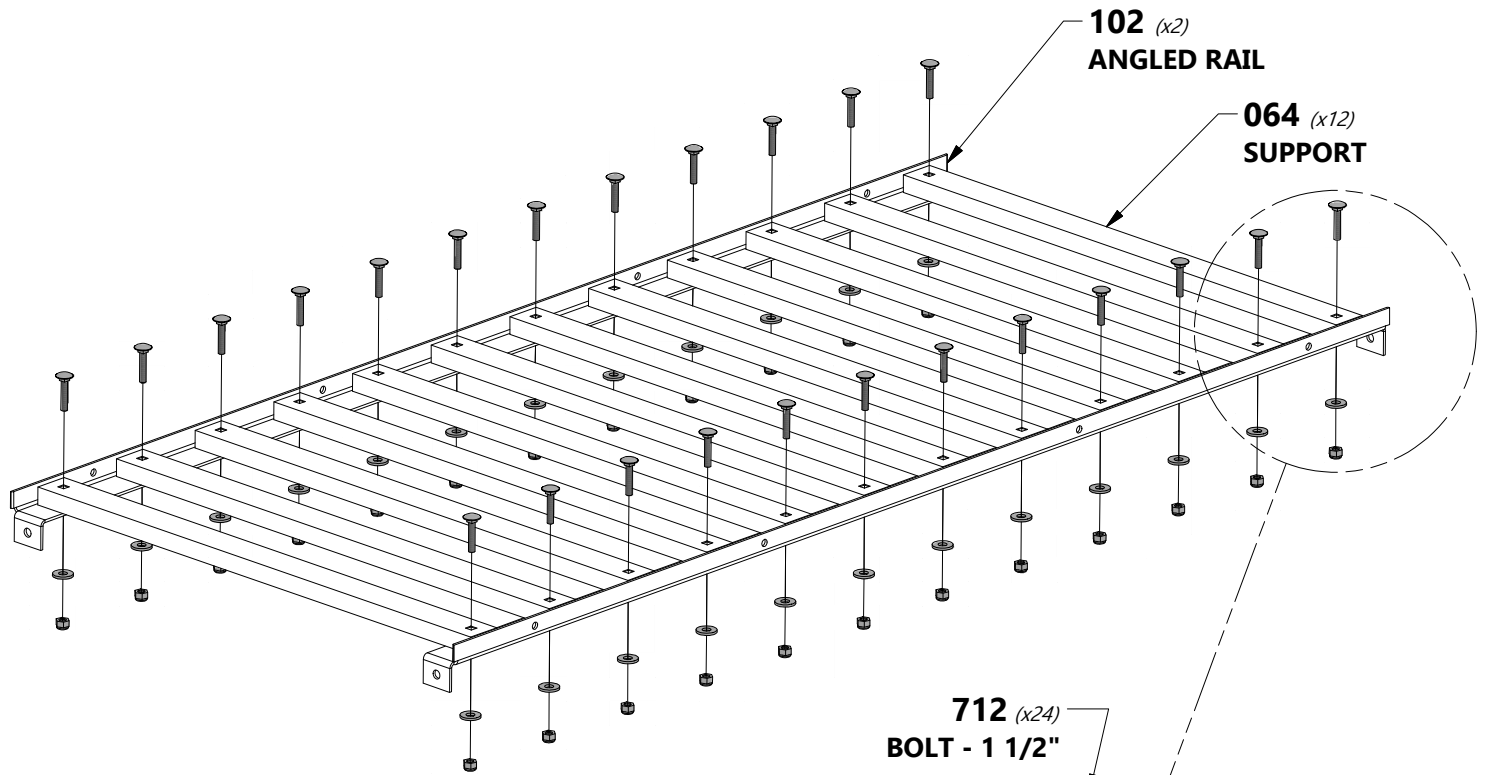

COMPLETE THIS STEP TWICE

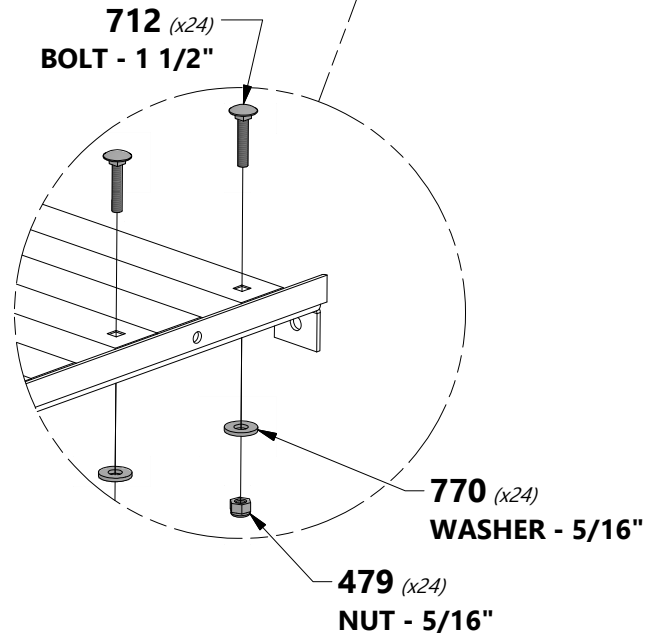

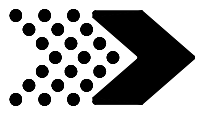

SEATING ASSEMBLY

STEP 22

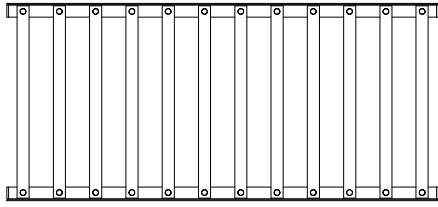

(2) SEAT SUPPORT SUBASSEMBLY



H100171 | BOLT WH BLK
(12) | 1/4x1



H100460 | LAG SCREW WH BLK
(10) | 1/4x1



1. PILOT DRILL WOOD RAILS, USING A 1/8" DRILL BIT, BEFORE INSTALL HARDWARE TO AVOID SPLITTING.

2. AFTER SEAT SUPPORT SUBASSEMBLIES ARE INSTALLED, FINISH TIGHTENING ALL THE BOLTS AND SCREWS FROM PREVIOUS STEP.

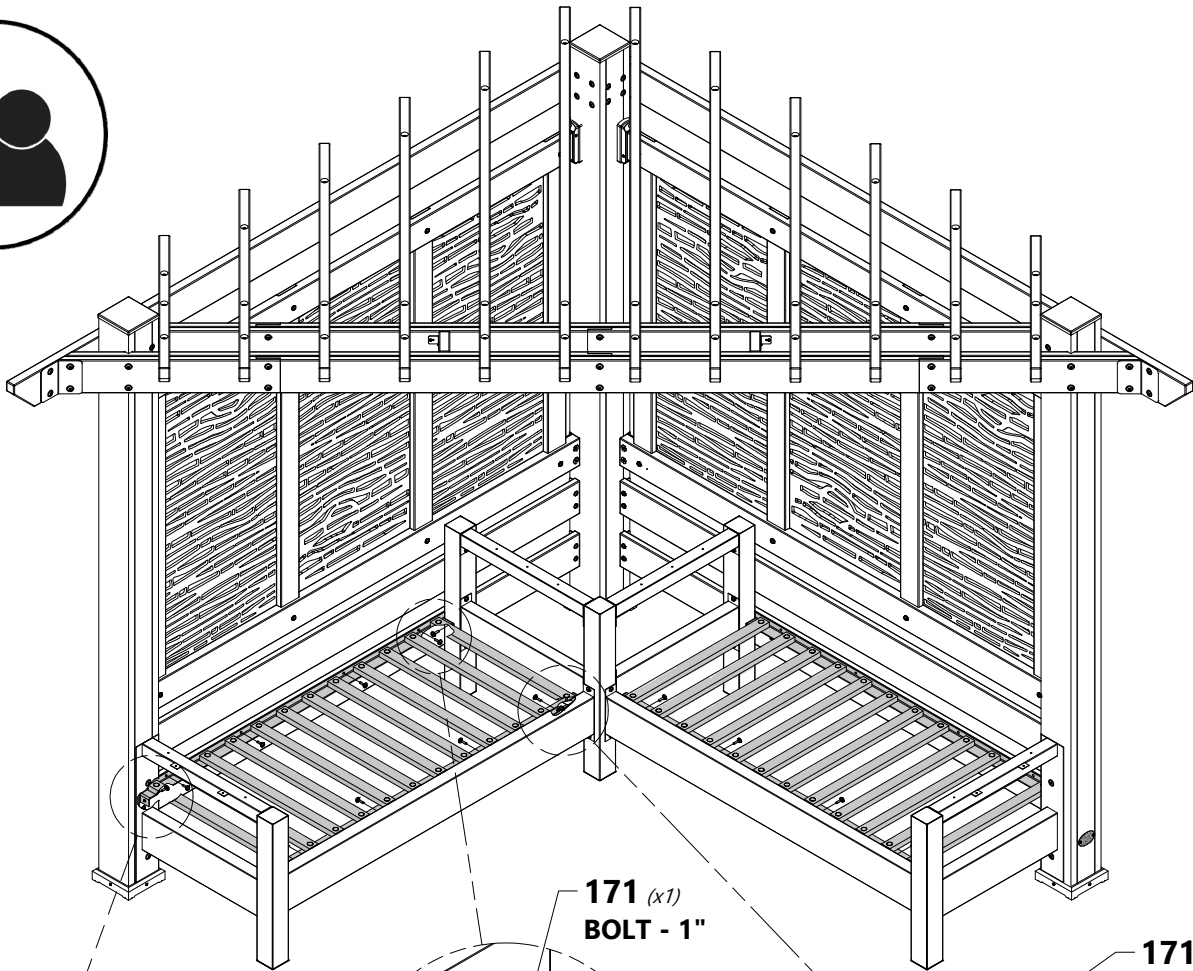

171 (x1)
BOLT - 1"

171 (x4)
BOLT - 1"
(FRONT L-BRACKET)

460 (x1)
LAG SCREW - 1"
(CORNER POST)

460 (x4)
LAG SCREW - 1"
(BACK L-BRACKET)

171 (x1)
BOLT - 1"

REPEAT FOR BOTH SEAT SUBASSEMBLIES

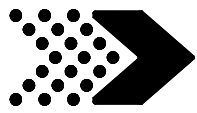

SEATING ASSEMBLY

STEP 23

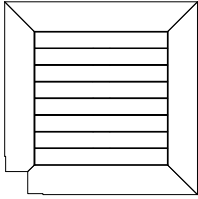

TT1 | TABLE TOP - W2A02868
(1) | 1 5/16" x 30 1/8" x 30 1/8" (34 x 765 x 765)

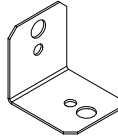

A4M00555 | 90° L-BRACKET - BLK
(2)

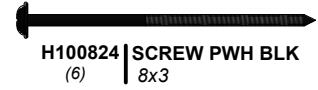

H100824 | SCREW PWH BLK
(6) | 8x3



H100202 | SCREW PWH BLK
(4) | 8x5/8

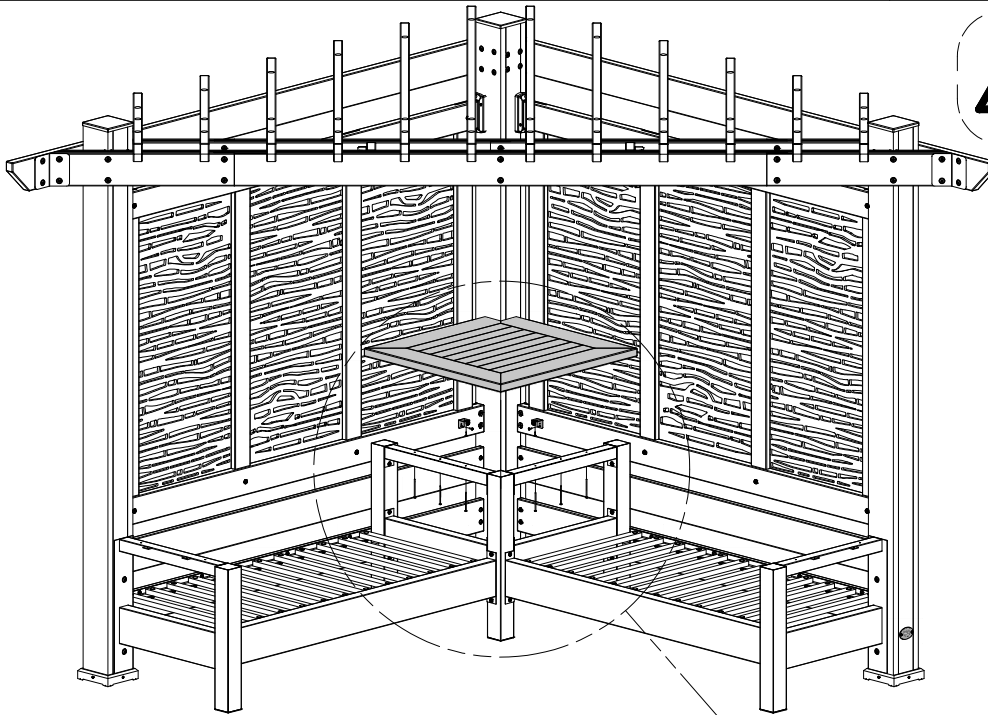

NOTE:
ATTACH REAR CORNER L-BRACKETS FIRST

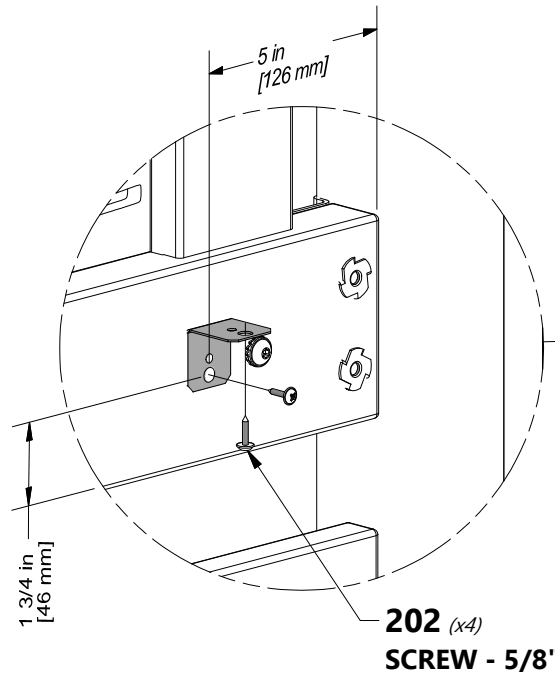

202 (x4)
SCREW - 5/8"

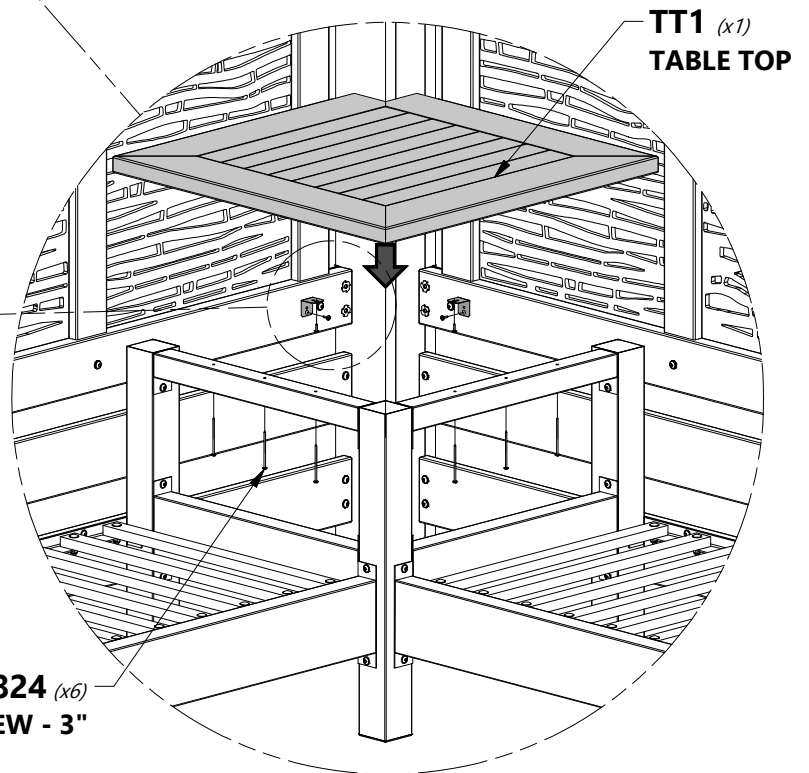

824 (x6)
SCREW - 3"

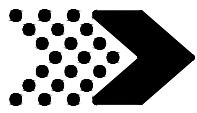

SEATING ASSEMBLY

STEP 24

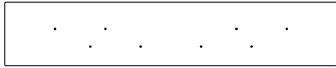

D7 | **ARM REST - W4L14844**
(2) | 1 3/8"x4 5/8"x26" (34x118x660)

← **H100824** | **SCREW PWH BLK**
(4) | 8x3

← **H100392** | **SCREW PWH BLK**
(4) | 8x3/4

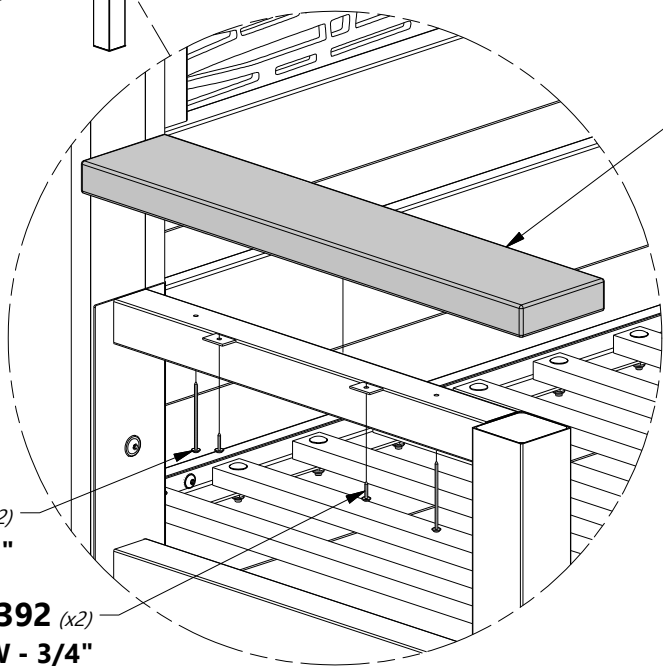
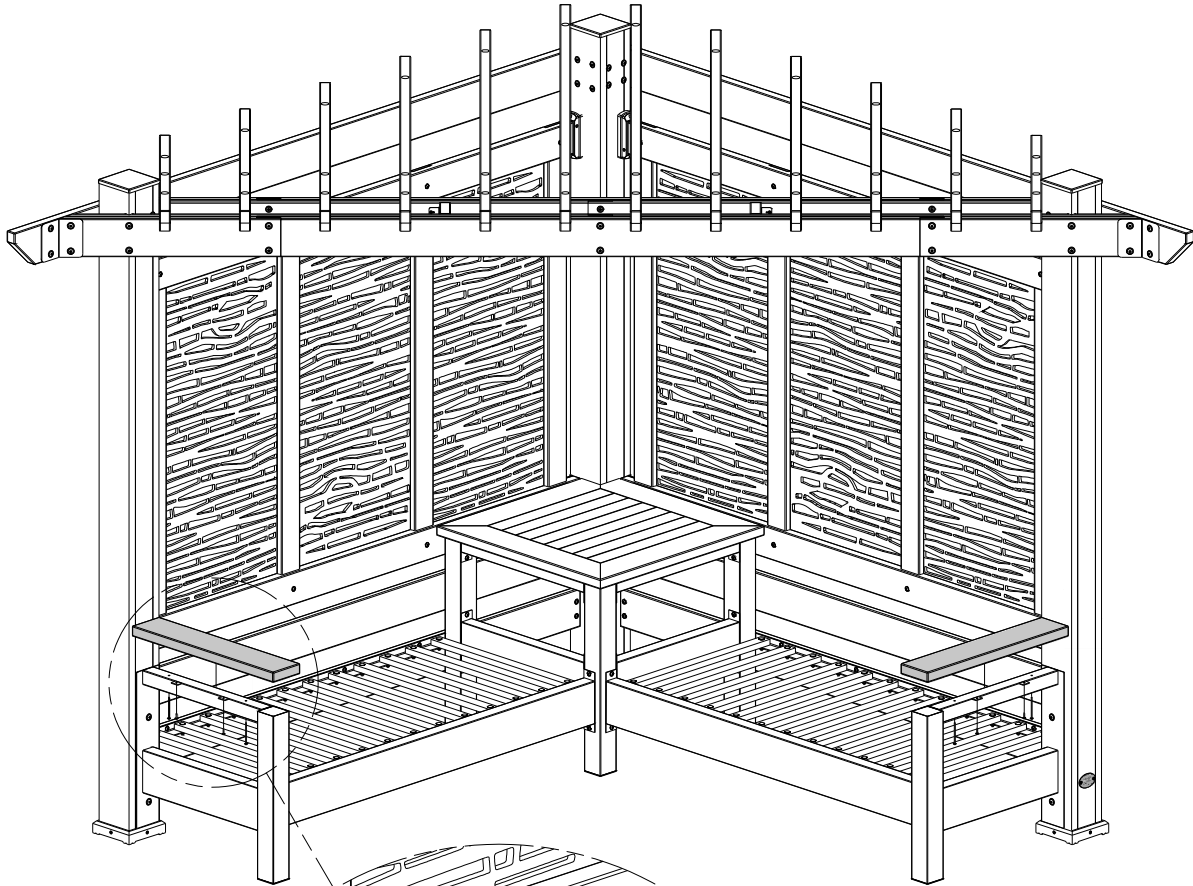

D7 (x1)
ARM REST

REPEAT FOR BOTH ARM RESTS

824 (x2)
SCREW - 3"

392 (x2)
SCREW - 3/4"

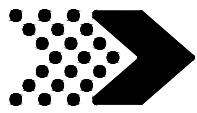

SEATING ASSEMBLY

STEP 25

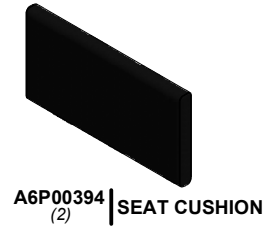
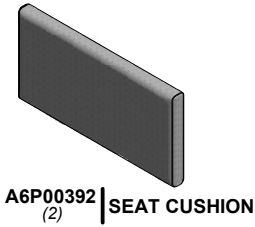
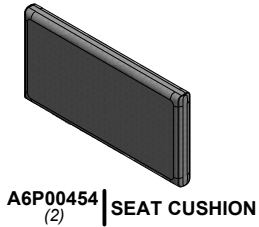

OR

OR

