

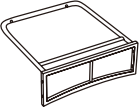











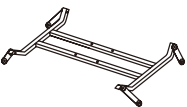
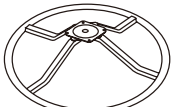

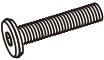
COMPONENT LIST - ARMCHAIR

Item no.	Reference Image	Description	Qty.
A2		Seat Panel	1
B2		Back Panel	1
C2		Left Armrest	1
D2		Right Armrest	1
E		Metal Stand	1
F		Metal Base	1
M		M6*30 Head Cap Screw	4
N		Washer	26
O		M6*35 Head Cap Screw	10
P		M6*45 Head Cap Screw	4

COMPONENT LIST - ARMCHAIR

Item no.	Reference Image	Description	Qty.
Q		Nut	8
R		Allen Key	1
S		Plastic Washer	4
T		Cap	4
V		Spanner	1
I		Seat Cushion	1
J		Pillow	1

01

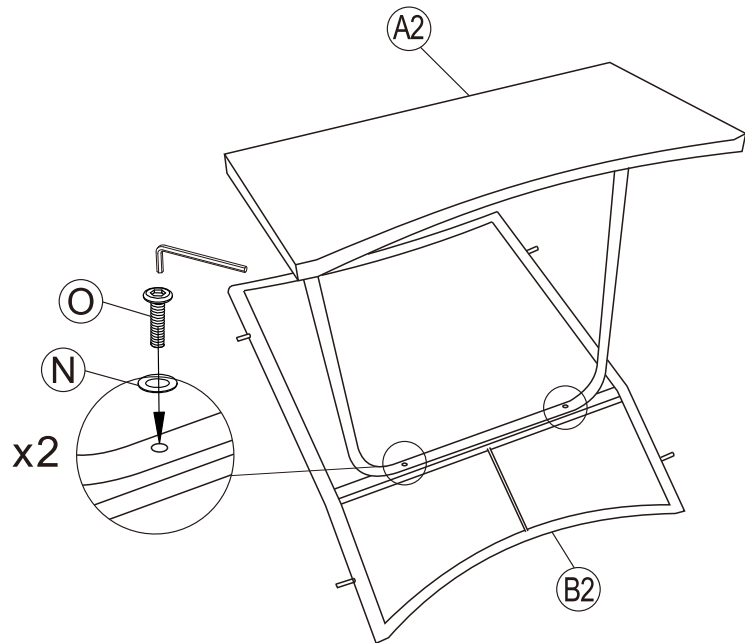
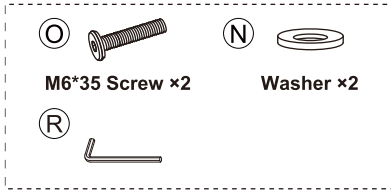

assembly Sofa assel:

As shown in the figure, place the chair backrest A2 and seat frame B2 side, so that the holes in the shown position are aligned, put the gasket N on the screw O, firmly assemble the backrest A2 and seat frame B2, and tighten with the hex tool.

02

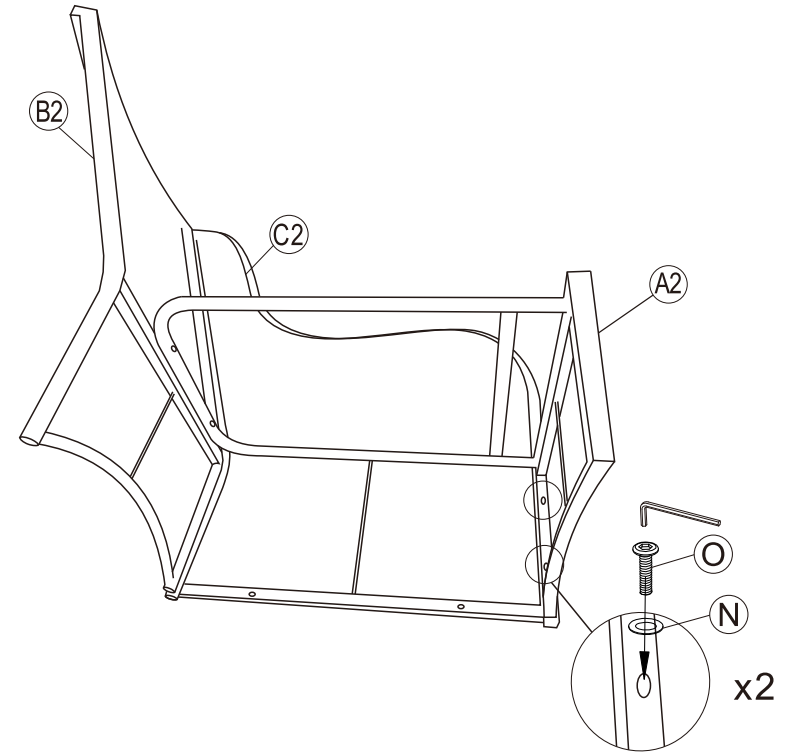
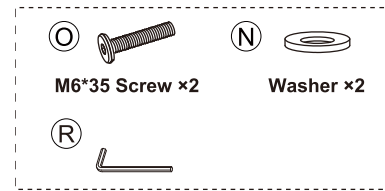

As shown in the figure, put the left armrest frame C2 flat on a clean plane, align the screw hole on the assembly in the previous step with the screw hole on the left armrest frame C2, put a gasket on the screw, combine the armrest with the seat frame and the backrest, and tighten the screw with the hex tool.

Note: Carefully compare the picture, the screw models used in different assembly parts are different, please pay attention to distinguish.

03

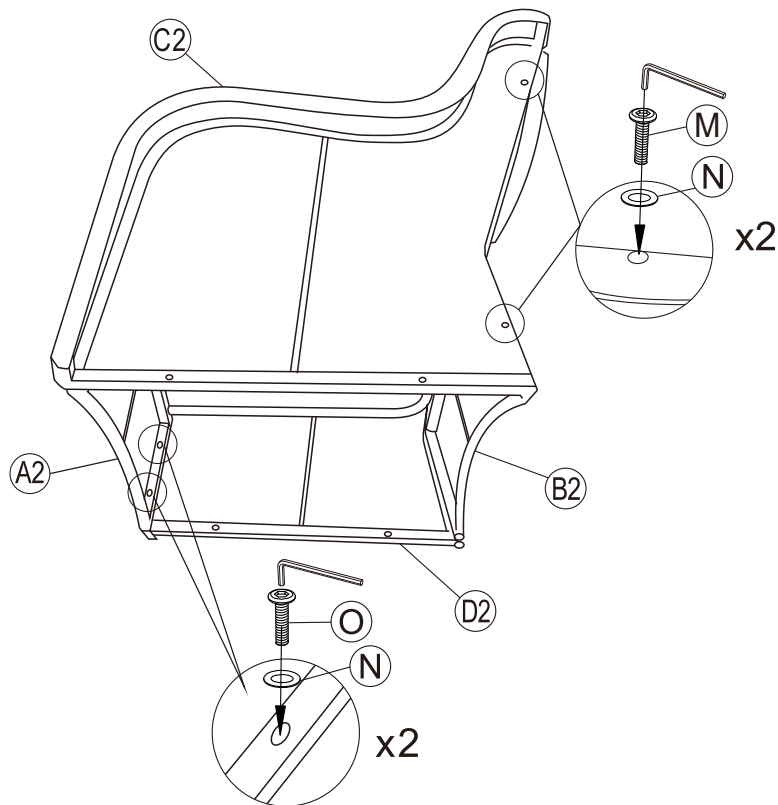
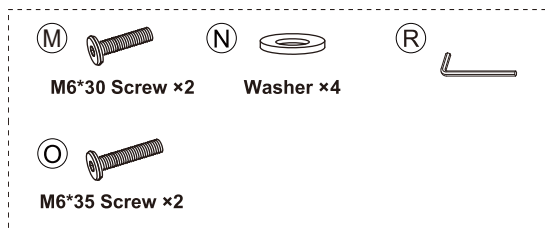

04

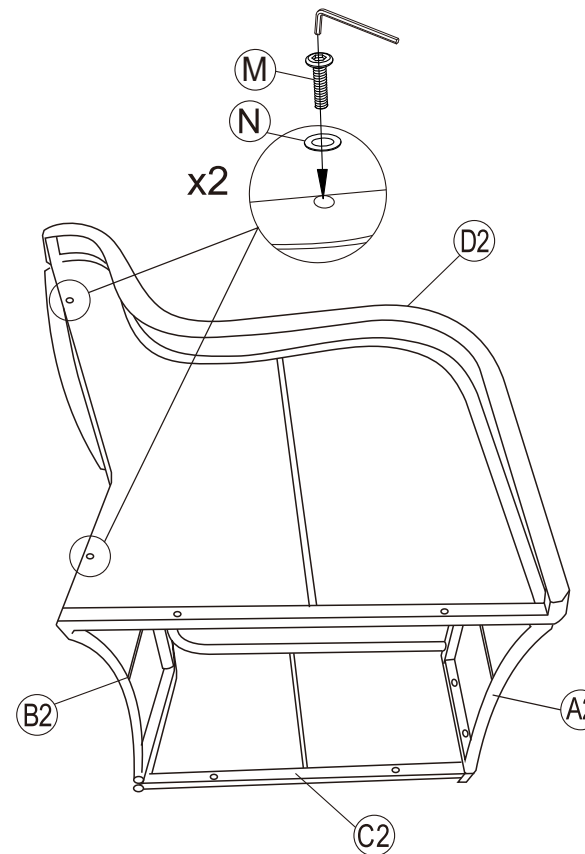
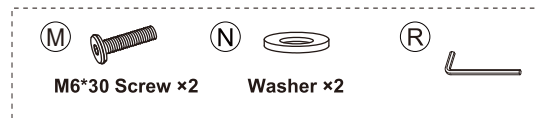

As shown in the figure, place the right armrest D2 on a clean surface, align the screw holes on the right armrest D2 from the assembly in the previous step with the screw holes on the right armrest D2, put gaskets on the screws, combine the armrest with the seat frame and the backrest, and tighten the screws with the hex tool.

Note: Carefully compare the picture, the screw models used in different assembly parts are different, please pay attention to distinguish.

05

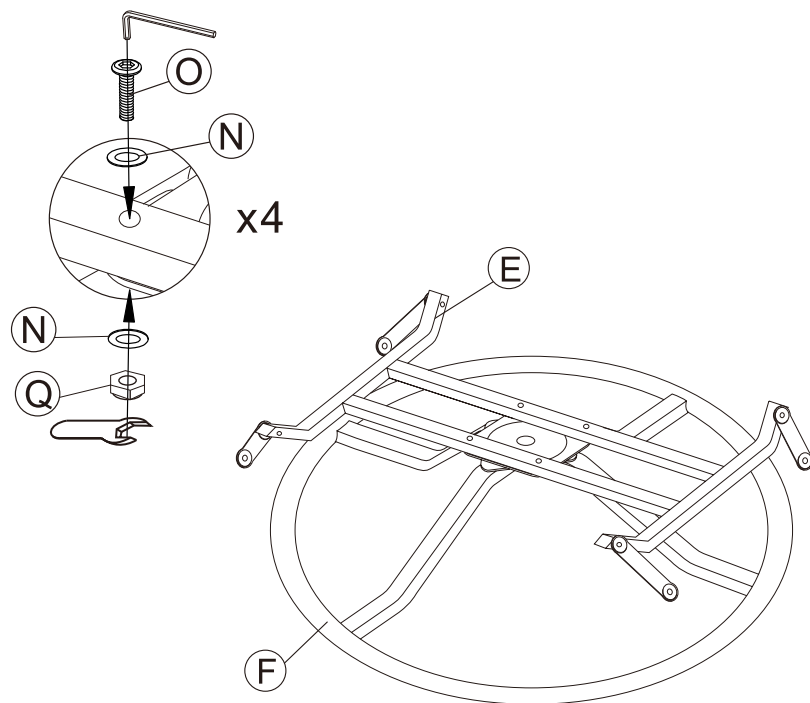
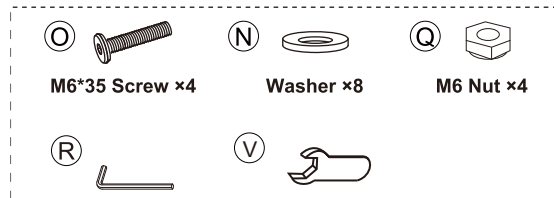

Place base F flat on the ground, put gasket N on screw O, fix support frame E on base F, then put gasket N, and lock screw O and nut Q with hex tools R and V.

06

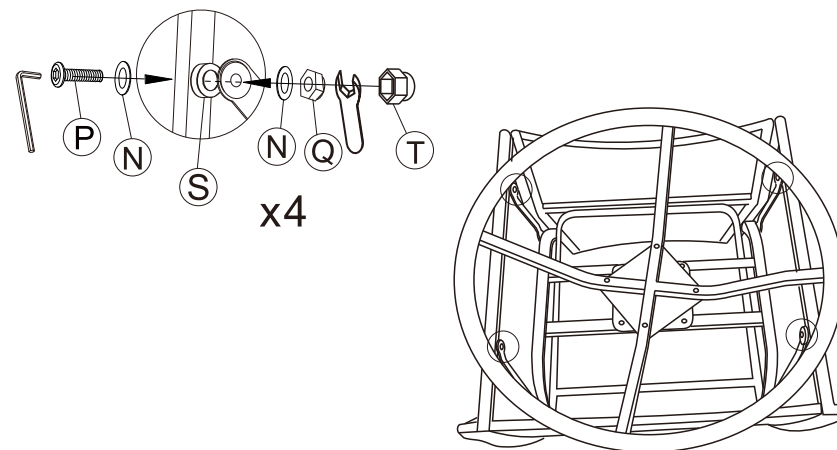
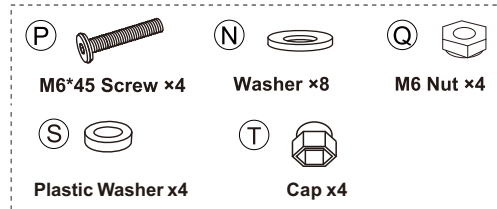

07

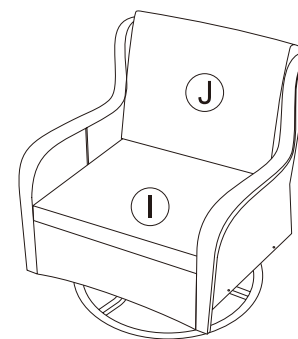

Place the bottom of the sofa assembled in step 4 upward on a clean plane, put gasket N over the screw P in the reserved hole at the bottom edge of the figure, assemble the four supporting feet of the metal support frame E, put on the plastic cushion S, gasket N, nut Q in order, and tighten the screw with the hex tool R and V. When assembled, the support frame is on the inside of the sofa.