









ASSEMBLY INSTRUCTION

POTTER TWIN BED

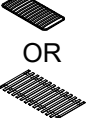
Components

NO.	PICTURE	DESCRIPTION	QTY.
A		Headboard	1
B		Footboard	1
C		Side rail	2
D		Foot	4
E	 OR 	Slats set	1

Hardware

NO.	PICTURE	DESCRIPTION	SPEC.	QTY.
1		Stud Bolt	M8X100mm	8
2		Nut	M8X13X13mm	8
3		Lock Washer	M8X13X2mm	8
4		Special Washer	M8X15X40mm	8
5		Wrench	M8X25X100mm	1
6		Cap	Ø60mm	8

Assembly steps

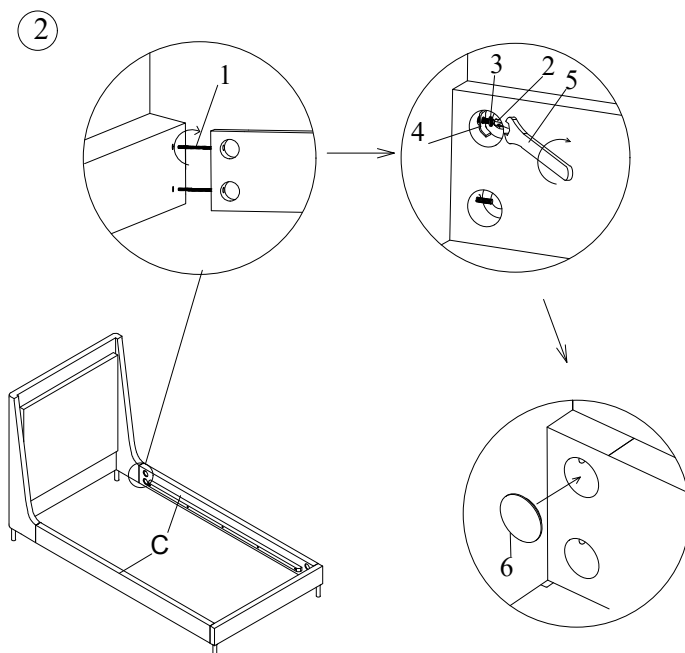
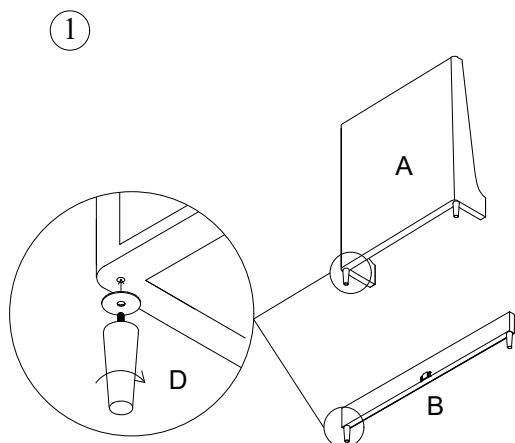

ASSEMBLY INSTRUCTION

POTTER TWIN BED

3

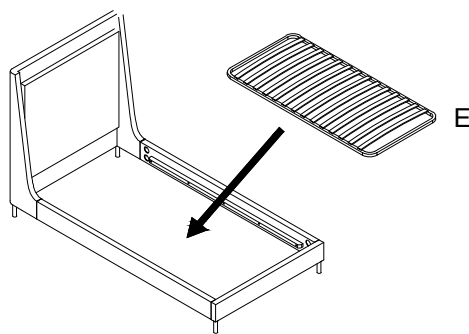

OR

