

QUEEN SIZE BED

ASSEMBLY INSTRUCTIONS



ASSEMBLY INSTRUCTIONS

ASSEMBLY TIPS:

1. Remove Hardware from box and sort by size.
2. Please check to see that all hardware and parts are present prior to start of assembly.
3. Please follow attached instructions in the same sequence as numbered to assure fast & easy assembly.











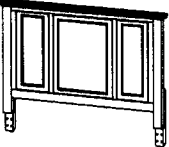

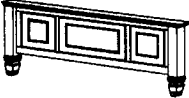

Warning !

1. Don't attempt to repair or modify parts that are broken or defective. Please contact the store immediately.
2. This product is for home use only and not intended for commercial establishment.

PARTS IDENTIFICATION

HARDWARE IDENTIFICATION

A		HEADBOARD PANEL 1 PC	1		ALLEN WRENCH	1 PC
B1		LEFT BED RAIL 1 PC	2		BOLT	8 PCS
B2		RIGHT BED RAIL 1 PC	3		LOCK WASHER	8 PCS
C		FOOTBOARD 1 PC	4		FLAT WASHER	8 PCS
D1		LEFT HEADBOARD LEG 1 PC	5		FLAT HEAD SCREW	8 PCS
D2		RIGHT HEADBOARD LEG 1 PC				
E		BED SLAT 4 PCS				
F		BED SLAT SUPPORT WITH LEVELER 4 PCS				

NOTE :ALL HARDWARE WAS PACKED IN A BAG AND PUT IN HEADBOARD BOX (BOX 1)

ASSEMBLY INSTRUCTIONS

STEP 1

Align and fasten headboard legs to headboard panel using bolt, lock washer and flat washer and tighten with Allen wrench.

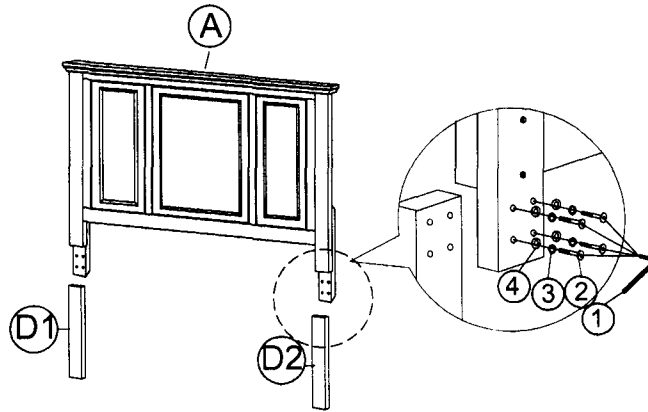

STEP 2

Align and hook the bed rail to headboard and footboard.

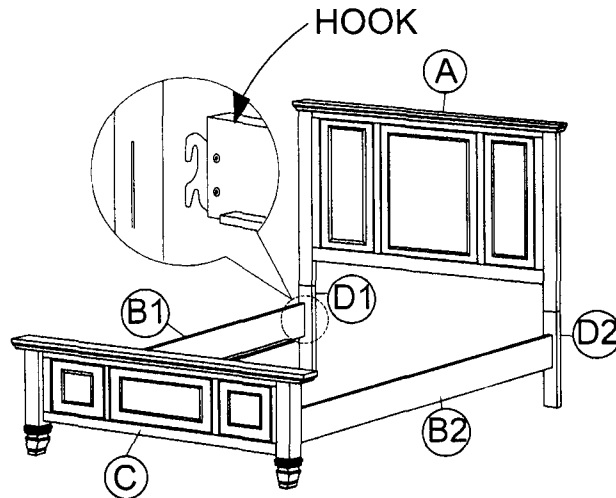

STEP 3

Align and screw in bed slat support to bed slat. Adjust leveler to touch floor. Align and fasten bed slat to bed rails using screws and tighten with screw driver(not included).

