











# Assembly Instructions

**Caution: You must read this before you proceed**

## Care & Maintenance

-  ● Not for commercial use. For residential use only.
-  ● Furniture may scratch floors. We recommend using furniture pads to protect your floors.
-  ● Do not put hot items directly on furniture surface.
-  ● Do not clean furniture with harsh cleansers or polish.
-  ● Do not place furniture under direct sunlight.
-  ● Do not place furniture near heating or cooling vents.
-  ● Do not write on furniture without a padded barrier to protect the surface.
-  ● Do not place furniture outside . For indoor use only.
-  ● Stains may be removed with mild soap solution and damp cloth.
-  ● Children should not climb or jump on the furniture.
-  ● Dust and pick-up spills using a clean, non-colored, lint-free cloth.



Please look in the magic tape pouch for hardware packs and legs.

Sets often ship in multiple boxes and may arrive a day or two apart.

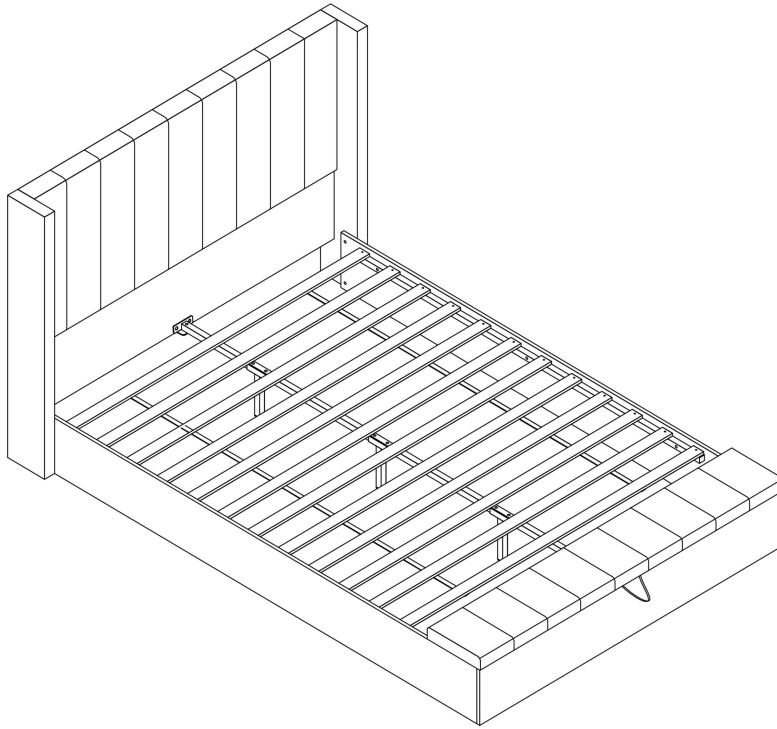
# Bed



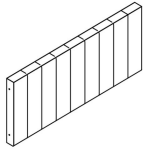

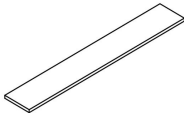
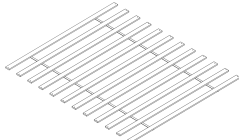



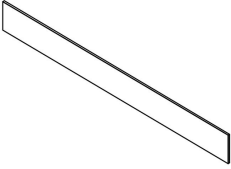
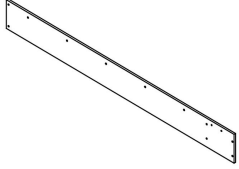
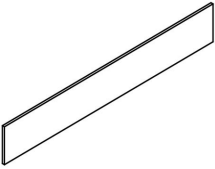
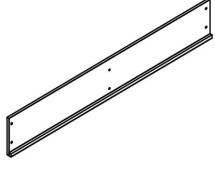
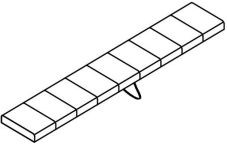
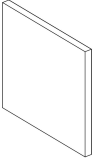
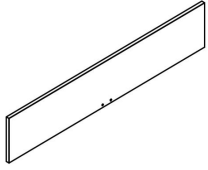
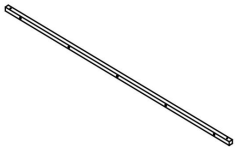
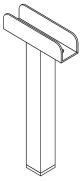
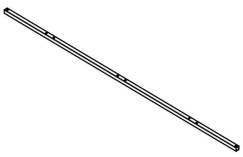

## Part List

Label	Picture	Description	QTY
A		Head board	1
B		Side head board	1
C		Side head board	1
I		Storage bench base board	1
O		Slats	1

## Part List

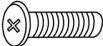
Label	Picture	Description	QTY
D		Side rail	1
E		Side rail	1
F		Foot board	1
G		Storage bench back board	1
H		Storage bench cover	1
J		Storage bench middle board	1
K		Base headboard	1
L		Side rails support bar	2
M		Middle support leg	3
N		Center support bar	1

# Hardware

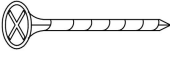
Label	Picture	Description	QTY
①		Allen Wrench(M5)	1
②		Bolts (M8x40mm)	26
③		Hinge	4
④		Bolts (M8x16mm)	28
⑤		Bolts (M6x15mm)	4
⑥		Nails (M4X30mm)	24
⑦		Center support bar fittings	2
⑧		Washer	8
⑨		Nails (M5X30mm)	2

# Assembly Preparation

Before Beginning Assembly:

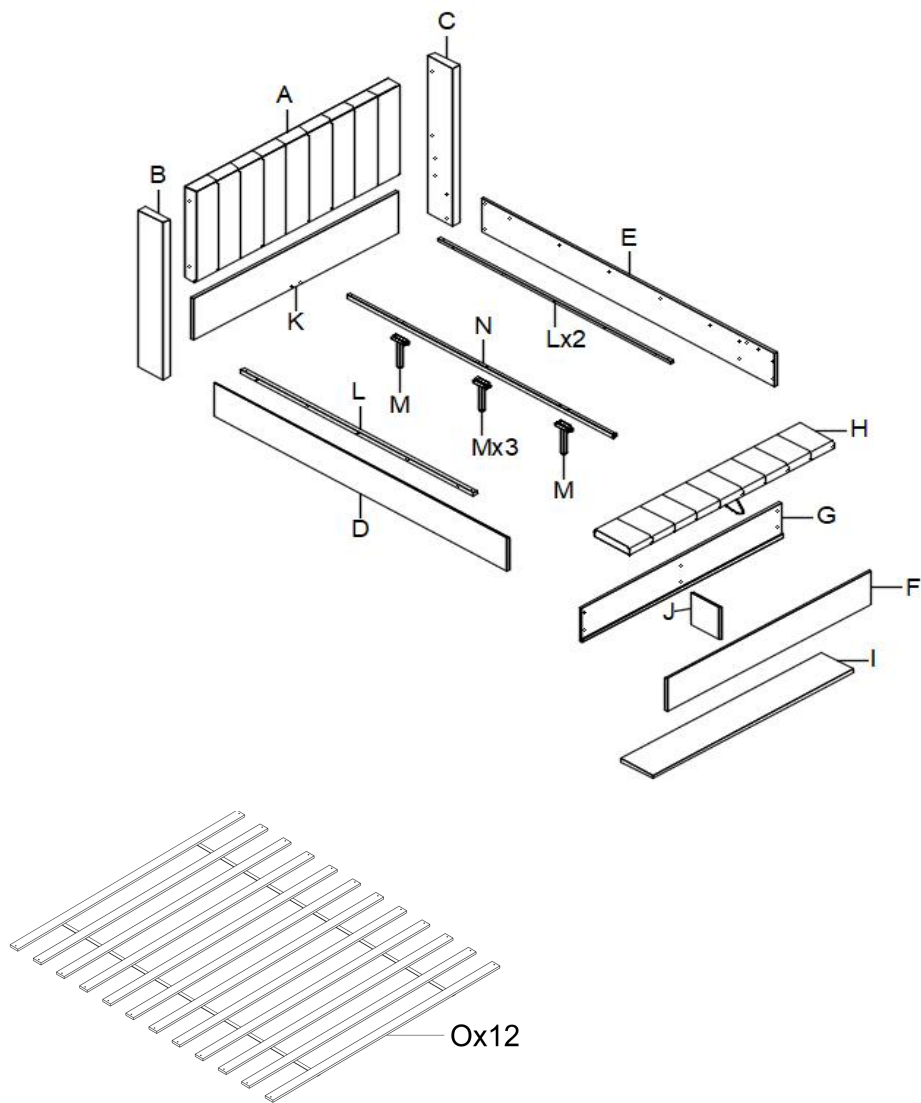

- |   |     |   |     |
|---|-----|---|-----|
| ① | x1  | ⑥ | x24 |
| ② | x26 | ⑦ | x2  |
| ③ | x4  | ⑧ | x8  |
| ④ | x28 | ⑨ | x2  |
| ⑤ | x4  |   |     |

- Read instructions, cover to cover-
- Have 2 adults on hand for assembly-
- Do not assemble on flooring or carpet-
- Assemble on a clean non-marring surface (packing foam)-
- Save all packaging until finished-

# Assembly Steps

## OVERVIEW

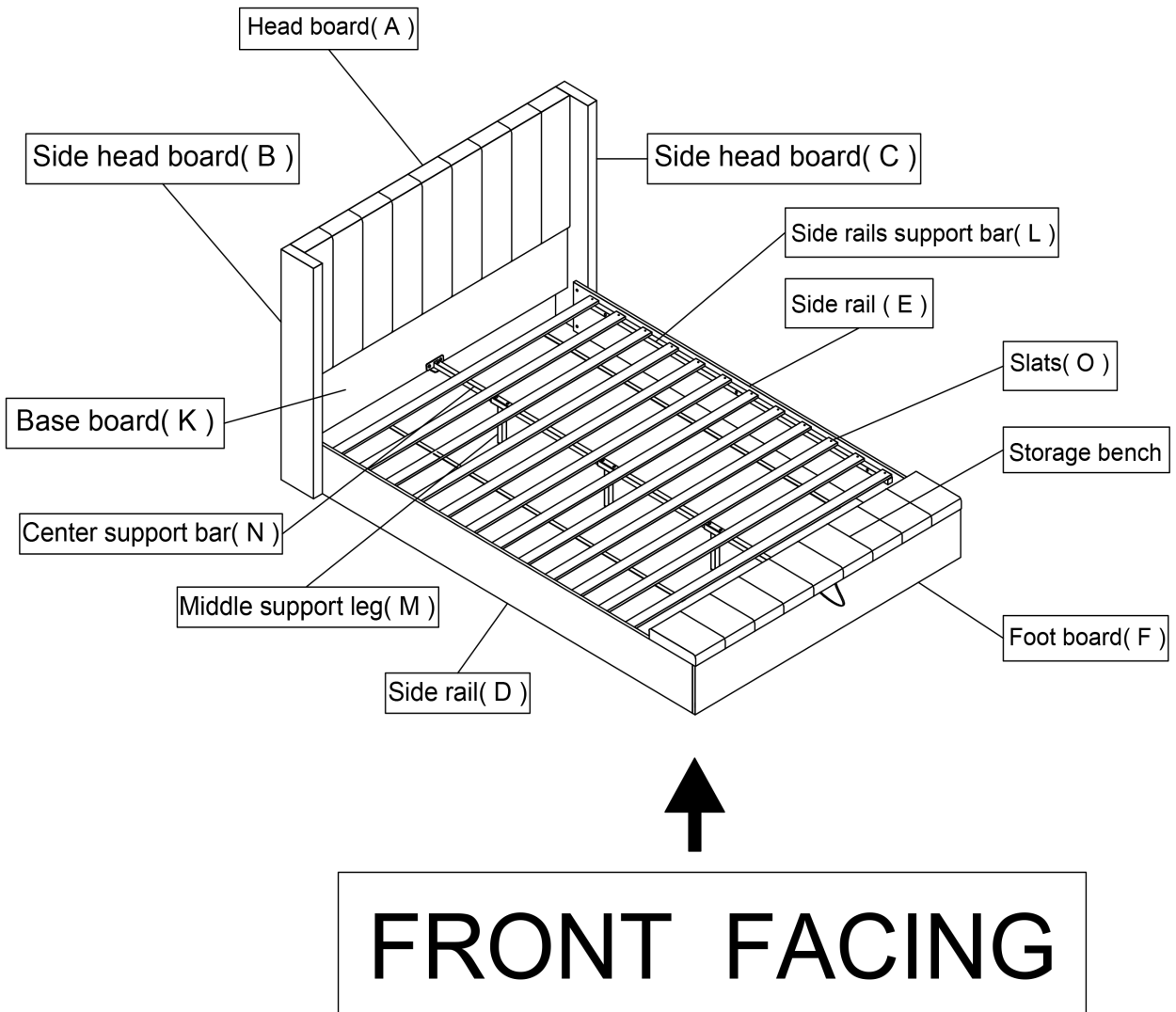



This Bed have multiple parts and may require up to 60 minutes to assemble. To give you an overview of the Bed parts, the above picture is to help you put the various parts into perspective. Please read through the instructions below to familiarise yourself with the parts and steps before assembly.

**Note: It is recommended that you have an adult partner to assist during the entire assembly process.**

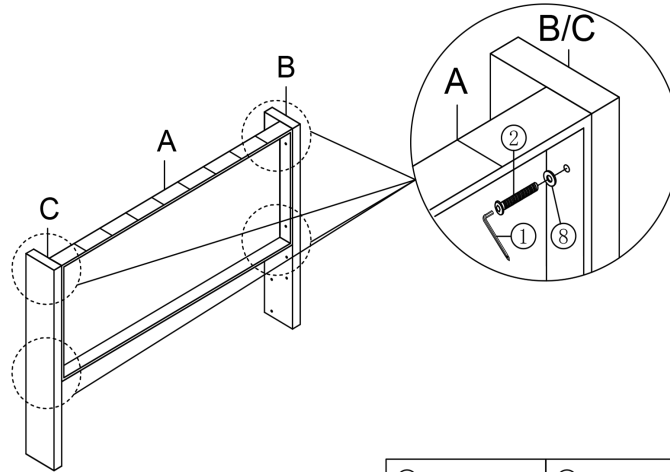
**Step 1**





① Allen Wrench 	② Bolts x 4 M8x40mm 	⑧ Washer x 4 
---	---	---

Fix the Head board A to the Side head board B and Side head board C with Bolts ② and Washer ⑧ by using Allen Wrench ①.

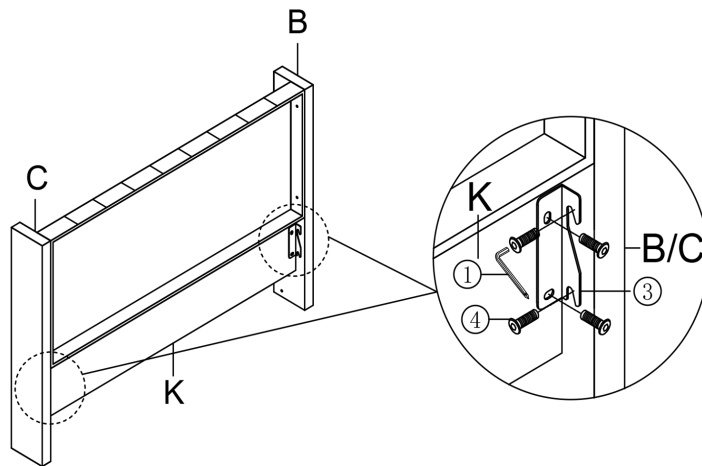
**Step 2**



① Allen Wrench 	③ Hinge x 2 	④ Bolts x 8 M8x16mm 
--	--	---

Fix the Base board K to the Side head board B and Side head board C with Bolts ④ and Hinge ③ by using Allen Wrench ①.

**Step 3 x 2**

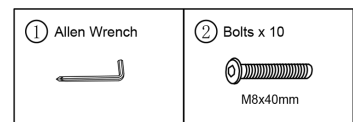
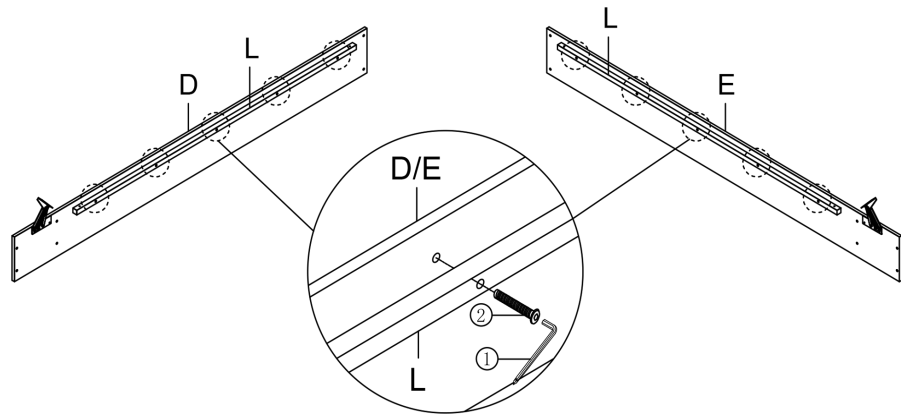

Fix the Side rails support bar L to the Side rail D and Side rail E with Bolts ② by using Allen Wrench ①.

**Step 4 x 2**

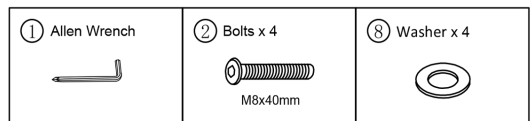
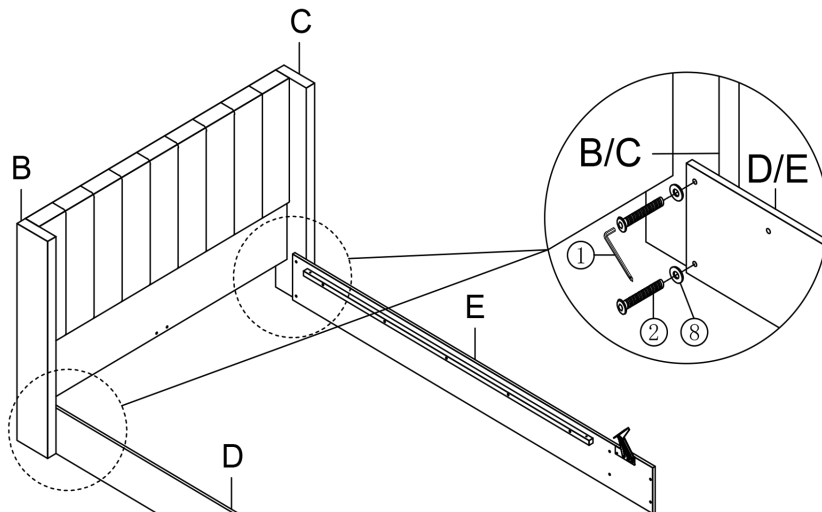

Fix the Side rail D and Side rail E to the Side head board B and Side head board C with Bolts ② and Washer ⑧ by using Allen Wrench ①.

**Step 5**

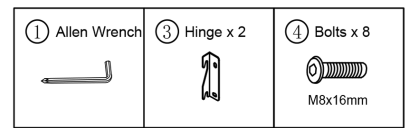
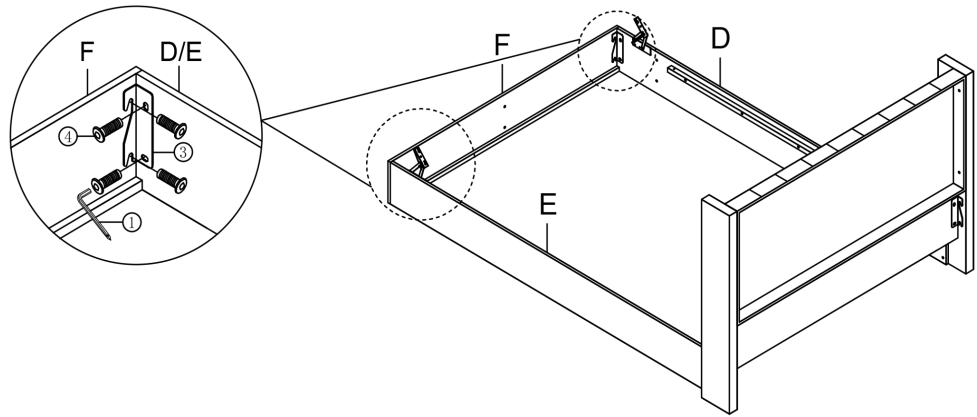

Fix the Foot board F to the Side rail D and Side rail E with Bolts ④ and Hinge ③ by using Allen Wrench ①.

**Step 6**

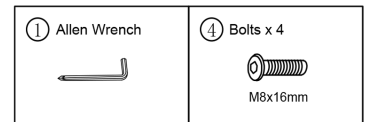
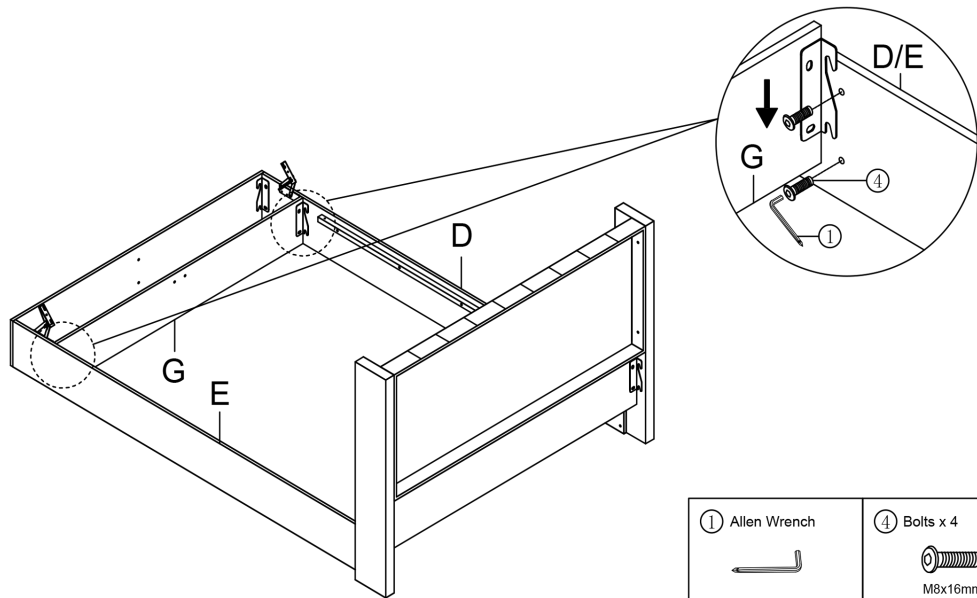

Fix the Storage bench back board G to Side rail D and Side rail E with Bolts ④ by using Allen Wrench ①.

**Step 7**

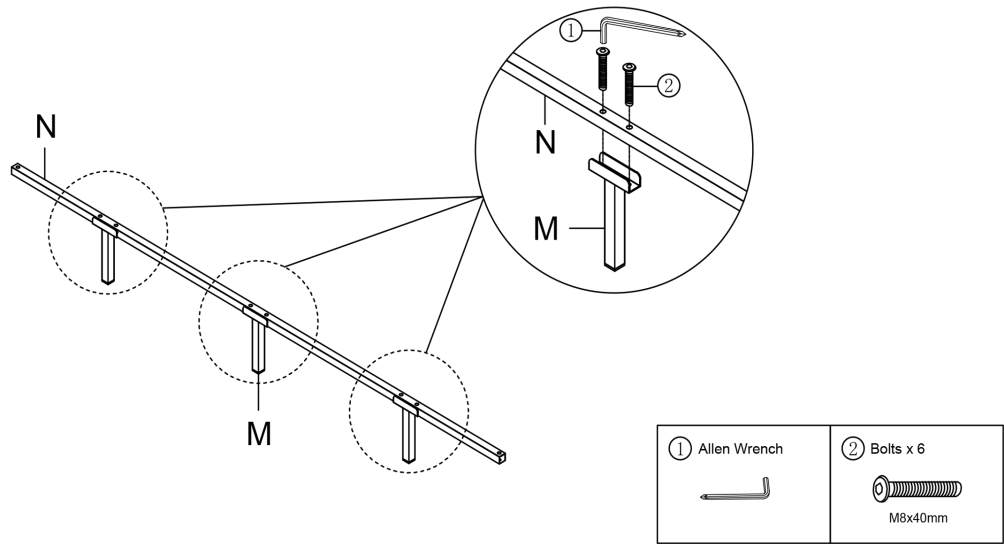

Fix the Middle support leg M to the Center support bar N with Bolts ② by using Allen Wrench A.

**Step 8**

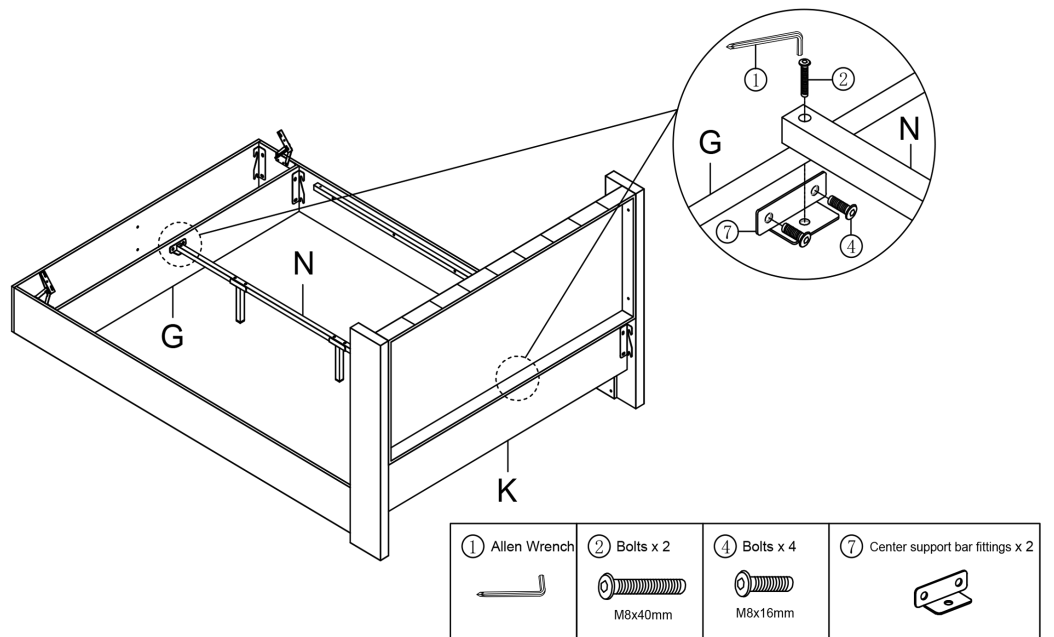

Fix the Center support bar N to the Storage bench back board G and Base board K with Bolts ② and Bolts ④ and Center support bar fittings ⑦ by using Allen Wrench ①.

**Step 9**

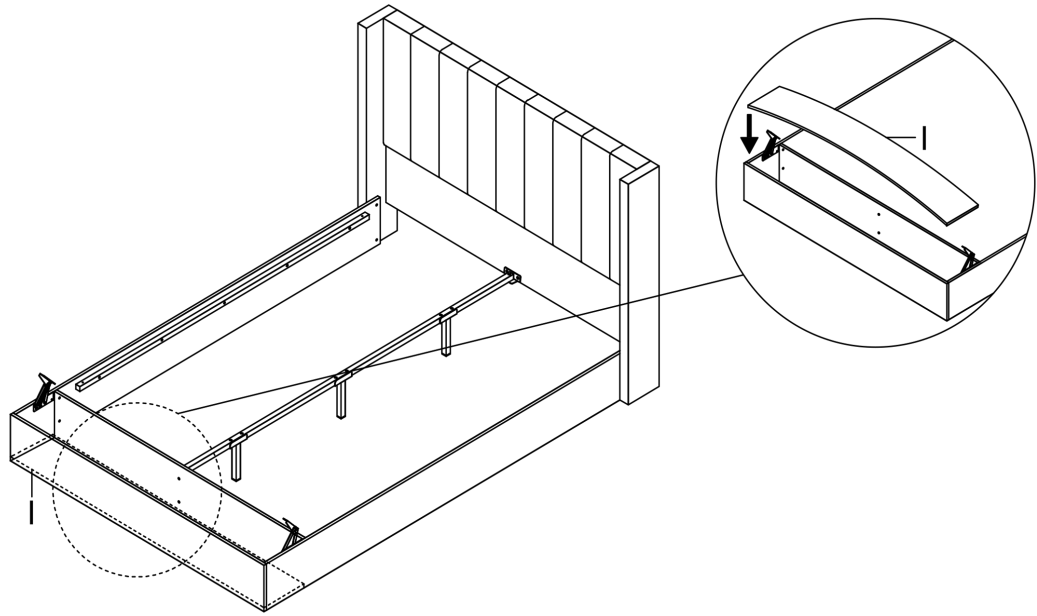

Place the Storage bench base board I into the Storage bench.

**Step 10**

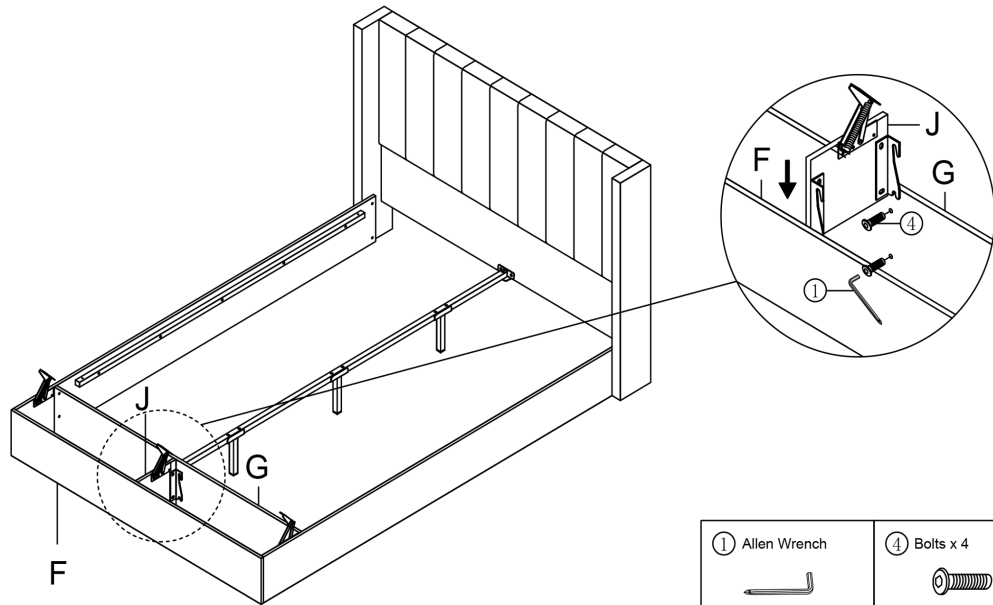

Fix the Storage bench middle board J to the Foot board F and Storage bench back board G with Bolts ④ by using Allen Wrench ①.

### Step 11

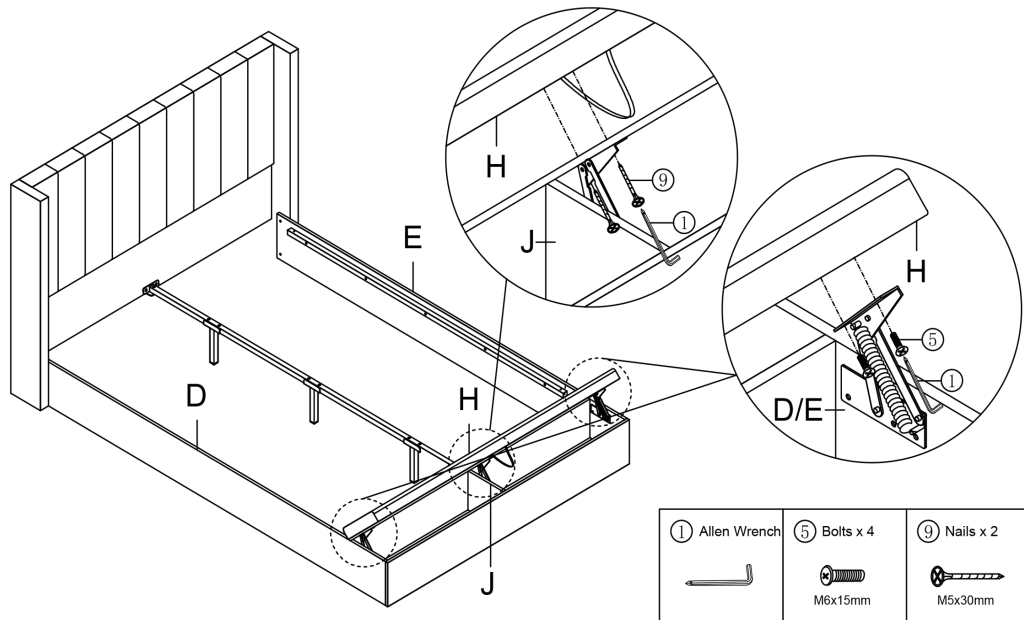

Fix the Storage bench cover H to the Side rail D and Side rail E with Bolts ⑤ by using Allen Wrench ① or Electricdrill.

Fix the Storage bench cover H to the Storage bench middle board J with Nails ⑨ by using Allen Wrench ① or Electricdrill.

### Step 12

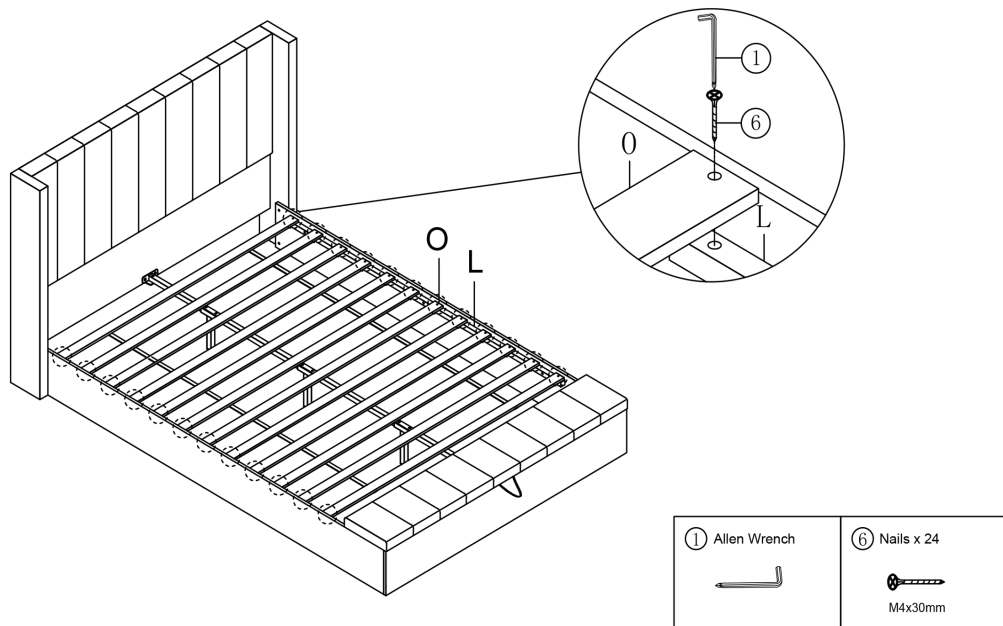

Fix the Slats O to the Side rails support bar L with Nails ⑥ by using Allen Wrench ①.

Step 13

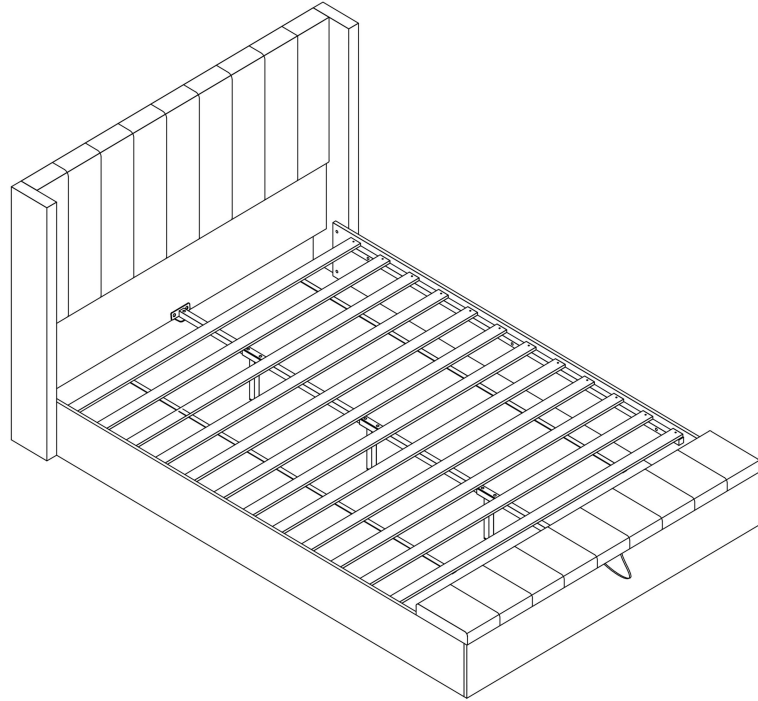

Your Bed is ready for use.  
This Bed can only be used on a flat, level surface.