

Chicken Coop

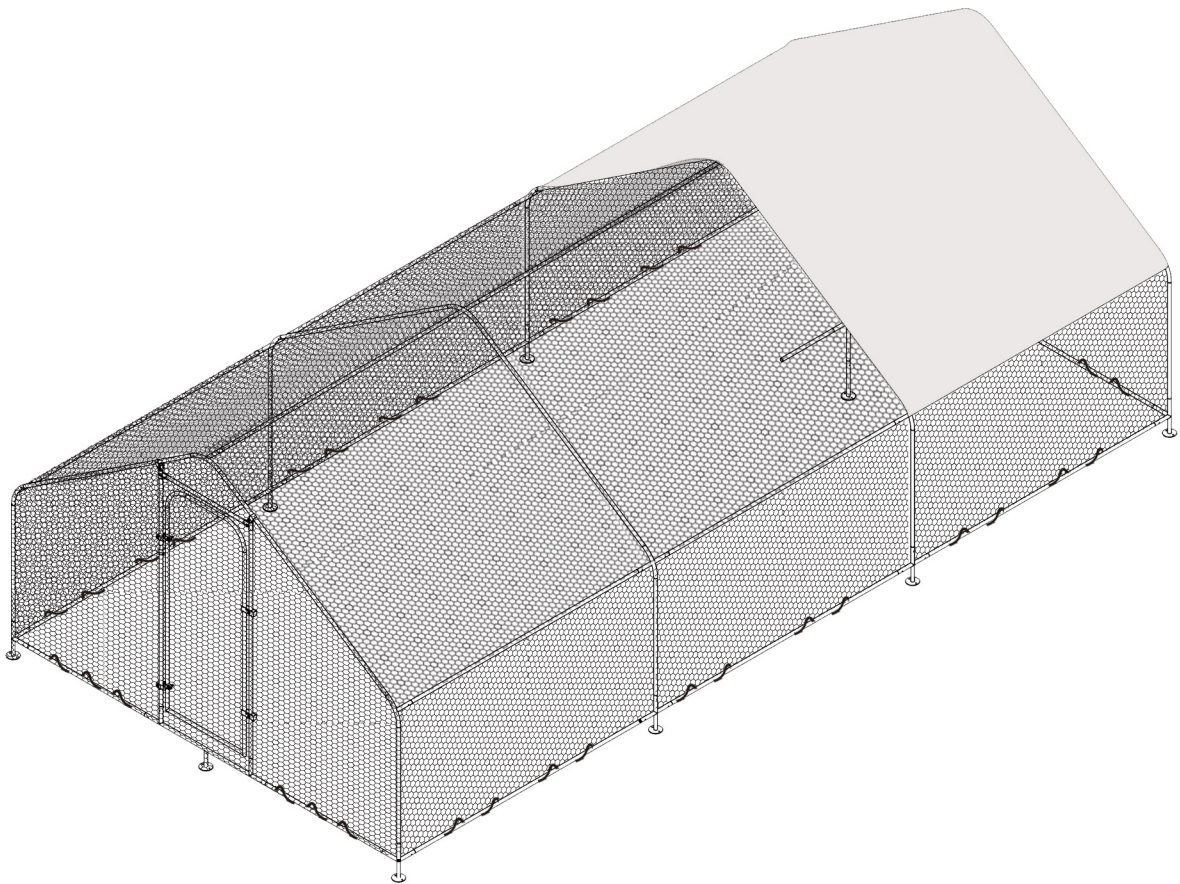

Thank you for shopping from us!

In order to enable you to better install or use this product, please carefully read the precautions and detailed functional operation instructions mentioned in this manual before using this product formally.











Hope you will have a good experience!

Assembly Guide











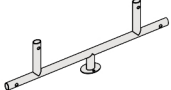





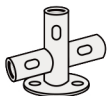





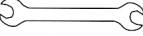
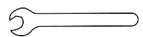

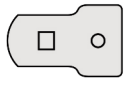

This assembly guide includes the Part List, Installation Steps and Warning Tips.

The item may be shipped into shipped in two boxes to facilitate transportation, and please understand that sometimes the packages may not arrive at the same time. Please check your package once you receive it. If any questions or issues with your item, please email us

Parts list A

 1 15 pcs 73.8 inch pipe	 7 1 pc 72.44 inch pipe
 9 1 pc 72.44 inch pipe	 5 1 pc 66.5 inch pipe
 2 8 pcs 62.4 inch pipe	 B 2 pcs 57 inch pipe
 8 2 pcs 53.9 inch pipe	hexagonal wire netting  1 pc SIZE: 1456.69"*59.1"
 4 2 pcs 41.73 inch pipe	 10 1 pc 66.5 inch pipe

Parts list B

Q 1pc Roof 	G 1 pc 	E 4 pcs 	 1 pc V P 4 pcs 	1 pc C 19.49 inch pipe  1 pc 6 23.62 inch pipe 
F 5 pcs 	D 5 pcs  H 6 pcs 	X 1 pc 	3 8 pcs 38.18 inch pipe 	A 1 pc 23.62 inch pipe 
K 1 pc 	L1 M14 1pc  L2 M12 1pc 	J 1 pc 	O 5 pcs 	R 22 pcs  L3 
18 pcs T  280 pcs S 	I 2 pcs 	U 2 pcs  N 1pc Y 1pc  	W 2pcs M8  Z 4pcs M10 	M 2pcs  L 2pcs M6 

Installation Steps

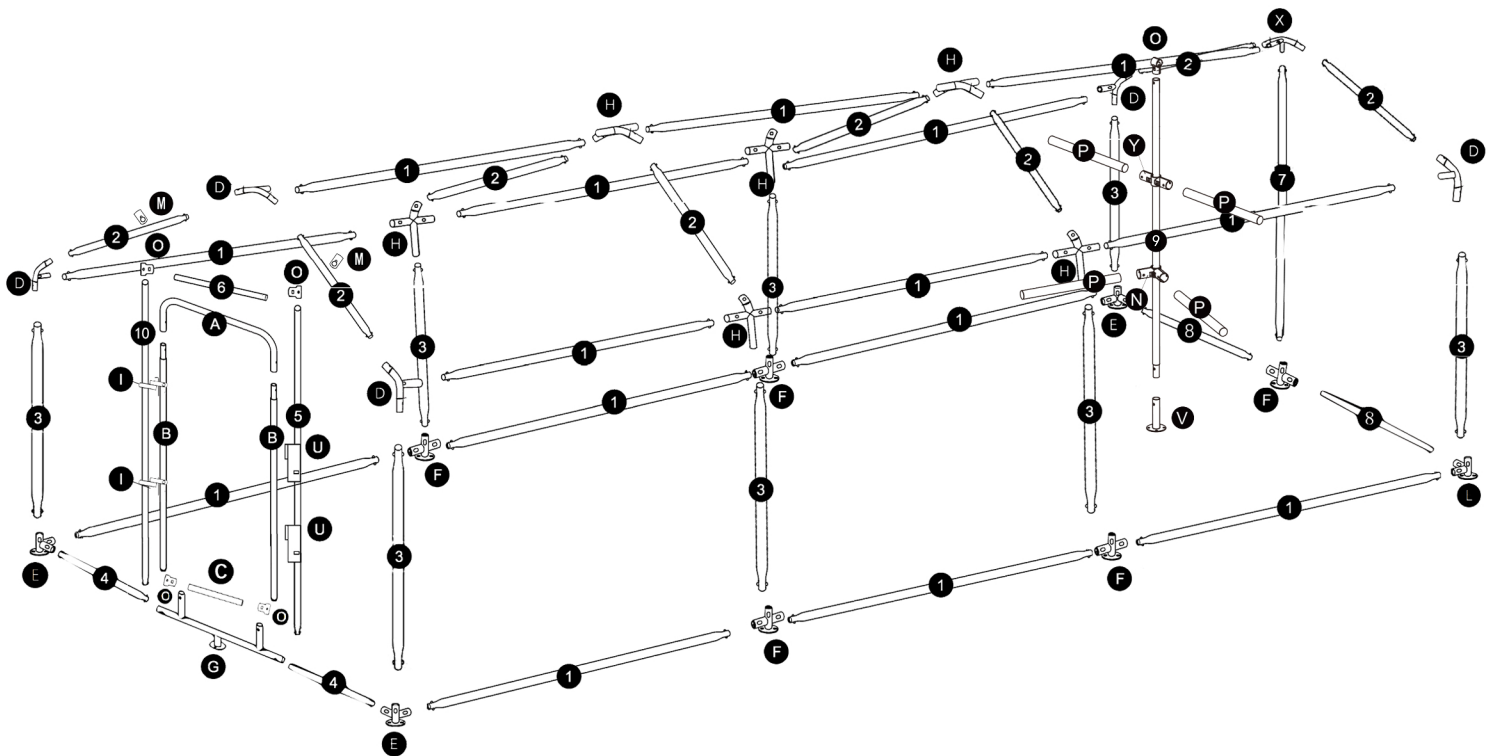







Checking

Check if there is any part missing or damaged.

Ensure the parts and quantities in parcel are accordance with Part List. If any mistakes, please kindly contact us through the purchase platform.

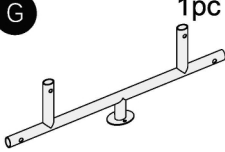
Assembly

Step 1

E  4pcs	F  5pcs	G  1pc	 1 6pcs
			 8 2pcs
			 4 2pcs

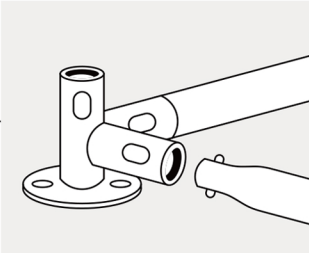

Put the E and # 4 together

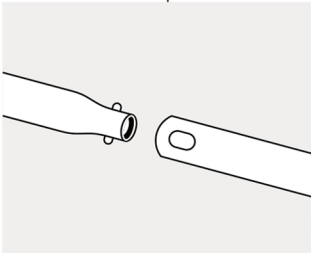
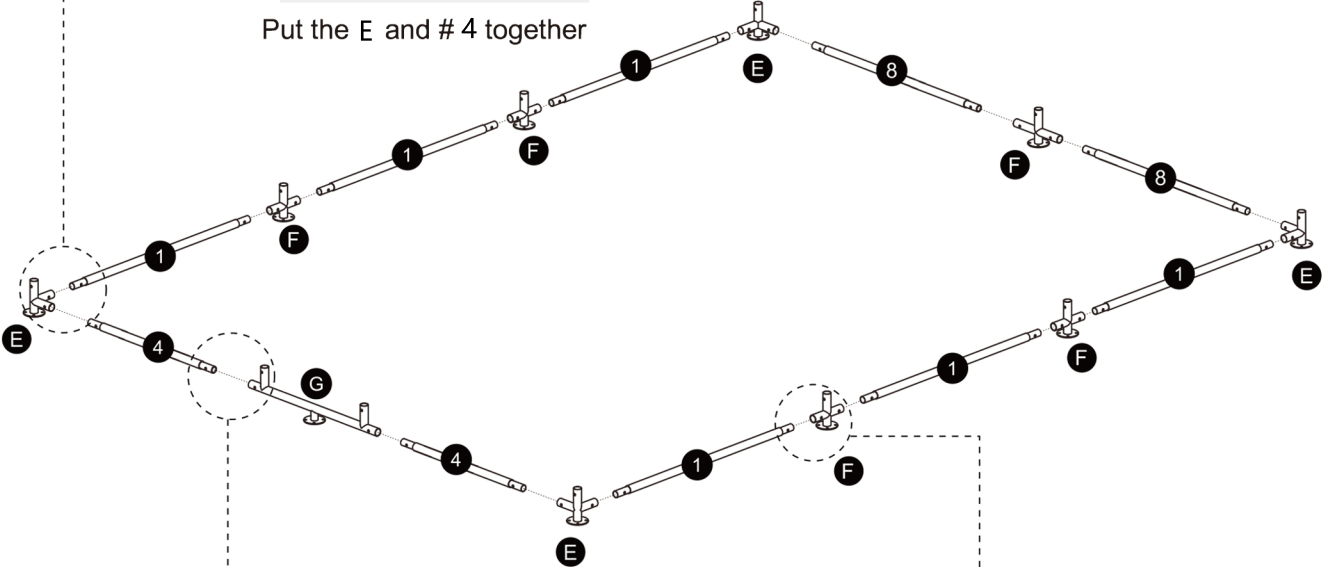

Put the G and # 4 together

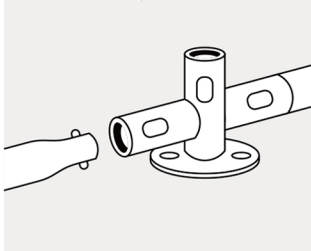

Put the F and # 1 together

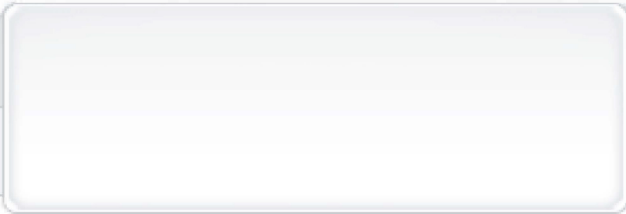

Step 2

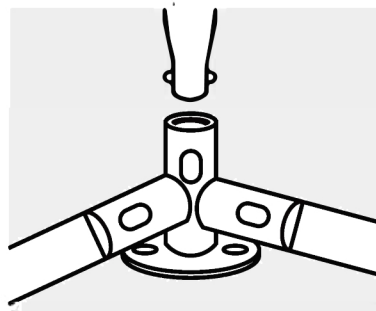
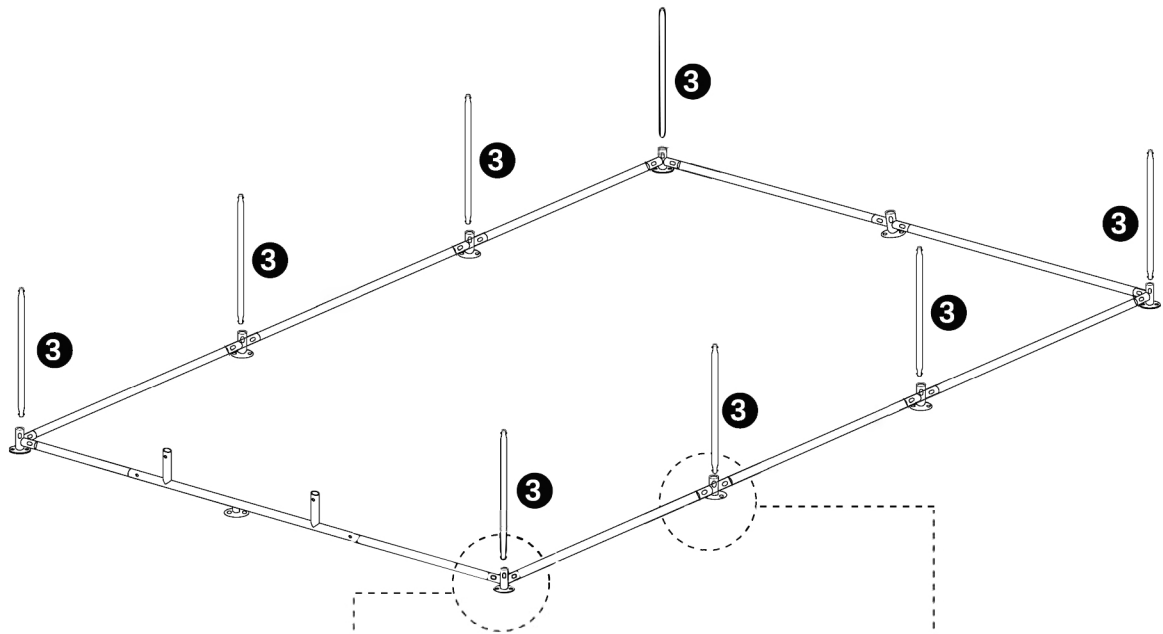
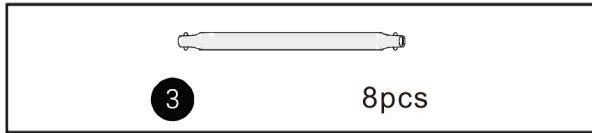

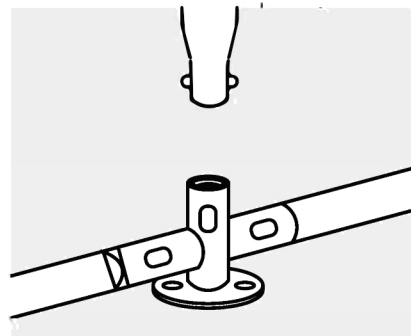

Put # 3 and E together

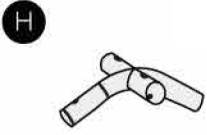
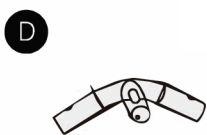

Put # 3 and F together

Step 3

 <p>H 4pcs</p>	 <p>D 4pcs</p>	<p>1 6pcs</p> 
		<p>7 1pc</p> 

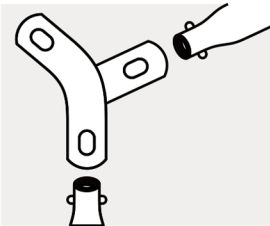
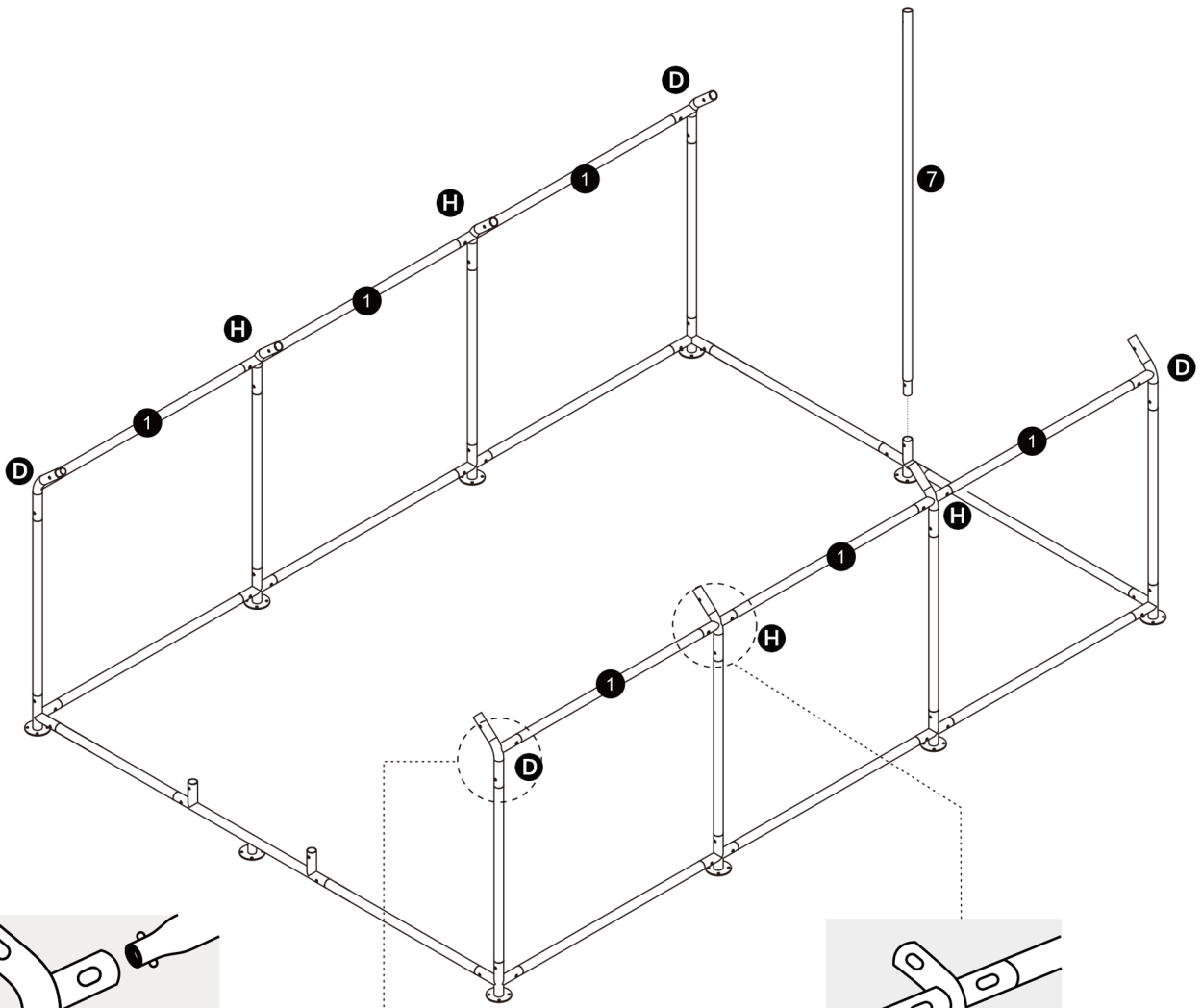

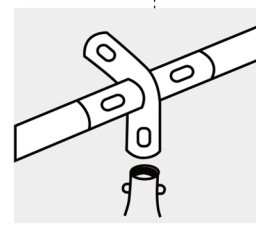

Put the D and # 3 together

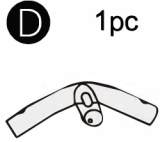
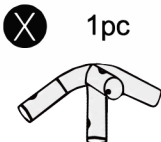
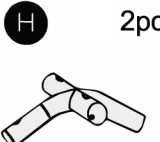

Put the H and # 3 together

Step 4

 <p>D 1pc</p>	 <p>X 1pc</p>	 <p>H 2pcs</p>	 <p>2 8pcs</p>
			 <p>1 3pcs</p>

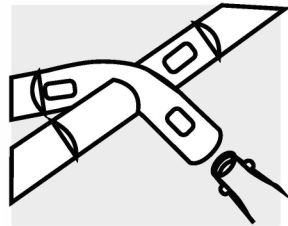

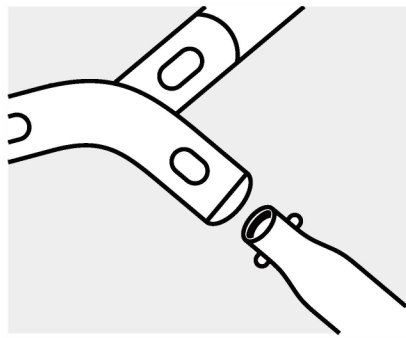
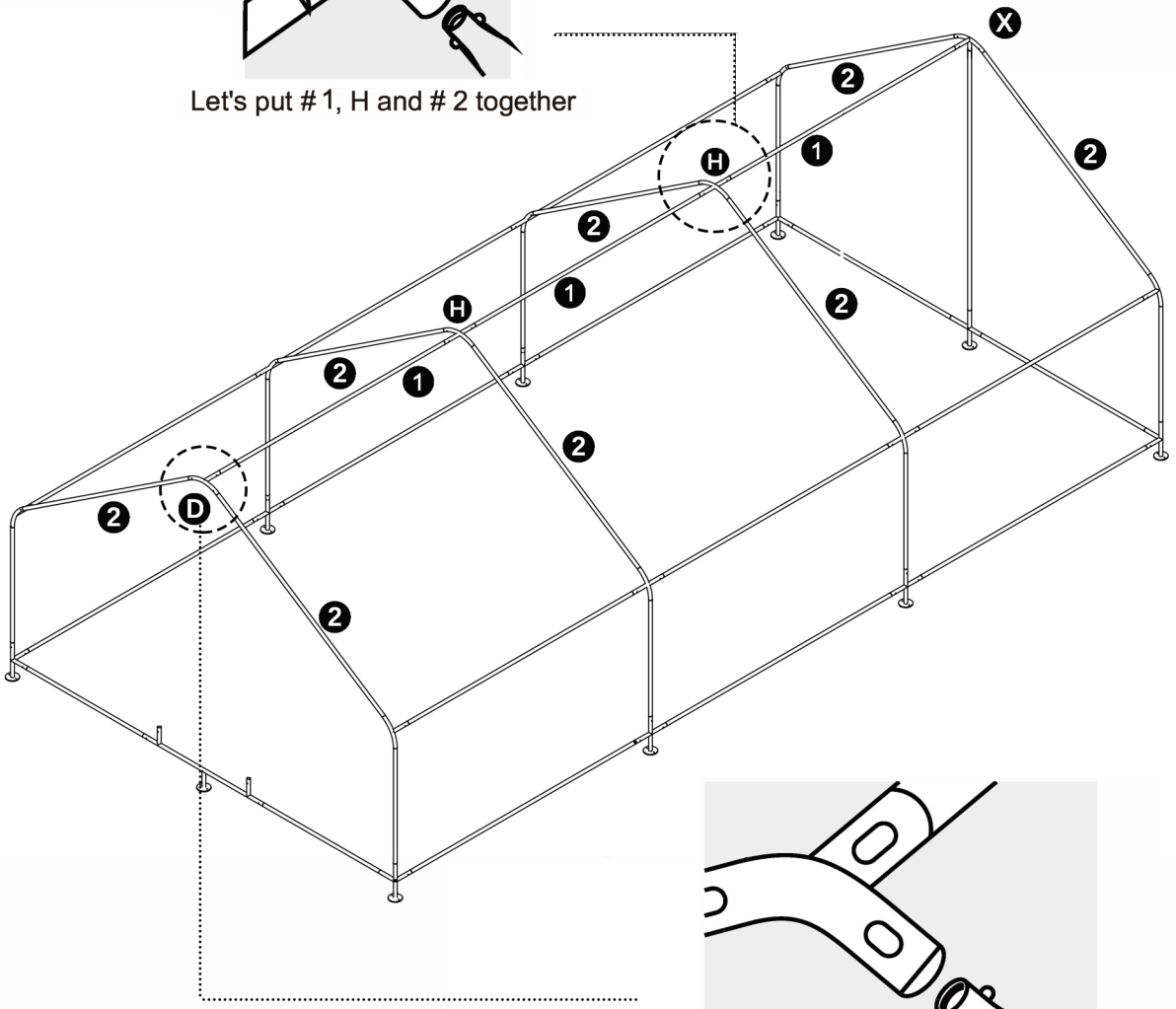

Let's put # 1, H and # 2 together

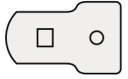

Let's put # 1, D and # 2 together

Step 5

 <p>1pc</p>	 <p>1pc</p>	 <p>1pc</p>
--	--	--

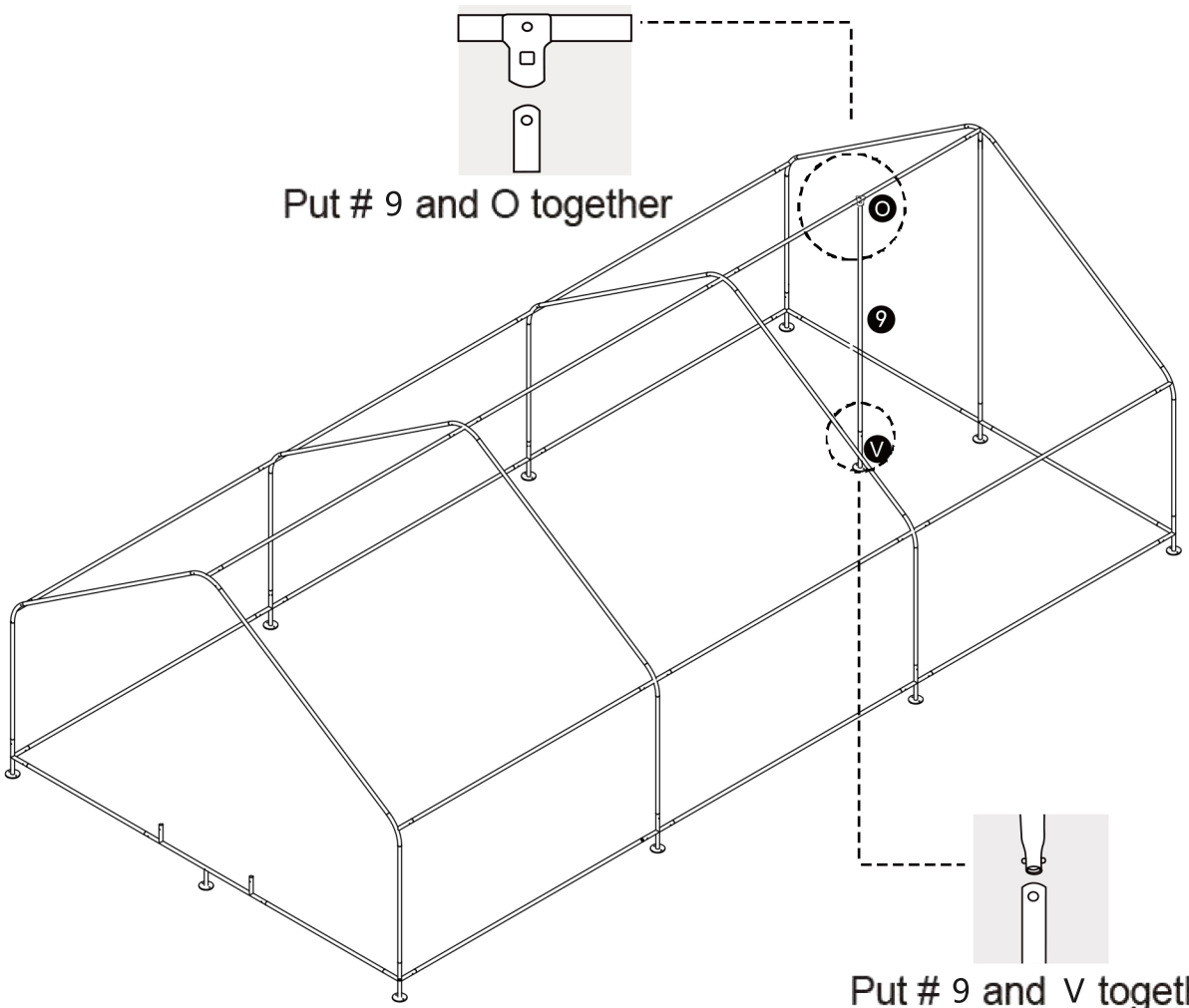

Step 6

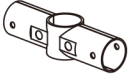
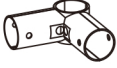
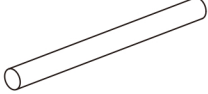
Y  1pc	N  1pc	P  4pcs
--	--	---

Put # 9 and Y together

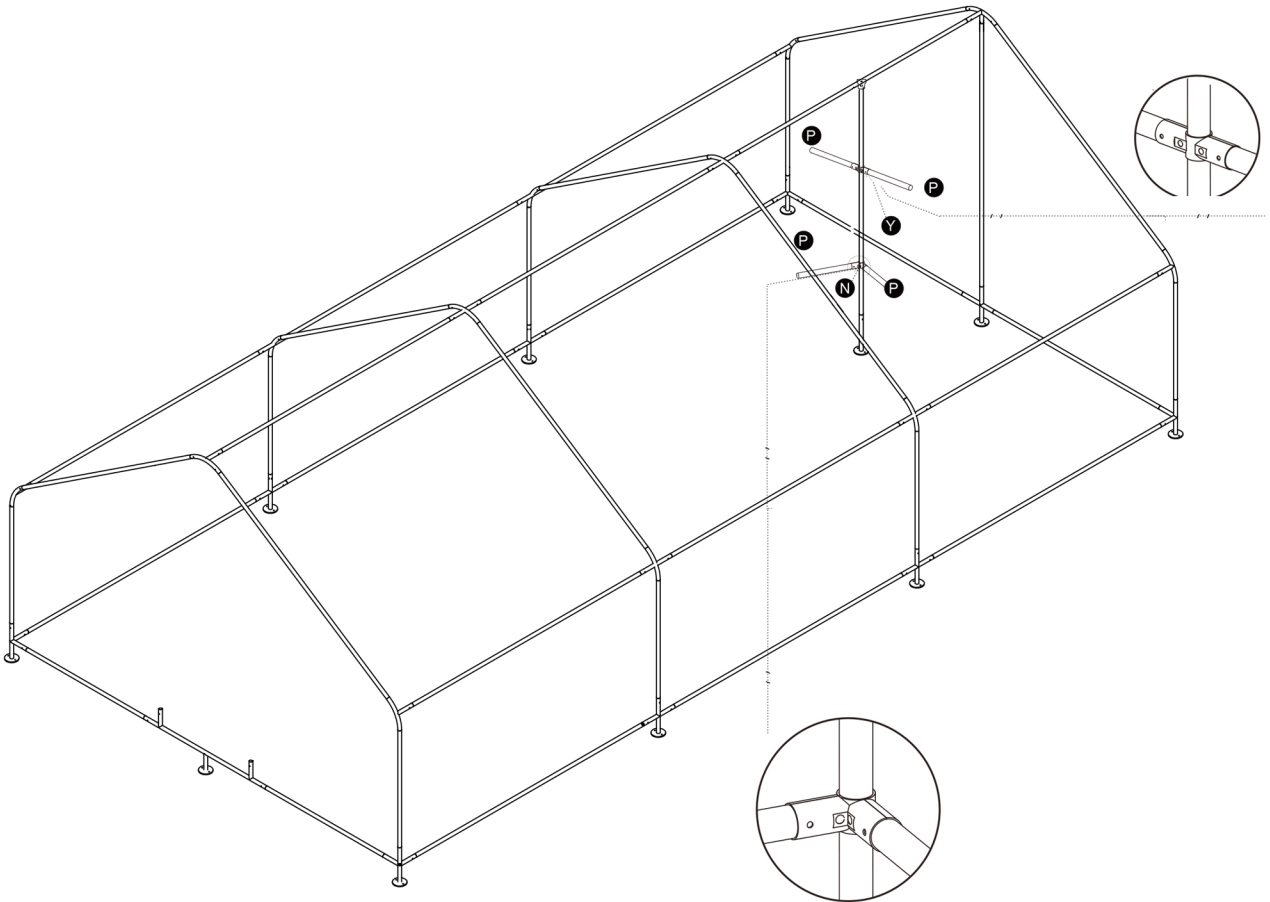

Put # 9 and N together

Step 7

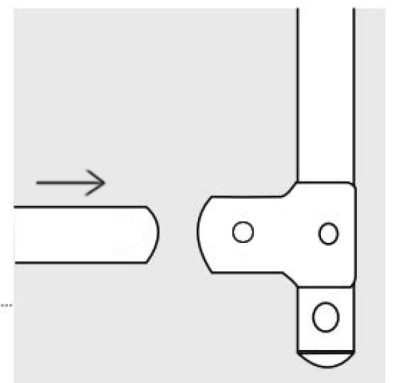
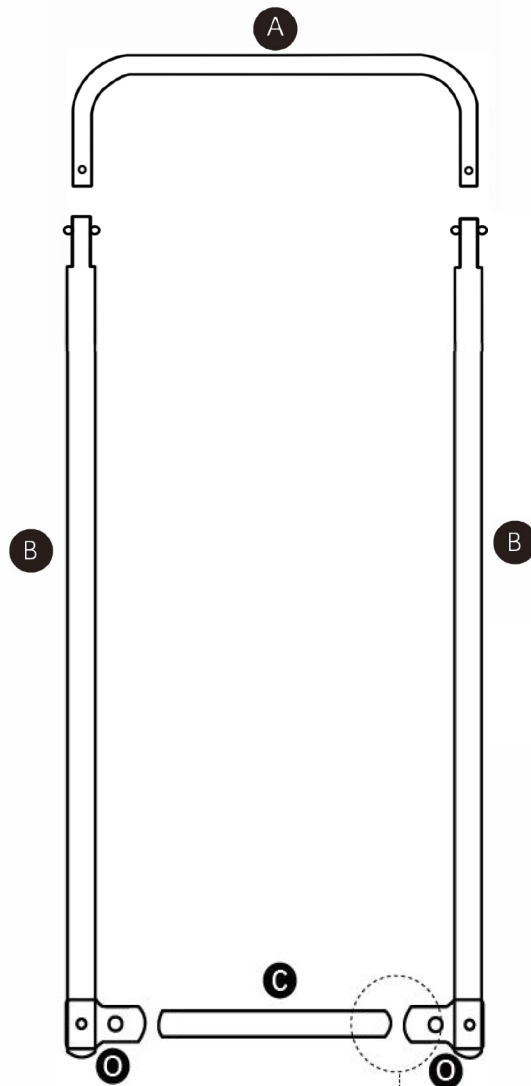
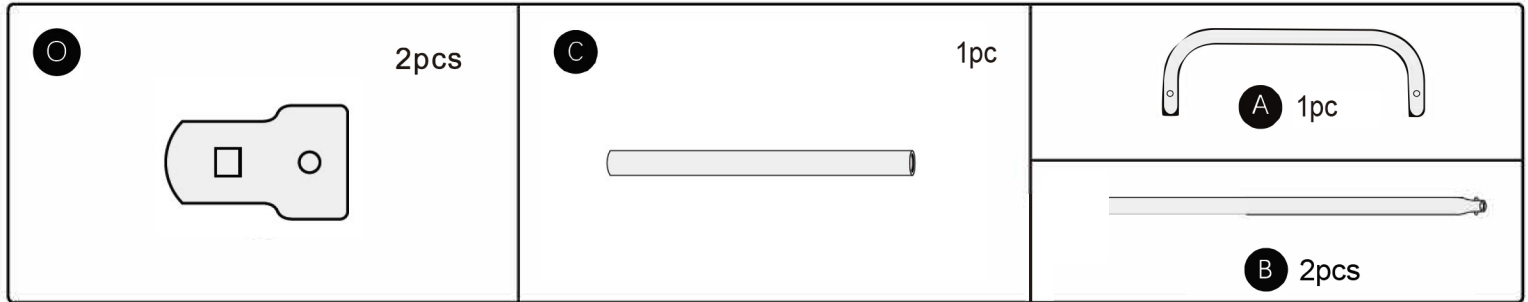

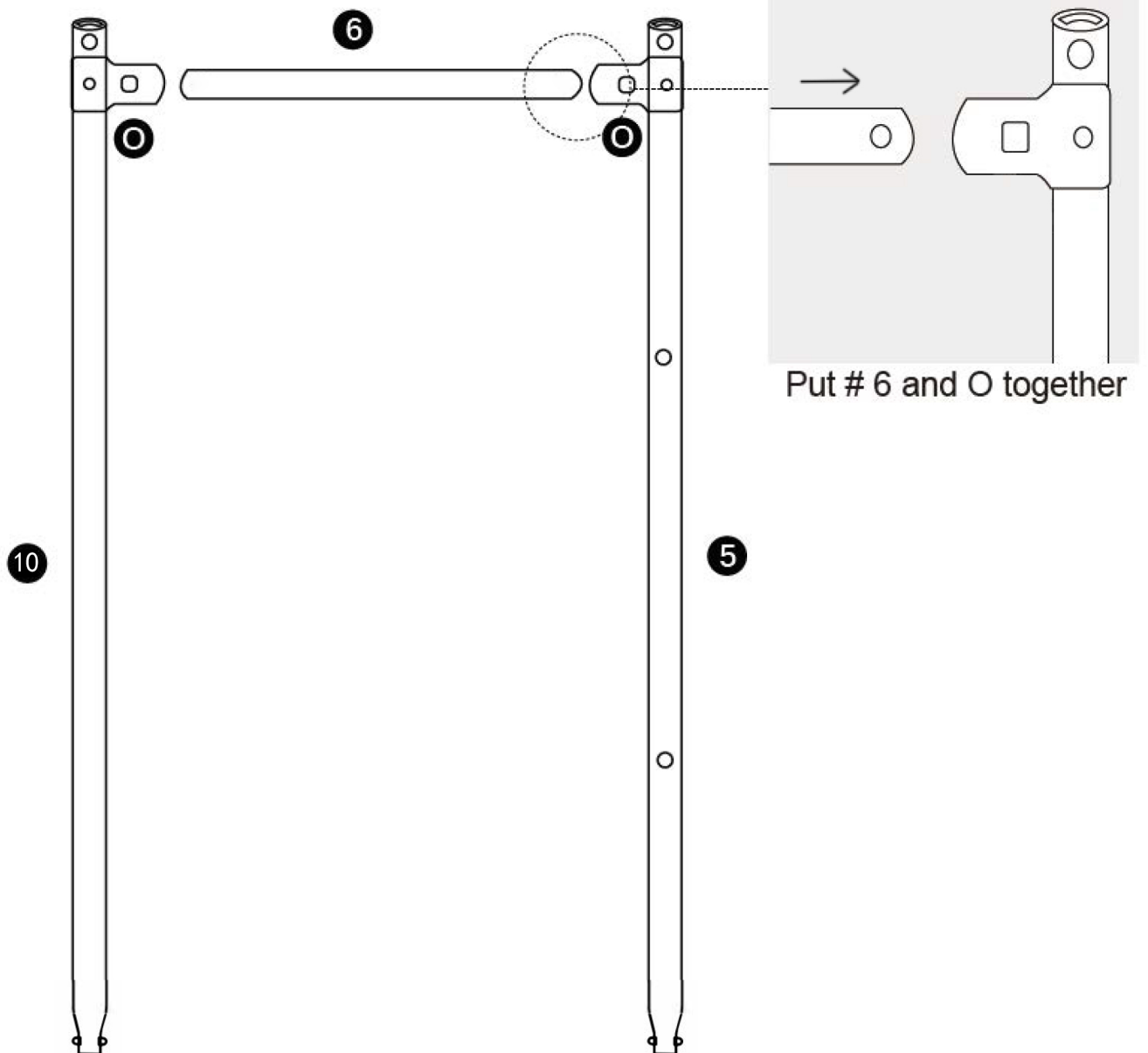
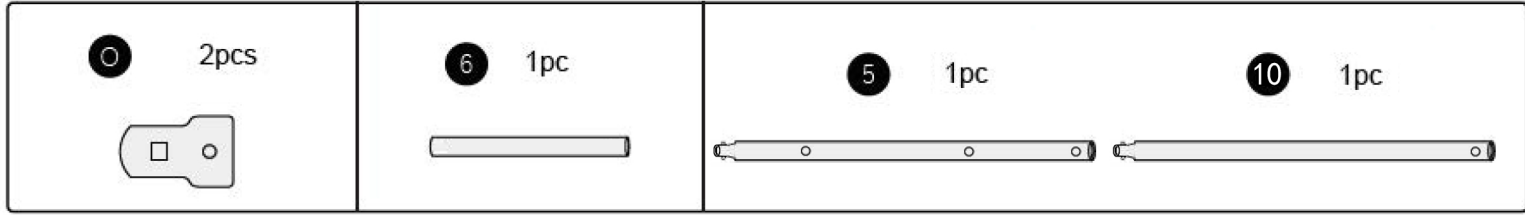

Put the O and C together

Step 8

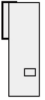

Step 9

<p>I 2pcs</p> 	<p>U 2pcs</p> 	<p>W 2pcs</p> 	<p>Z 4pcs</p> 
--	--	---	--

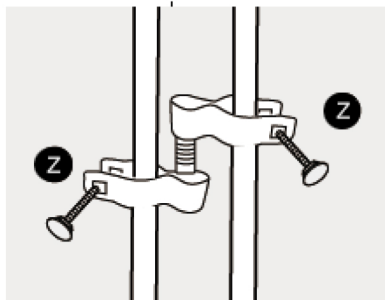
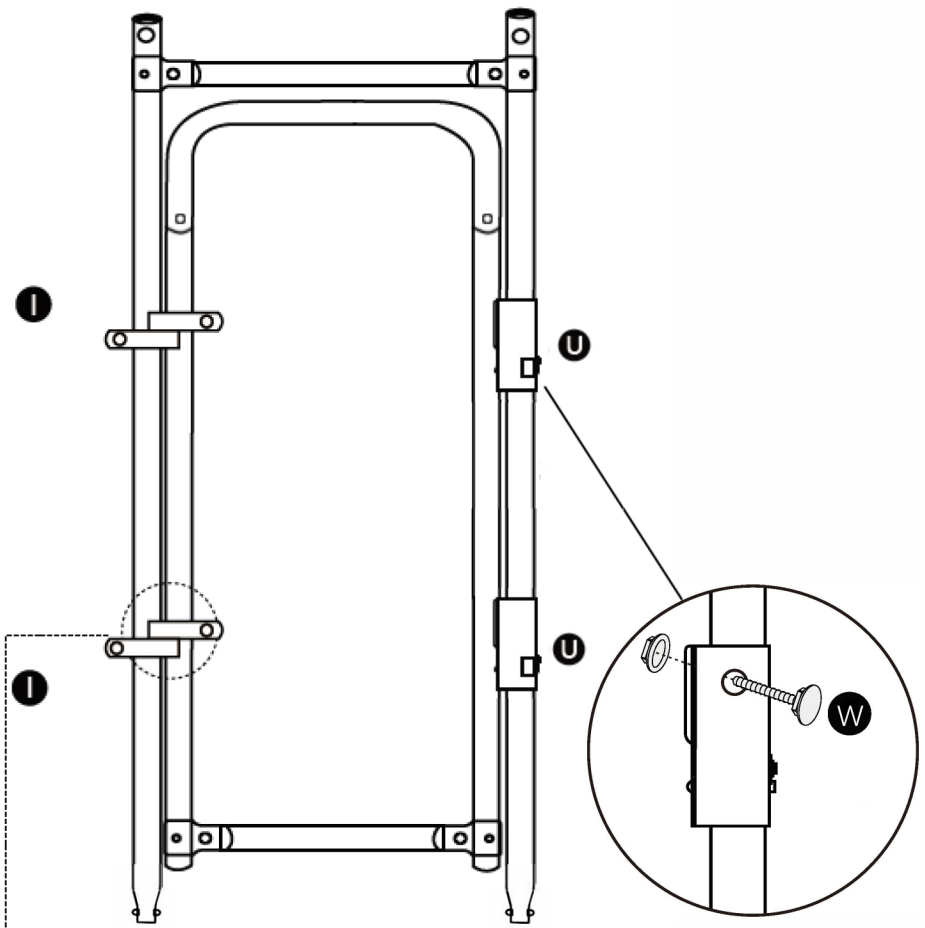

Put the I together

Step 10

L 2pcs M6



M 2pcs

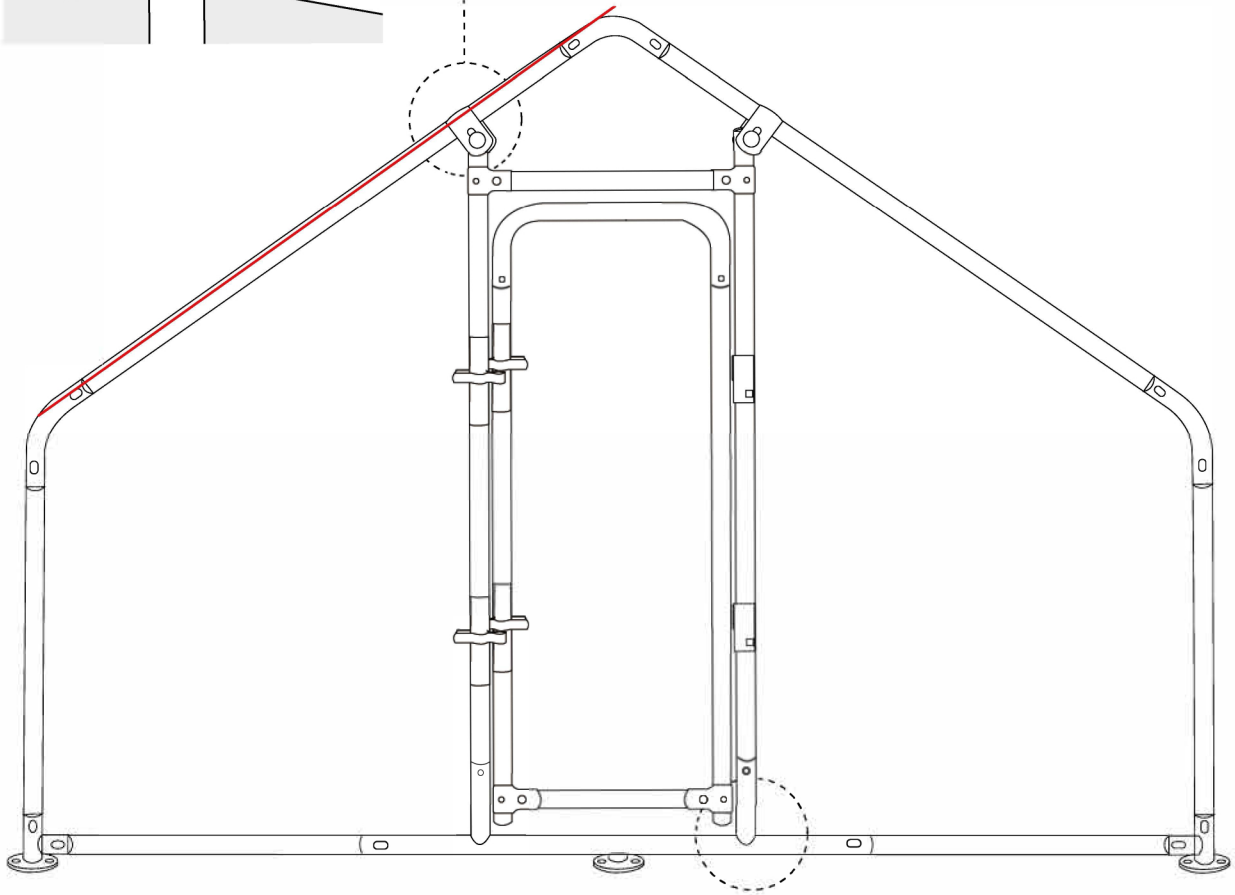
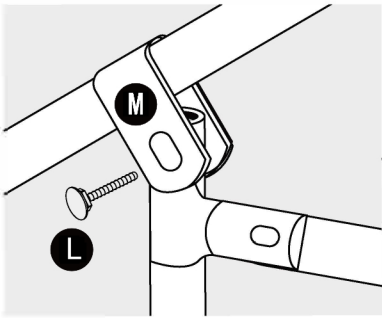

Step 11

hexagonal wire netting		1PC
1PC 		
SIZE:1456.69"*59.1"		

240in

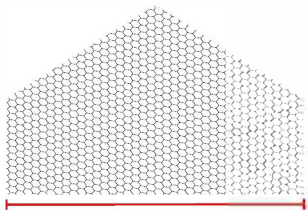
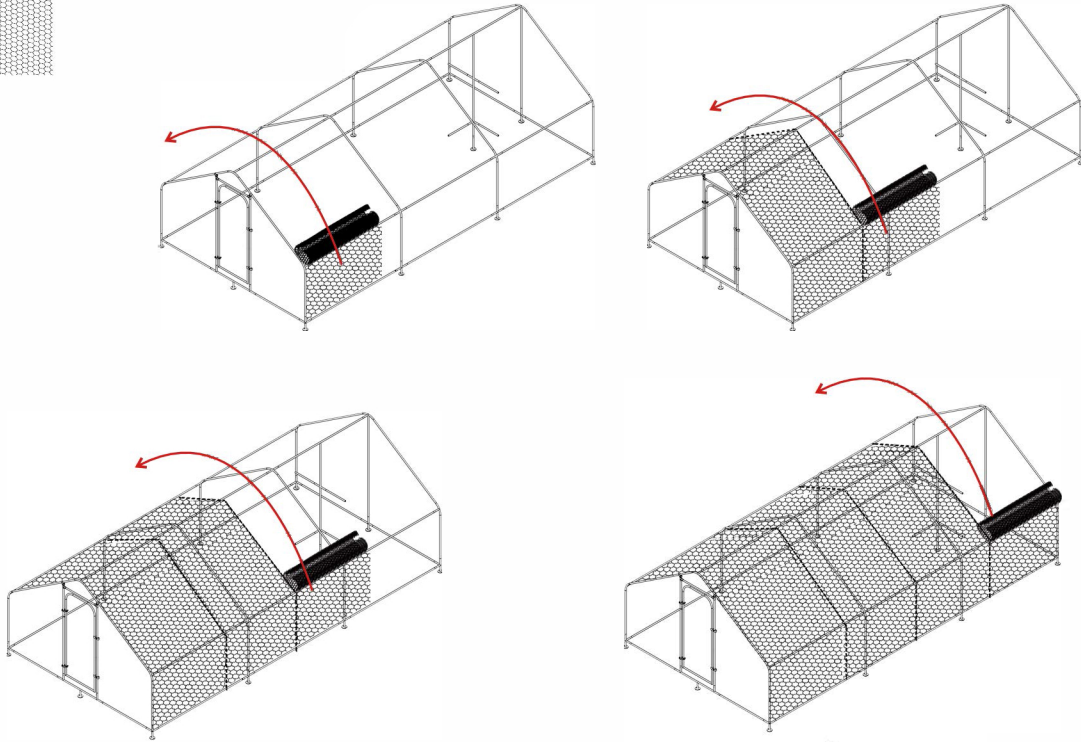
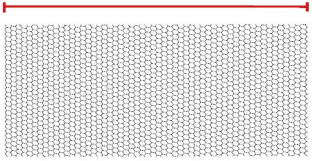

122in

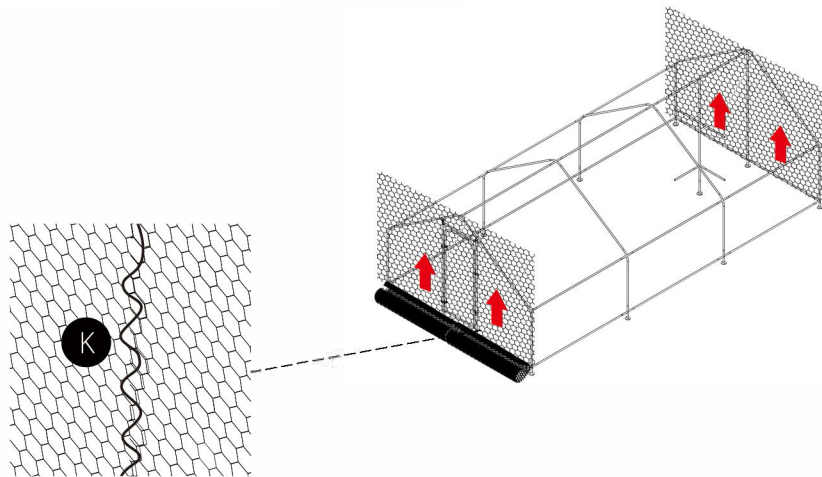

Step 12

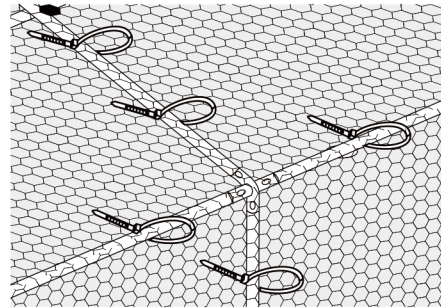
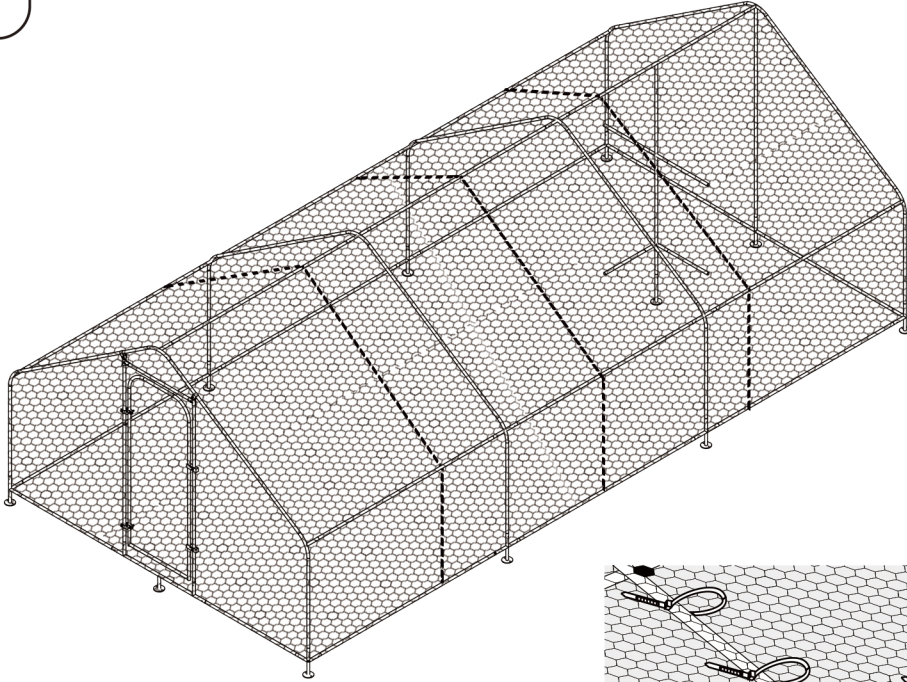
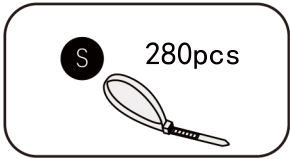

Lock the net cover to the coop via tie straps

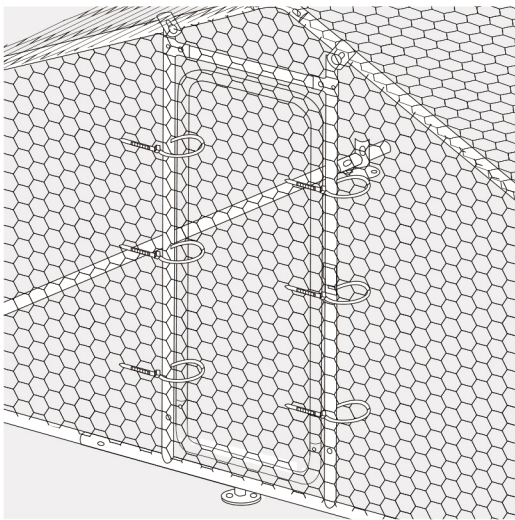

Secure the whole net cover was locked with tie straps

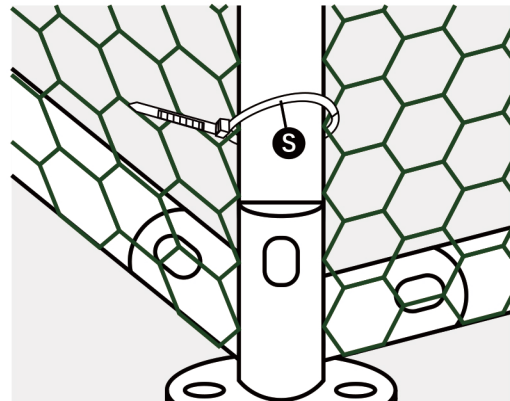

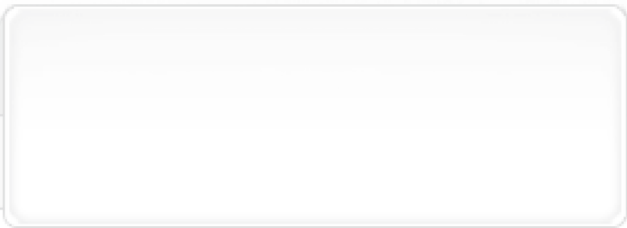

Step 13

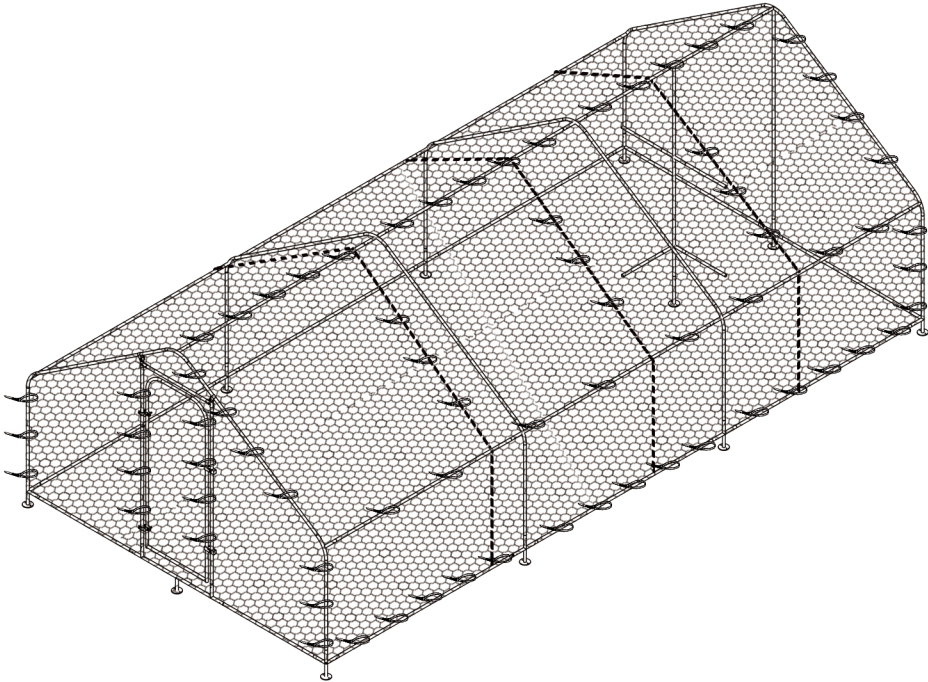

Secure all coop nets with cable ties

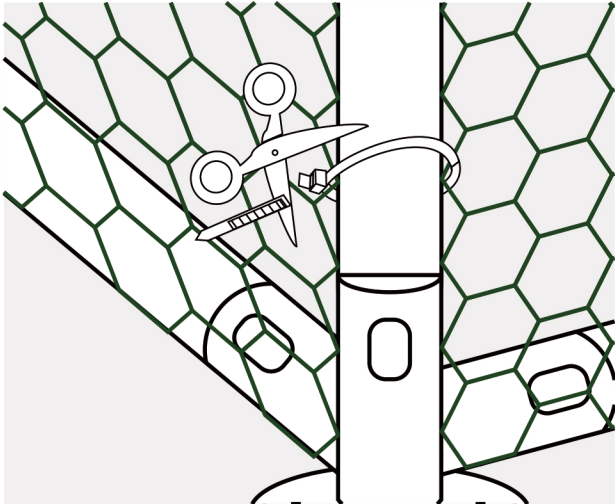

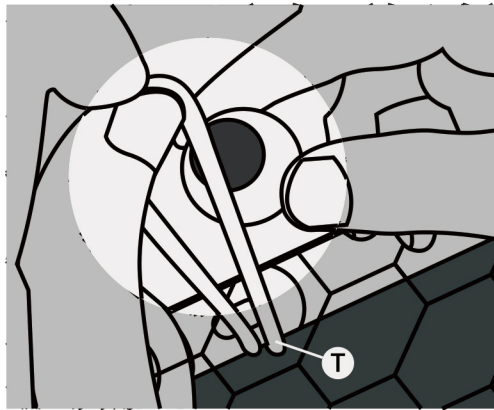
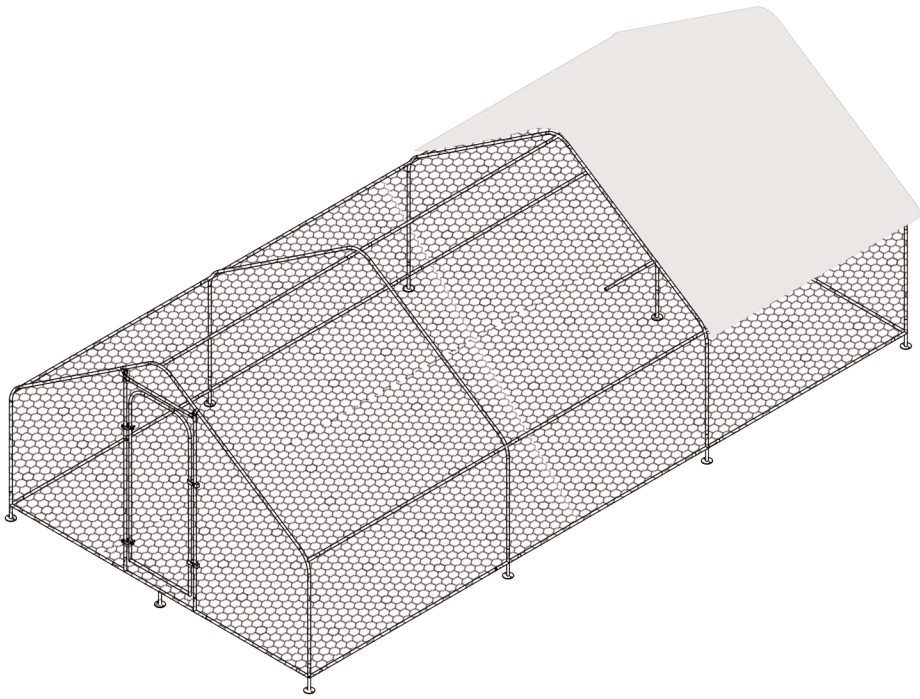
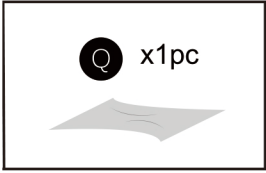

Cut the excess off the cable ties

Step 14



Step 15

 18pcs	 x1pc
---	--

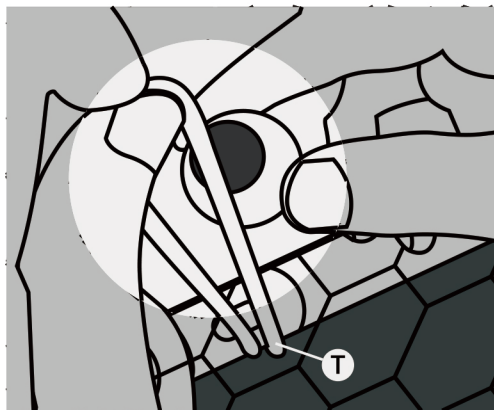
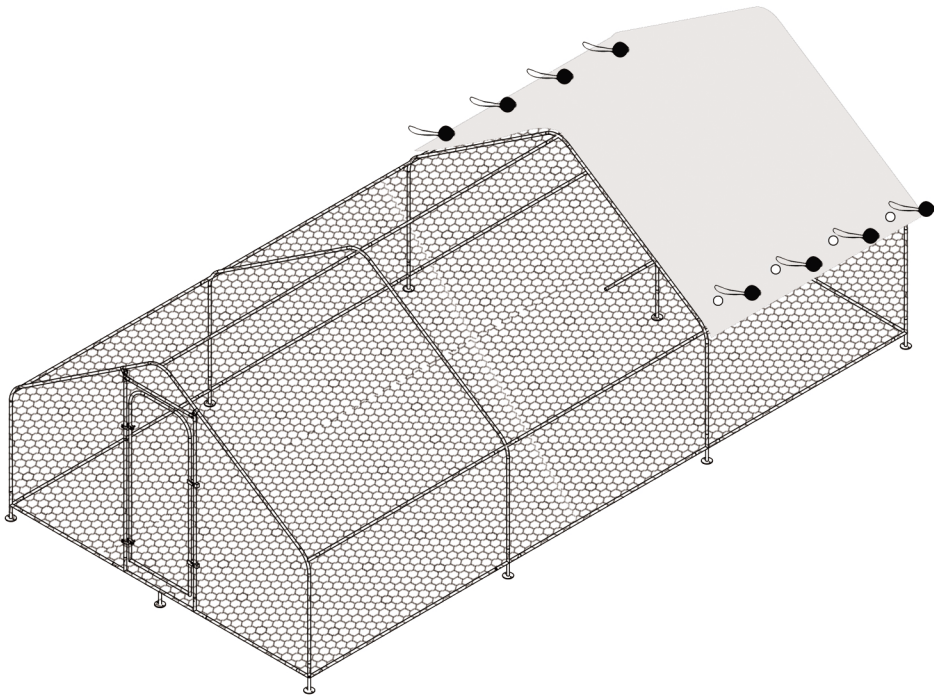

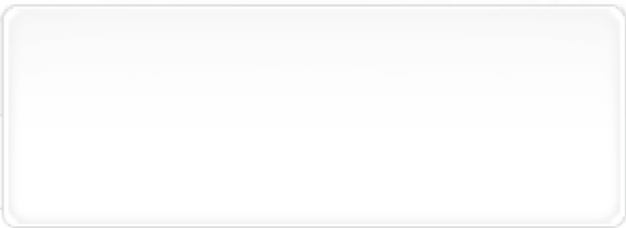

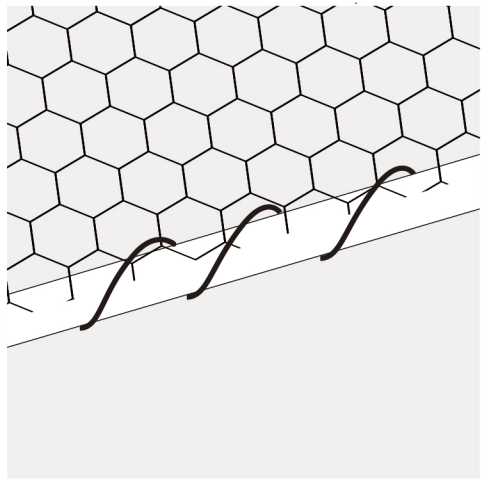
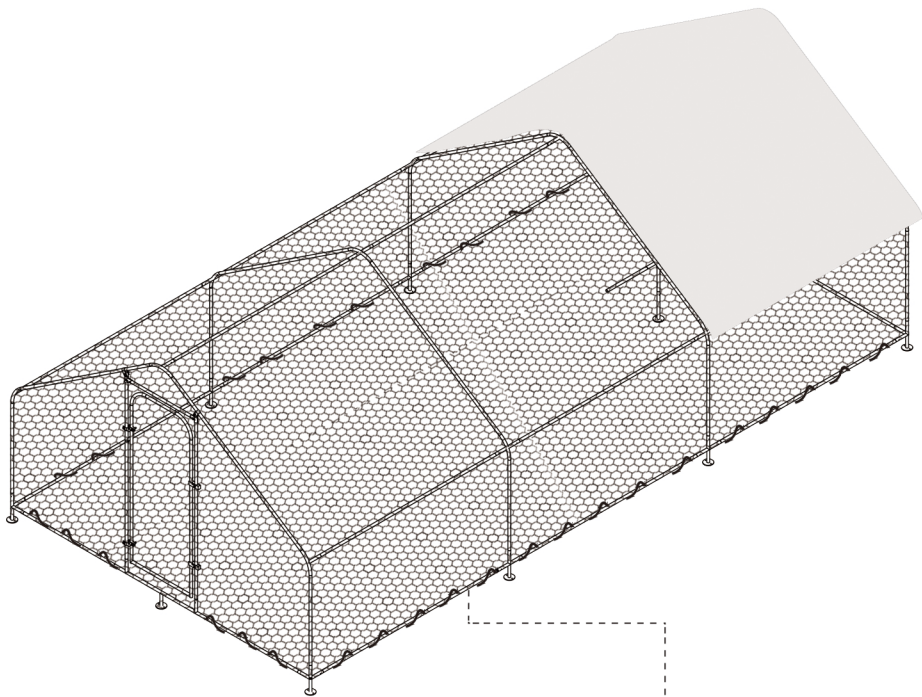
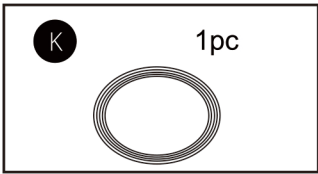

Step 16

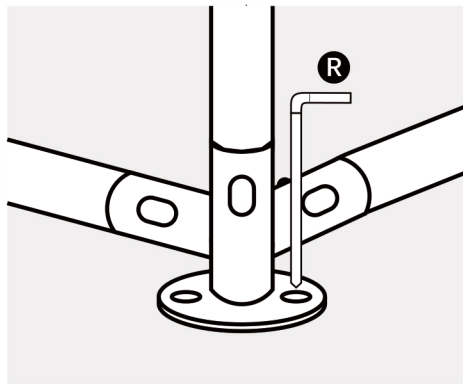
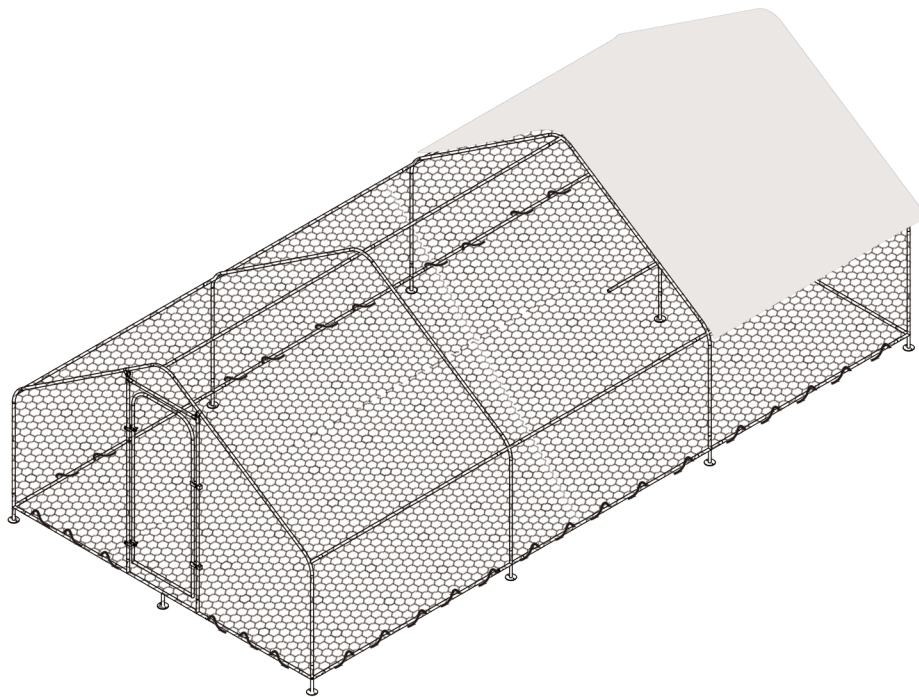

Step 17

R 22pcs



Security/ Notice

- Fasten screws loosely during initial assembly. Do not firmly tighten the screws until the item is completely assembled.
- Be aware that some parts are heavy and have sharp edges.
- If any parts are missing, broken, damaged, or worn, stop using this item until repairs are made and/or factory replacement parts are installed.
- Reconfirm that all bolts, screws, and knobs are secure every 90 days.
- Do not use this item in a way inconsistent with the manufacturer's instructions as this could void the product warranty.

Warranty Guidelines

- Warranty period is determined by date of shipment from Walnest. for factory direct purchases or date of purchase from an authorized reseller. Please save a copy of your purchase receipt.
- If this product or any associated parts are found to be defective or missing at the time of receipt, Walnest will repair or replace, at its option, the defective parts at no charge to the original purchaser. Replacement parts or repaired parts shall be covered for the remainder of the Original Limited Warranty Period. All shipping costs will be the responsibility of the seller.
- Continuous free technical support is provided, including online diagnosis and troubleshooting to users' problems, and come up with solutions in time. In order to process your claim, please upload a copy of your receipt along with AT LEAST 2 photos of the issue/damaged parts. Otherwise, supplier reserves the right to refuse replacement parts or credit.
- If a warranty claim is made after 30 days after purchase for missing or defective parts, the consumer is responsible for costs of parts and shipping.
- We reserve the right to the final explanation of above warranty policy. Please contact our Customer Service

What is not covered by this limited warranty?

- Item past the warranty.
- Products that has been subjected to abuse, overweight, accident, alteration, modification, tampering, vandalism, negligence, misuse, abrasive contact, faulty installation or lack of reasonable care.

- Damage to the contents of products, any person or property is excluded. Normal and foreseeable service wear or tear.
- Parts damaged due to improper installation or assembly.
- Damage that occurs due to acts of nature, i.e. hurricane, tornado, wind, flood, snow, wind driven debris, etc.
- Third party labor or installation fees of any kind are not recoverable under the warranty.
- Other circumstances stipulated by law.

Return Policy

Return is available if you are unsatisfied with the product or bought the wrong item within 1 month of receiving item. Please contact us via platform message, and we will send you the free prepaid return label.

The item should be returned in original unused condition and in the original packaging. Refunds typically take 2 business days after we have received and inspected your returned order. Please NOTE, the refund might be partial deducted in the following cases:

1. The returned item condition is different with reported;
2. Parts used or missing of returned item;
3. Buyer remorse purchase return, such as item no longer needed, wrong color/ size purchased, doesn't fit or like.

The Return Policy may not apply in all cases, depending on factors such as condition of the product, where the product was purchased, or whom you purchased the product from. Please email the purchase platform if you have any questions.

Contact US

Please contact us with any comments, questions or suggestions that you may have by sending messages or call us. All the mails will be replied within 24 hours. Please ensure your mail box would not block / filter our mails. We will surely give you a satisfactory service.