

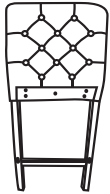

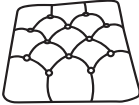

Ax1 Back	Bx1 SEAT	Cx2 FRONT LEGS	Dx3 SIDE STRETCHERS-CD FOOTREST	Ex9 SCREWS	Fx6 TAPPING SCREWS	Gx9 WASHER	Hx1 SPANNER	Ix9 SPRING WASHER
				 M8x60mm	 M4.5x45mm			

STEP1

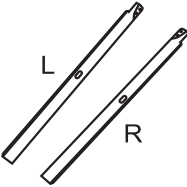
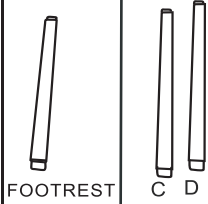
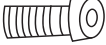

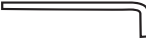
Loosely install the center bolt first, then loosely install both sides

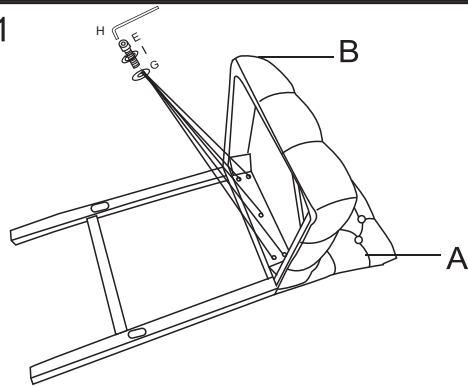
STEP2

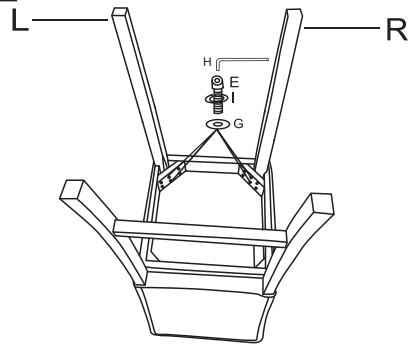

Firm pressure is required to push legs into the leg pockets

STEP3

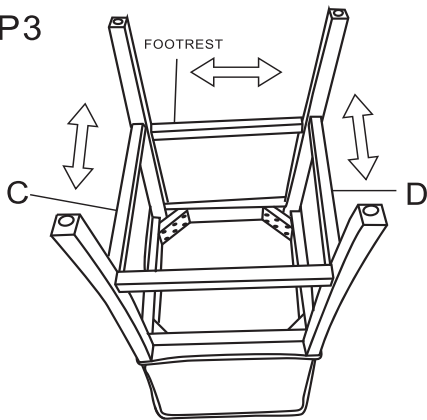

Note: Side stretchers are directional

STEP4

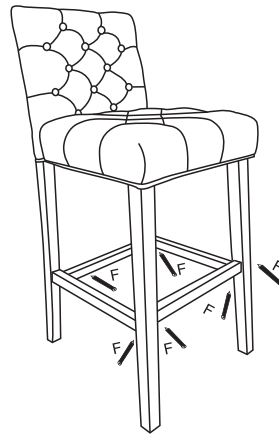

Tighten all bolts properly on even ground

ASSEMBLY INSTRUCTION

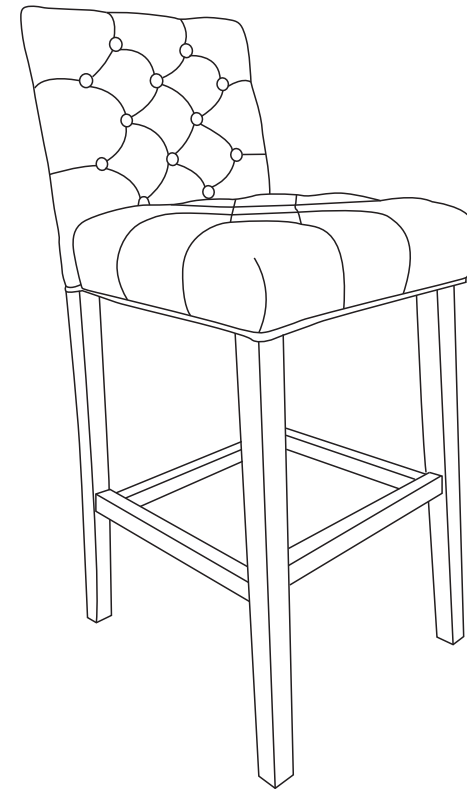

CLEANING OF PULEATHER COVER - WIPE CLEAN WITH A SOFT CLOTH MOISTENED WITH WATER AND NEUTRAL DETERGENT. DO NOT USE BLEACH,CHEMICAL OR BIOLOGICAL CLEANERS.