

# Assembly Instruction (HQ-033)

## Parts List

Open the hardware check all parts QTY, thanks

 Assemble on a mat that is not easy to scratch

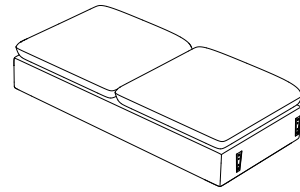
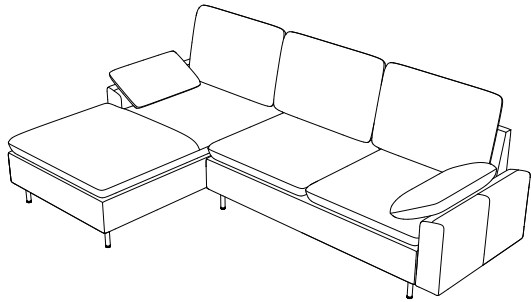

A x 1

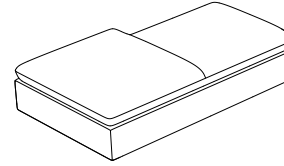

B x 1

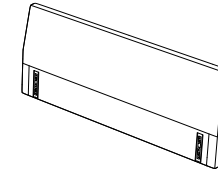

C x 1

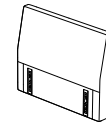

D x 1

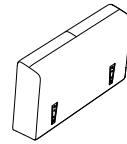

E x 2



F x 3



G x 2

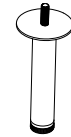

H x 9



### Step 1

Open the hook & loop tape on bottom of "A". Take out "E", "F", "G".

1/2 carton

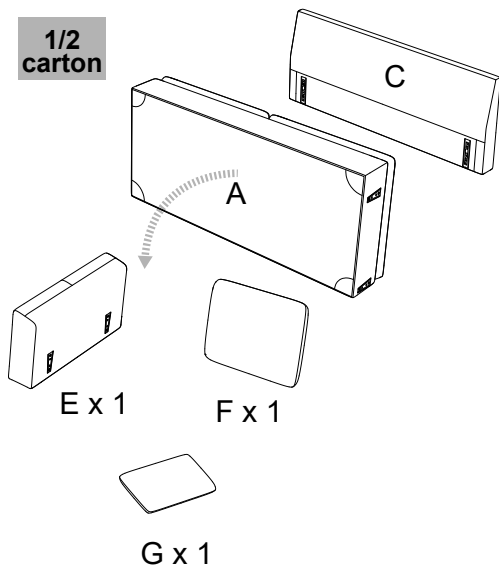

### Step 2

Open the hook & loop tape on bottom of "B". Take out "D", "E", "F", "G", "H".

2/2 carton

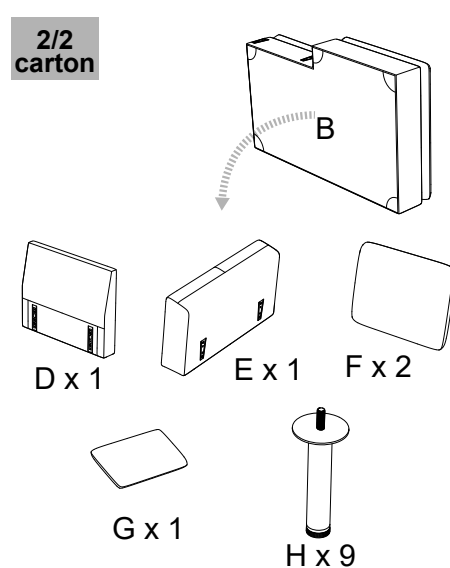

### Step 3

Close the hook & loop tape on bottom of "A" and "B". Tighten clockwise "H".

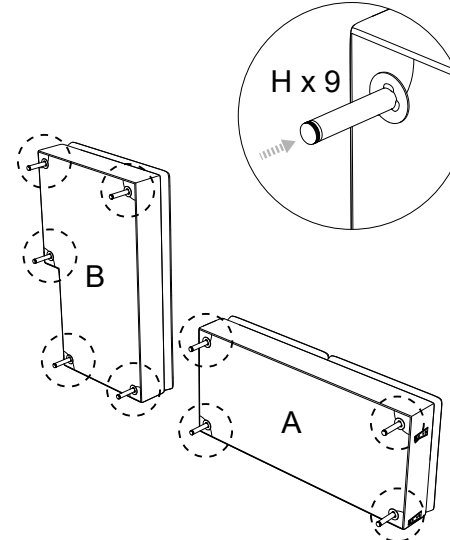

### Step 4

Rotate out saw lock under hook & loop tape of "A". Push "A" to "B".

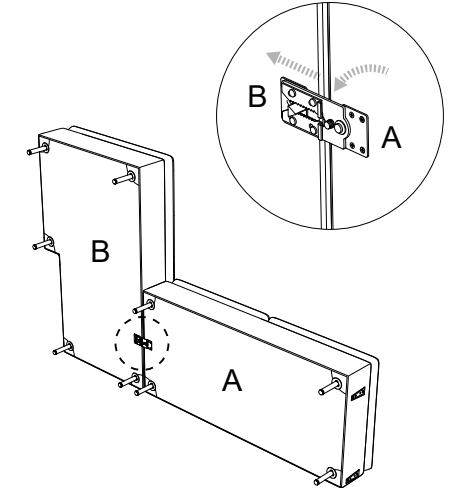

If disassemble after installation, press "A" and pull up "B".

## Step 5

Press "C" inserting pieces into "A" slots.  
Press "D" inserting pieces into "B" slots.

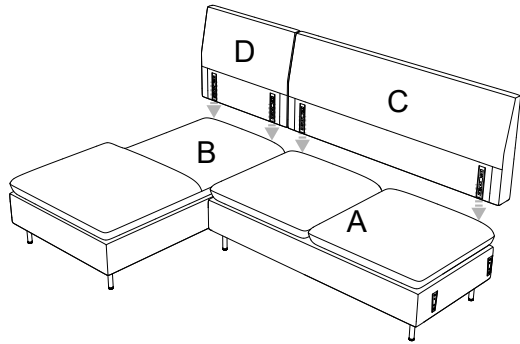

## Step 6

Press "E" inserting pieces into "A"  
and "B" slots.

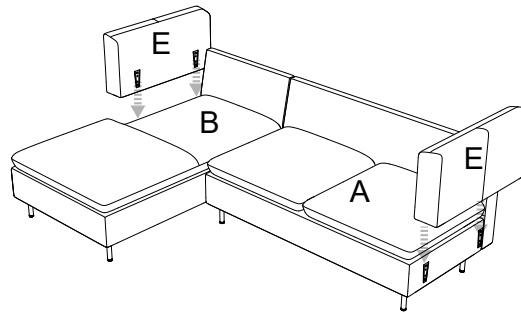

## Step 7

Place the backrest cushions "F".  
Place the armrest cushions "G".

