

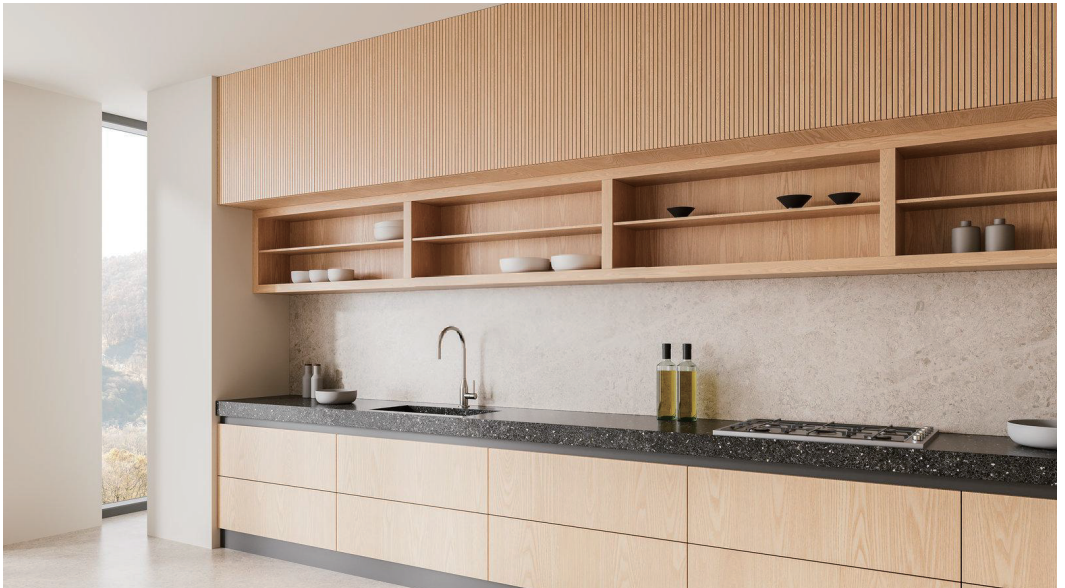

ASSEMBLY INSTRUCTIONS



One of the unique features of Homsee furniture is its versatility. Designed with the idea of customization in mind, our products can be easily linked together to create seamless, personalized setups that fit your specific needs.

For instance, if you purchase a couple of our shelves, you can effortlessly combine them to form a larger, unified structure. This modular approach allows you to expand, rearrange, and adapt your furniture as your space and style evolve. Whether you're looking to create a vast shelving system, or a continuous storage solution, the possibilities are endless.

At Homsee, we empower you to create a space that is truly yours—one that grows with you, all while maintaining a sleek, cohesive look.



Una de las características distintivas del mobiliario Homsee es su versatilidad. Diseñados pensando en la personalización, nuestros productos pueden conectarse fácilmente entre sí para crear configuraciones continuas y personalizadas que se ajusten a tus necesidades específicas.

Por ejemplo, si compras un par de nuestras estanterías, puedes combinarlas sin esfuerzo para formar una estructura más grande y unificada. Este enfoque modular te permite ampliar, reorganizar y adaptar tus muebles a medida que evolucionan tu espacio y tu estilo. Ya sea que busques crear un amplio sistema de estanterías o una solución de almacenamiento continua, las posibilidades son infinitas.

En Homsee, te ayudamos a crear un espacio verdaderamente tuyo—uno que crece contigo, manteniendo a la vez un aspecto elegante y coherente.

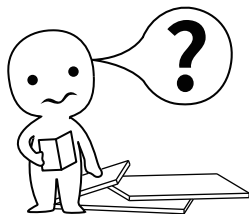

IMPORTANT INFORMATION!

Please read the entire manual before starting to assembling or using this product. Follow the manual thoroughly and keep it for further reference.

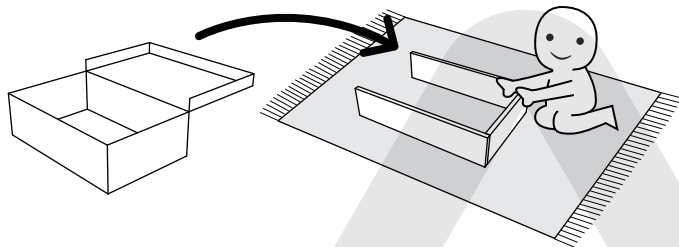

AVOID SCRATCHES!

In order to avoid scratching the furniture should be assembled on a soft layer—could be a rug.

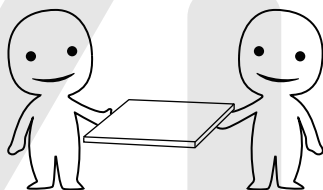

IMPROVE ASSEMBLY EFFICIENCY !

Try to find a partner to install with you, which can speed up the installation efficiency and shorten the time.

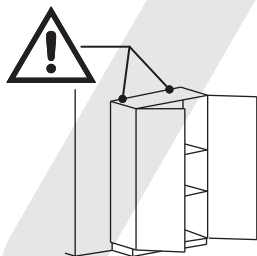

ANTI-TOPPLE WARNING !

Overturned furniture can cause serious or fatal crush injuries. To prevent tipping, be sure to use a wall-anchoring attachment. If one is not included with this product, please purchase a suitable attachment that fits your wall. If unsure, seek professional advice. Please read and follow all instructions carefully.

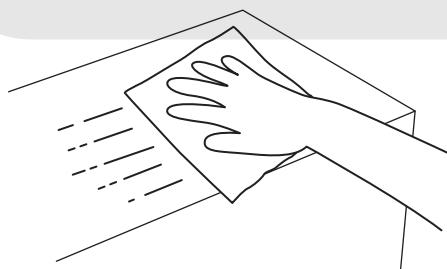

MAINTENANCE AND CLEANING !

For regular maintenance and cleaning, use a rag dipped in neutral detergent to wipe the frame thoroughly, and then dry it with a clean rag. For glass surfaces, wipe with a rag dampened with water or glass cleaner, and then dry with a clean, dry cloth.



¡INFORMACIÓN IMPORTANTE!

Por favor, lee todo el manual antes de comenzar a ensamblar o usar este producto. Sigue las instrucciones detenidamente y consérvalo para futuras consultas.

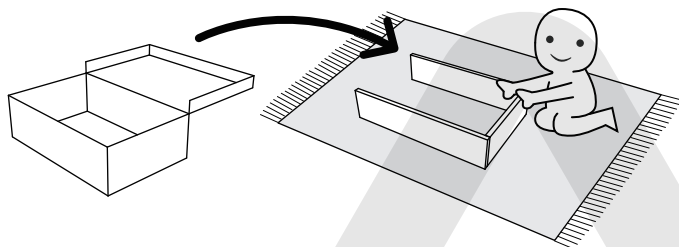

¡EVITA LOS RAYONES!

Para evitar que el mueble se raye, debe ensamblarse sobre una superficie suave, como una alfombra.

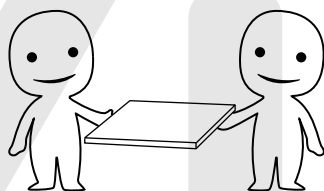

¡MEJORA LA EFICIENCIA!

Intenta encontrar a alguien que te ayude con la instalación; trabajar en pareja puede aumentar la eficiencia y reducir el tiempo de montaje.

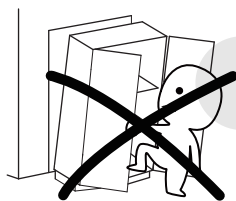
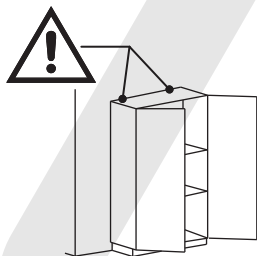

¡ADVERTENCIA ANTIVUELCO!

El mobiliario volcado puede causar lesiones graves o incluso mortales por aplastamiento. Para evitar que se vuelque, asegúrate de utilizar el sistema de anclaje a la pared. Si este producto no lo incluye, adquiere un anclaje compatible con tu pared. Si no estás seguro de cuál usar, busca asesoramiento profesional. Lee y sigue cuidadosamente cada paso de las instrucciones.

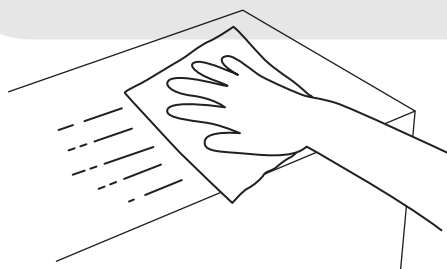

¡MANTENIMIENTO Y LIMPIEZA!

Para el mantenimiento y la limpieza regulares del producto, limpia el marco con un paño humedecido en un detergente neutro y luego sécalo con un paño limpio. Para los materiales de vidrio, límpialos con un paño humedecido en limpiador de vidrios con agua y luego sécalos con un paño seco.



The following are common installation steps. Correct operation is required to avoid product damage.

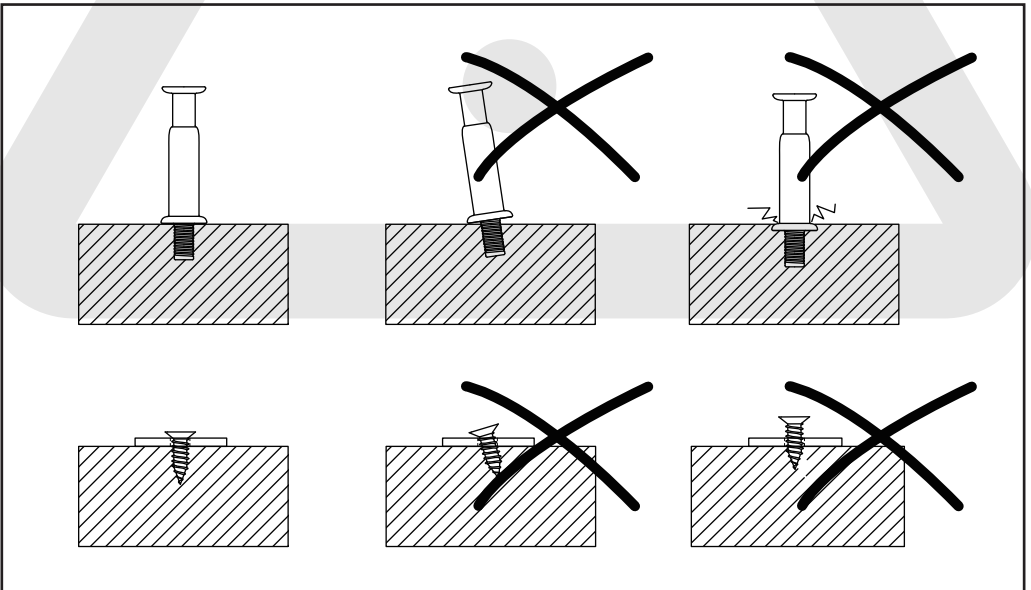
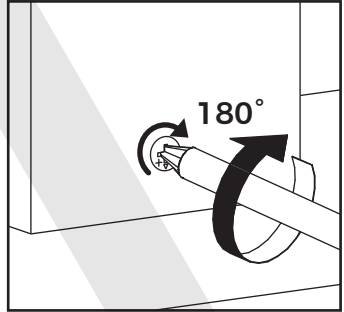
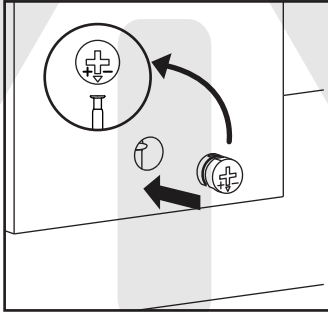
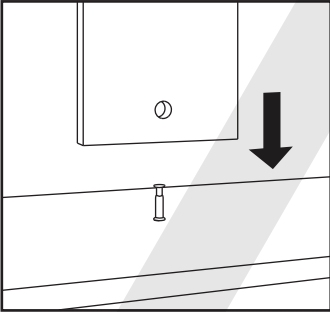
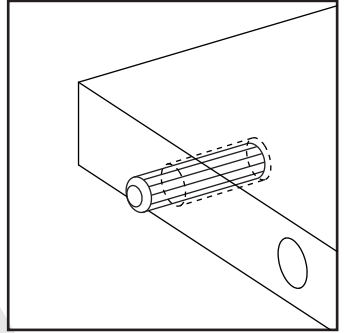
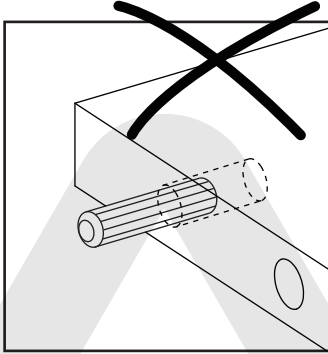
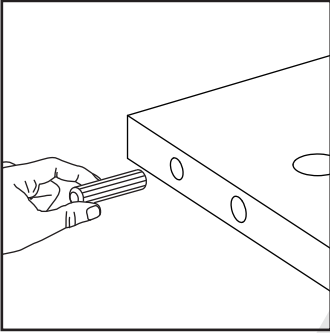



Los siguientes pasos de instalación son bastante comunes y requieren una operación correcta durante el proceso de montaje. El uso incorrecto puede dañar el mueble.

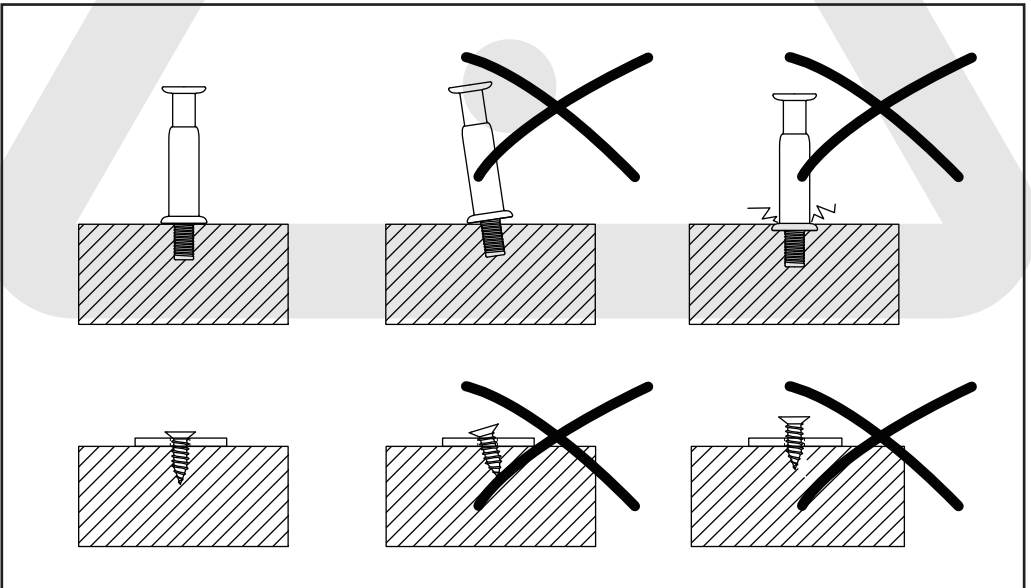
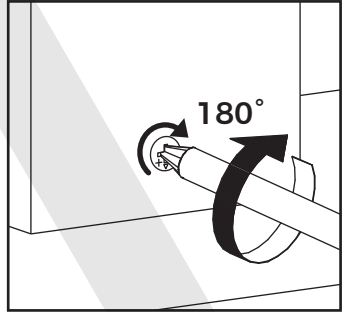
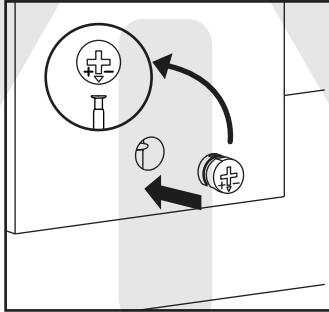
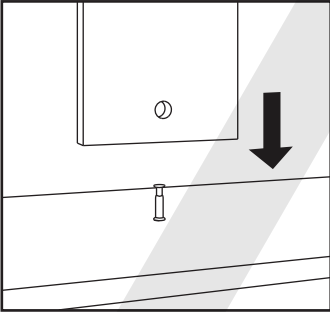
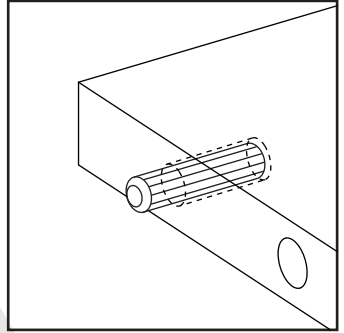
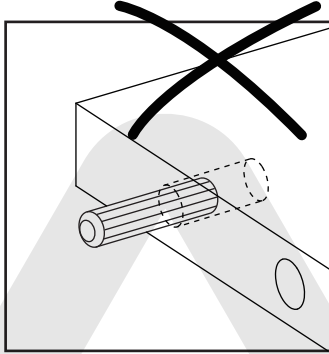
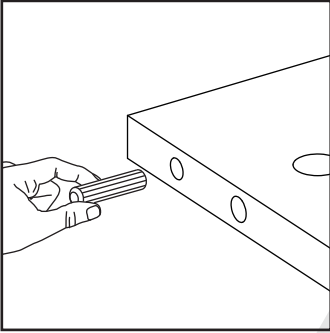



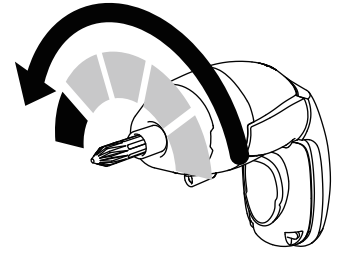
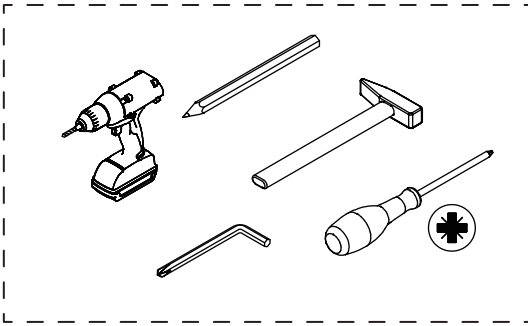







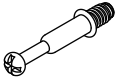

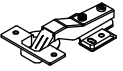
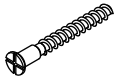

Please prepare the following tools

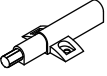

If you choose to use power tools, set it to the lower power setting. Be careful! Power tools can cause cracking or damage to the furniture, and damage the hardware.

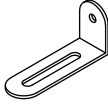

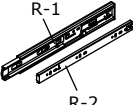
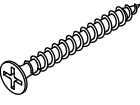
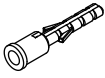
Some accessories have similar shape, please distinguish them according to their numbers and sizes during installation.

<p>A x 64</p>  <p>∅15 x 10 mm</p>	<p>B x 64</p>  <p>∅6 x 35 mm</p>	<p>C x 24</p>  <p>∅6 x 30 mm</p>	<p>D x 64</p> 	<p>E x 16</p>  <p>∅3.5 x 12 mm</p>
<p>F x 4</p> 	<p>G x 14</p>  <p>∅5 x 40 mm</p>	<p>H x 66</p>  <p>∅3.5 x 14 mm</p>	<p>J x 8</p>  <p>∅3.5 x 20 mm</p>	<p>K x 4</p> 
<p>L x 4</p> 	<p>M x 12</p> 	<p>N x 12</p>  <p>∅3 x 14 mm</p>	<p>P x 2</p> 	<p>Q x 2</p> 
<p>R x 4</p>  <p>R-1 R-2 300 mm</p>	<p>S x 2</p>  <p>∅3.5 x 35 mm</p>	<p>T x 2</p> 	<p>U x 4</p> 	<p>V x 4</p> 

Por favor, prepara las siguientes herramientas

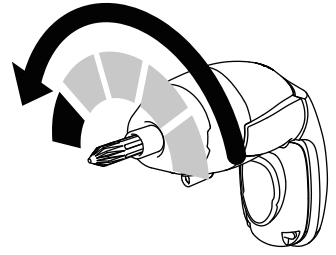
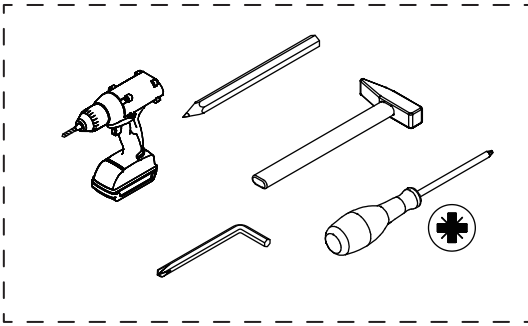

Si decides utilizar herramientas eléctricas, ajústalas a una velocidad baja. ¡Ten cuidado! Las herramientas eléctricas pueden causar grietas o daños en el mueble, y también pueden dañar los herrajes.



Algunos accesorios tienen la misma forma: por favor, distínguelos según sus números y tamaños durante la instalación.

<p>A x 64</p> <p>Ø15 x 10 mm</p>	<p>B x 64</p> <p>Ø6 x 35 mm</p>	<p>C x 24</p> <p>Ø6 x 30 mm</p>	<p>D x 64</p>	<p>E x 16</p> <p>Ø3.5 x 12 mm</p>
<p>F x 4</p>	<p>G x 14</p> <p>Ø5 x 40 mm</p>	<p>H x 66</p> <p>Ø3.5 x 14 mm</p>	<p>J x 8</p> <p>Ø3.5 x 20 mm</p>	<p>K x 4</p>
<p>L x 4</p>	<p>M x 12</p>	<p>N x 12</p> <p>Ø3 x 14 mm</p>	<p>P x 2</p>	<p>Q x 2</p>
<p>R x 4</p> <p>R-1 R-2 300 mm</p>	<p>S x 2</p> <p>Ø3.5 x 35 mm</p>	<p>T x 2</p>	<p>U x 4</p>	<p>V x 4</p>

Parts List

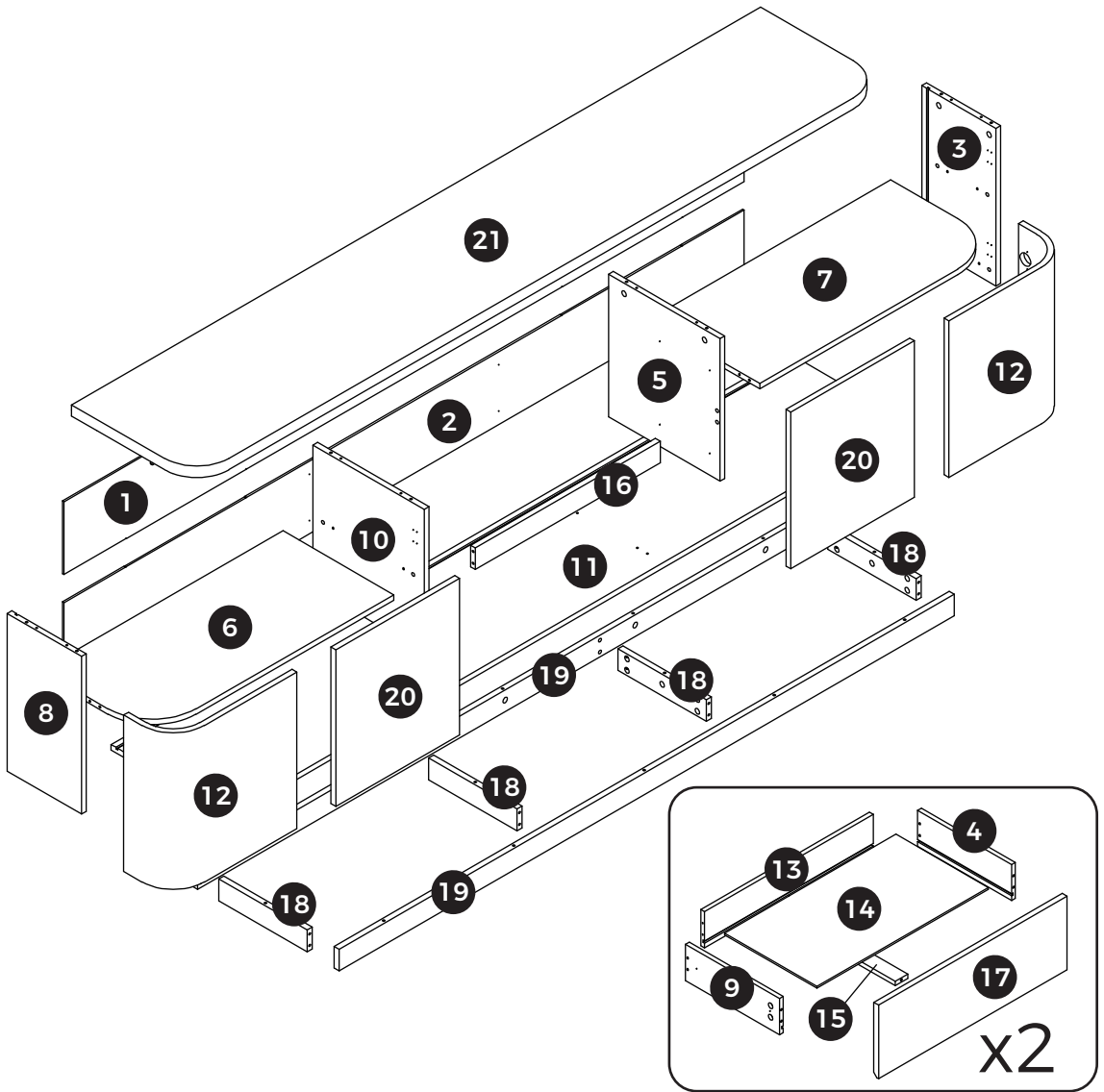

WARNING

Children have died from furniture tipover. To reduce the risk of furniture tipover:

- ALWAYS install Anti-tip device provided
- NEVER put a TV on this product.
- NEVER allow children to stand, climb or hang on drawers, doors, or shelves.
- NEVER open more than one drawer at a time.
- Place heaviest items in the lowest drawers.

This is a permanent label. Do not remove!



90 MINUTES



2 ADULTS



INTERMEDIATE

The parts listed above are required for proper assembly. If there are any issues. Contact us: customerservice@homsee.com

Lista de Piezas

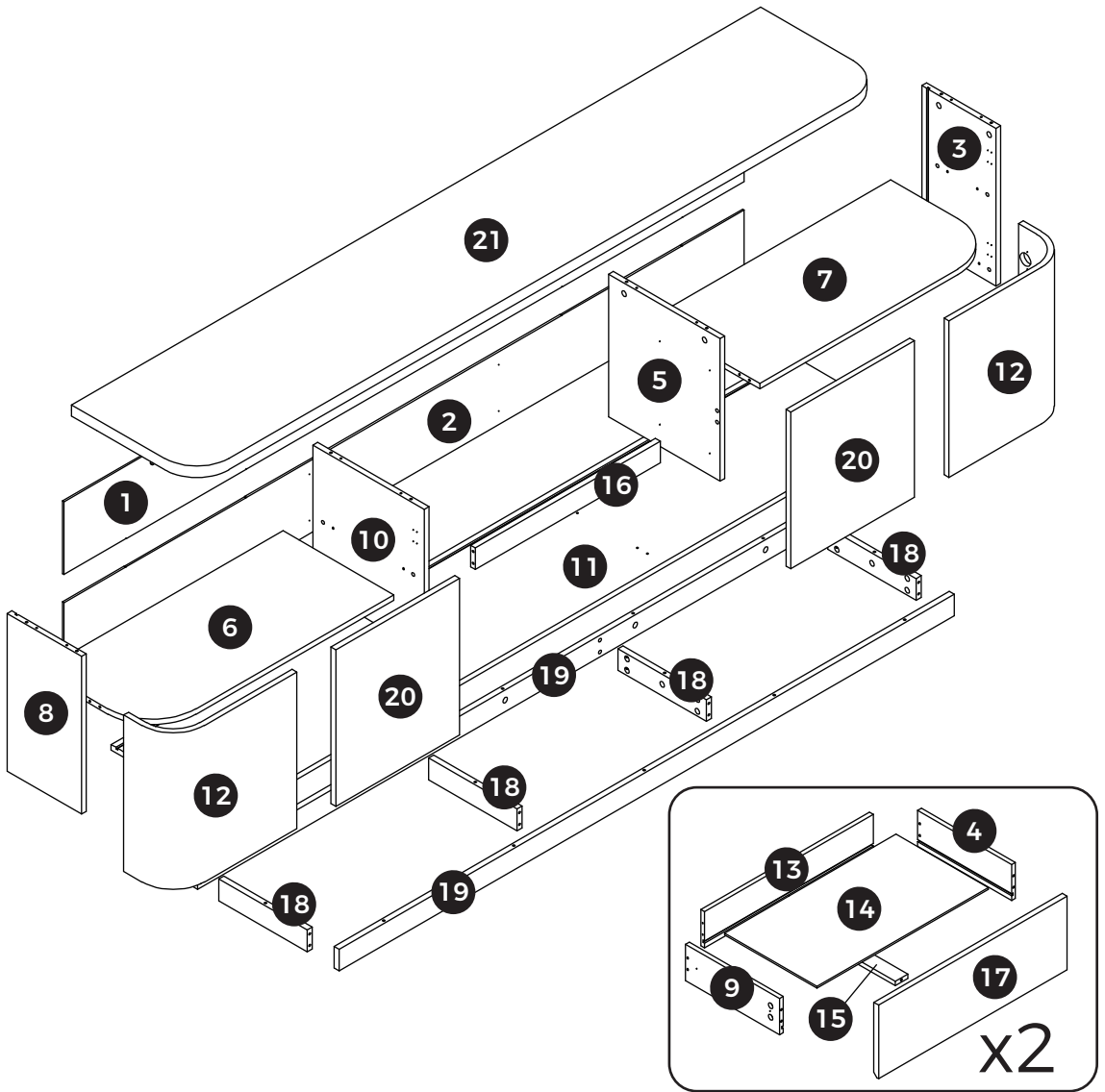

⚠ ADVERTENCIA

Los niños han muerto por el vuelco de muebles. Para reducir el riesgo de que el mueble se vuelque:

- SIEMPRE instala el dispositivo antivuelco incluido.
- NUNCA coloques un televisor sobre este producto.
- NUNCA permitas que los niños se suban, trepen o cuelguen de los cajones, puertas o estantes.
- NUNCA abras más de un cajón a la vez.
- Coloca los objetos más pesados en los cajones inferiores.

Esta es una etiqueta permanente. ¡No la retires!



90 MINUTOS



2 ADULTOS



INTERMEDIO

Las piezas enumeradas arriba son necesarias para un montaje correcto. Si tienes algún problema, contáctanos en: customerservice@homsee.com

01

[EN] Please note that this step is required for the following assembly steps.

Insert the pre-installed fitting (D) into the hole and ensure it is fully seated and flush with the panel surface.
Screw the cam bolt (B) vertically into fitting (D) and tighten clockwise.

[ES] Tenga en cuenta que este paso es necesario para los siguientes pasos de montaje.

Inserte el herraje (D) en el orificio y asegúrese de que esté completamente asentado y al ras de la superficie del panel.
Enrosque el perno excéntrico (B) verticalmente en el herraje (D) y apriételo en el sentido de las agujas del reloj.

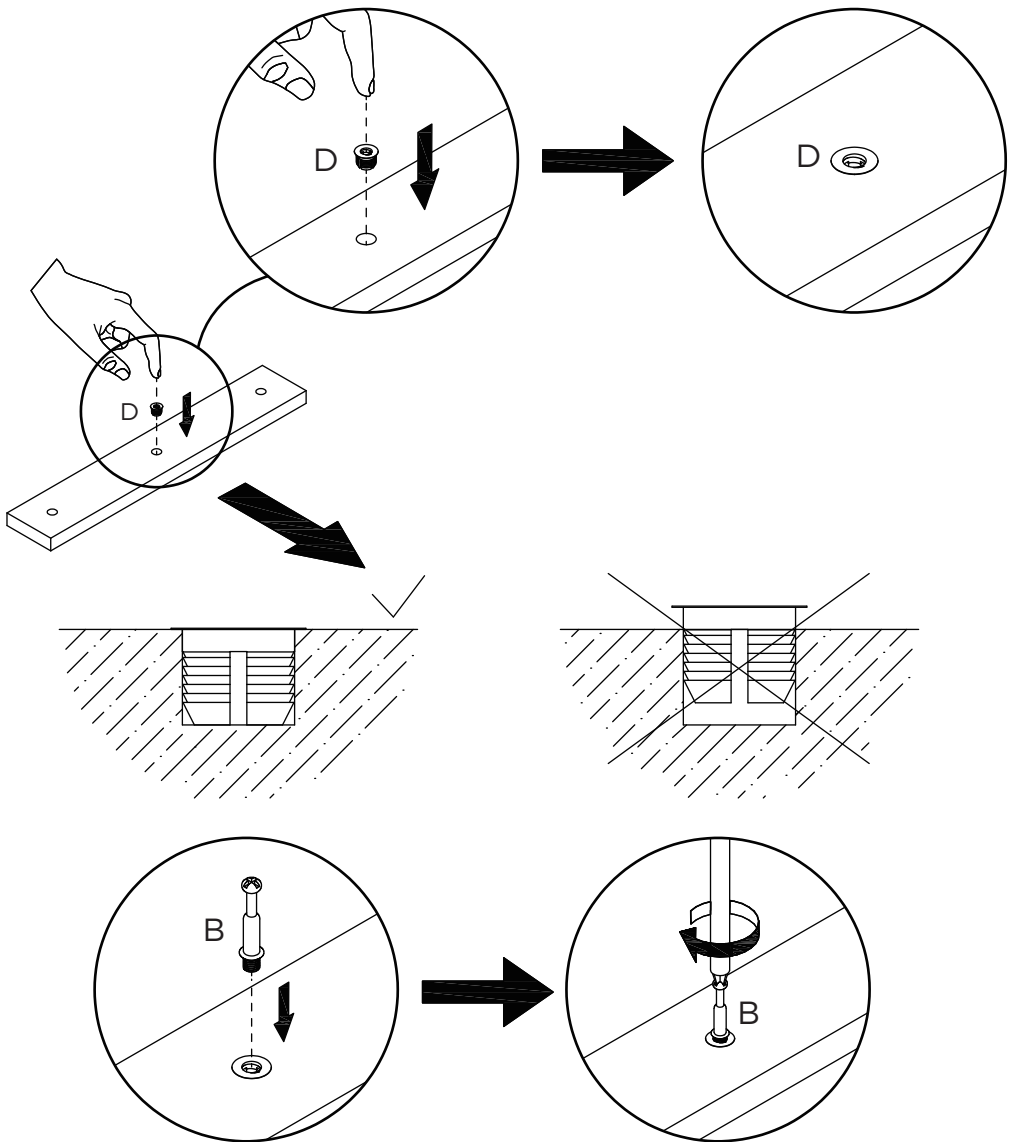

02

[EN] Locate the release lever on the inner side of slide rail R-1. Push the lever inward or upward with your finger, then pull slide rail R-2 outward to detach it.

[ES] Localice la palanca de liberación en el lado interior de la guía R-1. Empuje la palanca hacia adentro o hacia arriba con el dedo y luego tire de la guía R-2 hacia afuera para separarla.

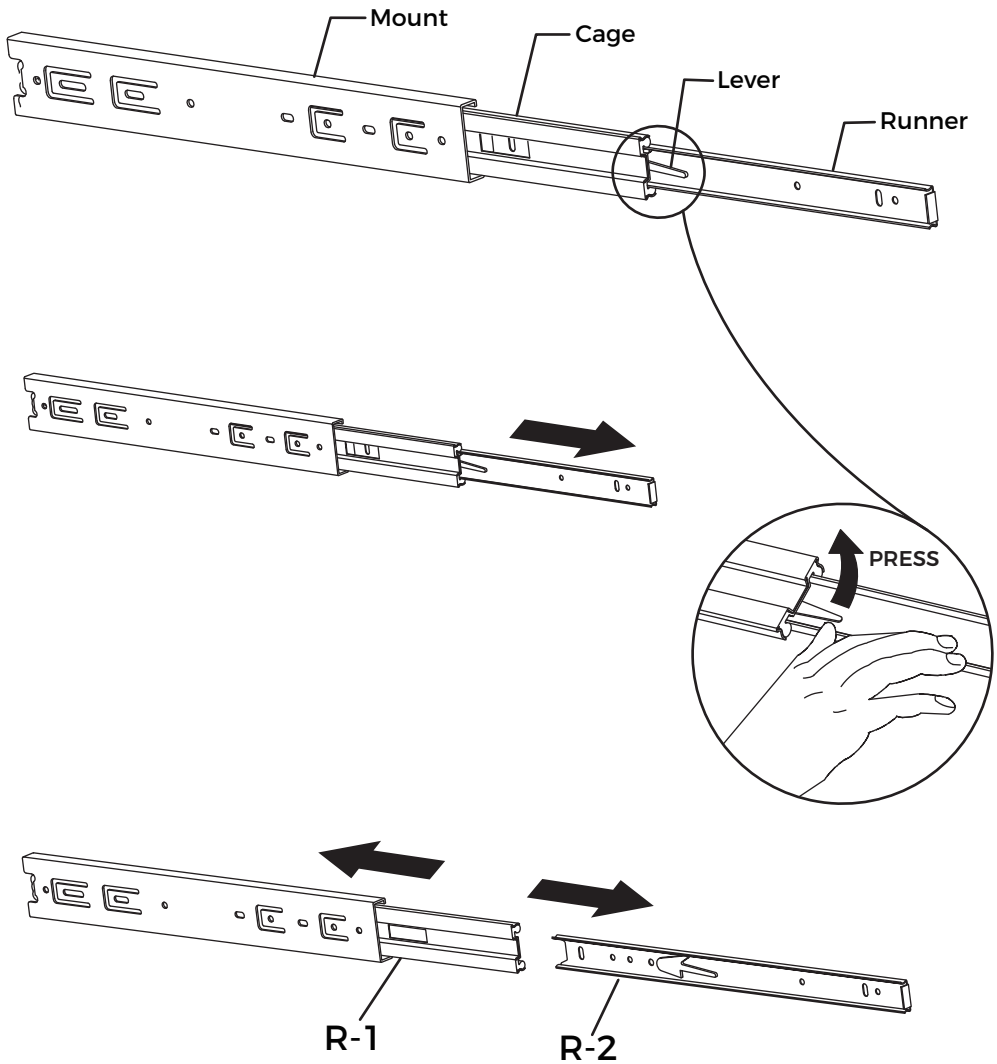

03

[EN] Push the damper release lever inward or upward to retract the damper.

[ES] Empuje la palanca de liberación del amortiguador hacia adentro o hacia arriba para retraer el amortiguador.

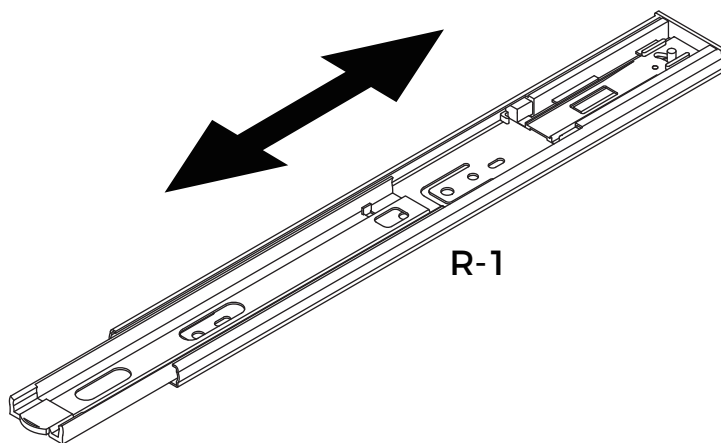
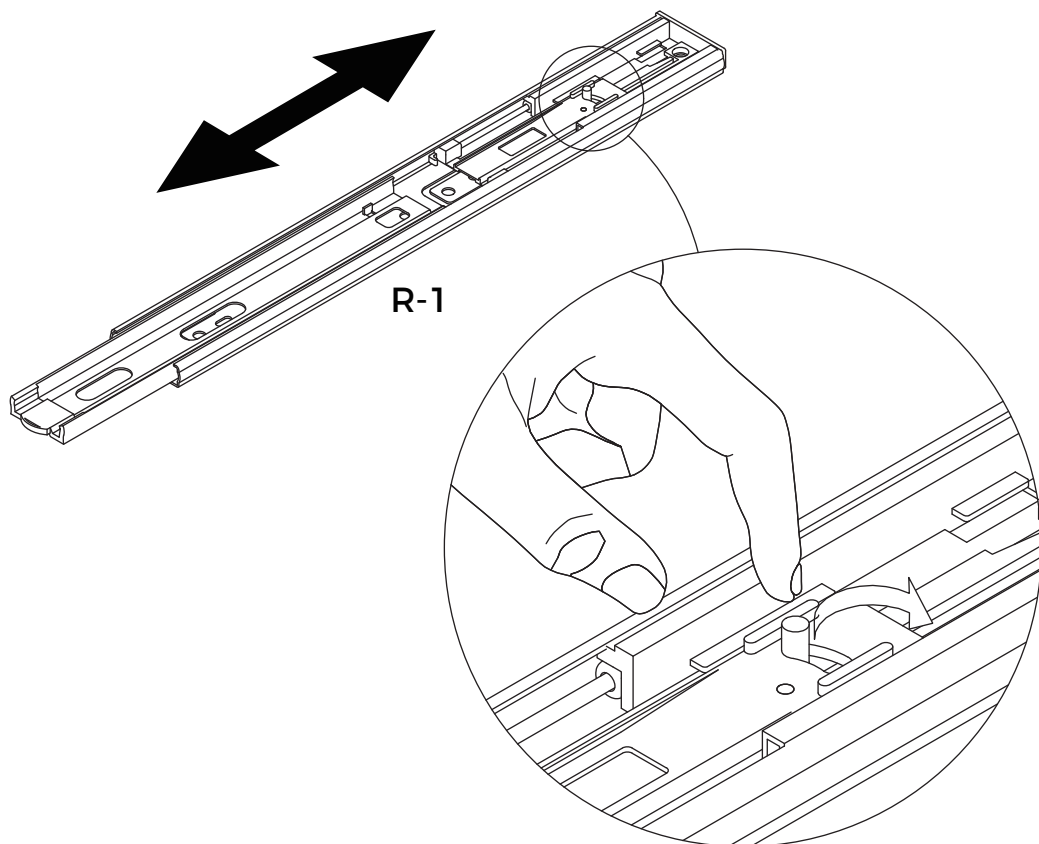

04

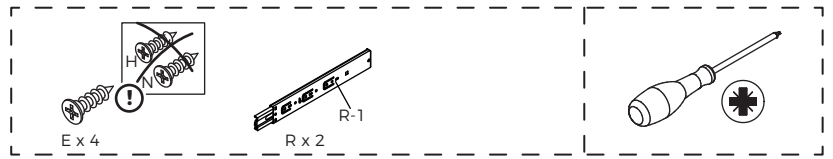

[EN] Secure slide rail R (R-1) to panel 10 with screw (E).

[ES] Fije el riel deslizante R (R-1) al panel 10 usando el tornillo (E).

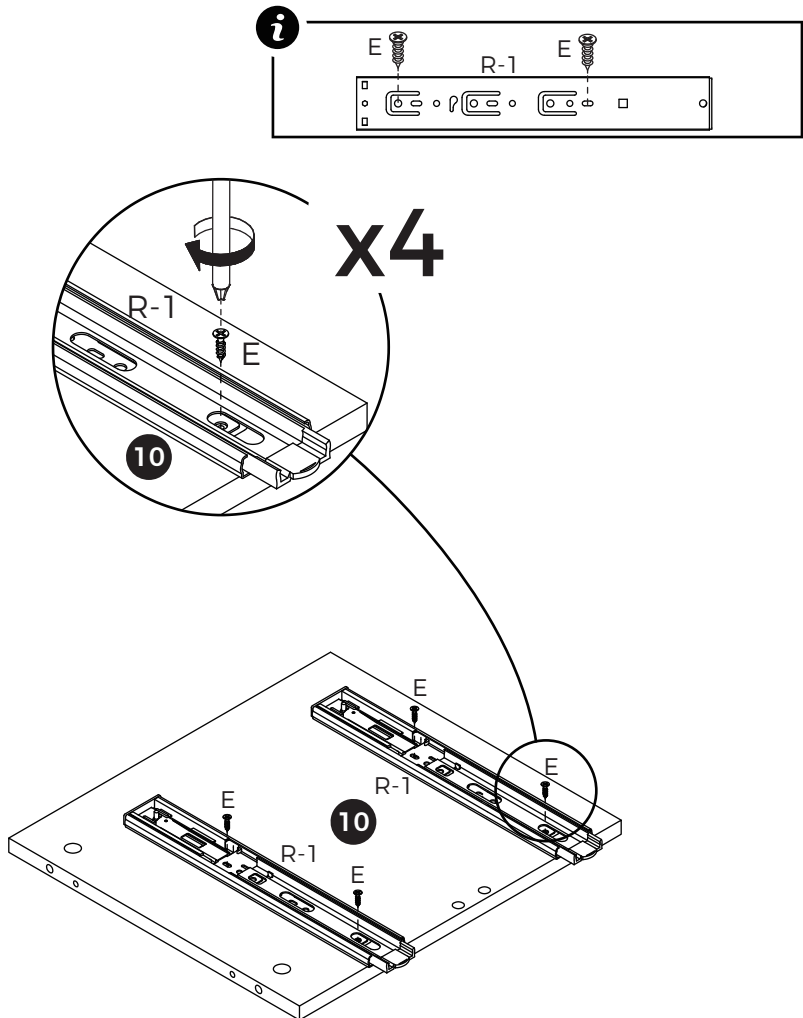

06

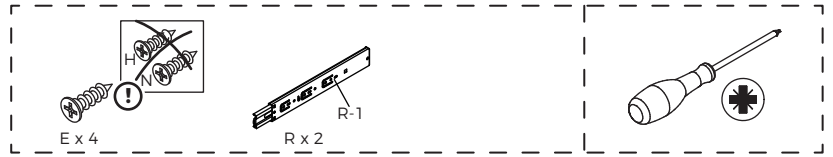

[EN] Secure slide rail R (R-1) to panel 5 using screw (E).

[ES] Fije el riel deslizante R (R-1) al panel 5 usando el tornillo (E).

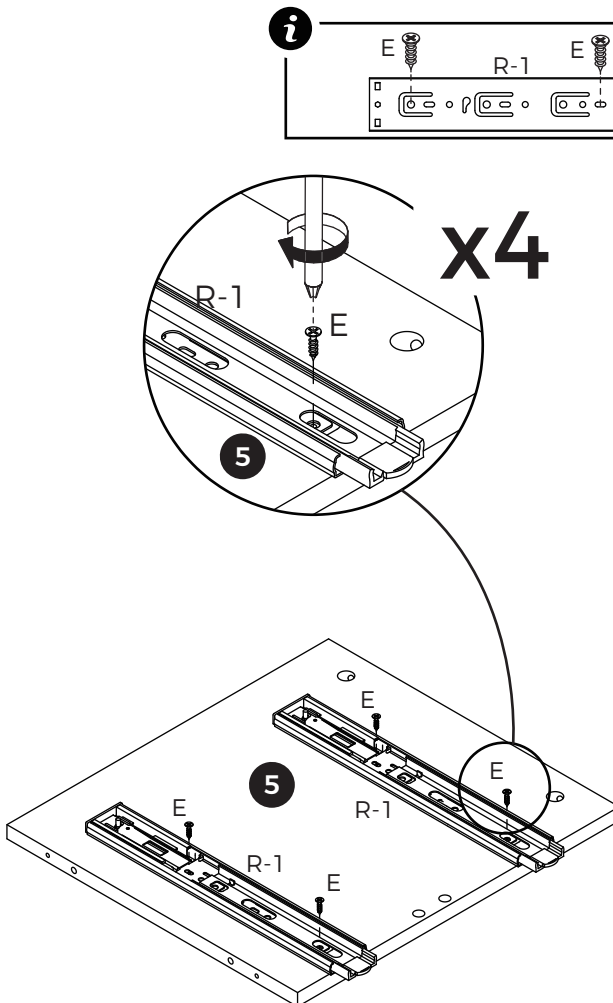

07



[EN] Install plug (D), then screw the self-tapping rod (B) onto panel 5.

[ES] Instale el tapón (D) y luego enrosque la varilla autorroscante (B) en el panel 5.

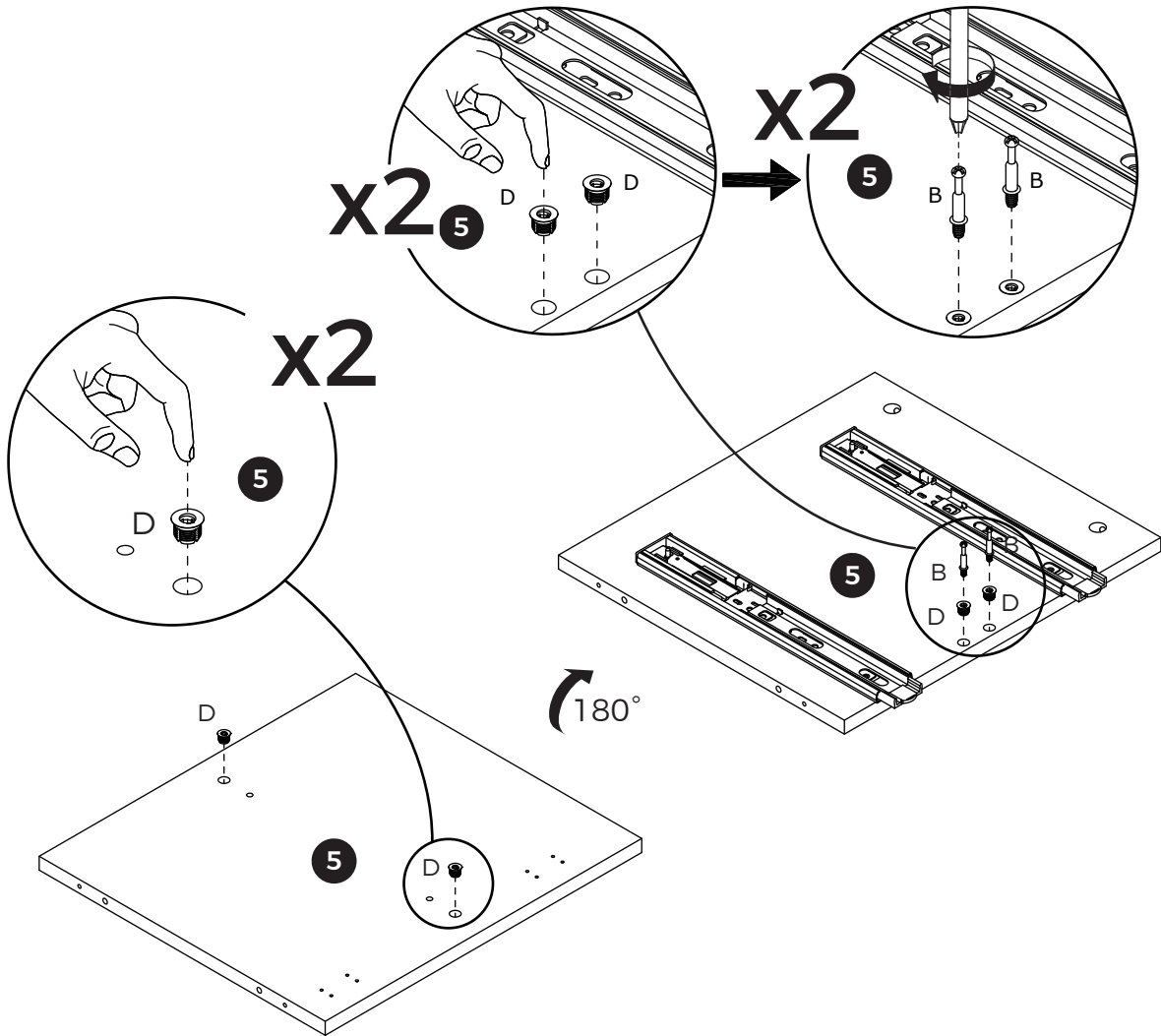

08



[EN] Connect panel 16 to panel 10, then tighten the eccentric wheel (A) clockwise as shown.

[ES] Conecte el panel 16 al panel 10 y luego apriete la rueda excéntrica (A) en el sentido de las agujas del reloj, como se muestra.

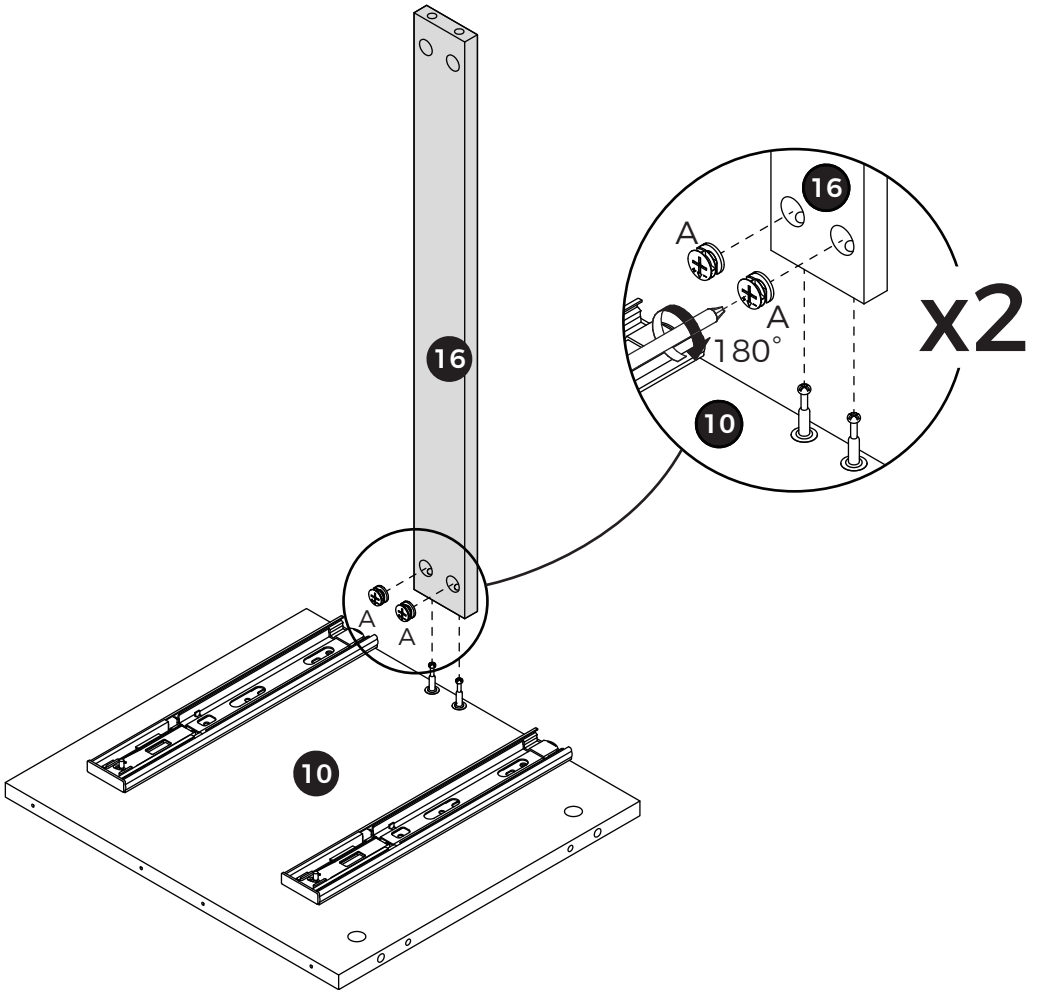

09



[EN] Connect panel 5 to panel 16, then tighten the eccentric wheel (A) clockwise as shown. **(Place the foam boards that come with the package under panels 5 and 10 to prevent panel 16 from falling and cracking the holes.)**

[ES] Conecte el panel 5 al panel 16 y luego apriete la rueda excéntrica (A) en el sentido de las agujas del reloj, como se muestra. **(Coloque las placas de espuma incluidas en el paquete debajo de los paneles 5 y 10 para evitar que el panel 16 se caiga y agriete los orificios.)**

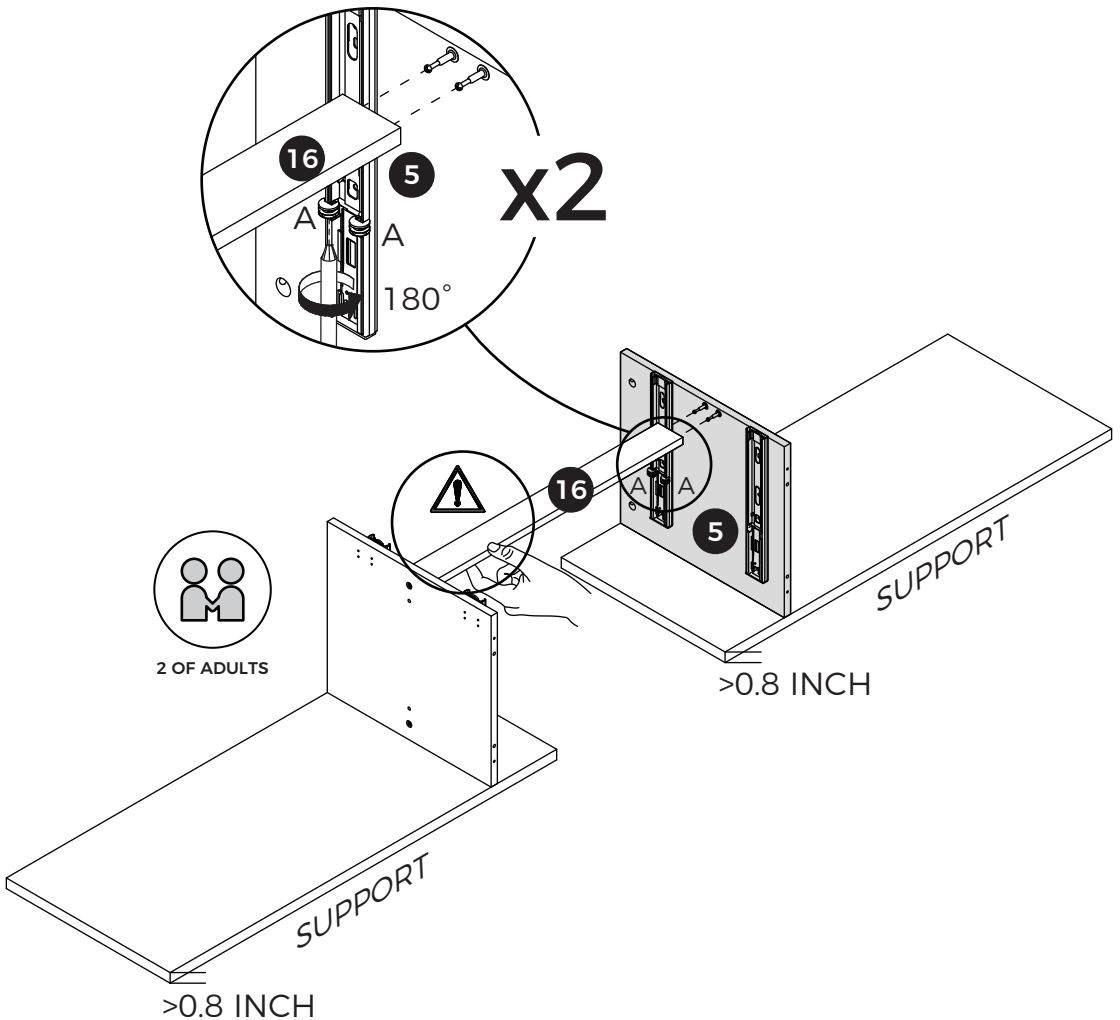

10



[EN] Screw the self-tapping rod (B) onto panels 5 and 10.

[ES] Enrosque la varilla autorroscante (B) en los paneles 5 y 10.

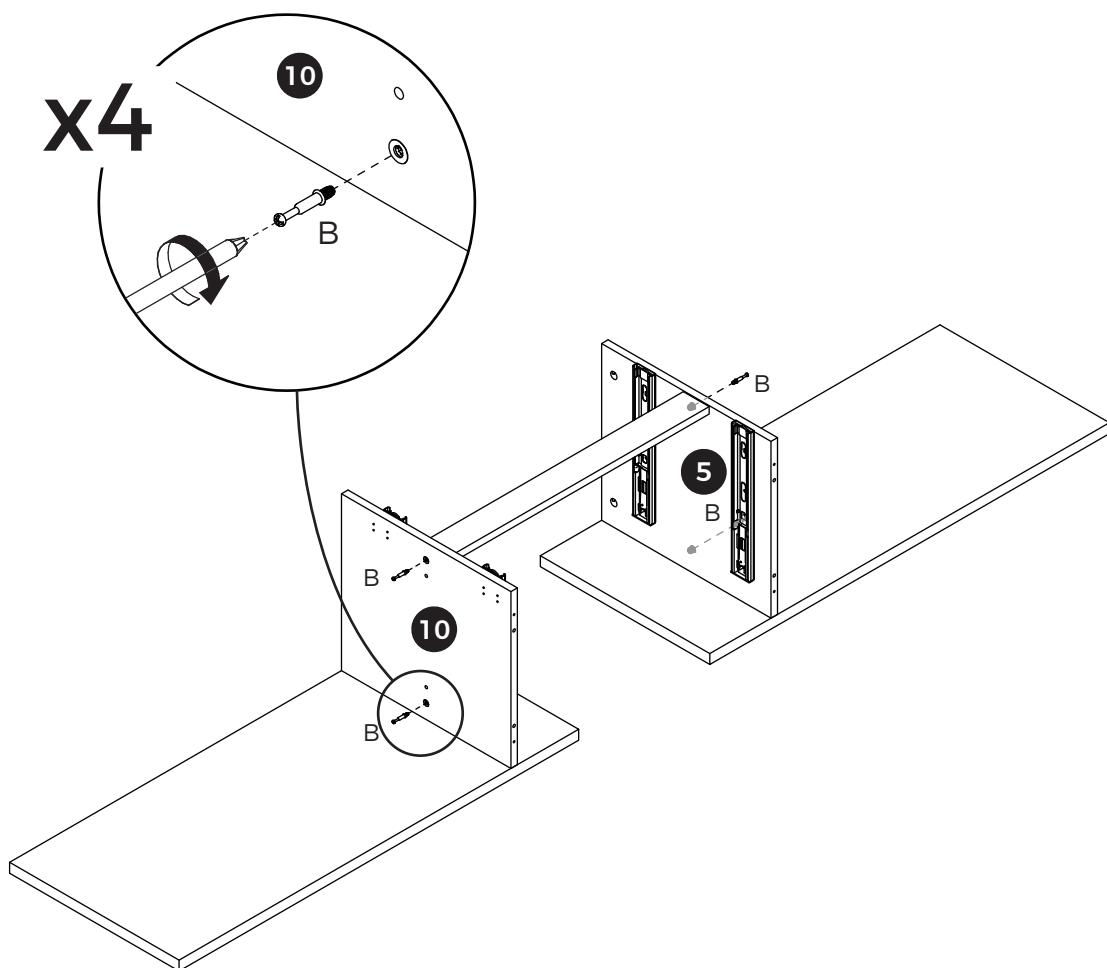

11



[EN] Connect panel 6 to panel 10 and panel 7 to panel 5 using wooden dowel (C), then tighten the eccentric wheel (A) clockwise as shown.

[ES] Conecte el panel 6 al panel 10 y el panel 7 al panel 5 usando el espigo de madera (C), y luego apriete la rueda excéntrica (A) en el sentido de las agujas del reloj, como se muestra.

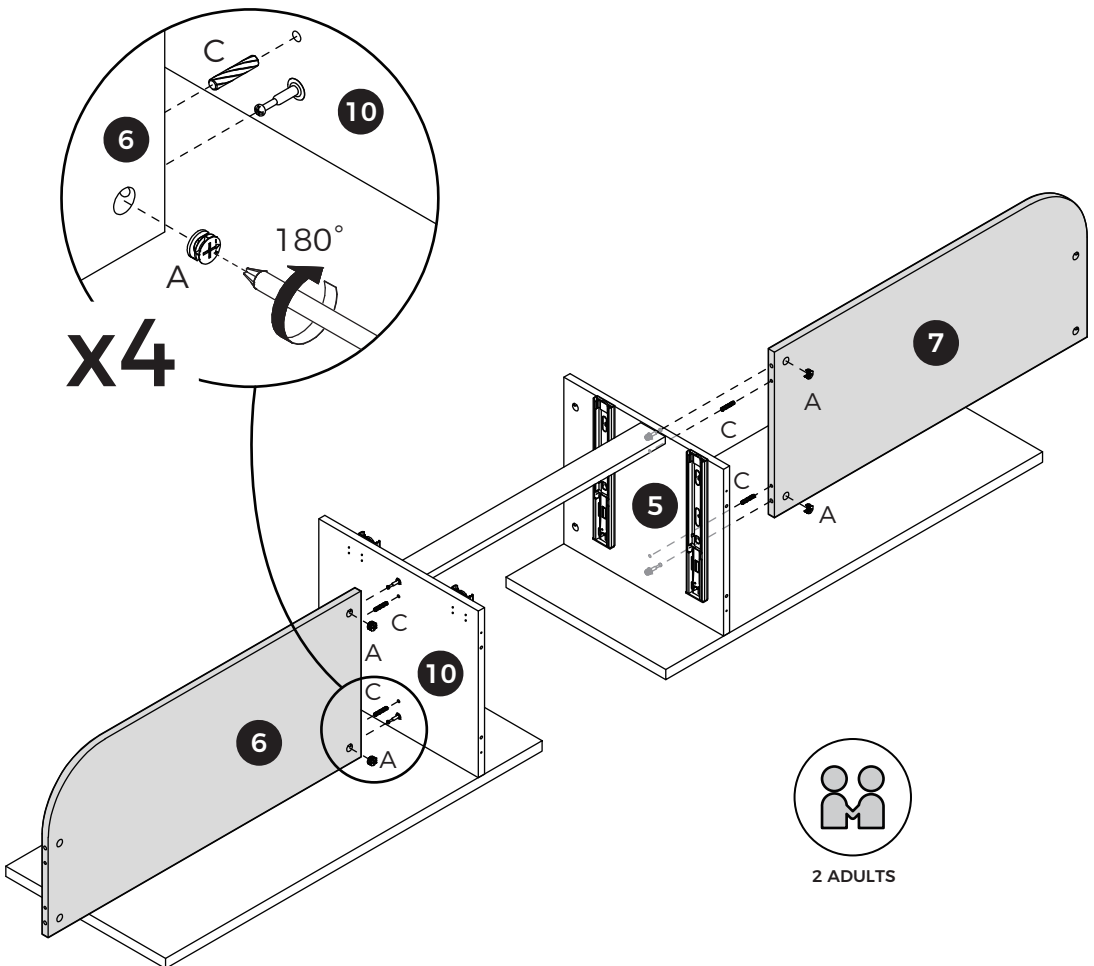

12



[EN] Install plug (D), then screw the self-tapping rod (B) onto panel 11.

[ES] Instale el tapón (D) y luego enrosque la varilla autorroscante (B) en el panel 11.

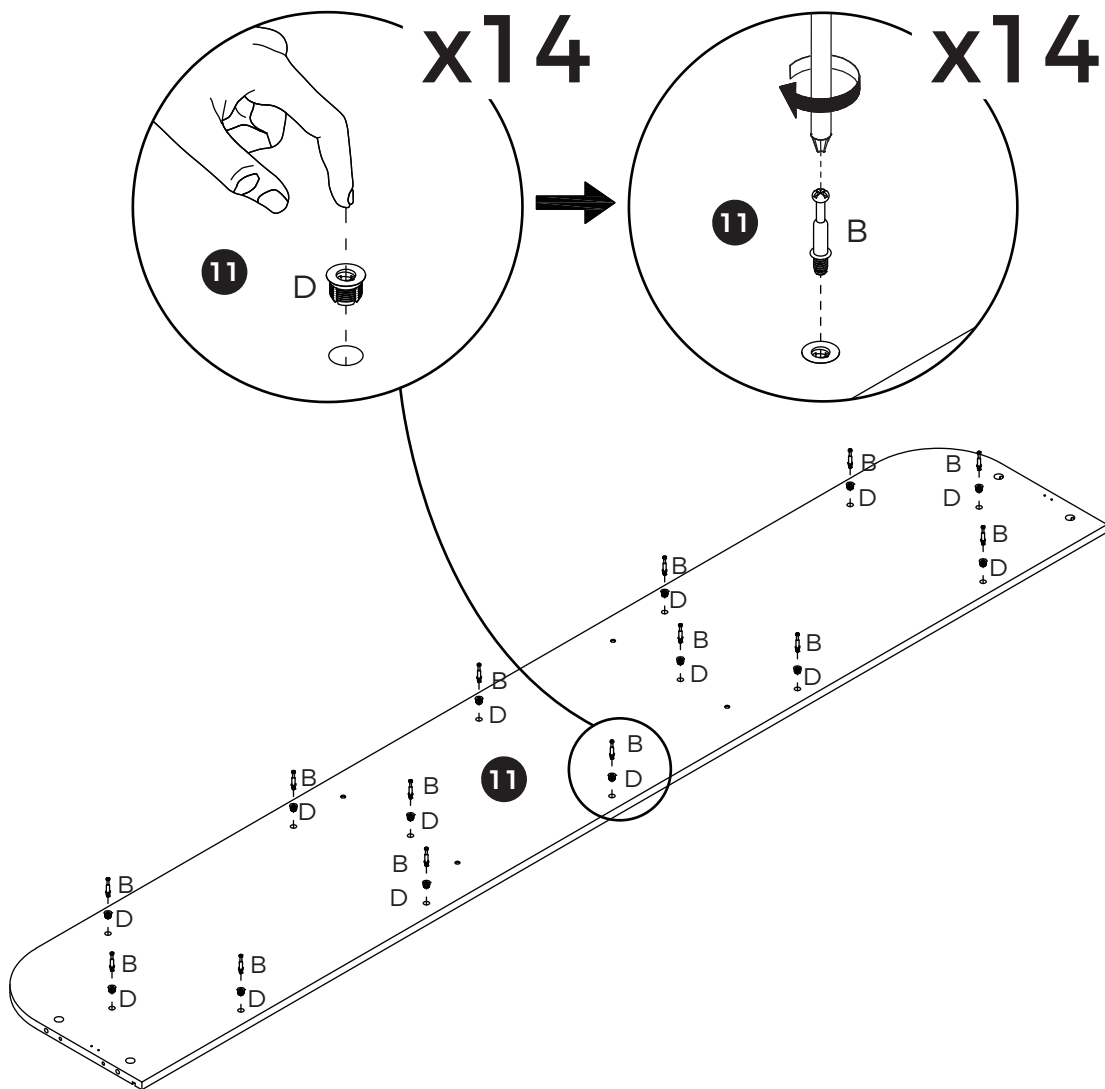

13



[EN] Connect panel 11 to panels 5 and 10 using wooden dowel (C), and secure them with screws (G).

[ES] Conecte el panel 11 a los paneles 5 y 10 usando el espigo de madera (C) y asegúrelos con los tornillos (G).

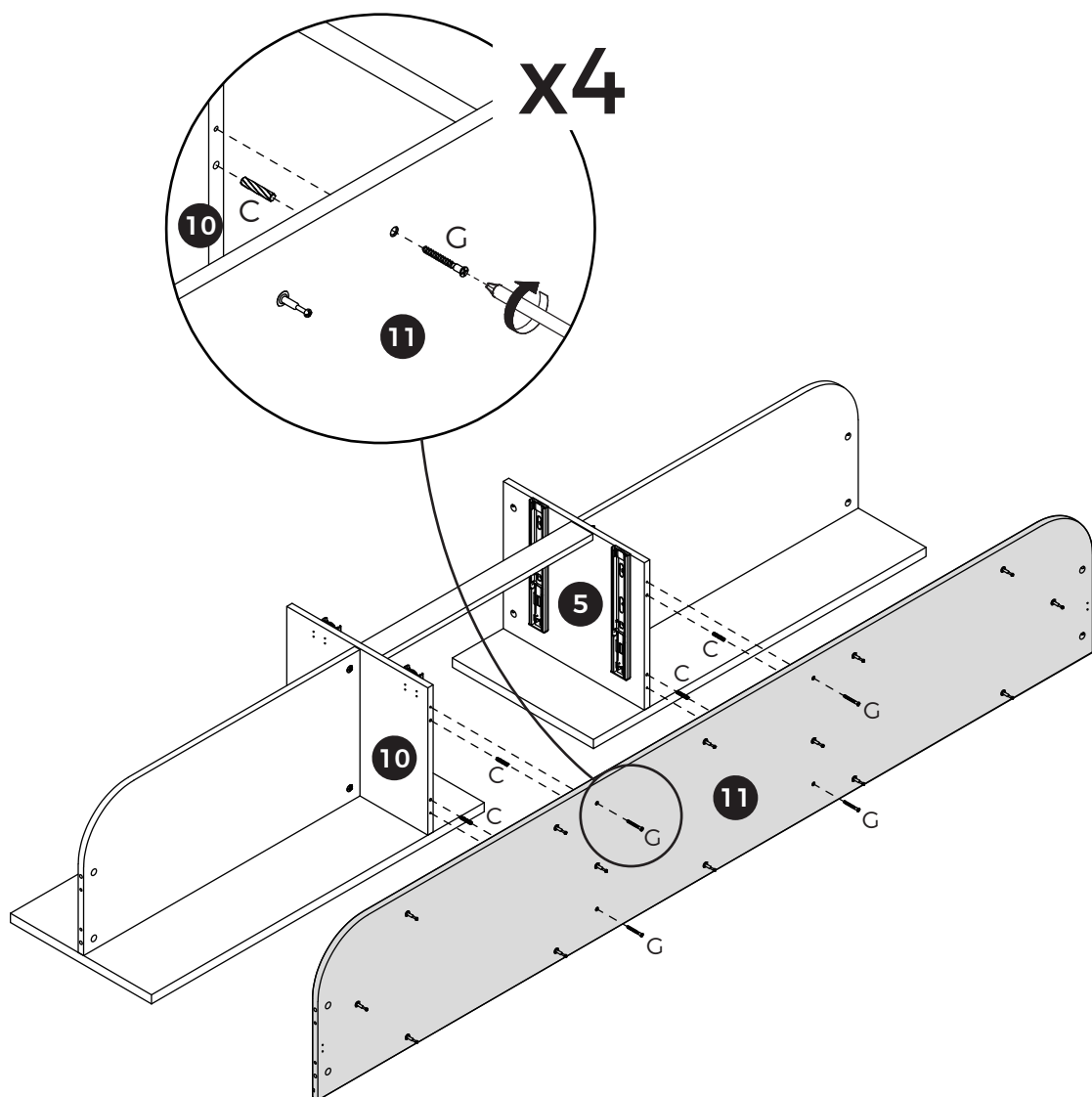

14

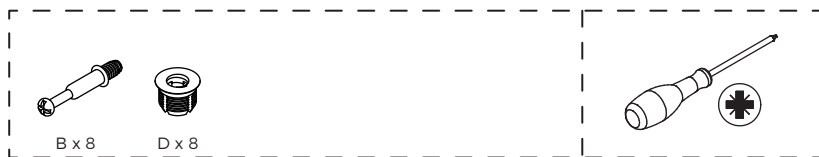

[EN] Install plug (D), then screw the self-tapping rod (B) onto panels 3 and 8.

[ES] Instale el tapón (D) y luego enrosque la varilla autorroscante (B) en los paneles 3 y 8.

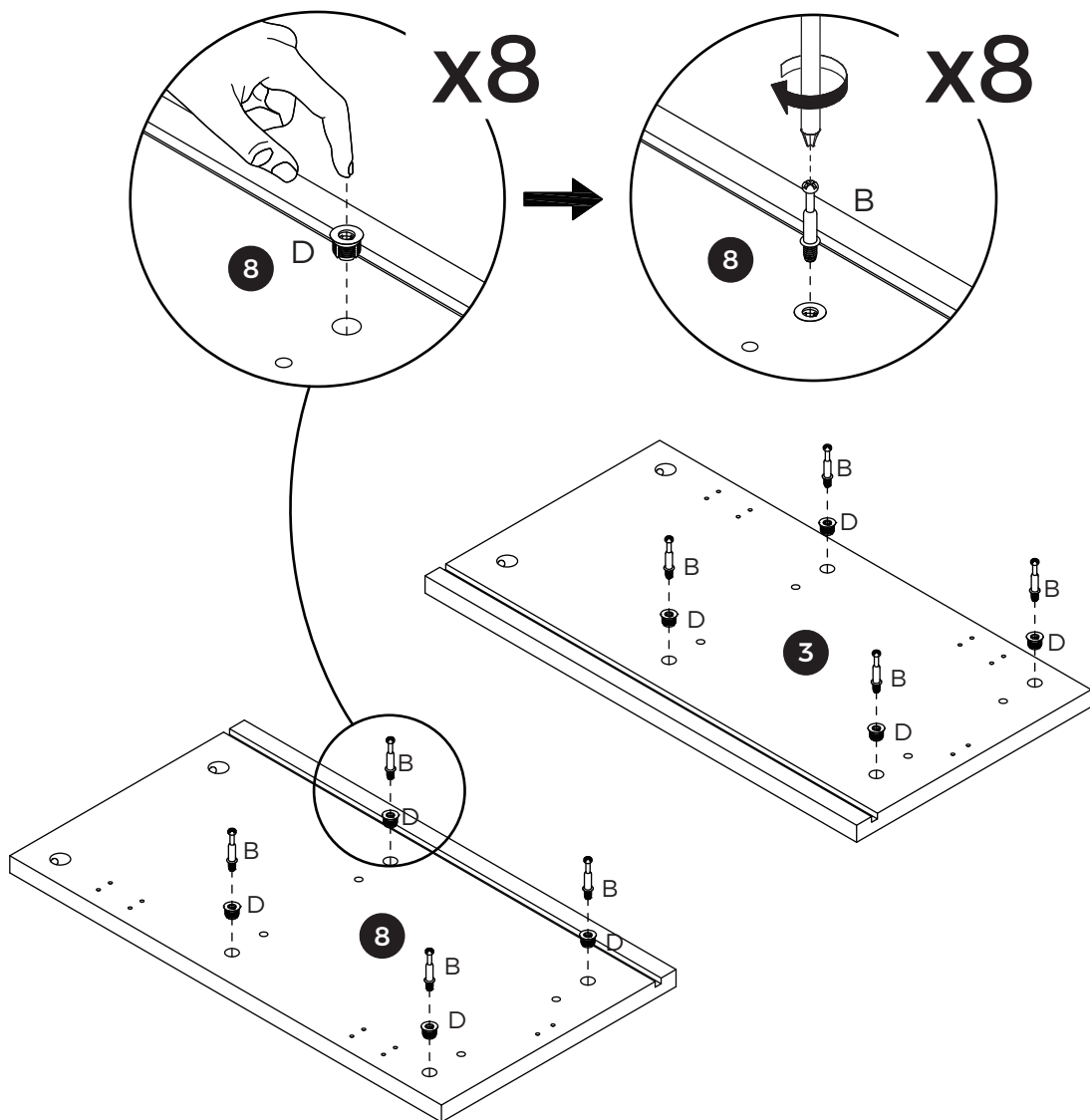

15



[EN] Connect panels 3 and 8 to panels 6, 7 and 11 using wooden dowels (C), then tighten by turning eccentric wheel (A) clockwise as shown.

[ES] Conecte los paneles 3 y 8 con los paneles 6, 7 y 11 usando los espigos de madera (C) y luego apriete girando la rueda excéntrica (A) en sentido horario, como se muestra.

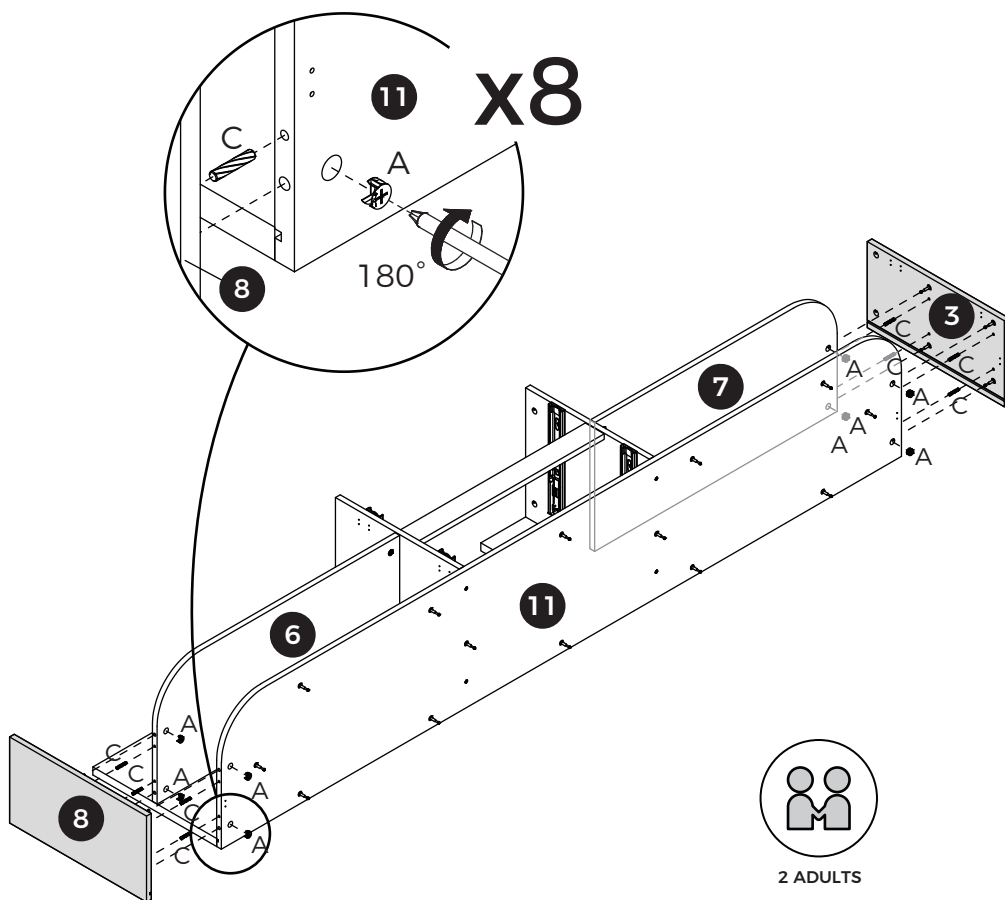

16



[EN] Secure component (Q) to panels 3, 8 and 11 using screw (H).

[ES] Fije el componente (Q) a los paneles 3, 8 y 11 usando el tornillo (H).

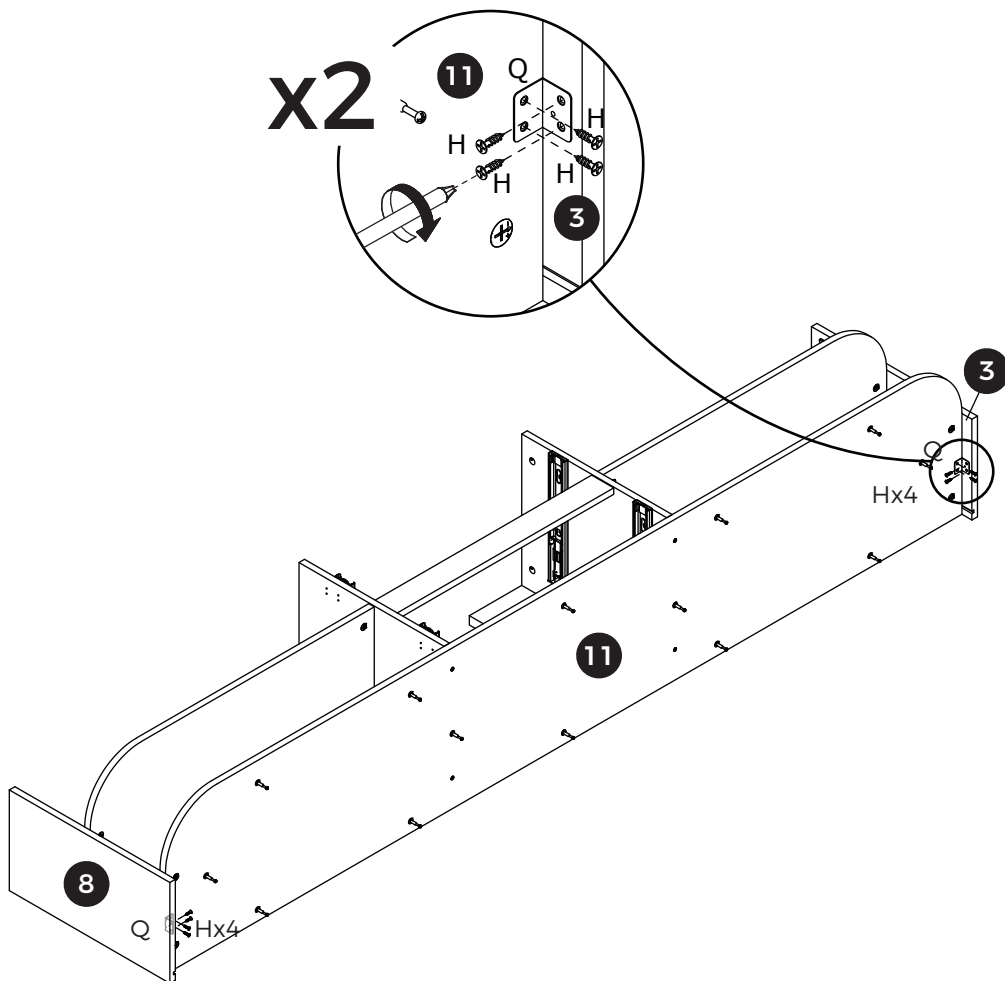

17



[EN] Install plug (D), then screw the self-tapping rod (B) onto panel 19.

[ES] Instale el tapón (D) y luego enrosque la varilla autorroscante (B) en el panel 19.

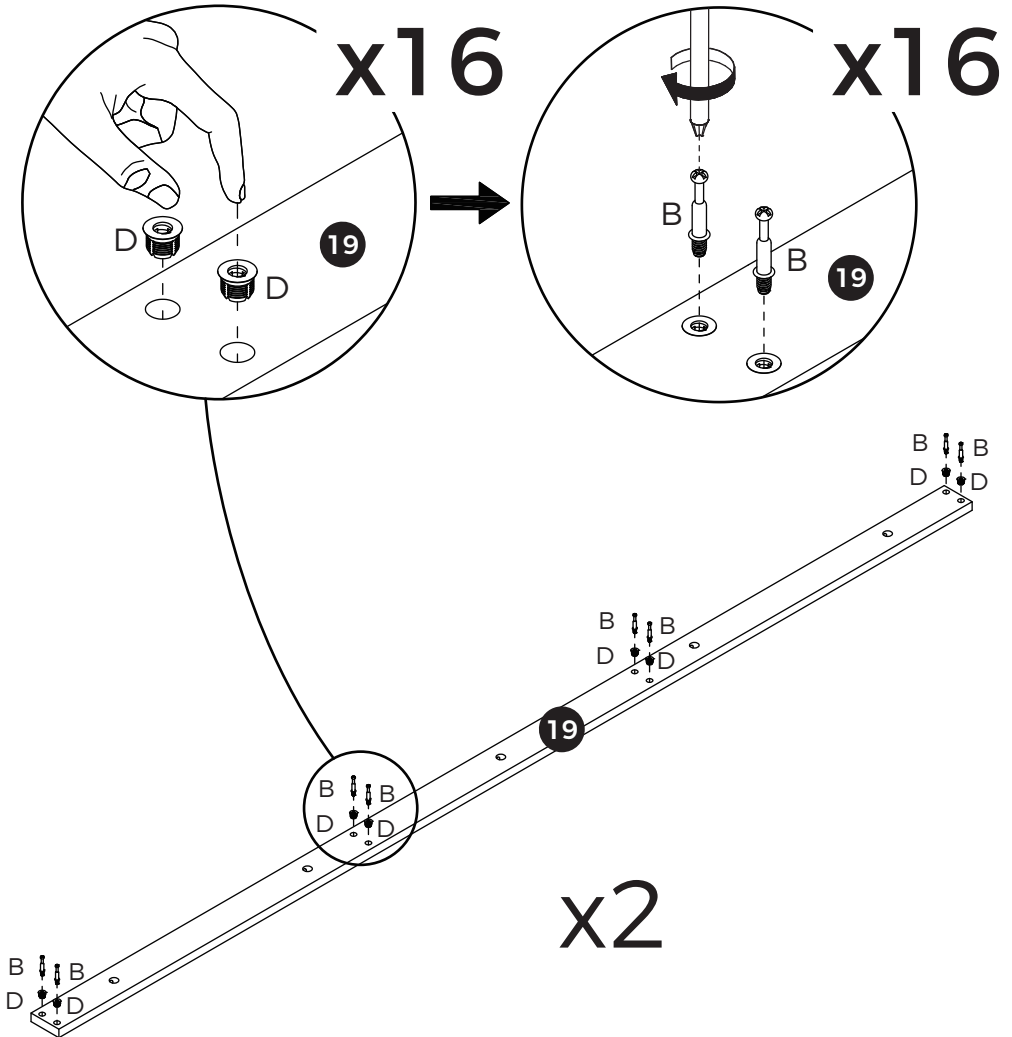

18



[EN] Connect panel 19 to panel 18, then tighten by turning eccentric wheel (A) clockwise as shown.

[ES] Conecte el panel 19 al panel 18 y luego apriete girando la rueda excéntrica (A) en sentido horario, como se muestra.

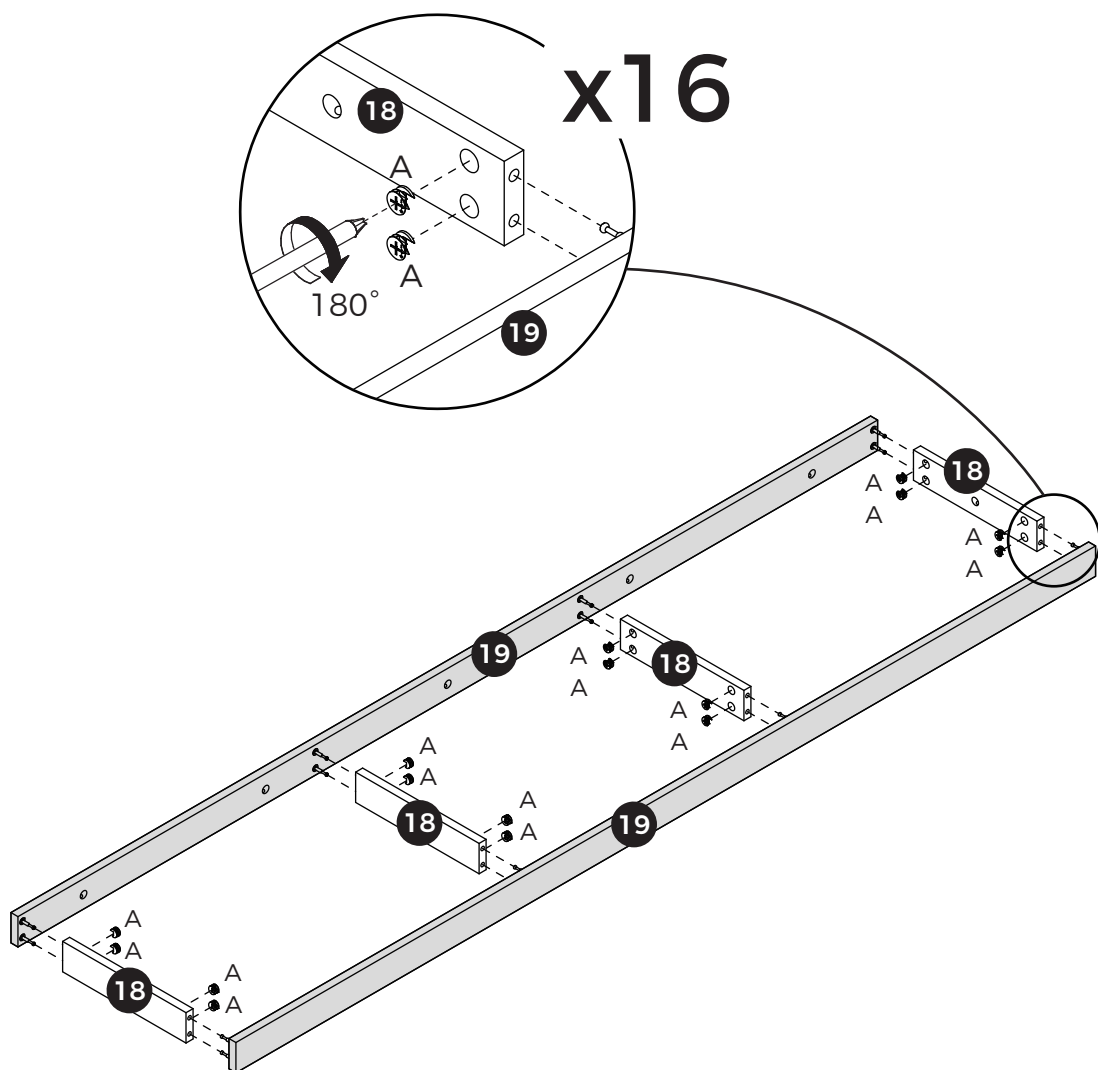

19



[EN] Connect panels 18 and 19 to panel 11, then tighten by turning eccentric wheel (A) clockwise as shown.

[ES] Conecte los paneles 18 y 19 al panel 11 y luego apriete girando la rueda excéntrica (A) en sentido horario, como se muestra.

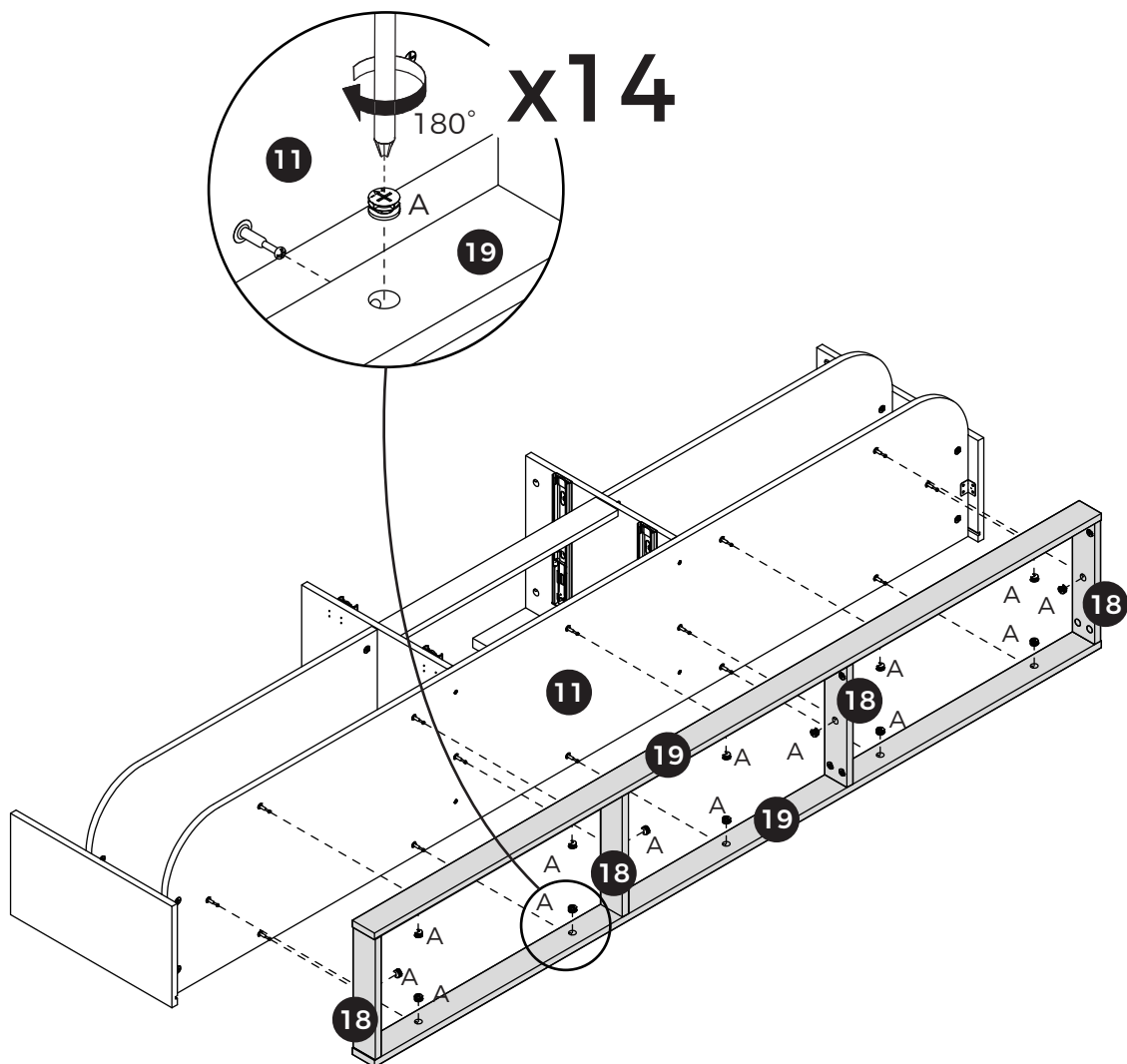

20

[EN] Insert panels 1 and 2 into the available slots.

[ES] Inserte los paneles 1 y 2 en las ranuras disponibles.

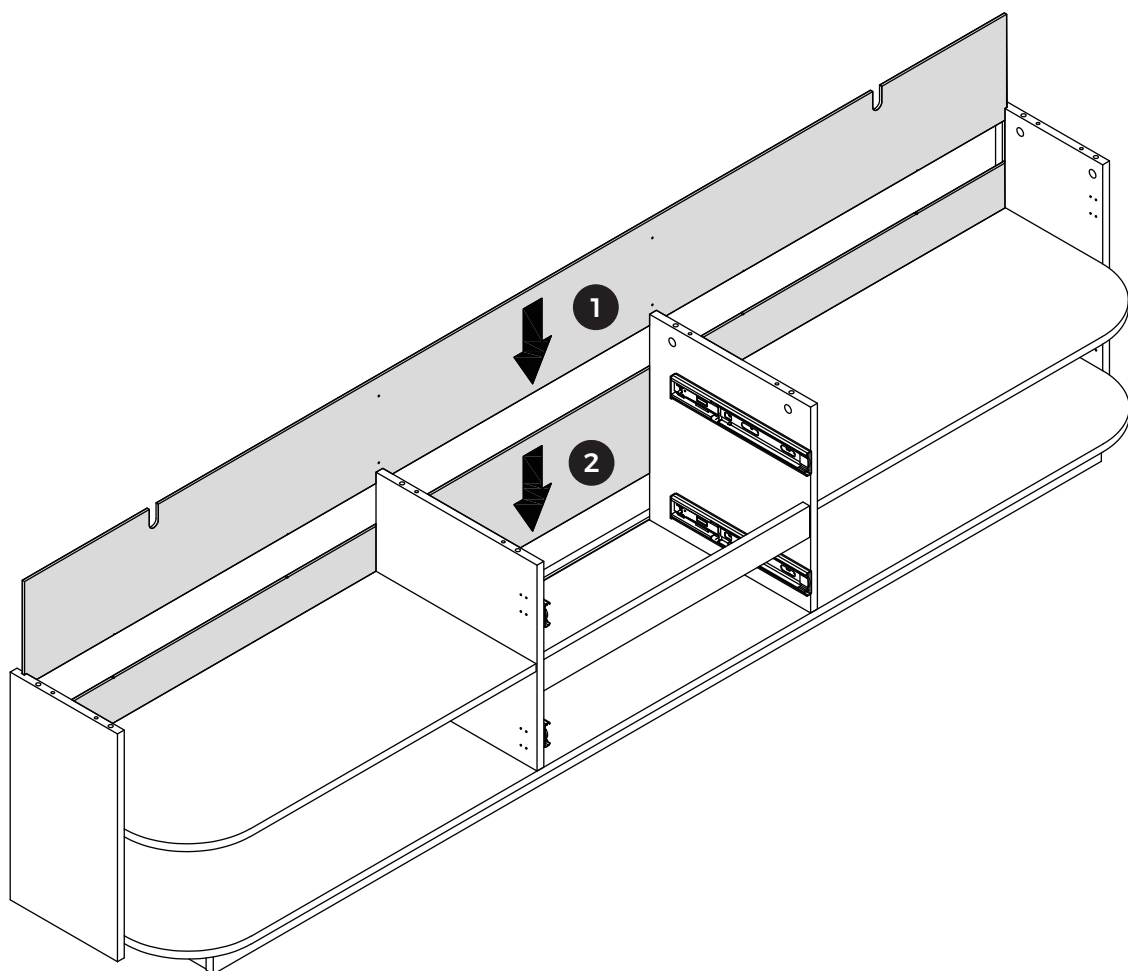



[EN] Install plug (D), then screw the self-tapping rod (B) onto panel 21.

[ES] Instale el tapón (D) y luego enrosque la varilla autorroscante (B) en el panel 21.

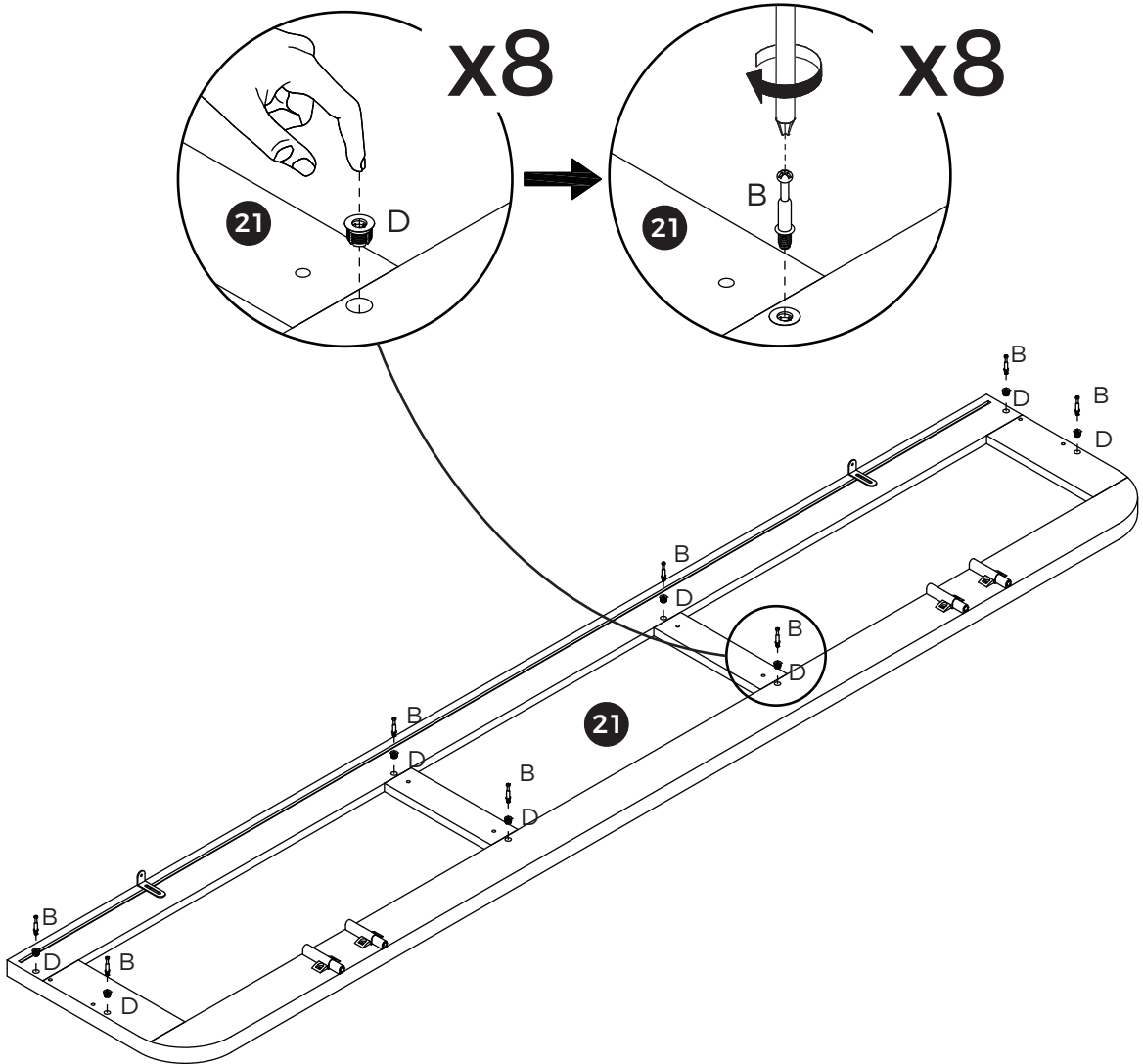

23



[EN] Insert wooden dowels (C) into panels 3, 5, 8 and 10.

[ES] Inserte los espigos de madera (C) en los paneles 3, 5, 8 y 10.

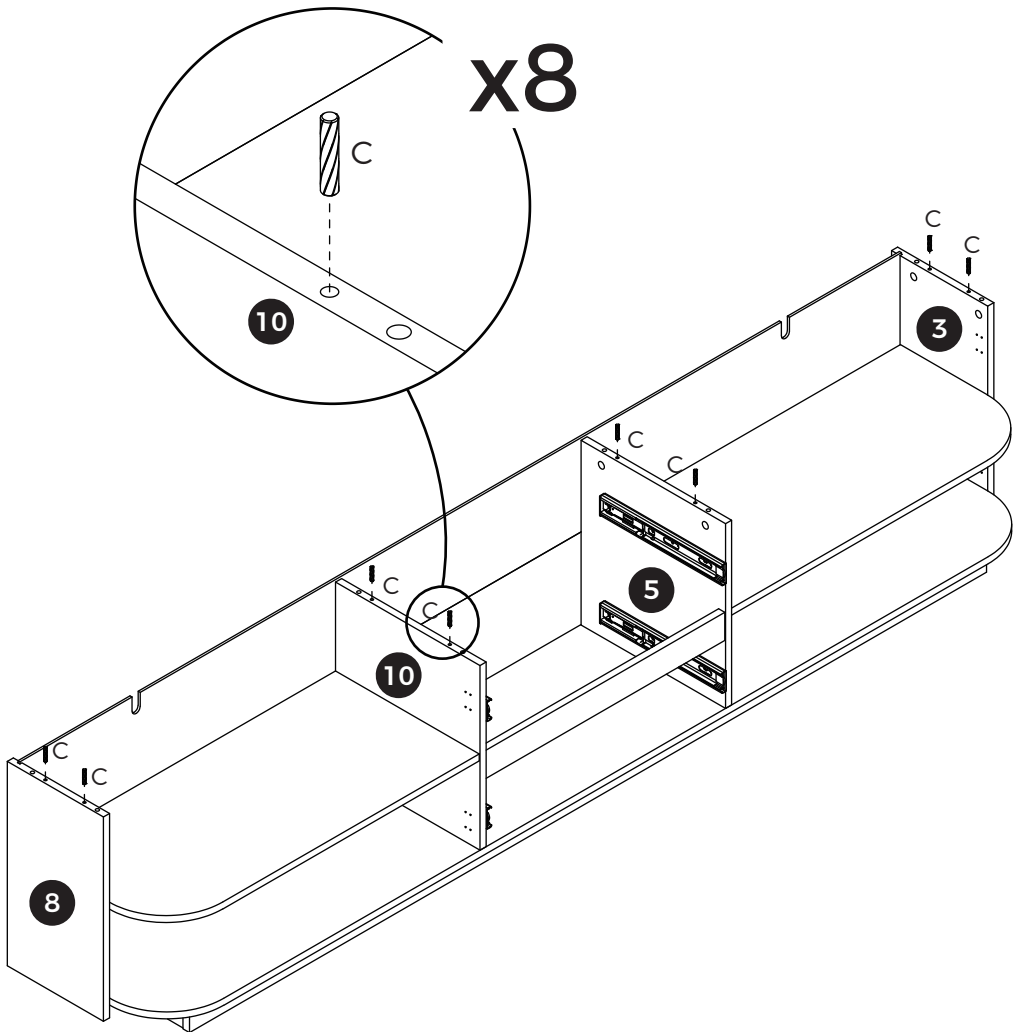

24



[EN] Connect panel 21 to panels 3, 5, 8 and 10, then tighten by turning eccentric wheel (A) clockwise as shown.

[ES] Conecte el panel 21 con los paneles 3, 5, 8 y 10, y luego apriete girando la rueda excéntrica (A) en sentido horario, como se muestra.

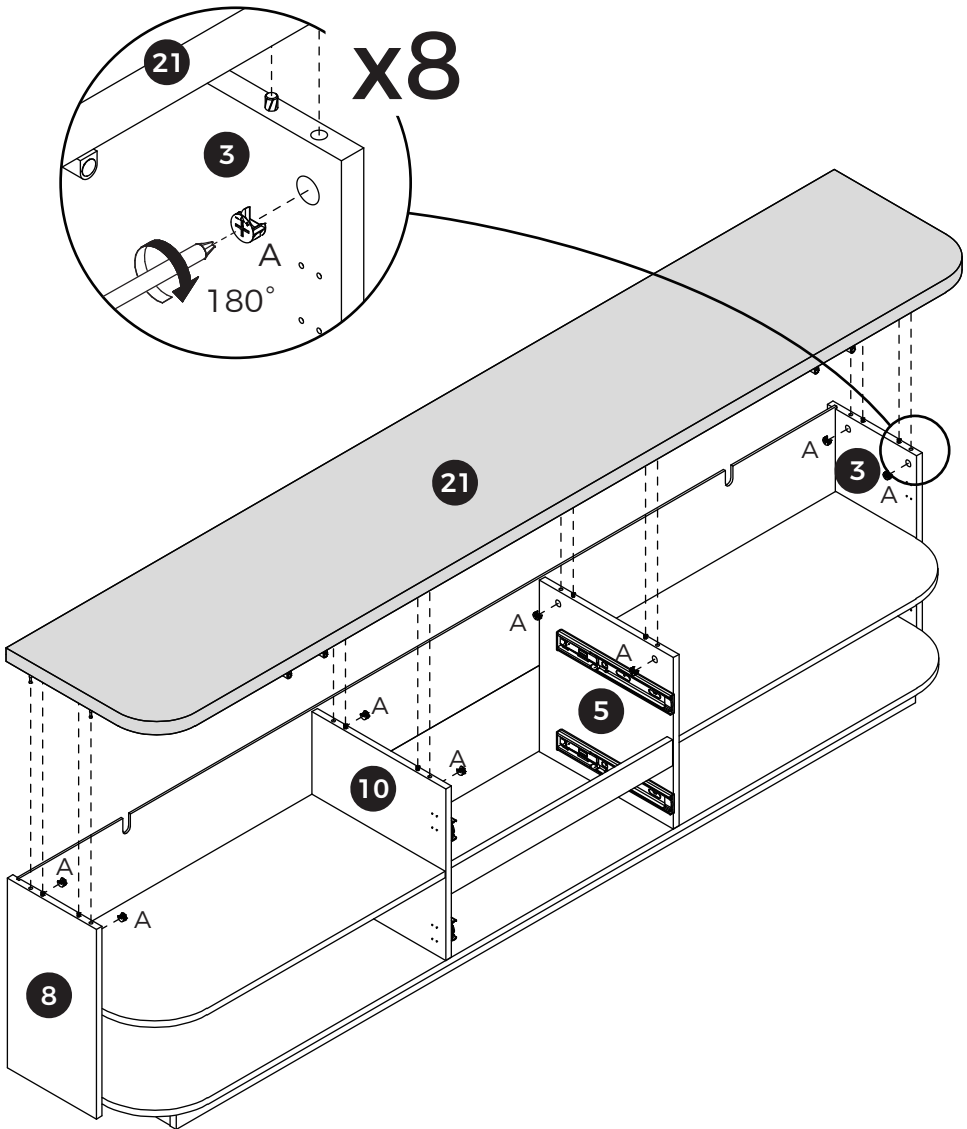

26



[EN] Secure panels 1 and 2 to panels 5 and 10 using screws (J).
Secure component (V) to panels 1 and 2 using screws (U).

[ES] Fije los paneles 1 y 2 a los paneles 5 y 10 usando los tornillos (J).
Fije el componente (V) a los paneles 1 y 2 usando los tornillos (U).

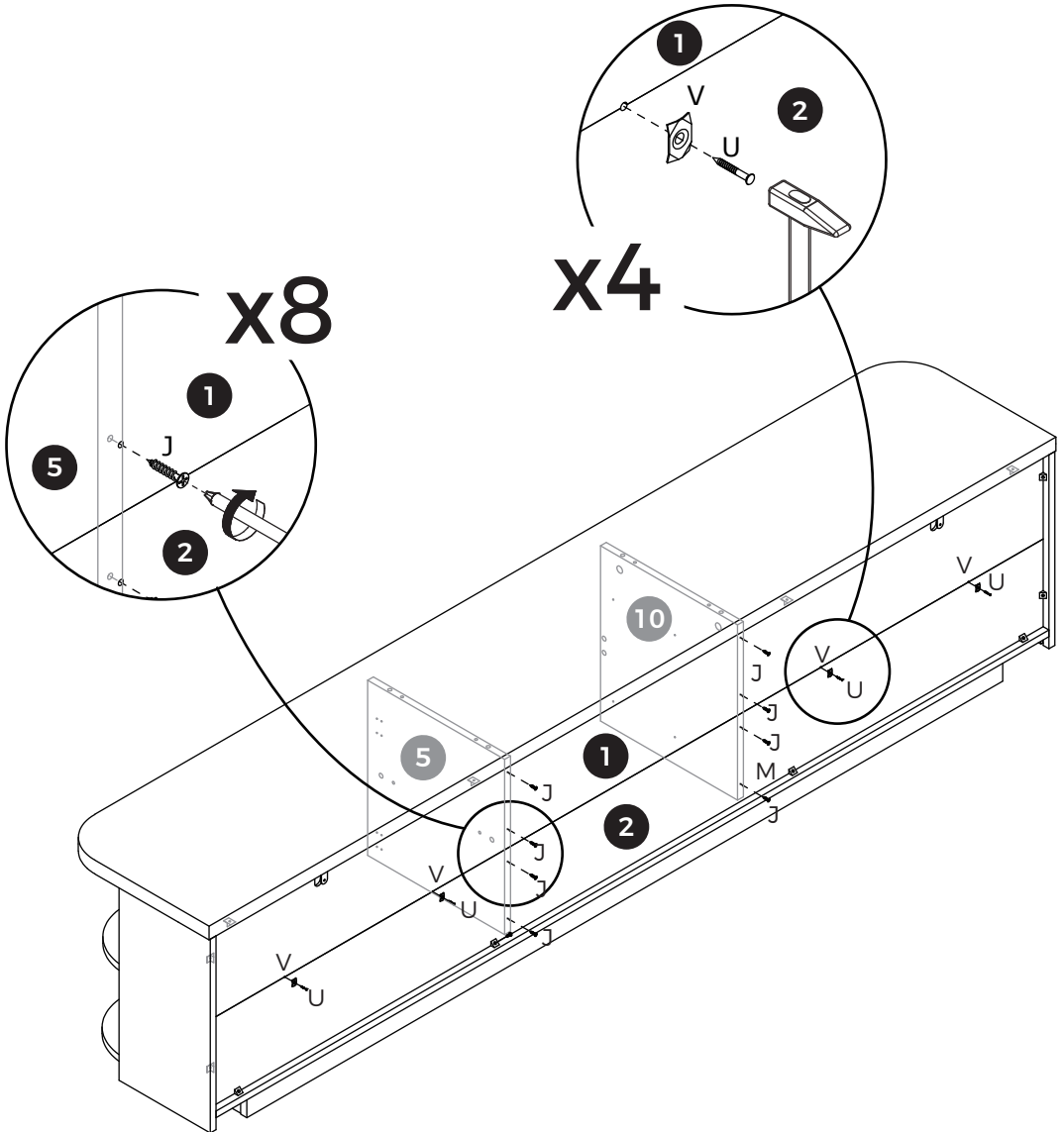

27



[EN] Install the anti-tip device.

[ES] Instale el dispositivo antivuelco.

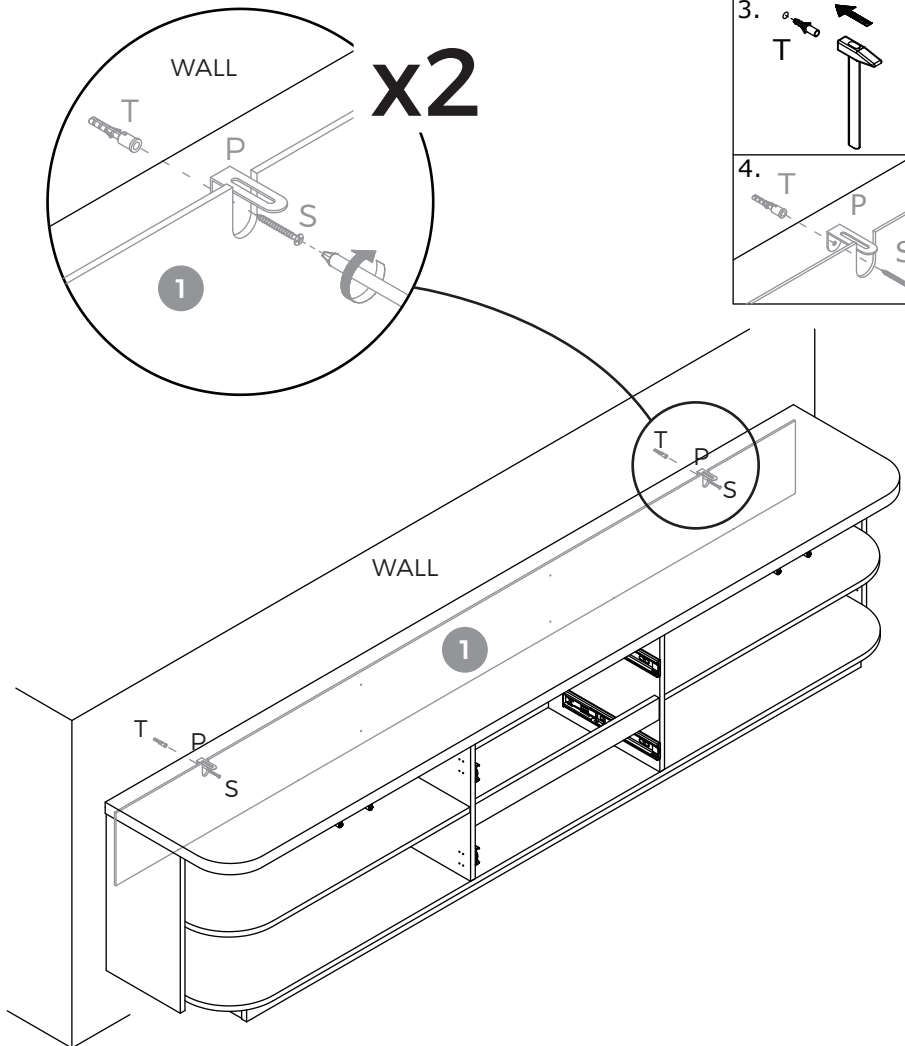
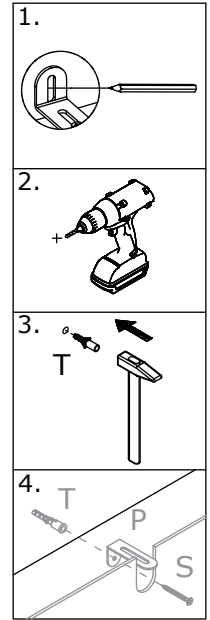

28

[EN] Note the difference in the middle section of the two hinge types.

- Door hinges (K) go on the outermost left and right door panels.
- Door hinges (F) go on the middle door panels.

[ES] Observe la diferencia en la parte central de los dos tipos de bisagras.

- Las bisagras (K) van en los paneles de puerta exteriores izquierdo y derecho.
- Las bisagras (F) van en los paneles de puerta centrales.

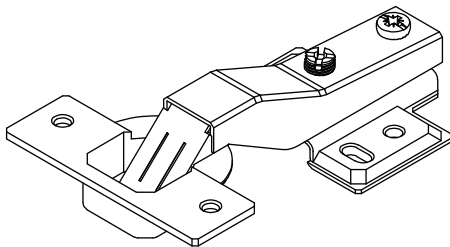

F

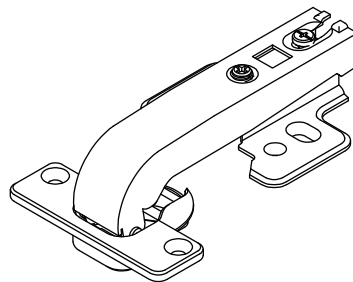

K

29

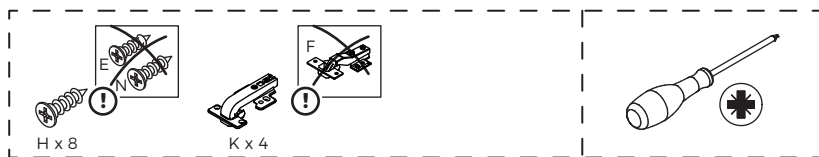

[EN] Attach hinge (K) to panel 12 with screws (H).

[ES] Fije la bisagra (K) al panel 12 con los tornillos (H).

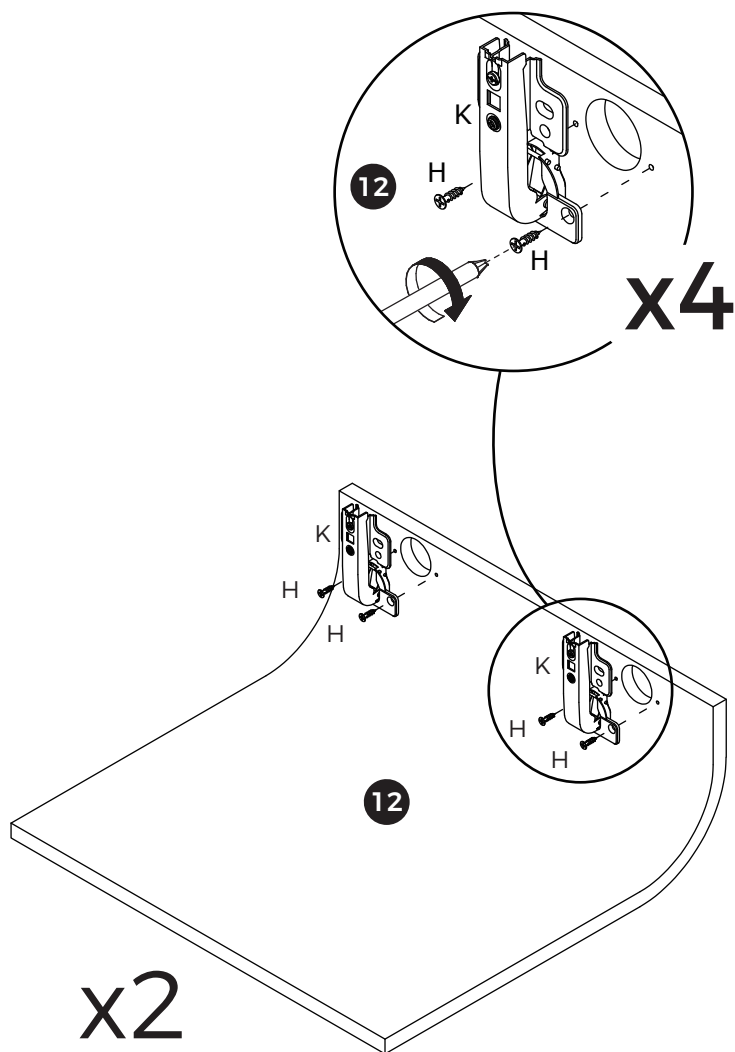

30



[EN] Attach hinge (K) to panels 3 and 8 with screws (H).

[ES] Fije la bisagra (K) a los paneles 3 y 8 con los tornillos (H).

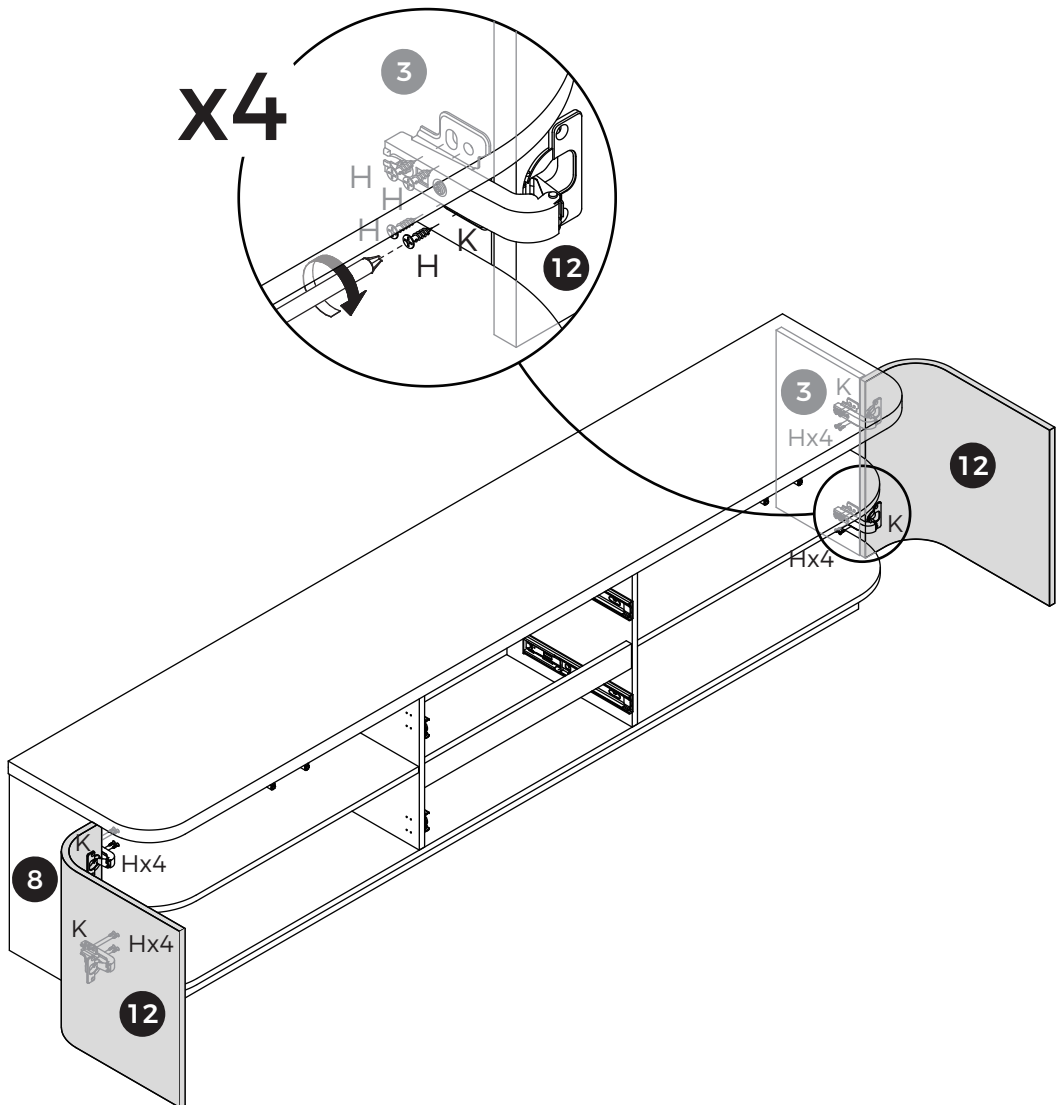

31

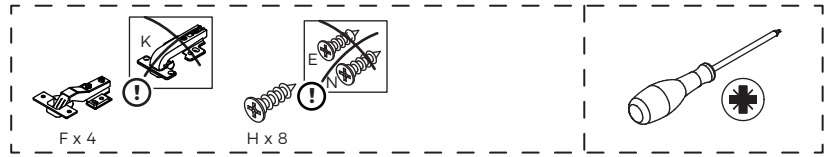

[EN] Attach hinge (F) to panel 20 with screws (H).

[ES] Fije la bisagra (F) al panel 20 con los tornillos (H).

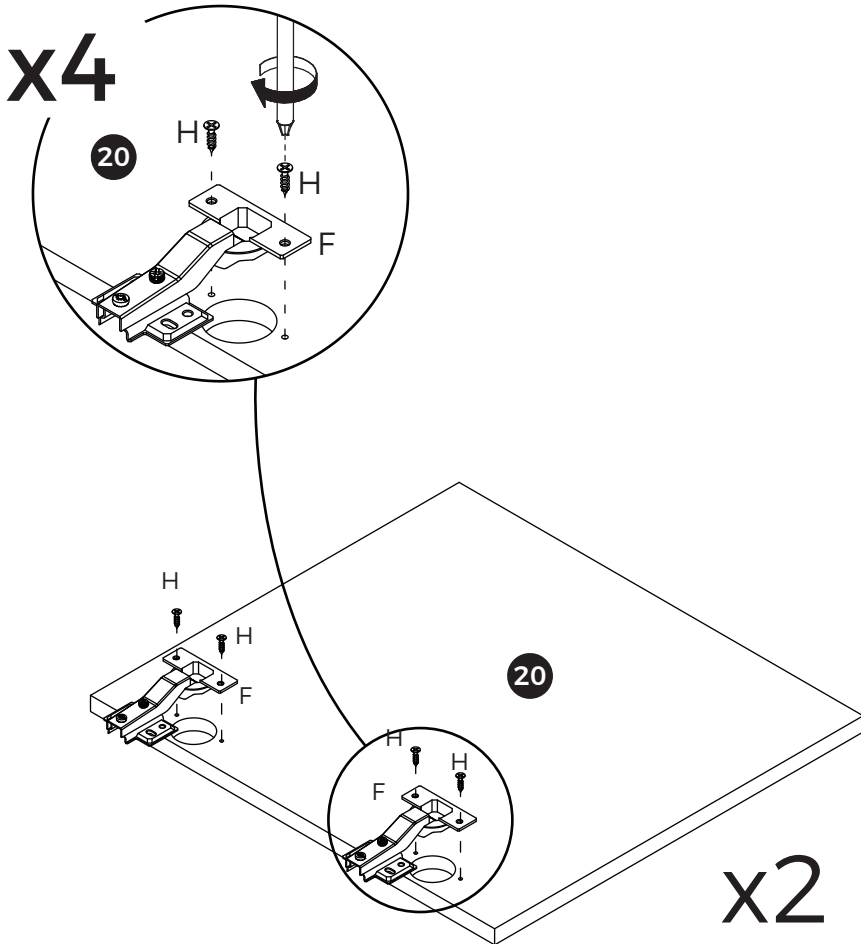

32



[EN] Attach hinge (F) to panels 5 and 10 with screws (H).

[ES] Fije la bisagra (F) a los paneles 5 y 10 con los tornillos (H).

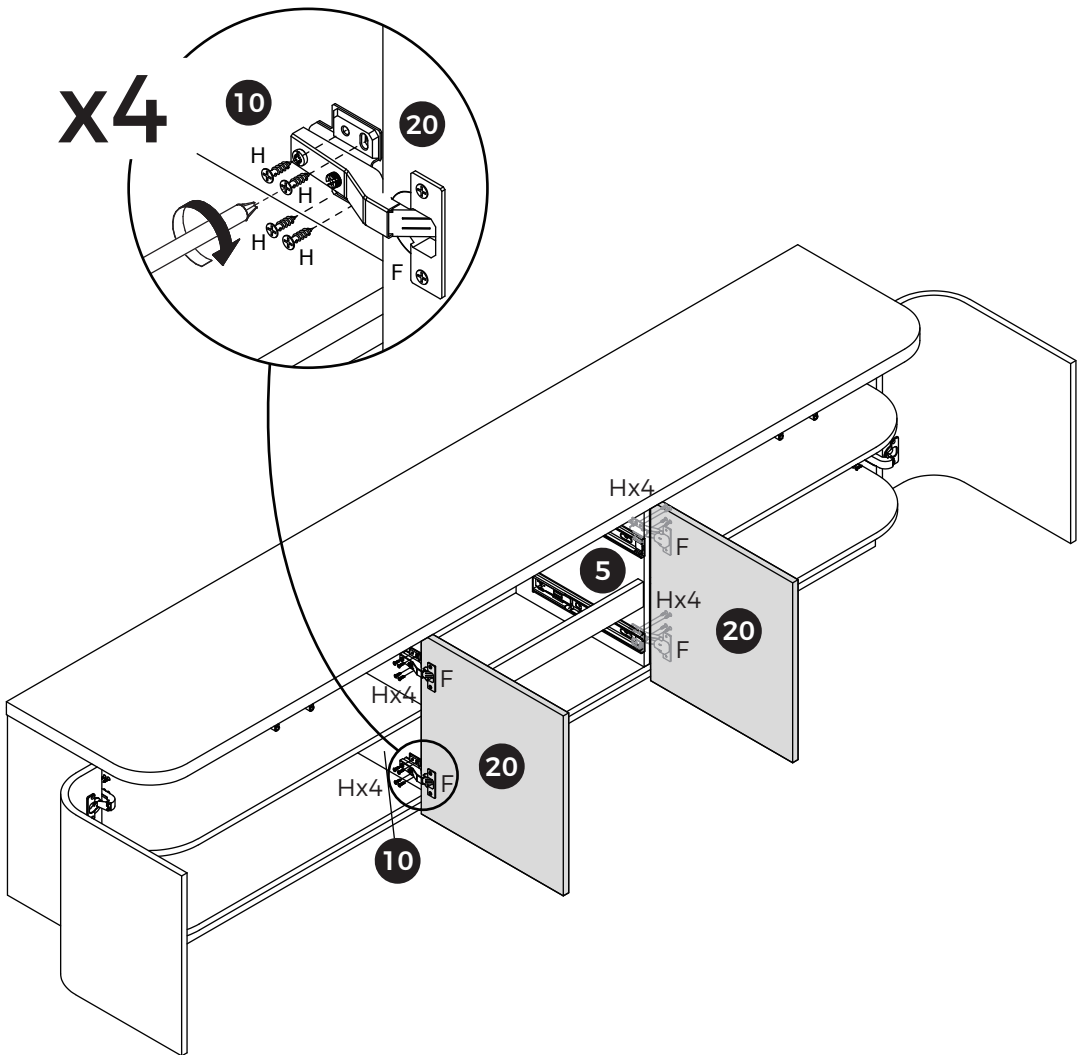

33



[EN] Insert plug (D) into panel 17, then screw self-tapping rod (B) into panel 17.

[ES] Inserte el tapón (D) en el panel 17 y luego atornille la varilla autoperforante (B) en el panel 17.

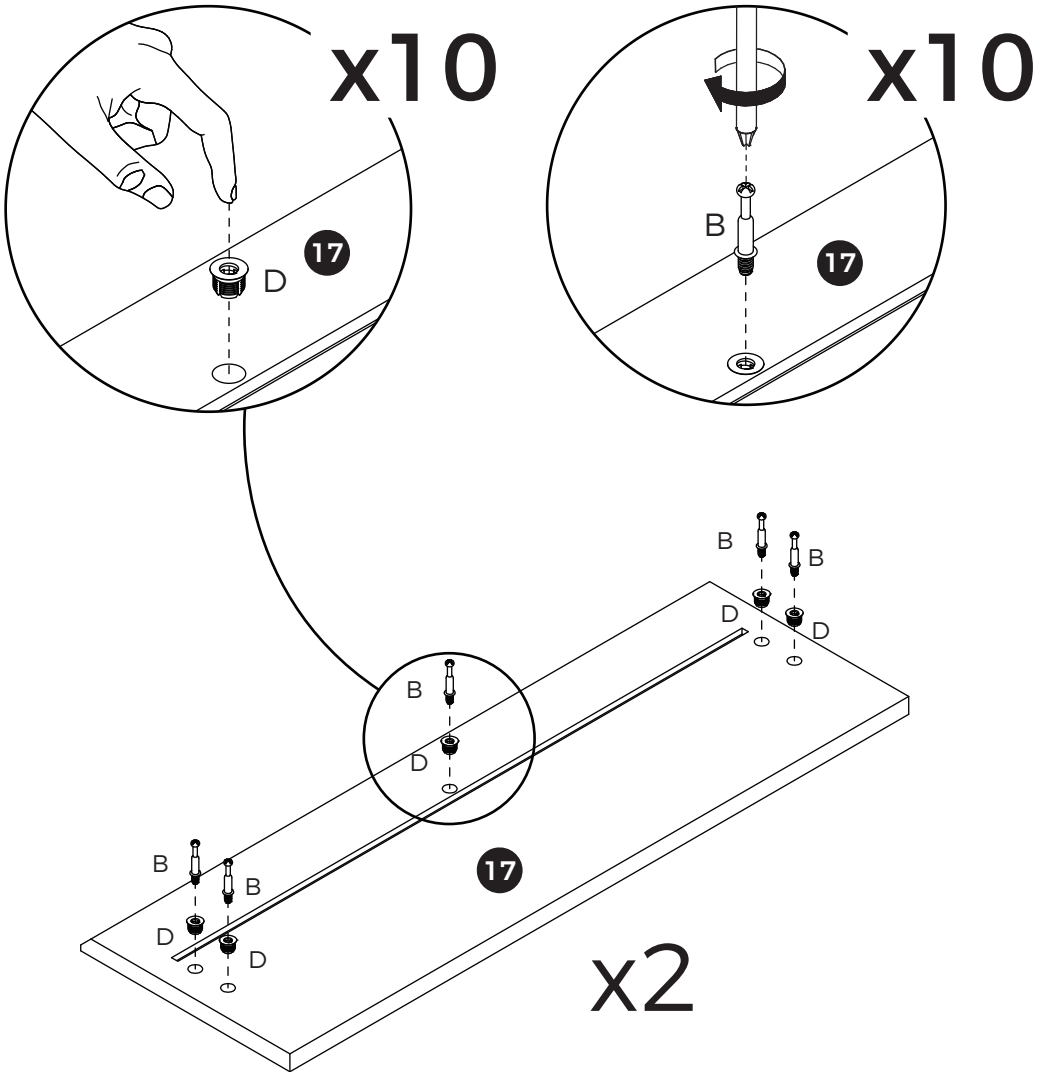

34



[EN] Connect panels 4, 9, and 15 to panel 17, and tighten the eccentric wheel (A) clockwise as shown.

[ES] Conecte los paneles 4, 9 y 15 al panel 17 y apriete la rueda excéntrica (A) en sentido horario, como se muestra.

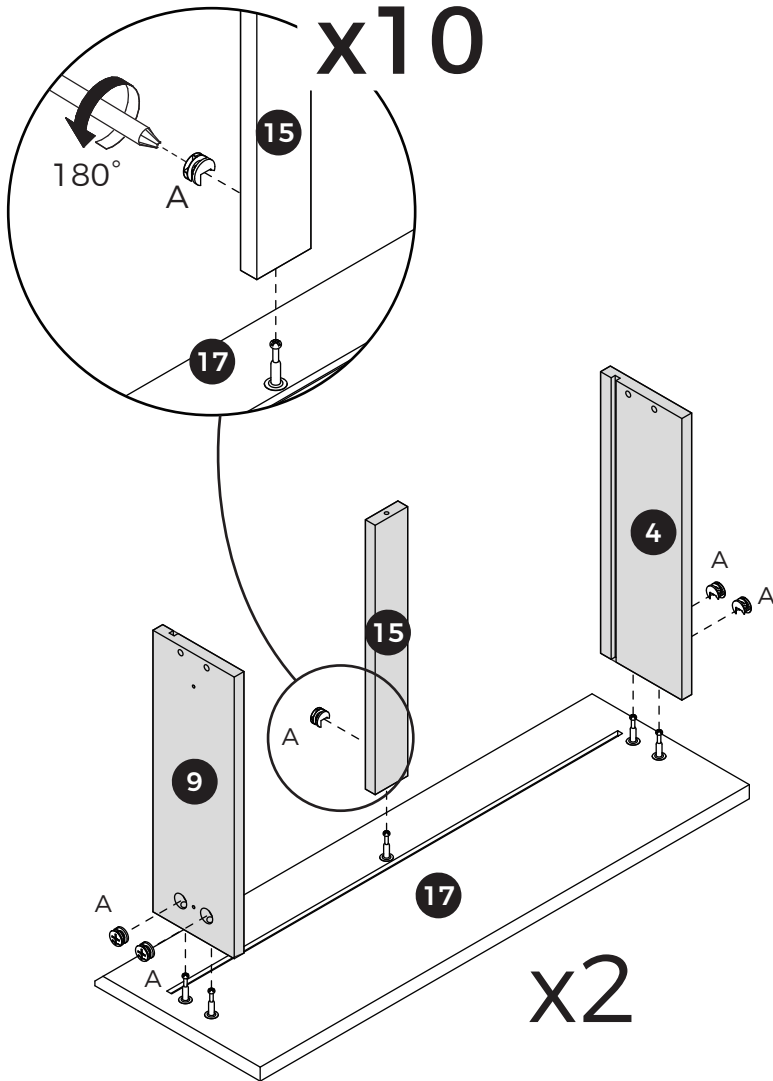

35

[EN] Insert panel 14 along the available slots.

[ES] Inserte el panel 14 a lo largo de las ranuras disponibles.

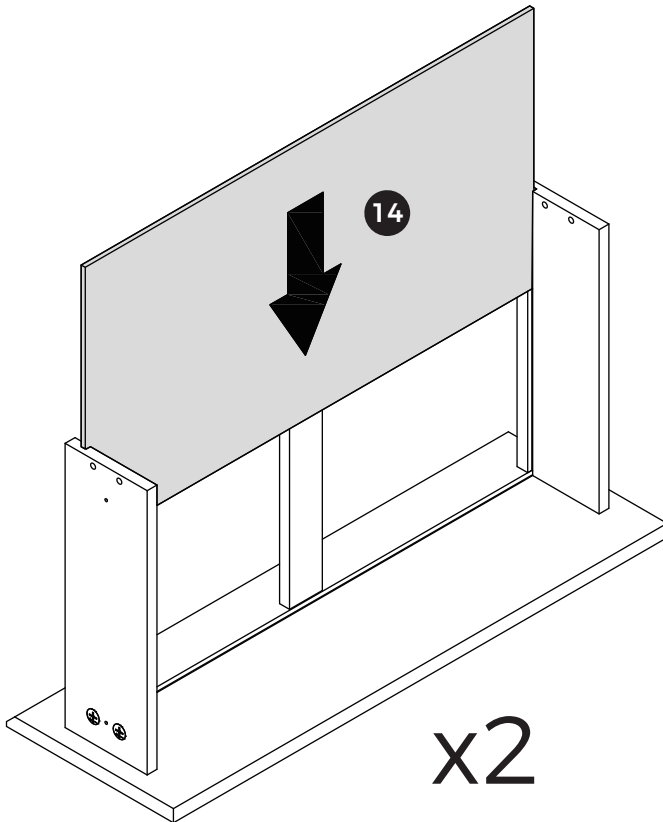

36



[EN] Connect panels 4, 9, and 15 to panel 13 with screw (G).

[ES] Conecte los paneles 4, 9 y 15 al panel 13 con el tornillo (G).

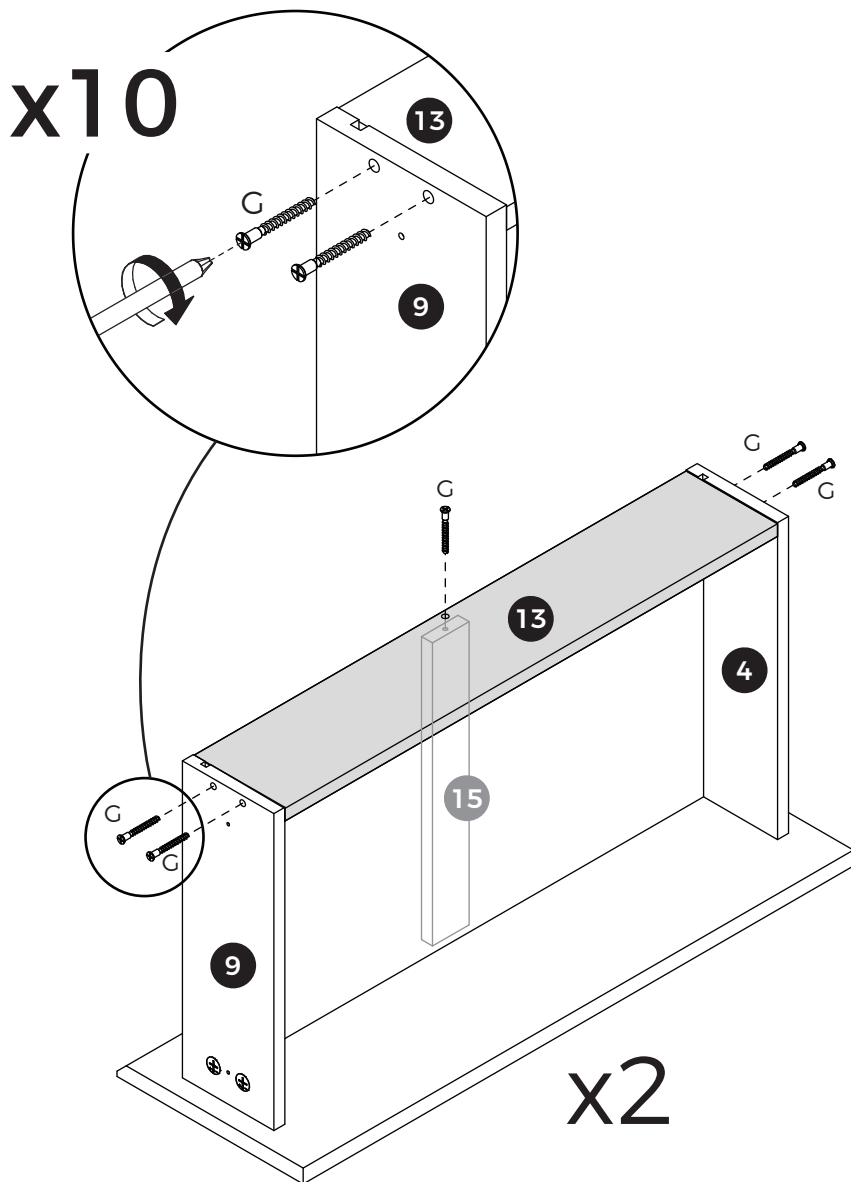

37



[EN] Secure slide rail R (R-2) to panels 4 and 9 with screws (E).

[ES] Fije el riel deslizante R (R-2) a los paneles 4 y 9 con los tornillos (E).

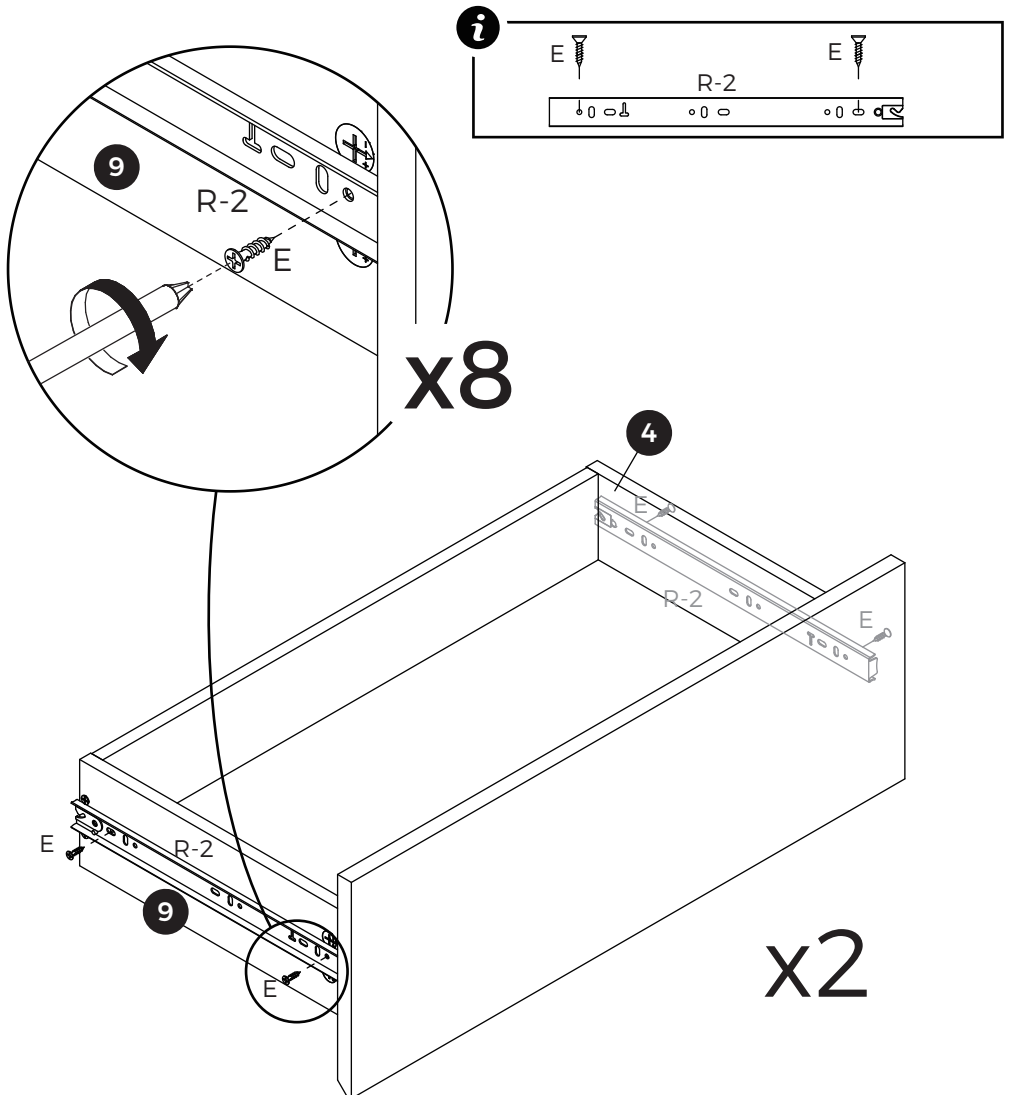

38

[EN] Align the drawer slides and push drawers into the cabinet.

[ES] Alinee las guías de los cajones y empuje los cajones dentro del gabinete.

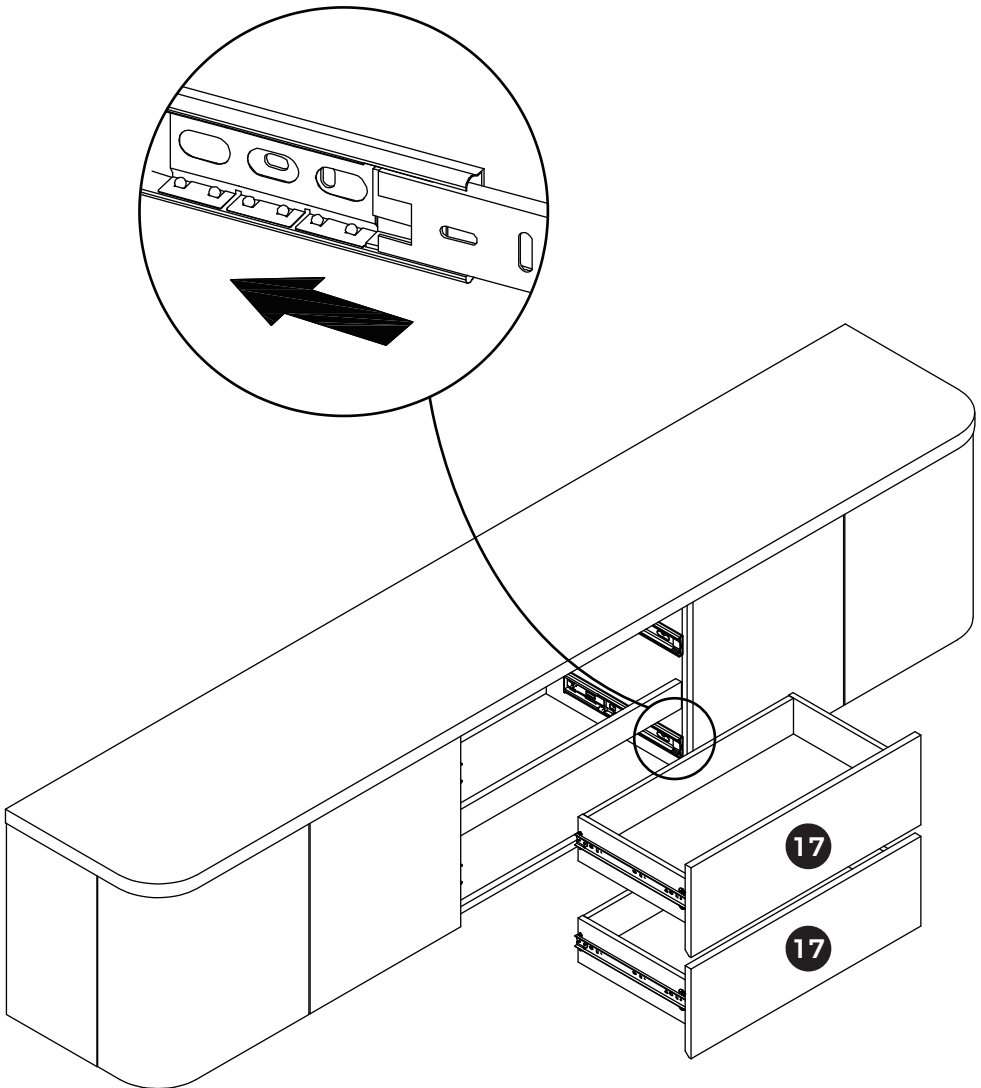

39

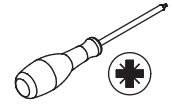

(EN) If the doors are still misaligned after adjusting the hinges, please watch the video.

(ES) Si las puertas siguen desalineadas después de ajustar las bisagras, por favor mira el video.

(EN) If there is misalignment after installation, adjust the hinge screw as needed.

(ES) Si hay desalineación después de la instalación, ajusta el tornillo de la bisagra según sea necesario.

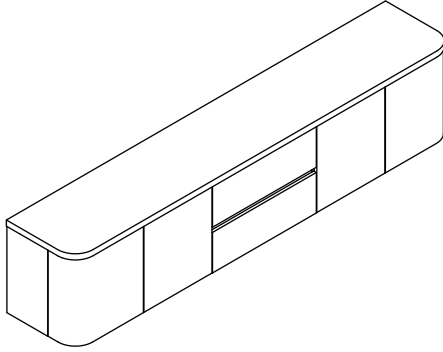

<https://youtu.be/n0Lb36SoODM>

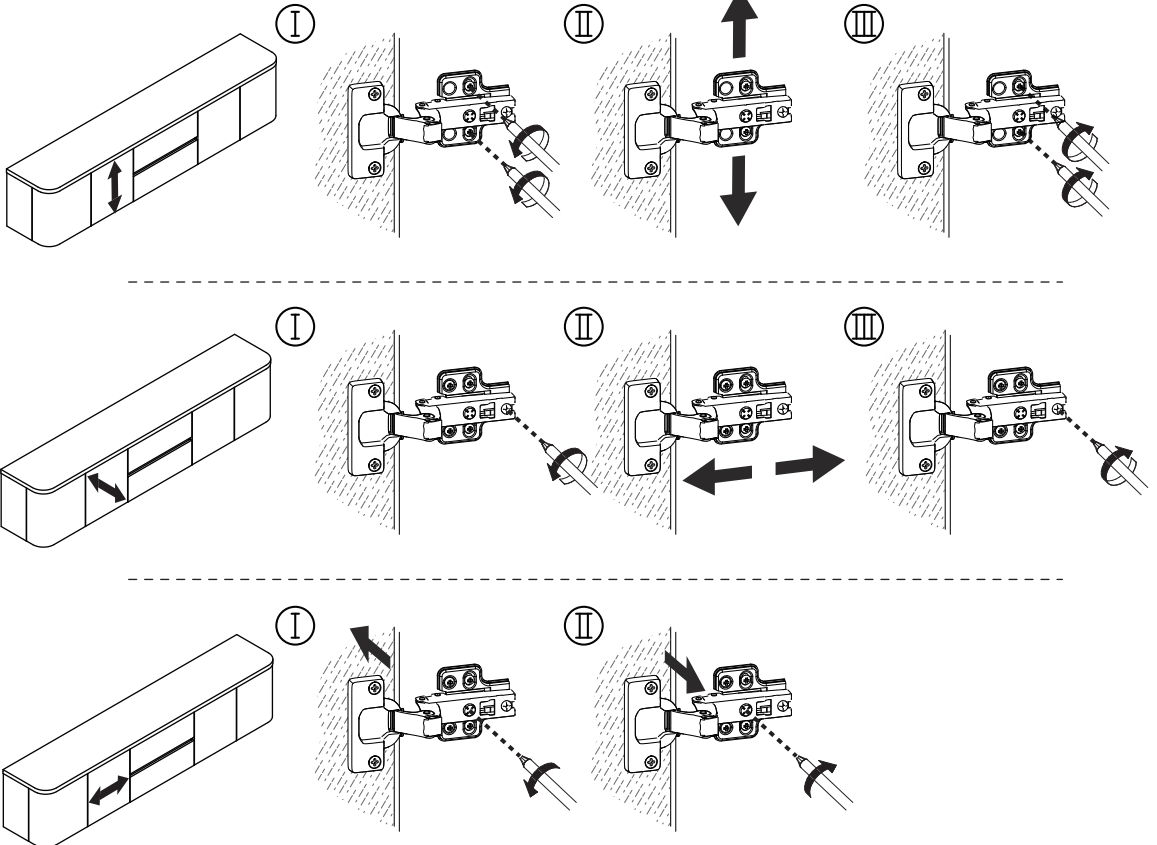

Should you have any problems assembling your product, contact us at **customerservice@homsee.com**. We're always happy to help! We have carefully selected the materials used in this product, and ask you to treat it responsibly too. Please recycle all packaging according to your local disposal rules.

Si tienes algún problema al ensamblar tu producto, contáctanos a **customerservice@homsee.com**. Siempre estaremos encantados de ayudarte. Hemos seleccionado cuidadosamente los materiales utilizados en este producto y te pedimos que también lo trates de manera responsable. Por favor, recicla todo el embalaje de acuerdo con las normas locales de eliminación de residuos.

