

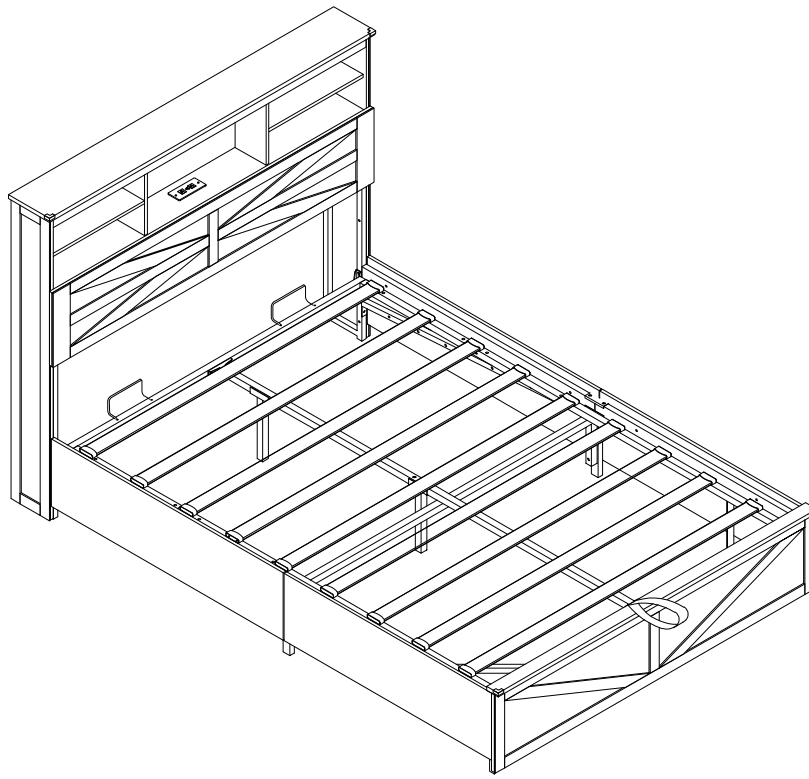

Version:1.0
AJ-DJ505418

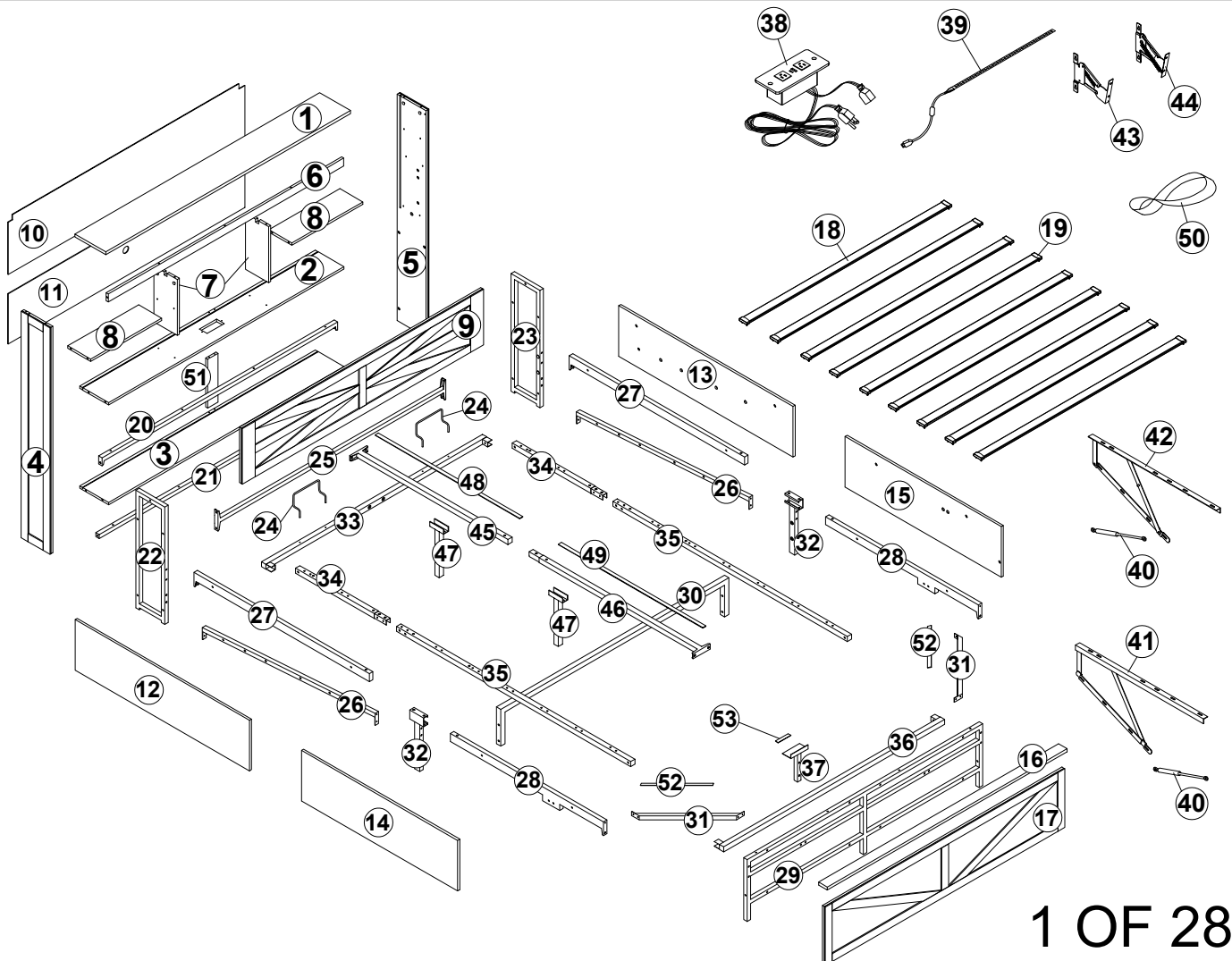



Note:
Should be assembled on flat ground to keep balance.
It needs at least two people to install.
Before starting the assembly, you must read the whole manual and follow the instructions.

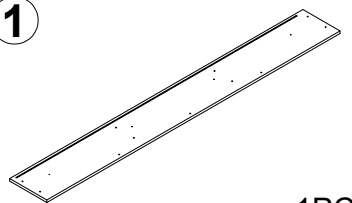
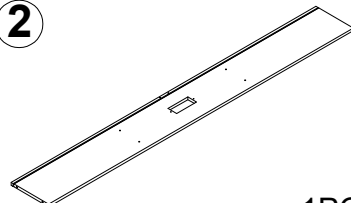
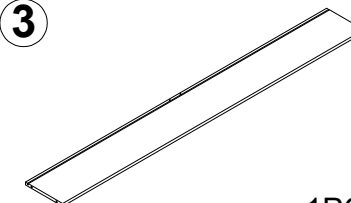
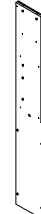

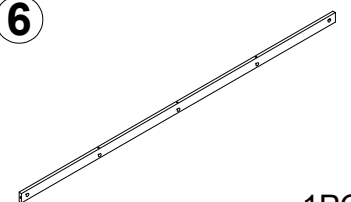
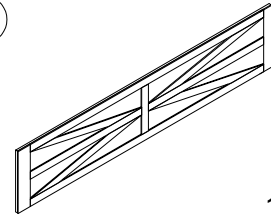
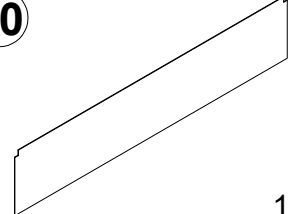
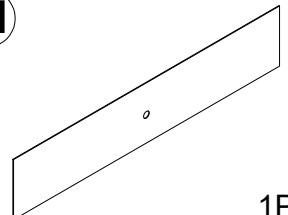
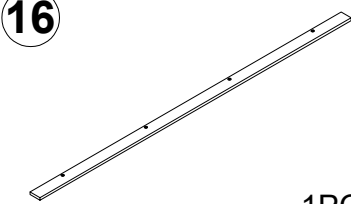
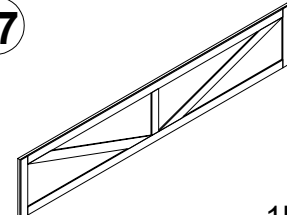
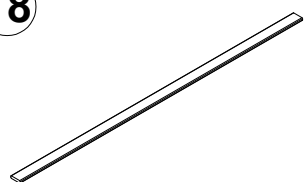
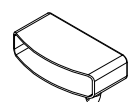
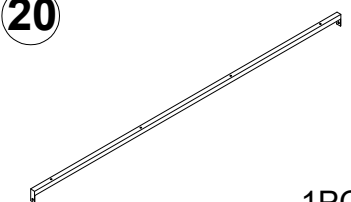
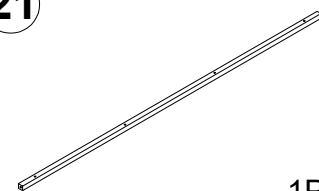
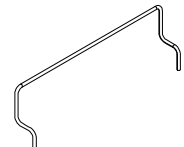
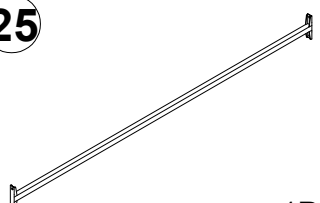
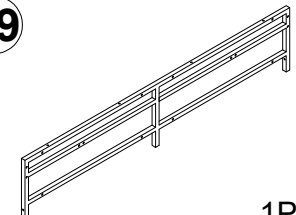
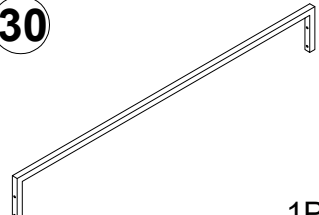
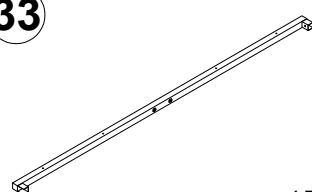
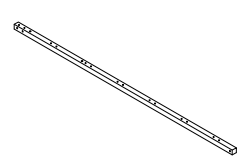
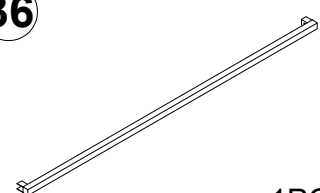
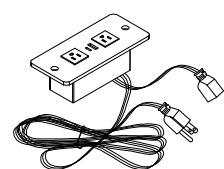
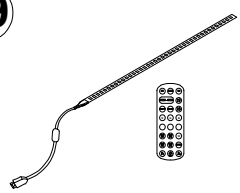
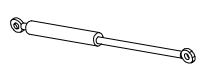
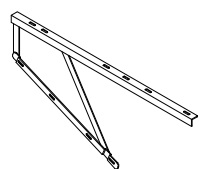
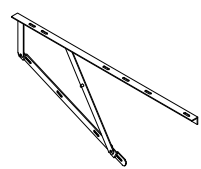
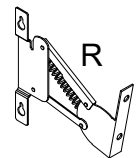
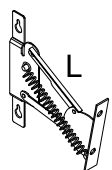
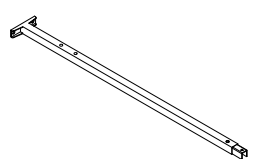
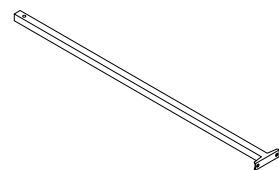
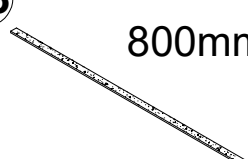

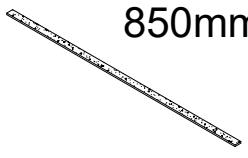
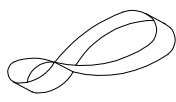
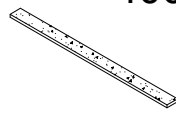
Part list for A box





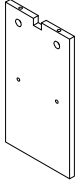
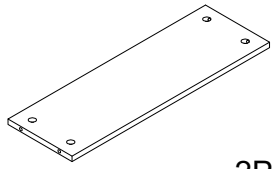
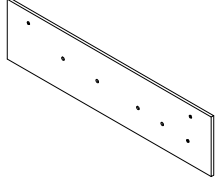
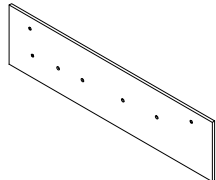
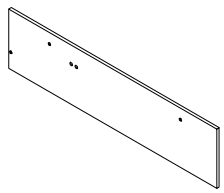
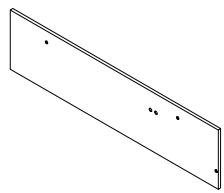
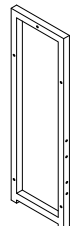
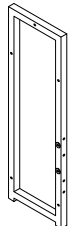
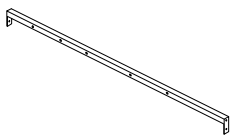
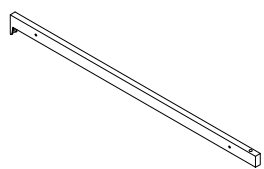
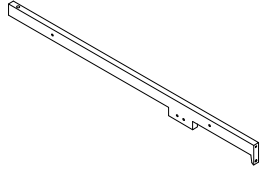
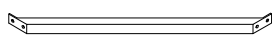
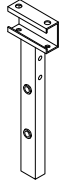
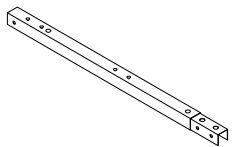
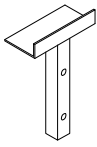
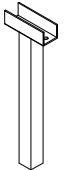









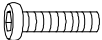

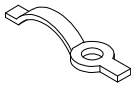
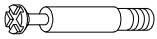

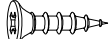
<p>1</p>  <p>1PC</p>	<p>2</p>  <p>1PC</p>	<p>3</p>  <p>1PC</p>	<p>4</p>  <p>1PC</p>
<p>5</p>  <p>1PC</p>	<p>6</p>  <p>1PC</p>	<p>9</p>  <p>1PC</p>	<p>10</p>  <p>1PC</p>
<p>11</p>  <p>1PC</p>	<p>16</p>  <p>1PC</p>	<p>17</p>  <p>1PC</p>	<p>18</p>  <p>9PCS</p>
<p>19</p>  <p>18PCS</p>	<p>20</p>  <p>1PC</p>	<p>21</p>  <p>1PC</p>	<p>24</p>  <p>2PCS</p>
<p>25</p>  <p>1PC</p>	<p>29</p>  <p>1PC</p>	<p>30</p>  <p>1PC</p>	<p>33</p>  <p>1PC</p>
<p>35</p>  <p>2PCS</p>	<p>36</p>  <p>1PC</p>	<p>38</p>  <p>1PC</p>	<p>39</p>  <p>1PC</p>
<p>40</p>  <p>2PCS</p>	<p>41</p>  <p>1PC</p>	<p>42</p>  <p>1PC</p>	<p>43</p>  <p>1PC</p>
<p>44</p>  <p>1PC</p>	<p>45</p>  <p>1PC</p>	<p>46</p>  <p>1PC</p>	<p>48</p>  <p>800mm 1PC</p>

49  850mm 1PC	50  1PC	52  400mm 2PCS	53  90mm 1PC
--	---	--	---

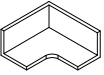

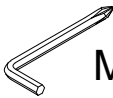
Part list for B box

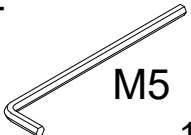
7  2PCS	8  2PCS	12  1PC	13  1PC
14  1PC	15  1PC	22  1PC	23  1PC
26  2PCS	27  2PCS	28  2PCS	31  2PCS
32  2PCS	34  2PCS	37  1PC	47  2PCS
51  1PC			

Hardware list for A box



<p>A M8x45</p>  <p>16+4PCS</p>	<p>B</p>  <p>16+4PCS</p>	<p>C M8x55</p>  <p>4+1PCS</p>	<p>D M6x15</p>  <p>12+1PCS</p>	<p>E M6x20</p>  <p>12+1PCS</p>
<p>F M8x35</p>  <p>10+1PCS</p>	<p>G M6x28</p>  <p>44+4PCS</p>	<p>H M5x40</p>  <p>8+1PCS</p>	<p>I</p>  <p>4+1PC</p>	<p>J</p>  <p>29+2PCS</p>
<p>K</p>  <p>29+2PCS</p>	<p>L M3.5x12</p>  <p>18+1PCS</p>	<p>M</p>  <p>12+1PCS</p>	<p>N</p>  <p>8+2PCS</p>	<p>O</p>  <p>1PC</p>
<p>P</p>  <p>4PCS</p>	<p>Q M6x10</p>  <p>18+1PCS</p>	<p>R</p>  <p>M4 1PC</p>	<p>S</p>  <p>M4 2PCS</p>	<p>T</p>  <p>M5 1PC</p>
<p>U M6x40</p>  <p>10+1PCS</p>	<p>V M8x16</p>  <p>8+1PCS</p>			

Step 1

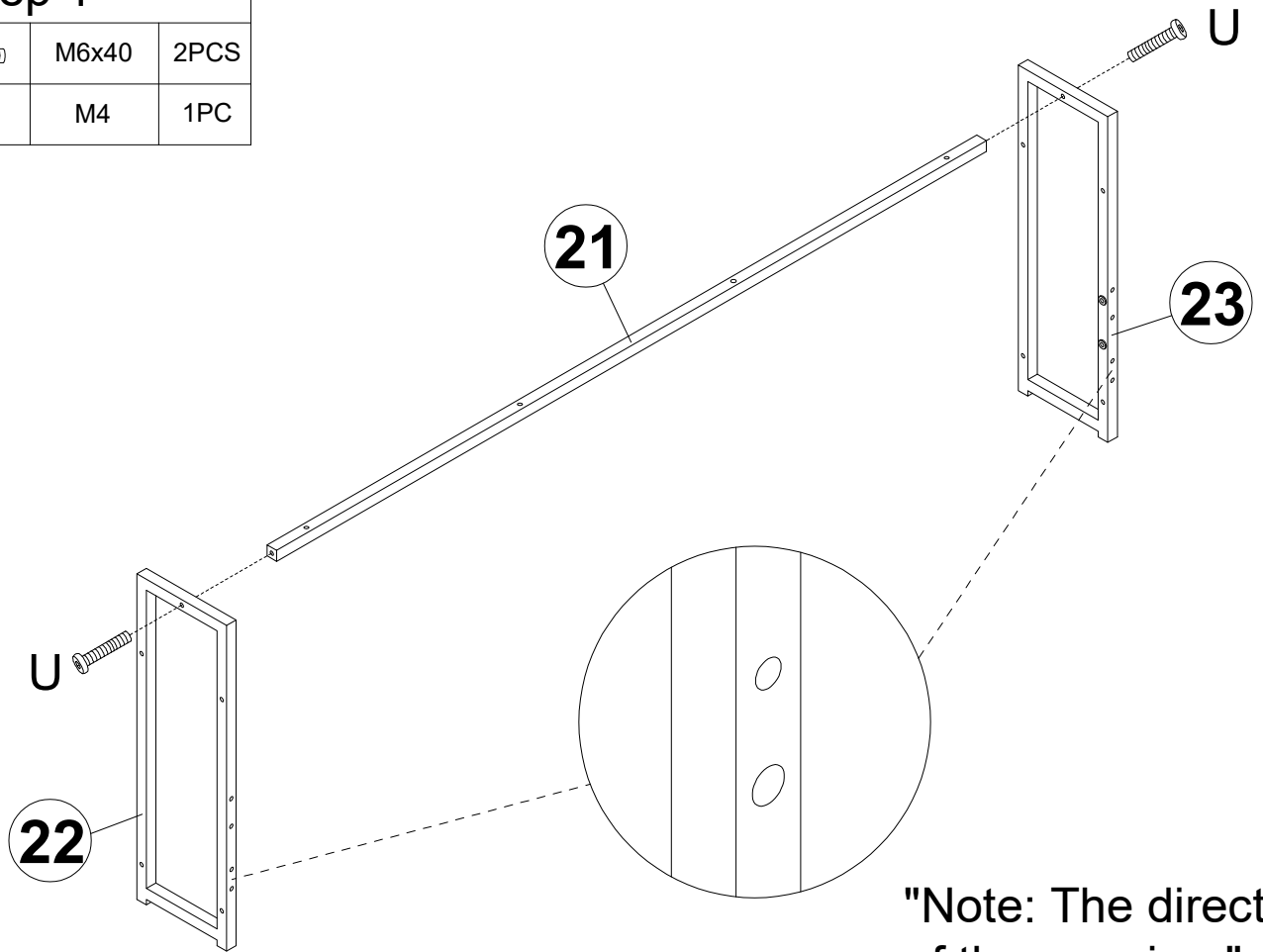
U		M6x40	2PCS
S		M4	1PC



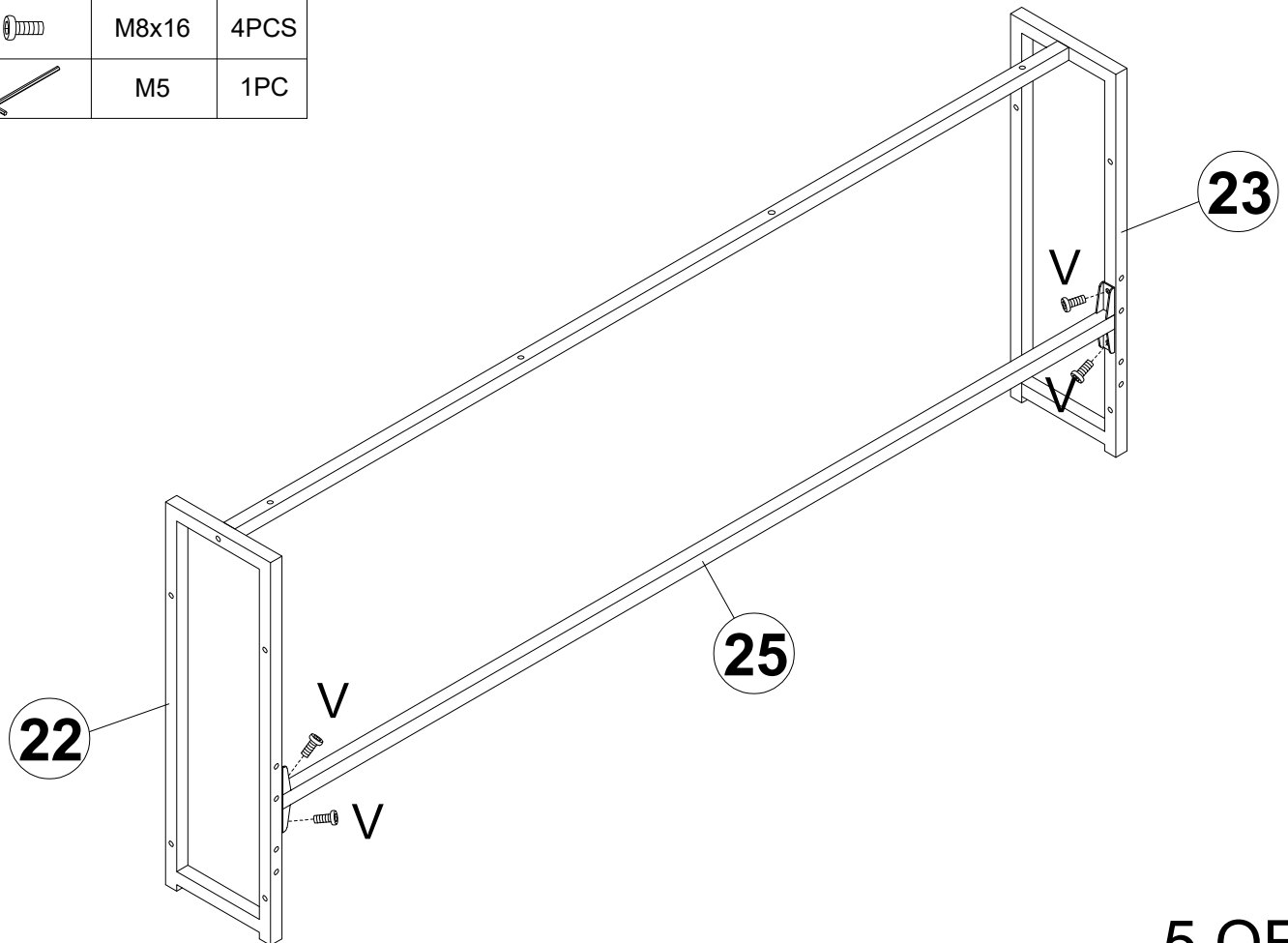

Step 2

V		M8x16	4PCS
T		M5	1PC





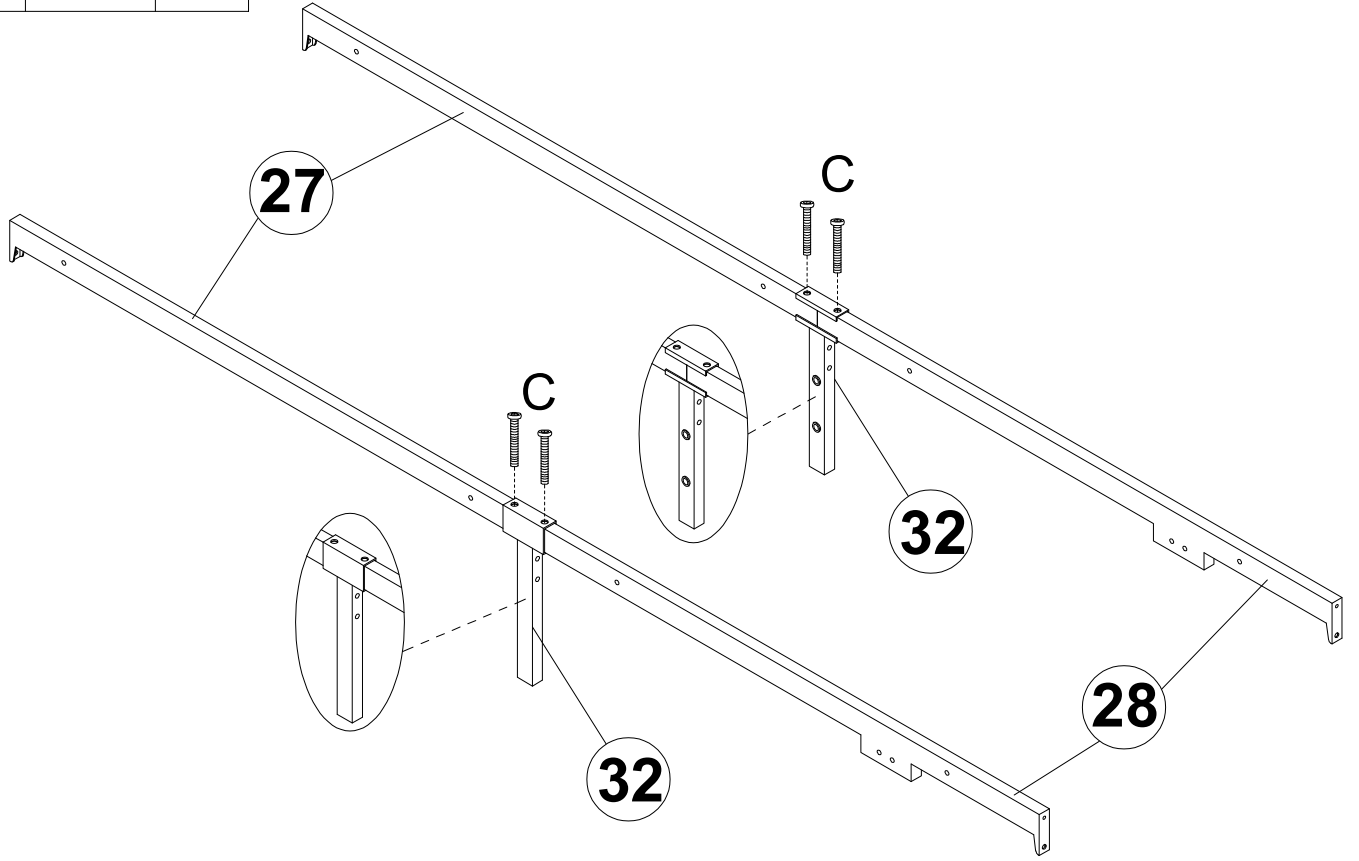

Step 3

C		M8x55	4PCS
T		M5	1PC





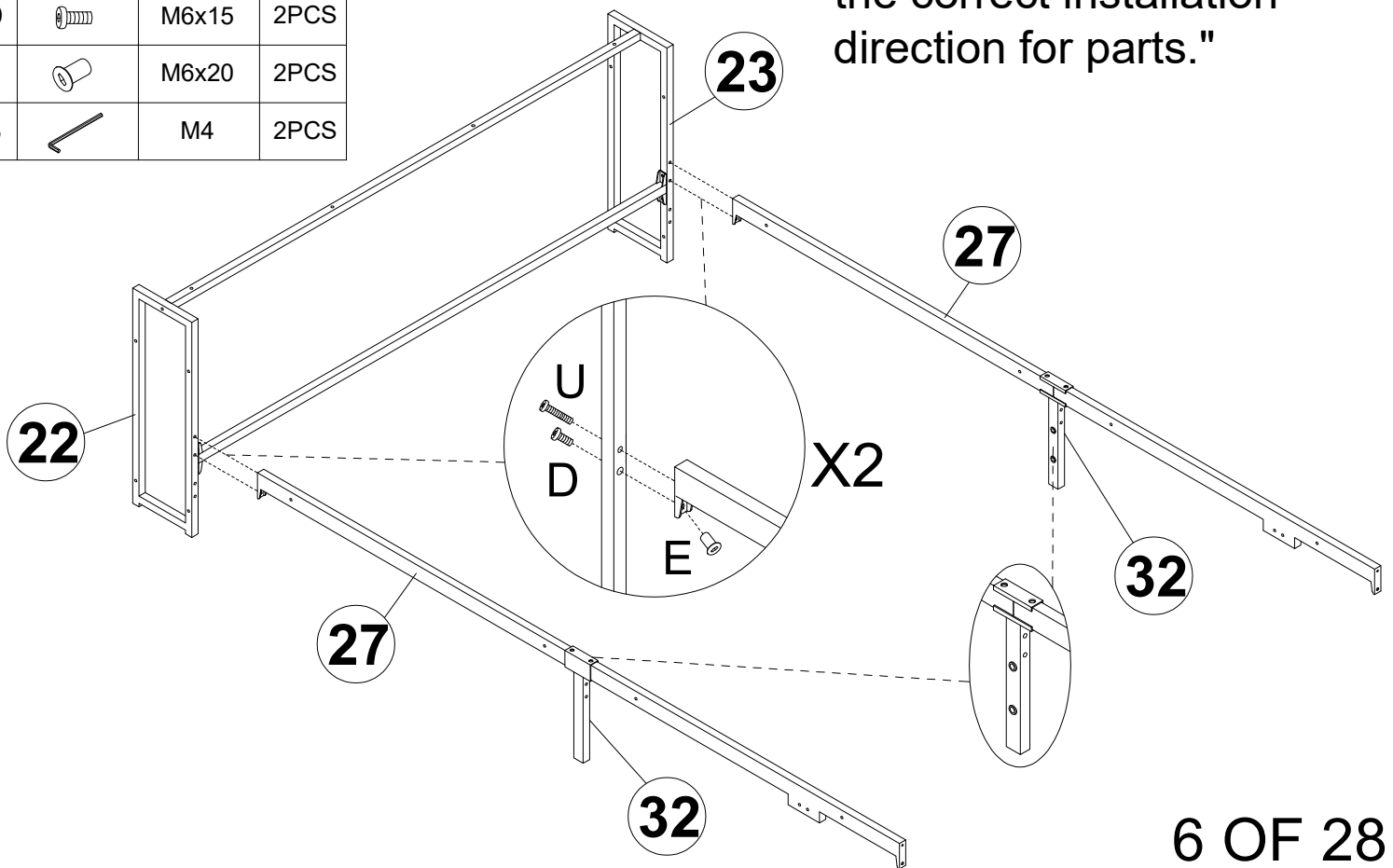

Step 4

U		M6x40	2PCS
D		M6x15	2PCS
E		M6x20	2PCS
S		M4	2PCS

"Note: Make sure to follow the correct installation direction for parts."





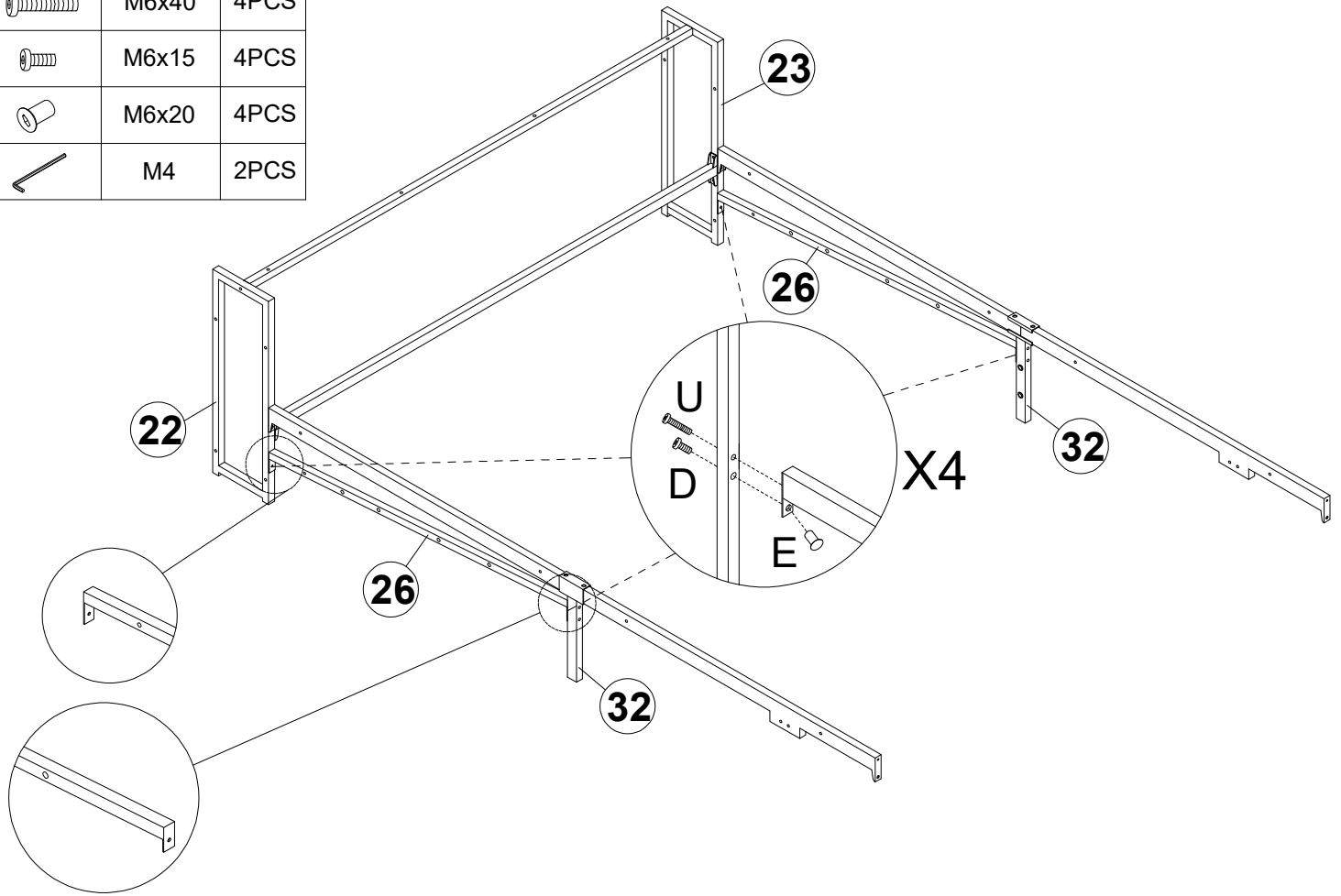

Step 5

U		M6x40	4PCS
D		M6x15	4PCS
E		M6x20	4PCS
S		M4	2PCS





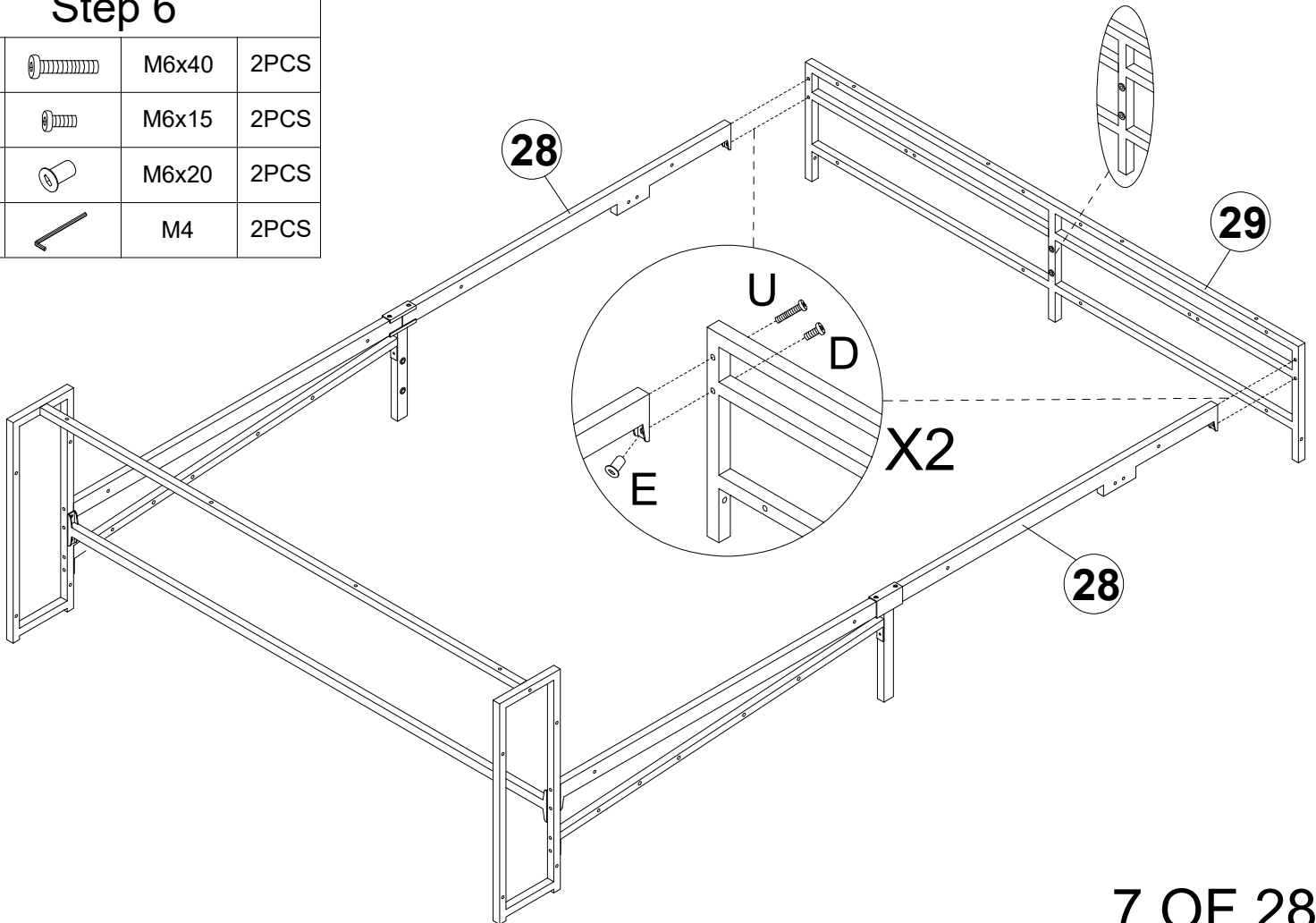

Step 6

U		M6x40	2PCS
D		M6x15	2PCS
E		M6x20	2PCS
S		M4	2PCS



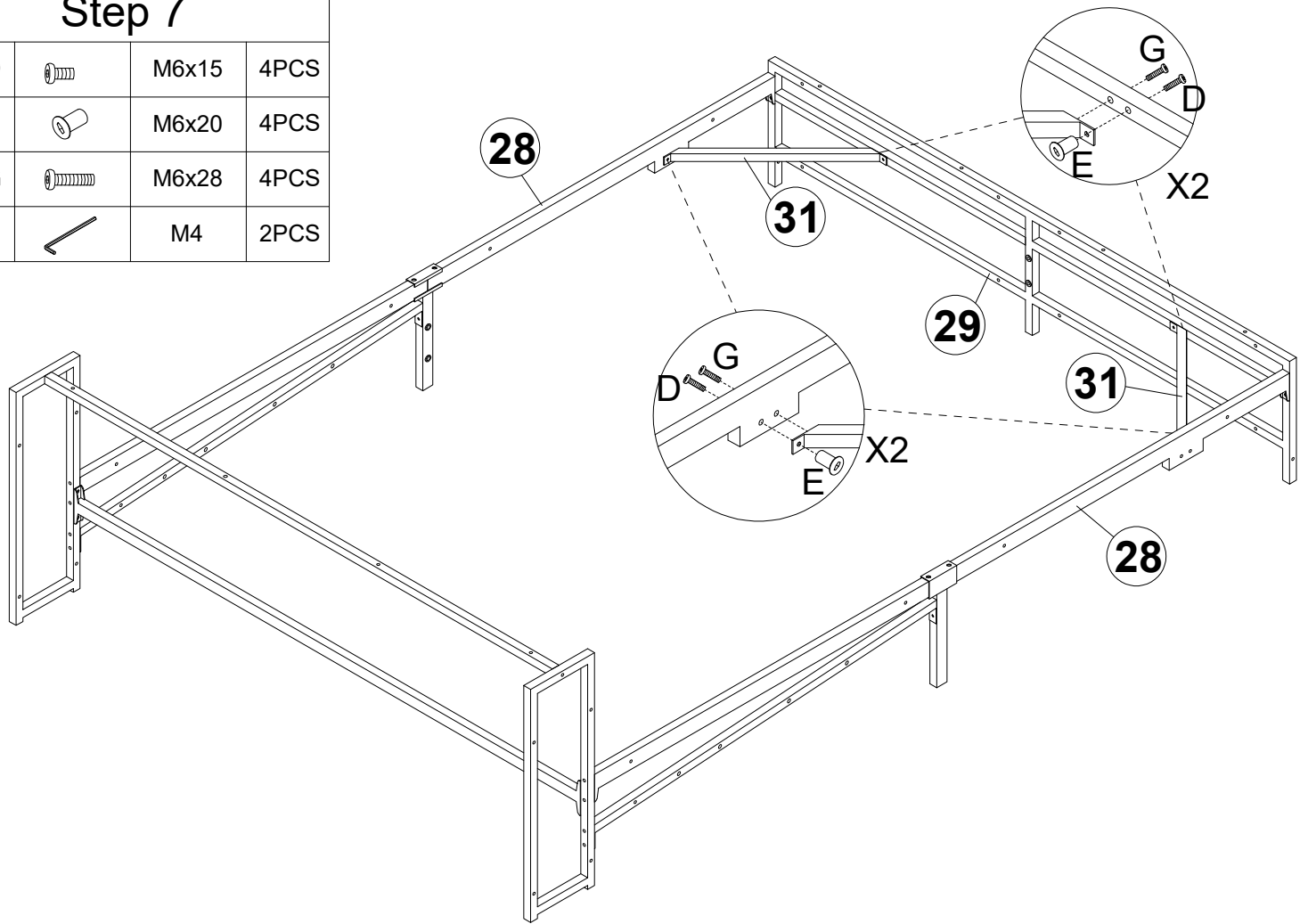

Step 7

D		M6x15	4PCS
E		M6x20	4PCS
G		M6x28	4PCS
S		M4	2PCS



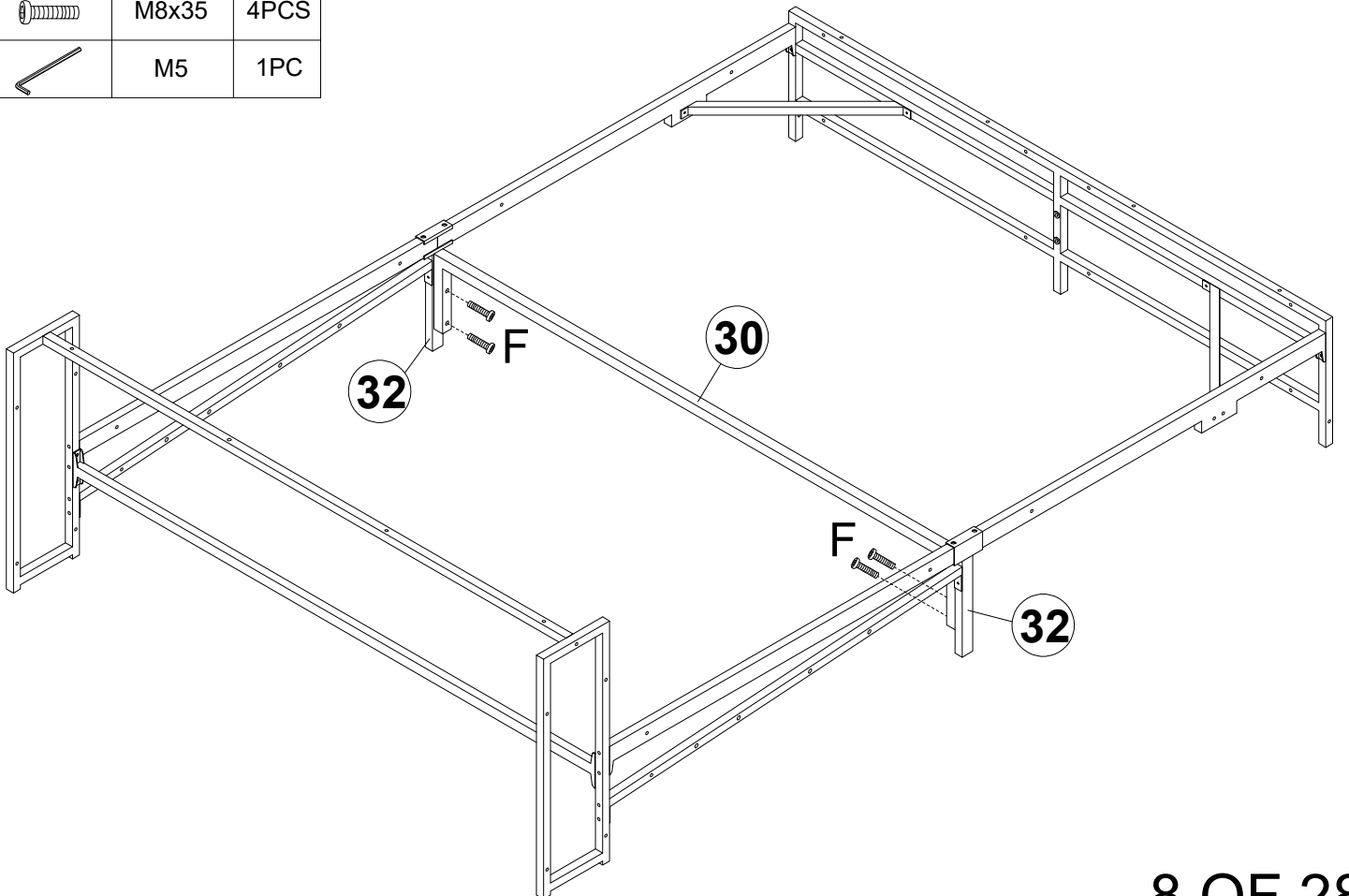

Step 8

F		M8x35	4PCS
T		M5	1PC



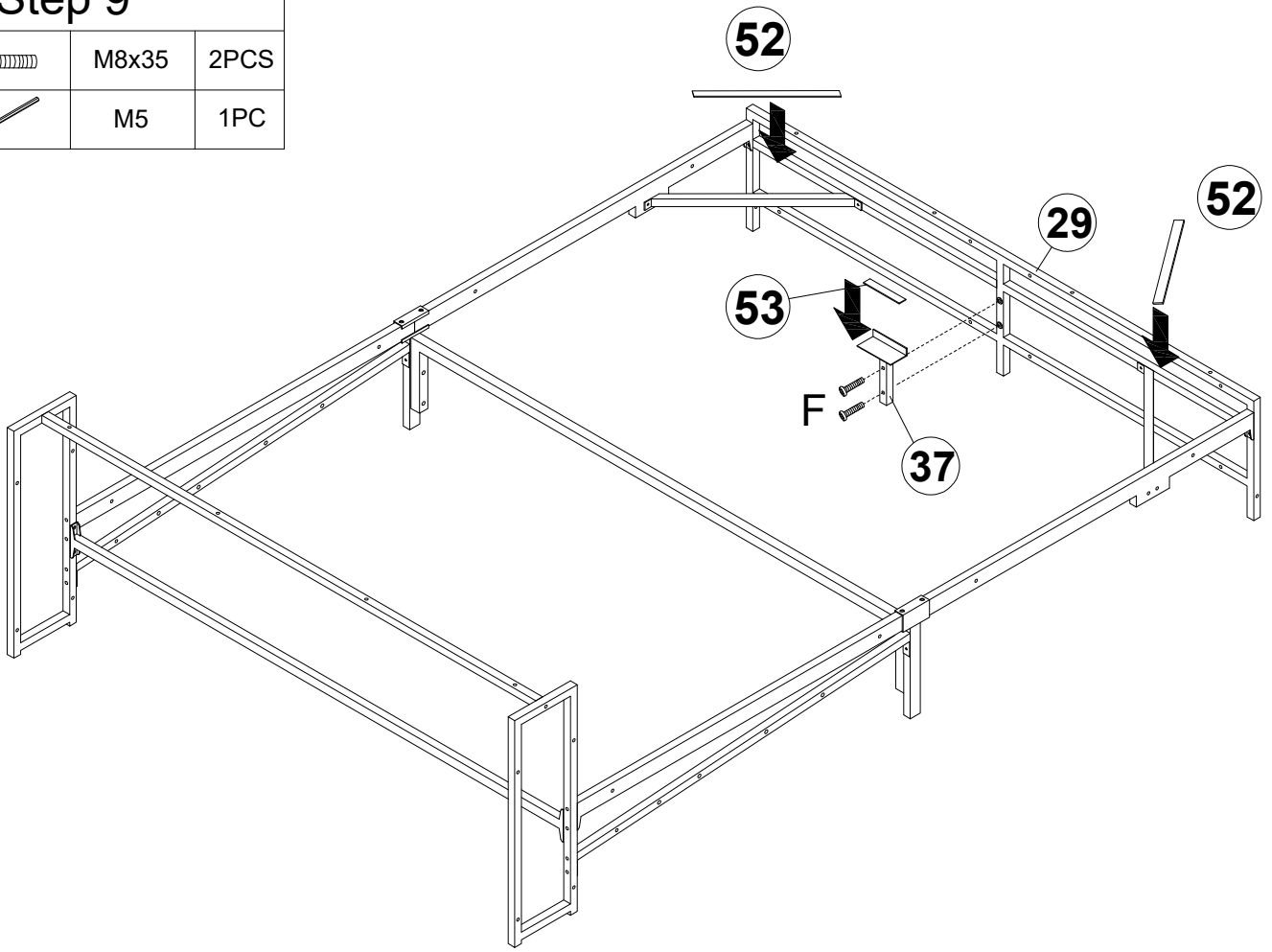

Step 9

F		M8x35	2PCS
T		M5	1PC



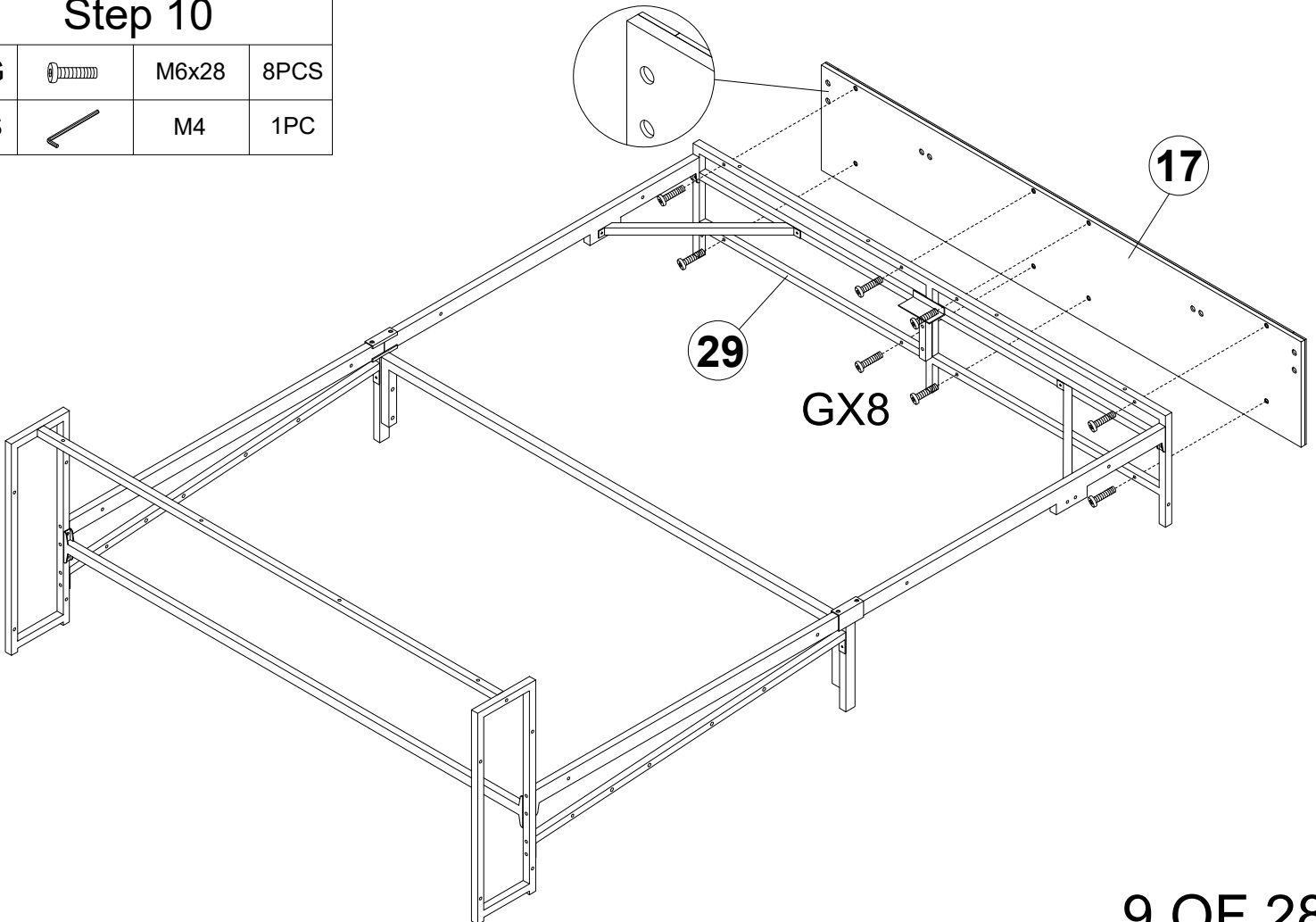

Step 10

G		M6x28	8PCS
S		M4	1PC





Step 11

G		M6x28	4PCS
S		M4	1PC

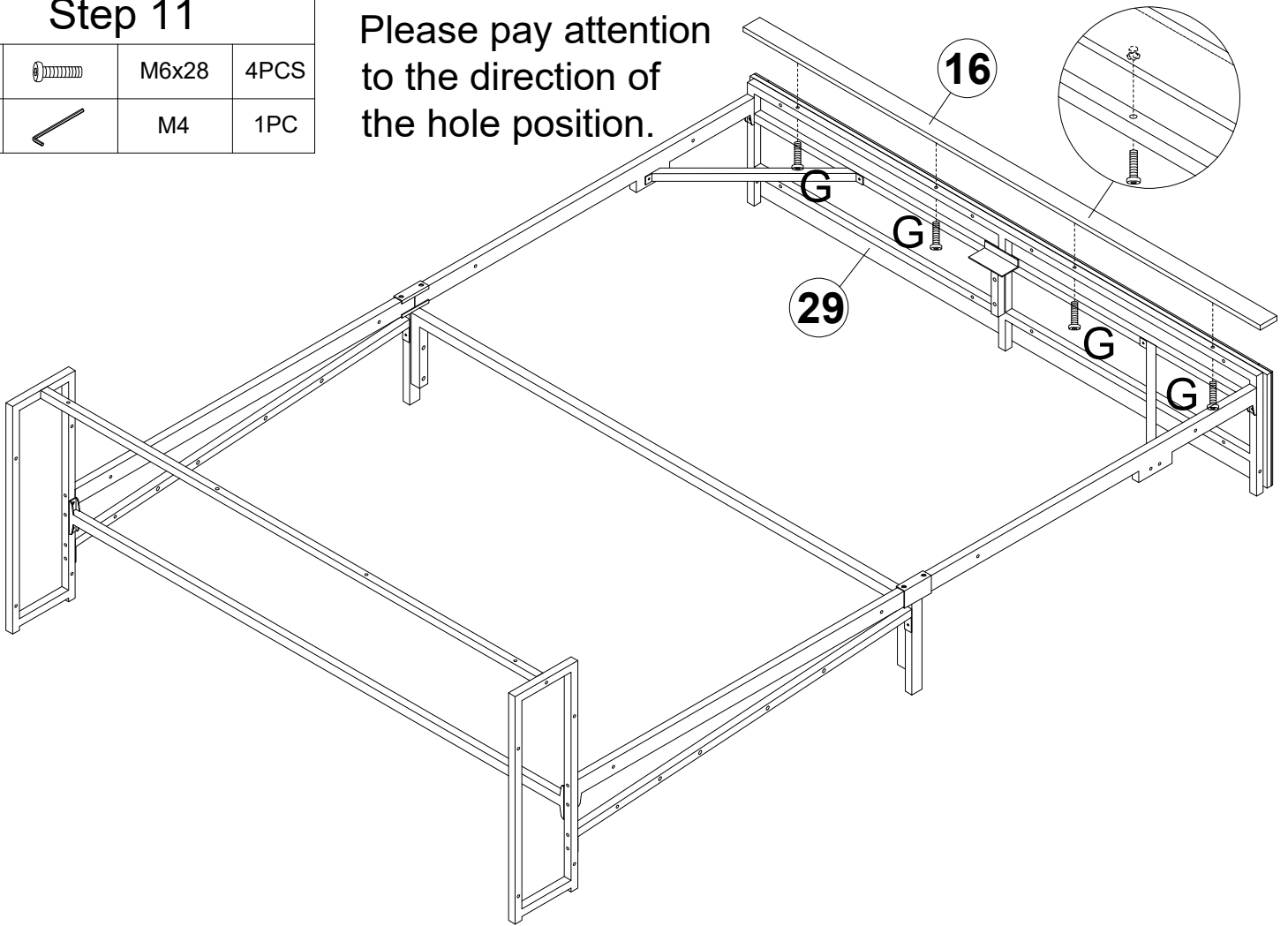
Please pay attention to the direction of the hole position.



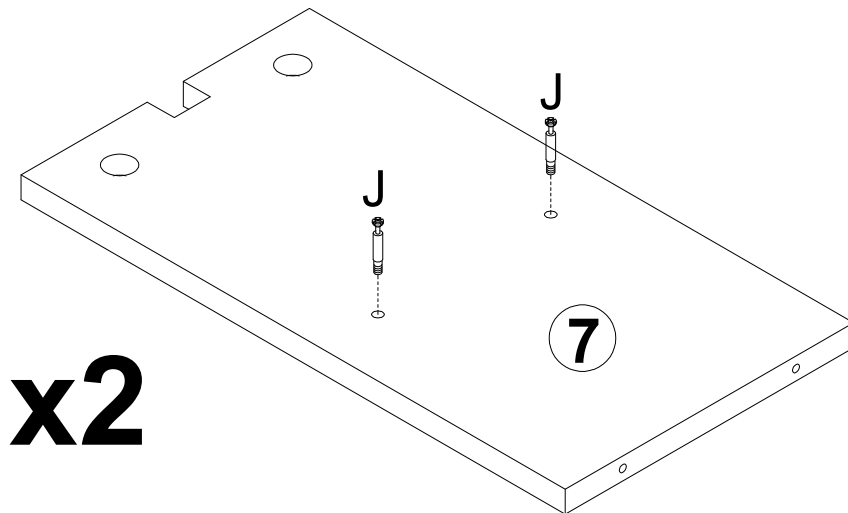

Step 12

J			4PCS
R		M4	1PC



Step 13

K			4PCS
R		M4	1PC

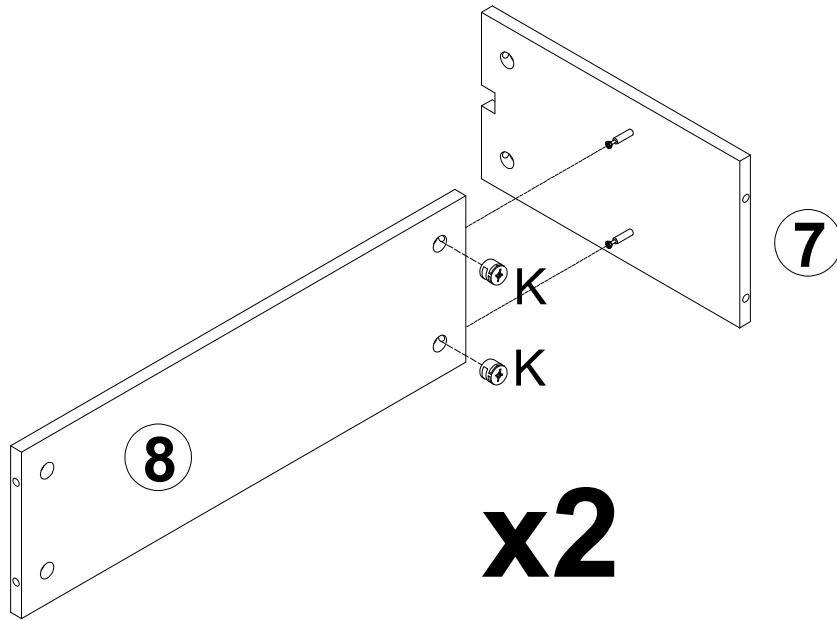

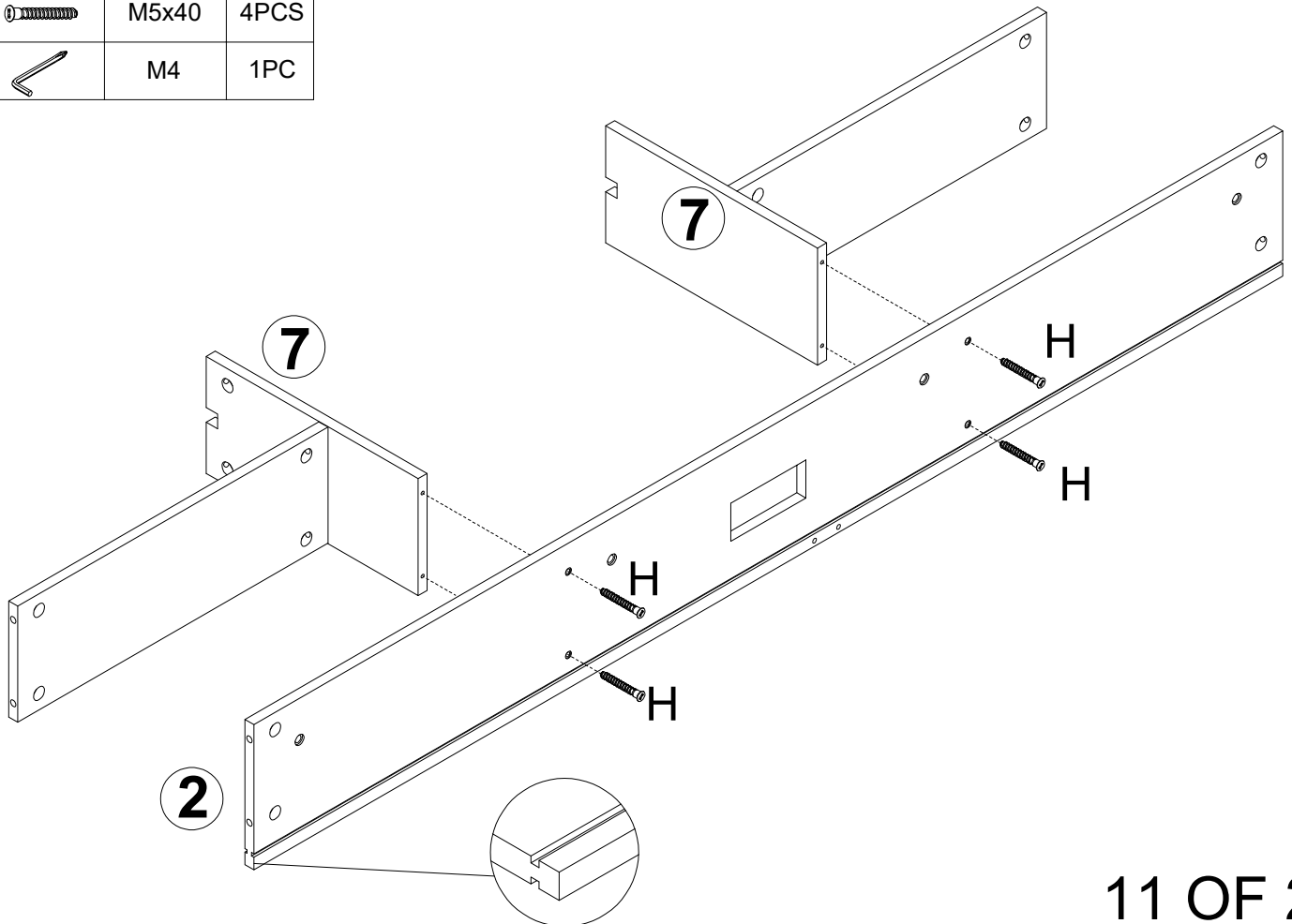

Step 14

H		M5x40	4PCS
R		M4	1PC



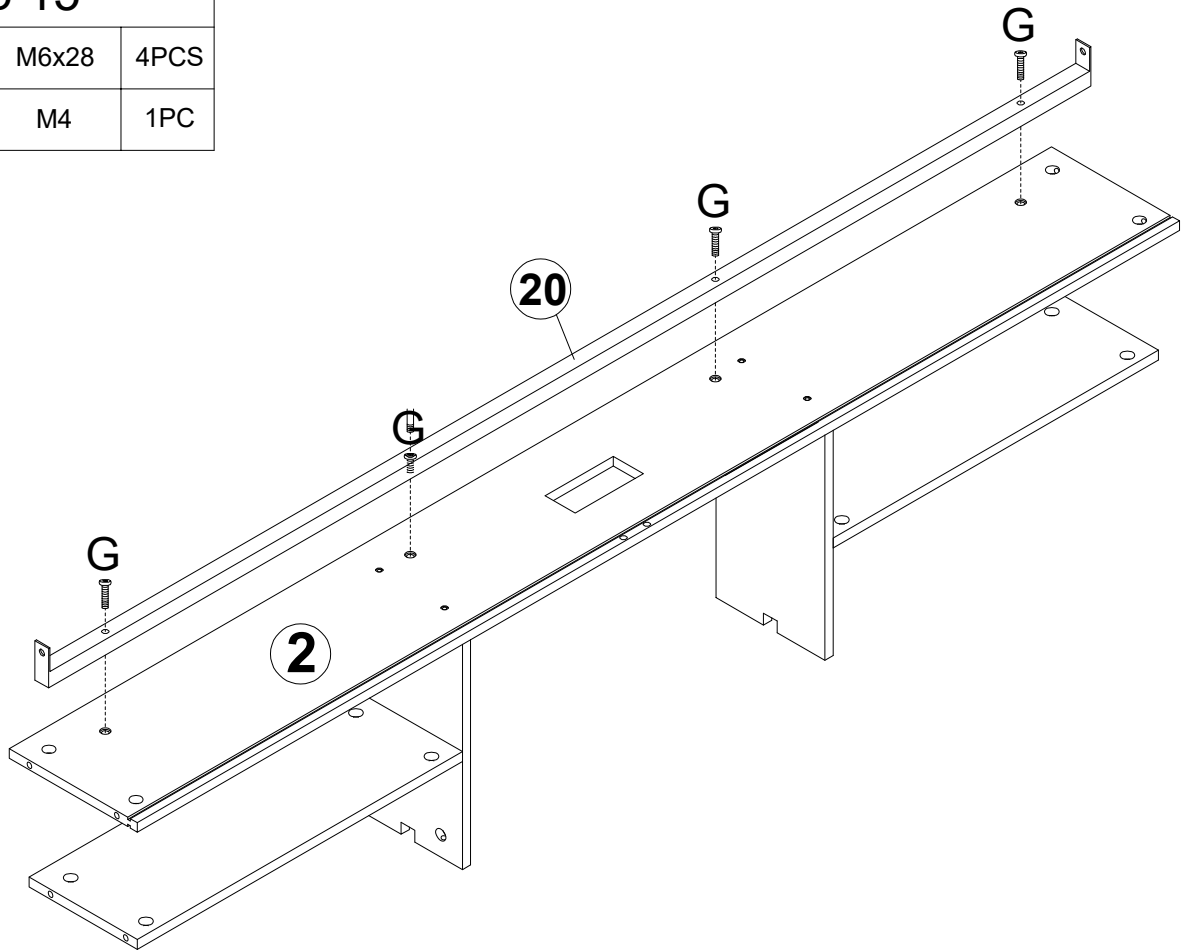

Step 15

G		M6x28	4PCS
S		M4	1PC



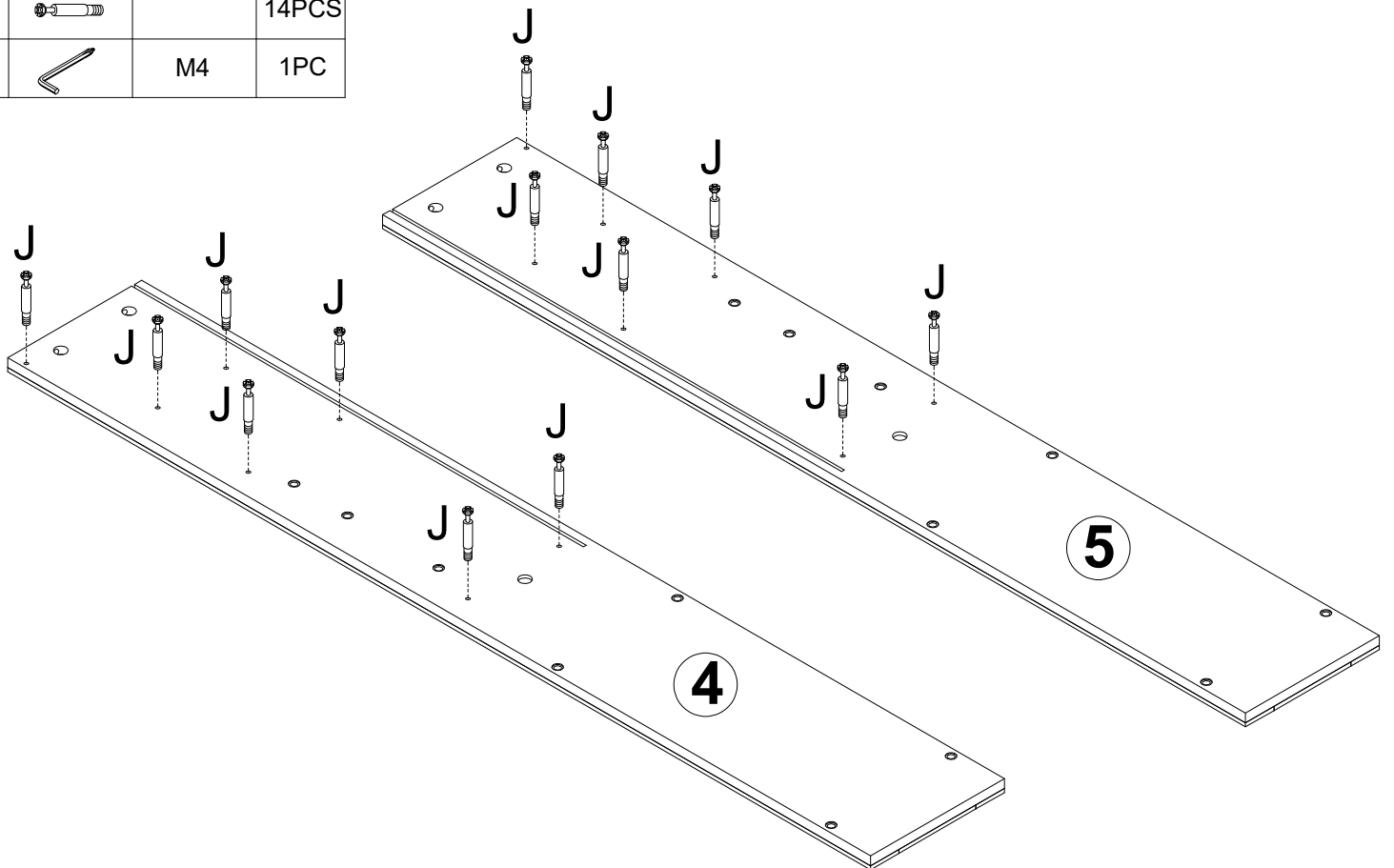

Step 16

J			14PCS
R		M4	1PC



Step 17

K			6PCS
Q		M6x10	1PCS
R		M4	1PC

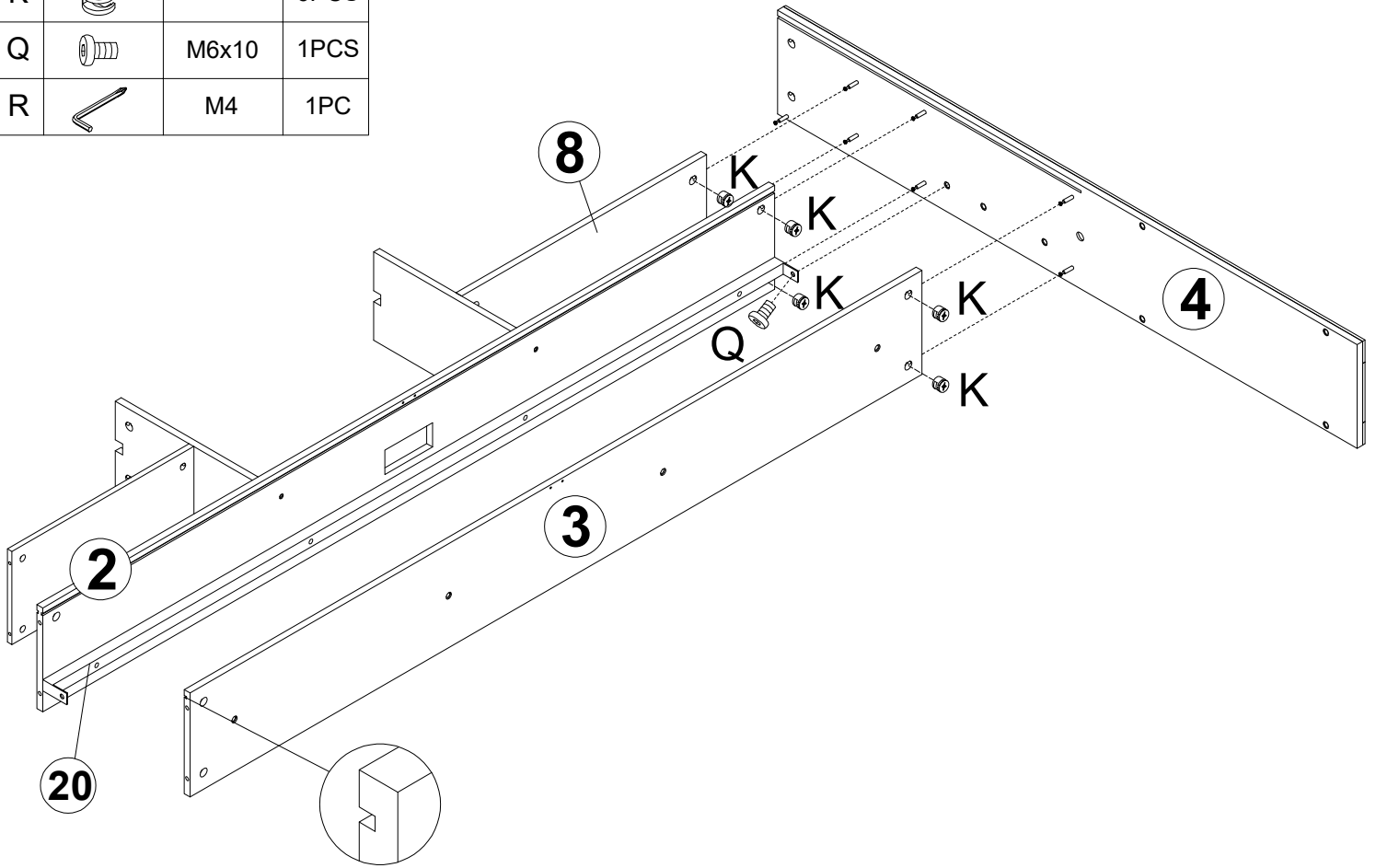

Step 18

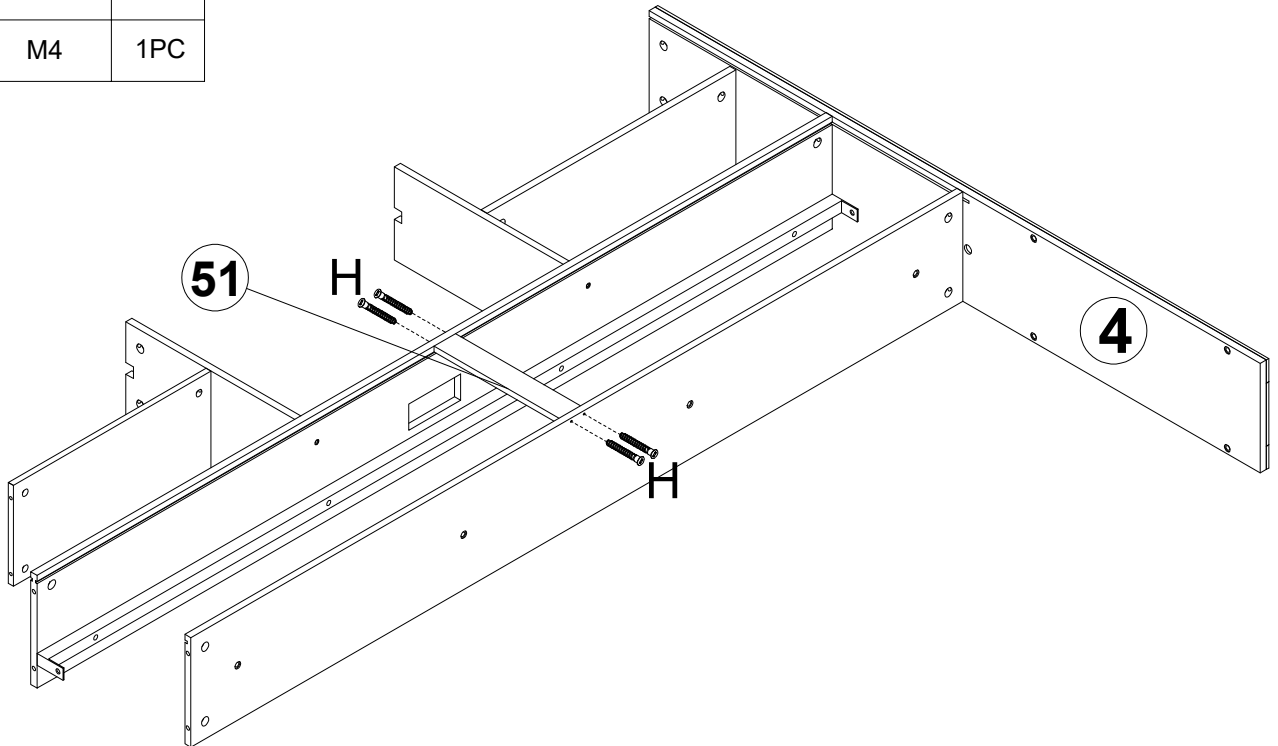

H		M5x40	4PCS
R		M4	1PC

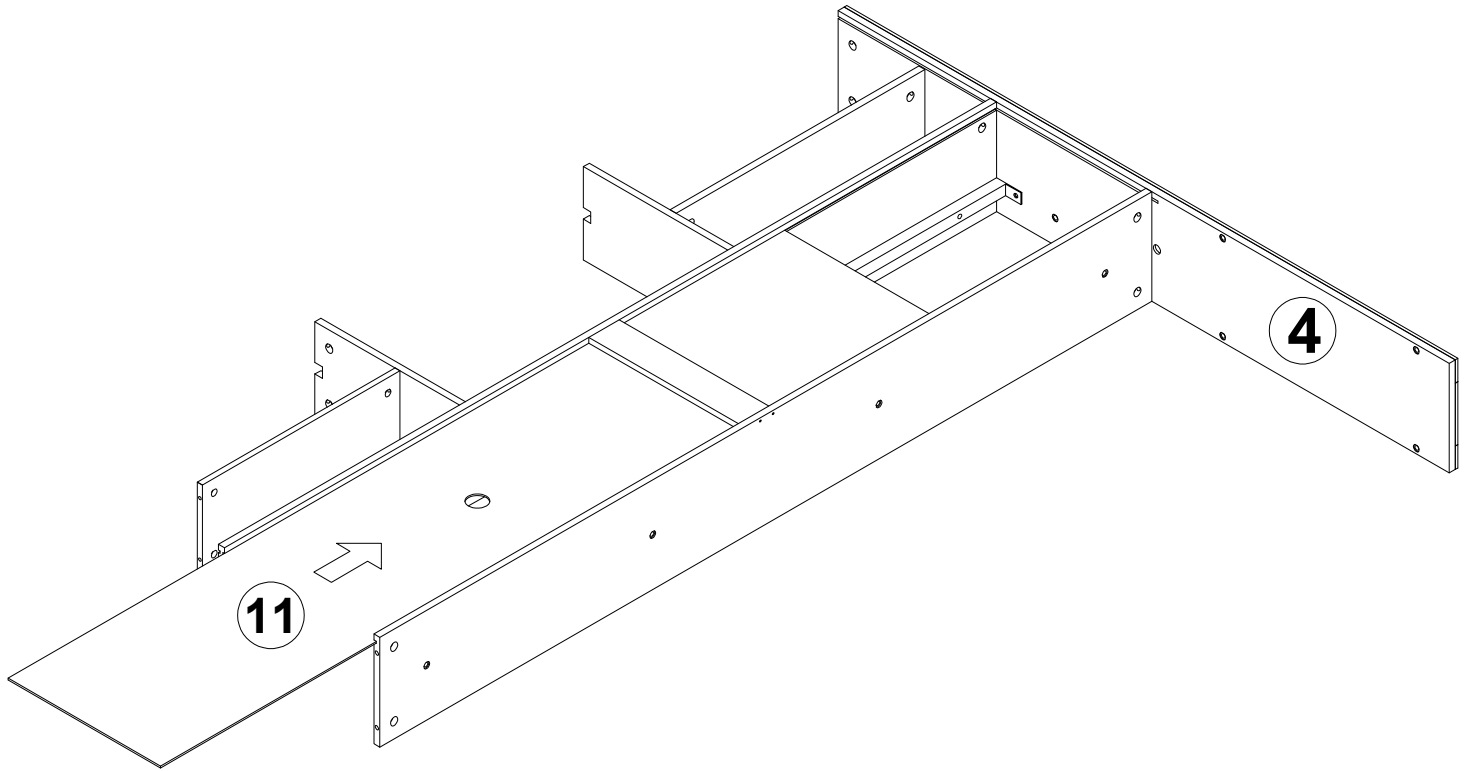

Step 19



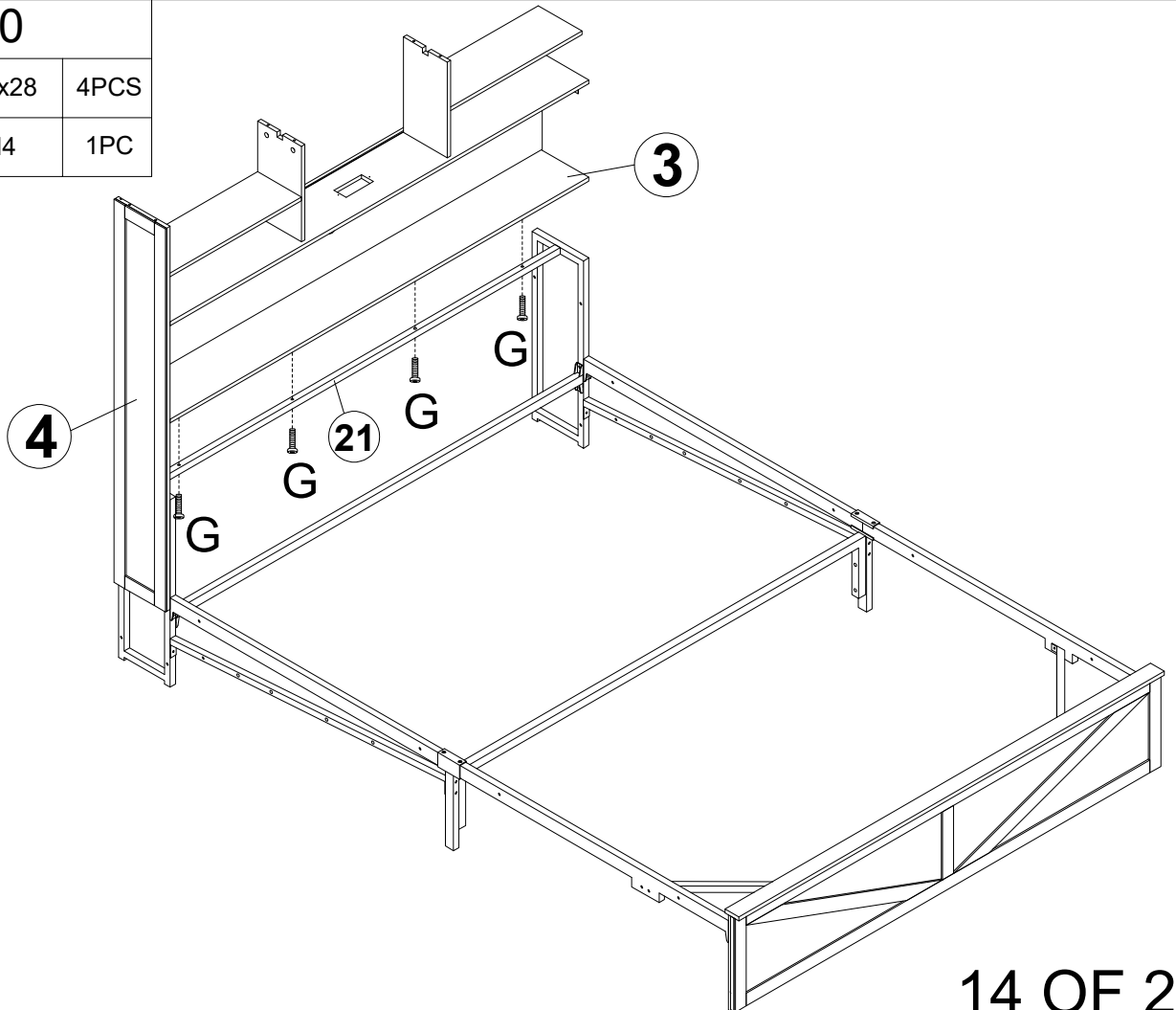

Step 20

G		M6x28	4PCS
S		M4	1PC



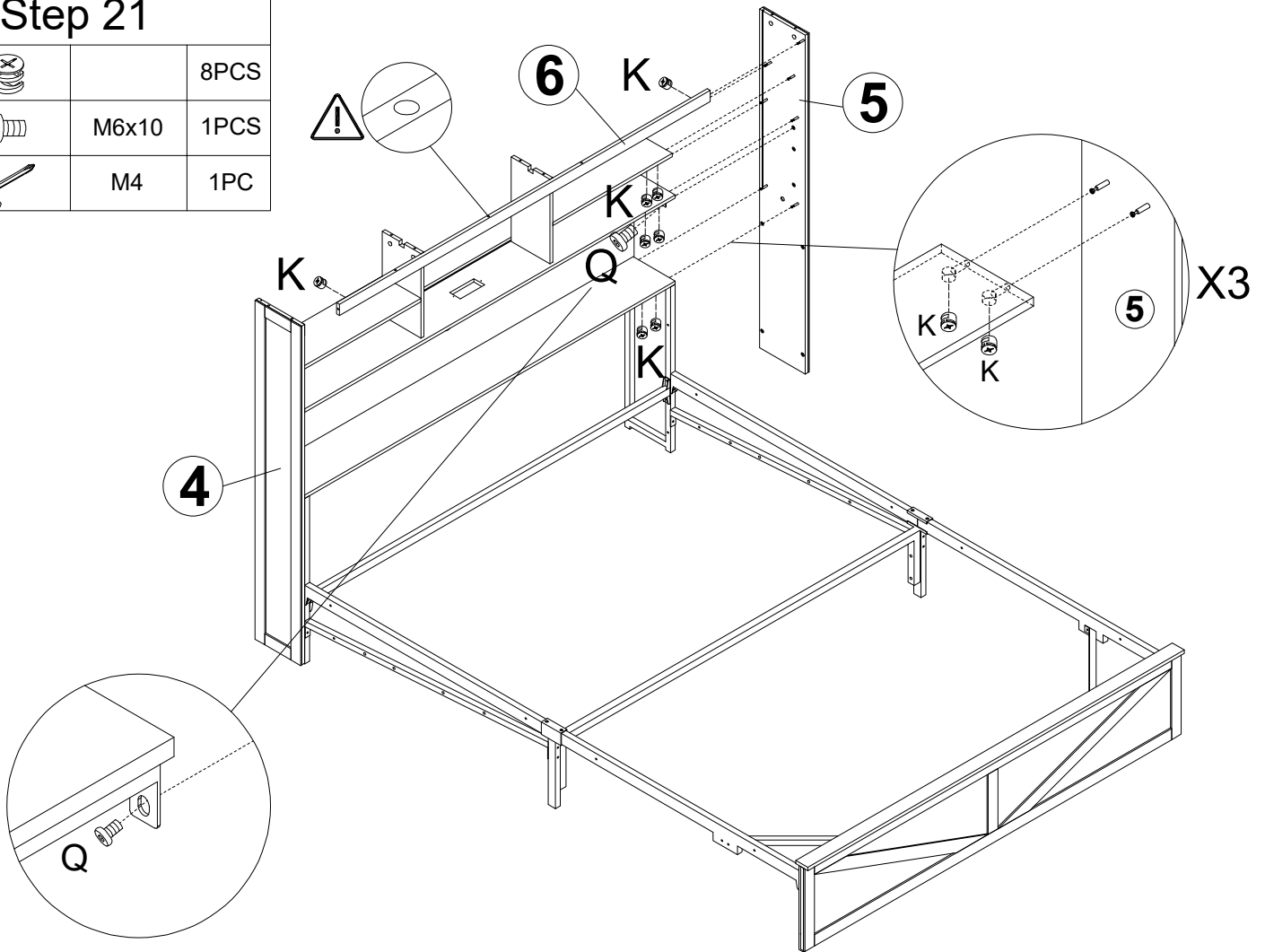

Step 21

K			8PCS
Q		M6x10	1PCS
R		M4	1PC



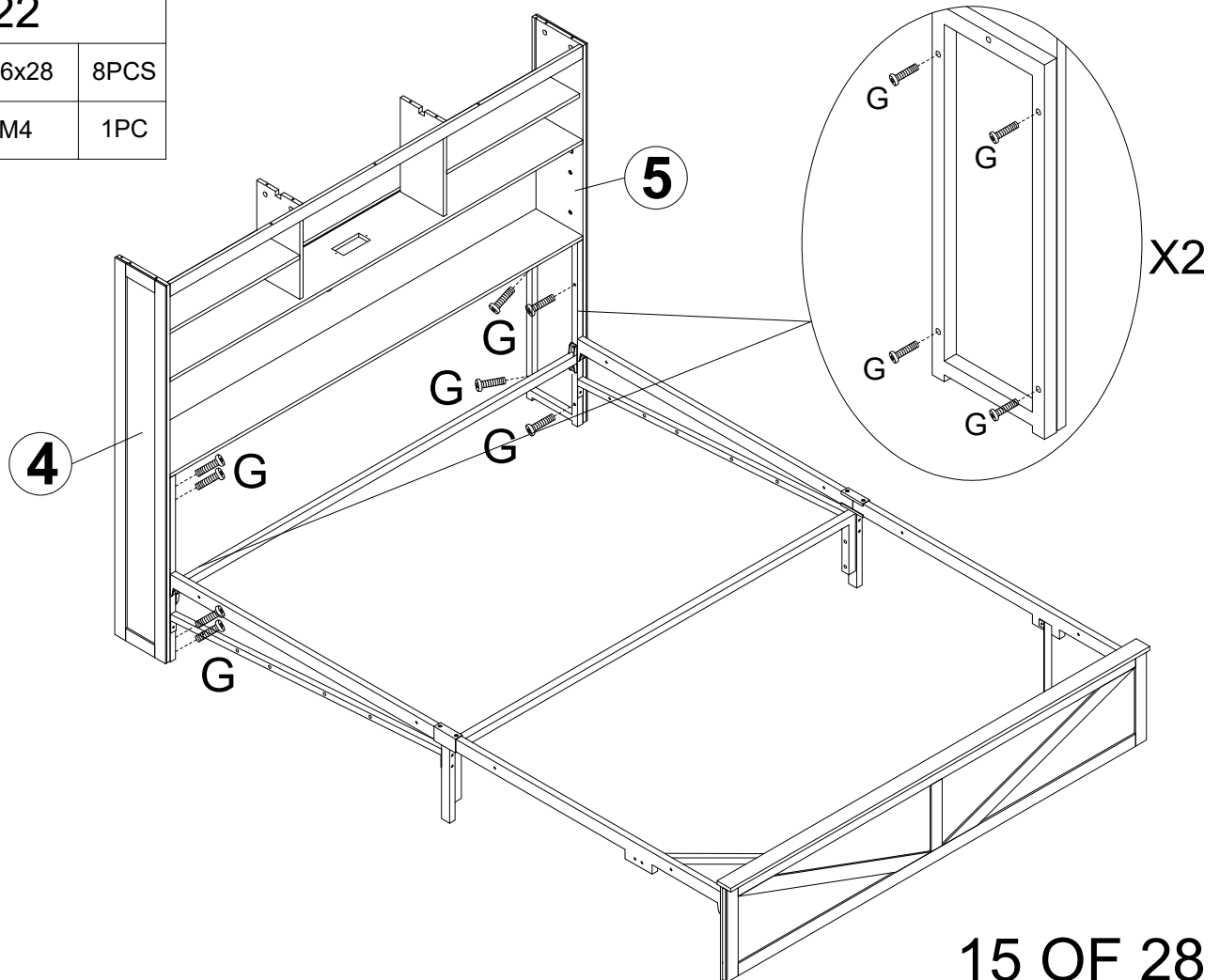

Step 22

G		M6x28	8PCS
S		M4	1PC



Step 23

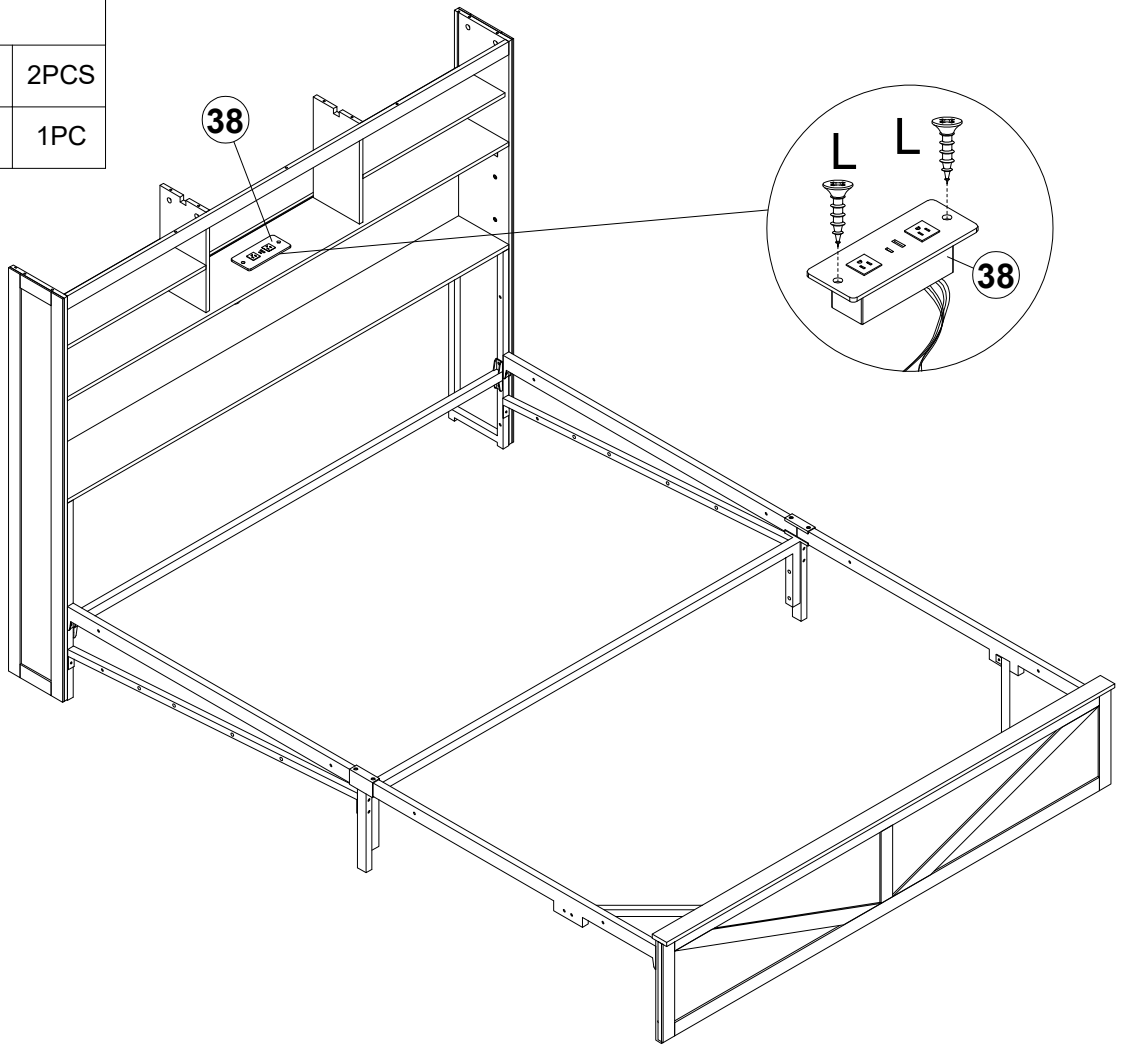

L		M3.5x12	2PCS
R		M4	1PC

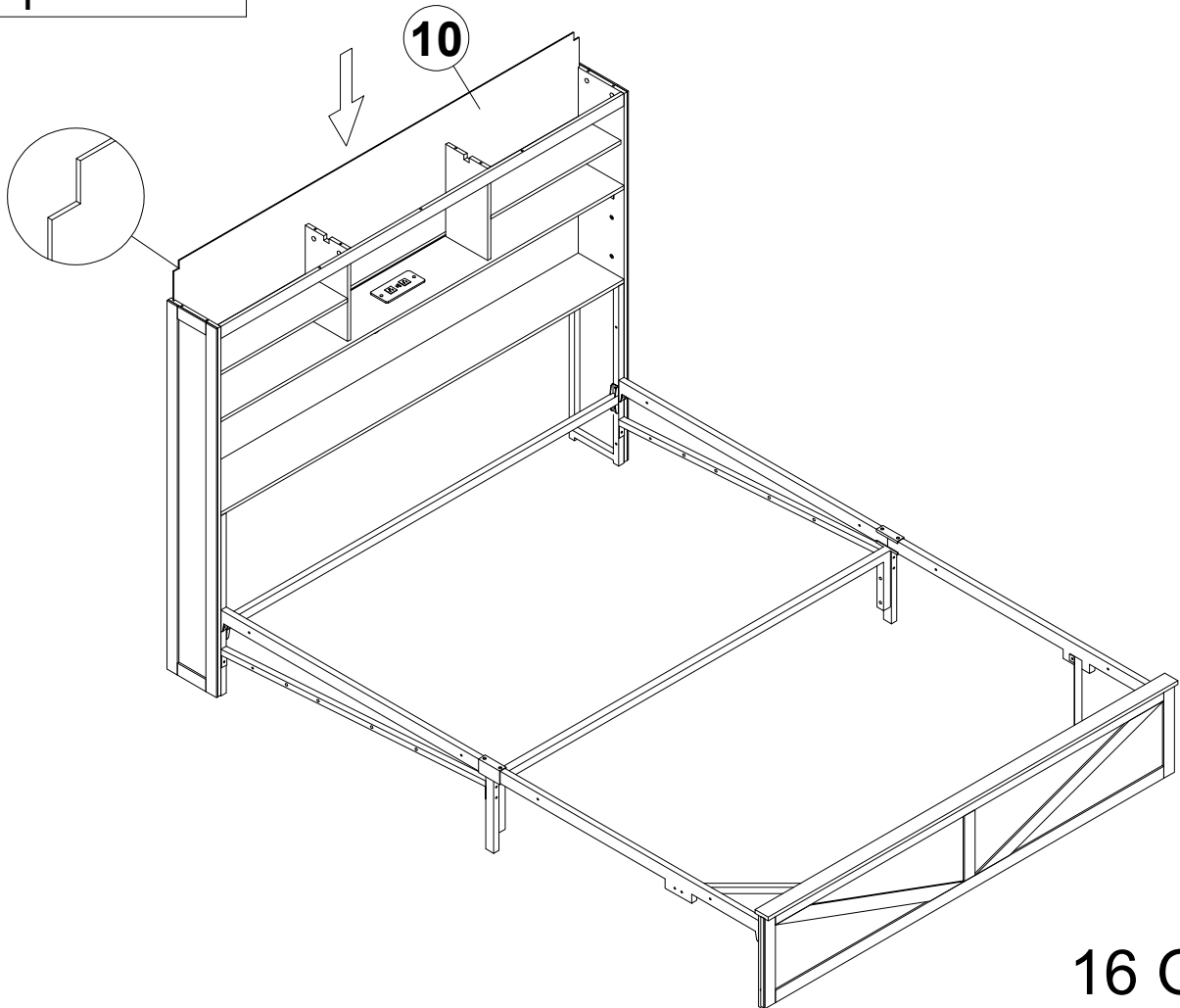

Step 24



Step 25

I			4PCS
L		M3.5x12	4PCS
R		M4	1PC

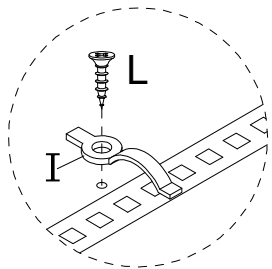

X4

Option 1

39

1

39

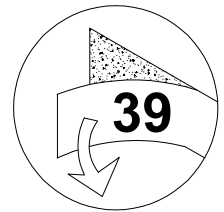

1

Option 2



Tear off the back glue of the light strip.

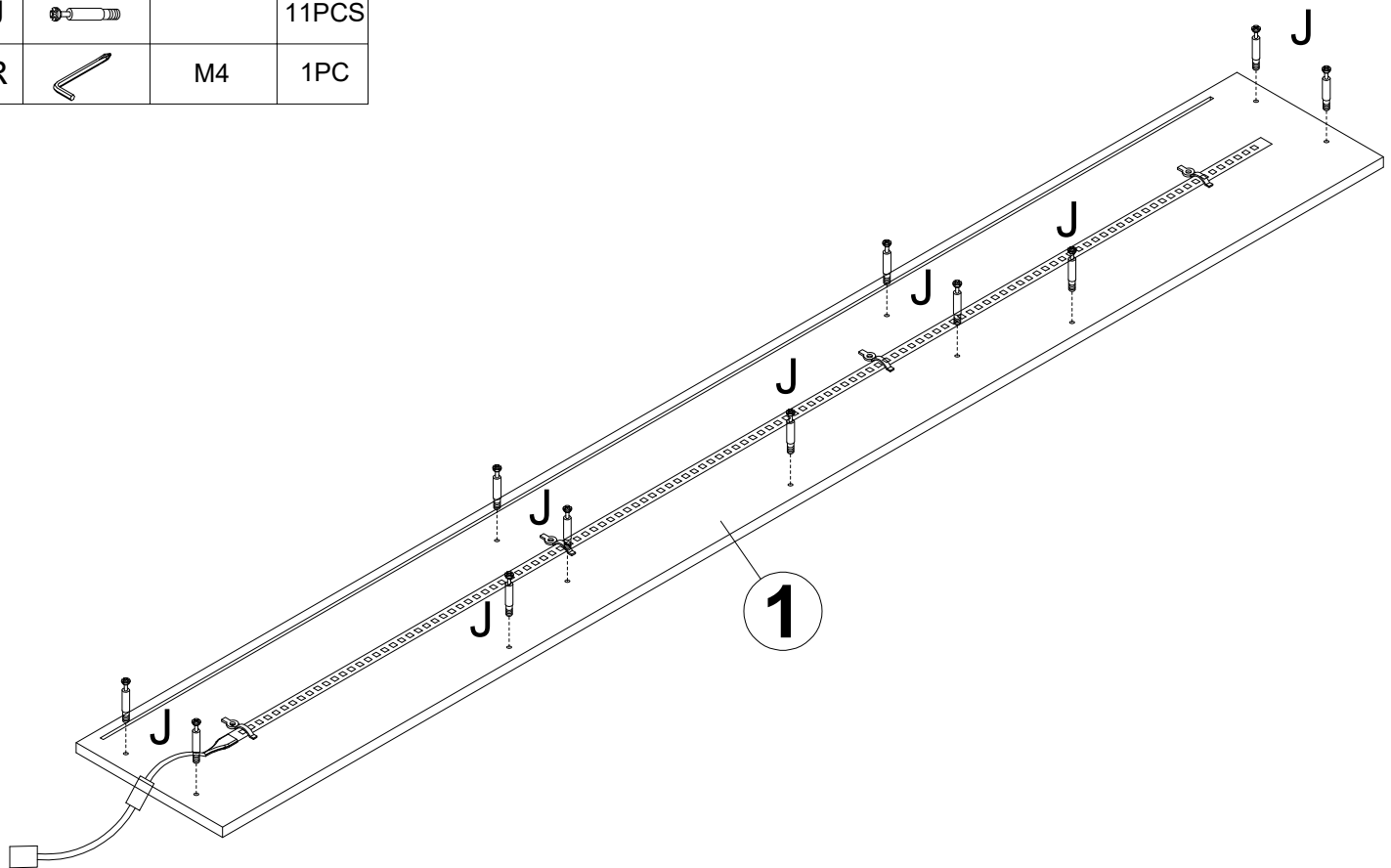

Step 26

J			11PCS
R		M4	1PC





1

Step 27

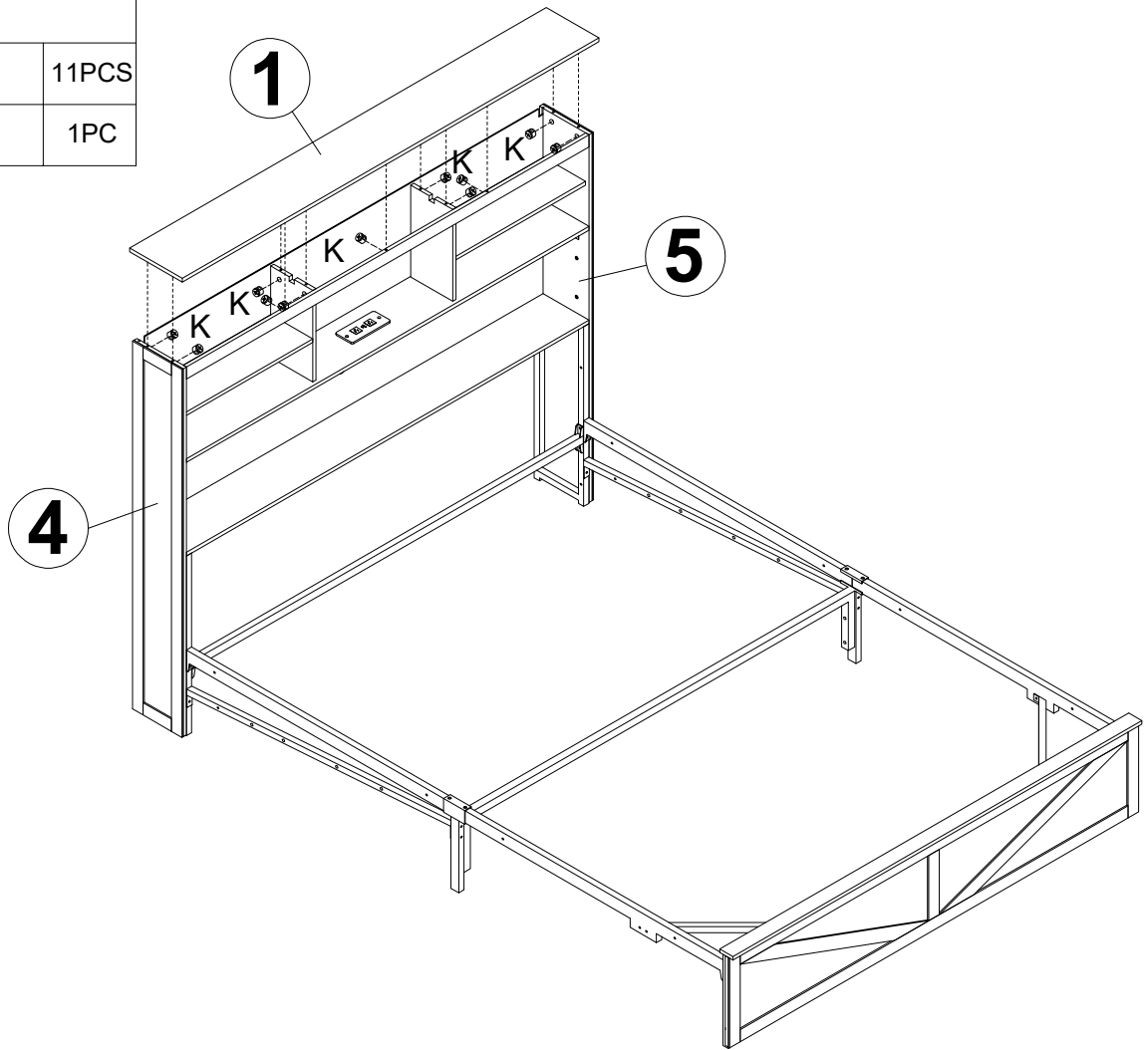
K			11PCS
R		M4	1PC



Step 28

Q		M6x10	4PCS
S		M4	1PC

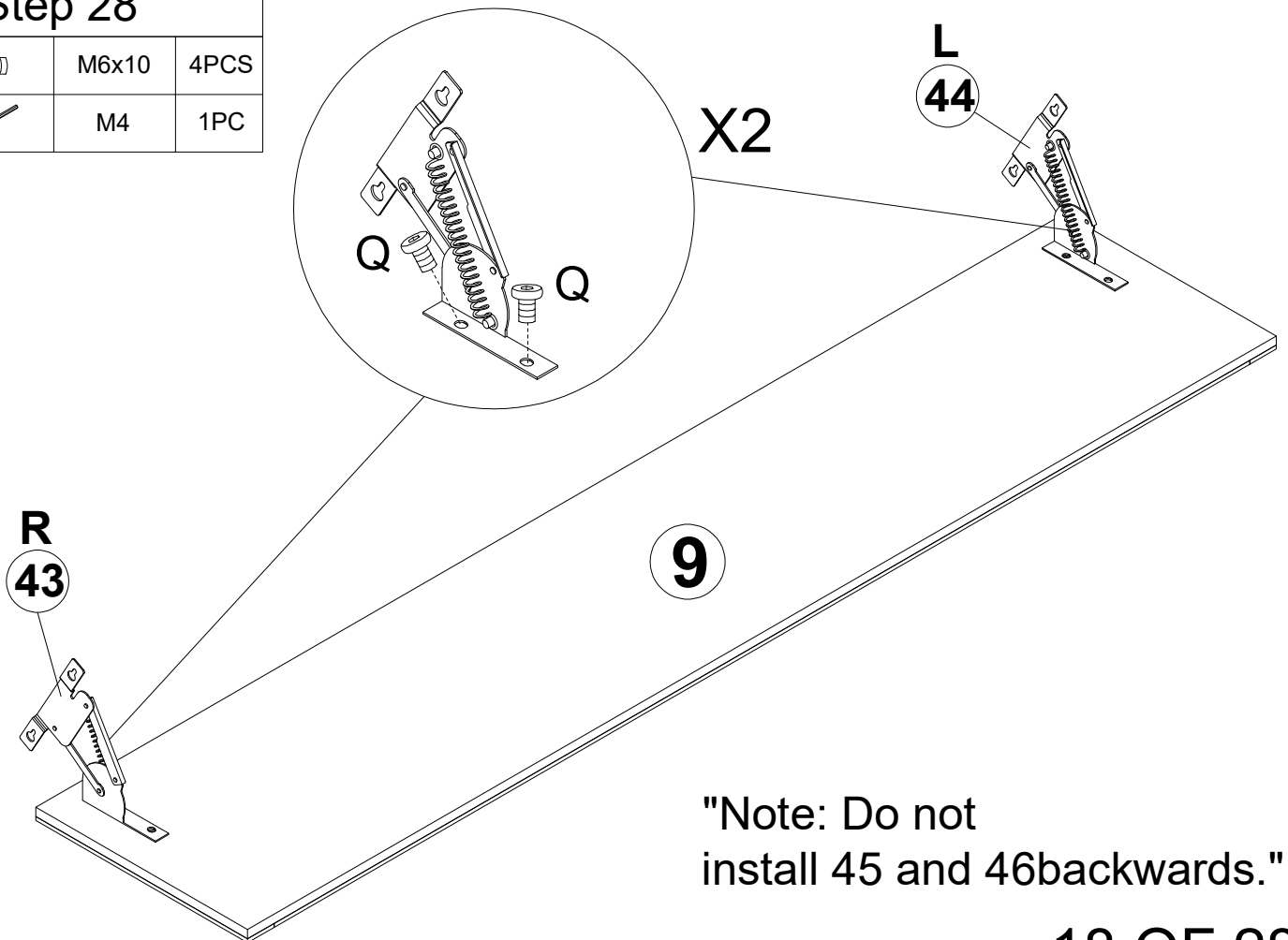

"Note: Do not install 45 and 46 backwards."

Step 29



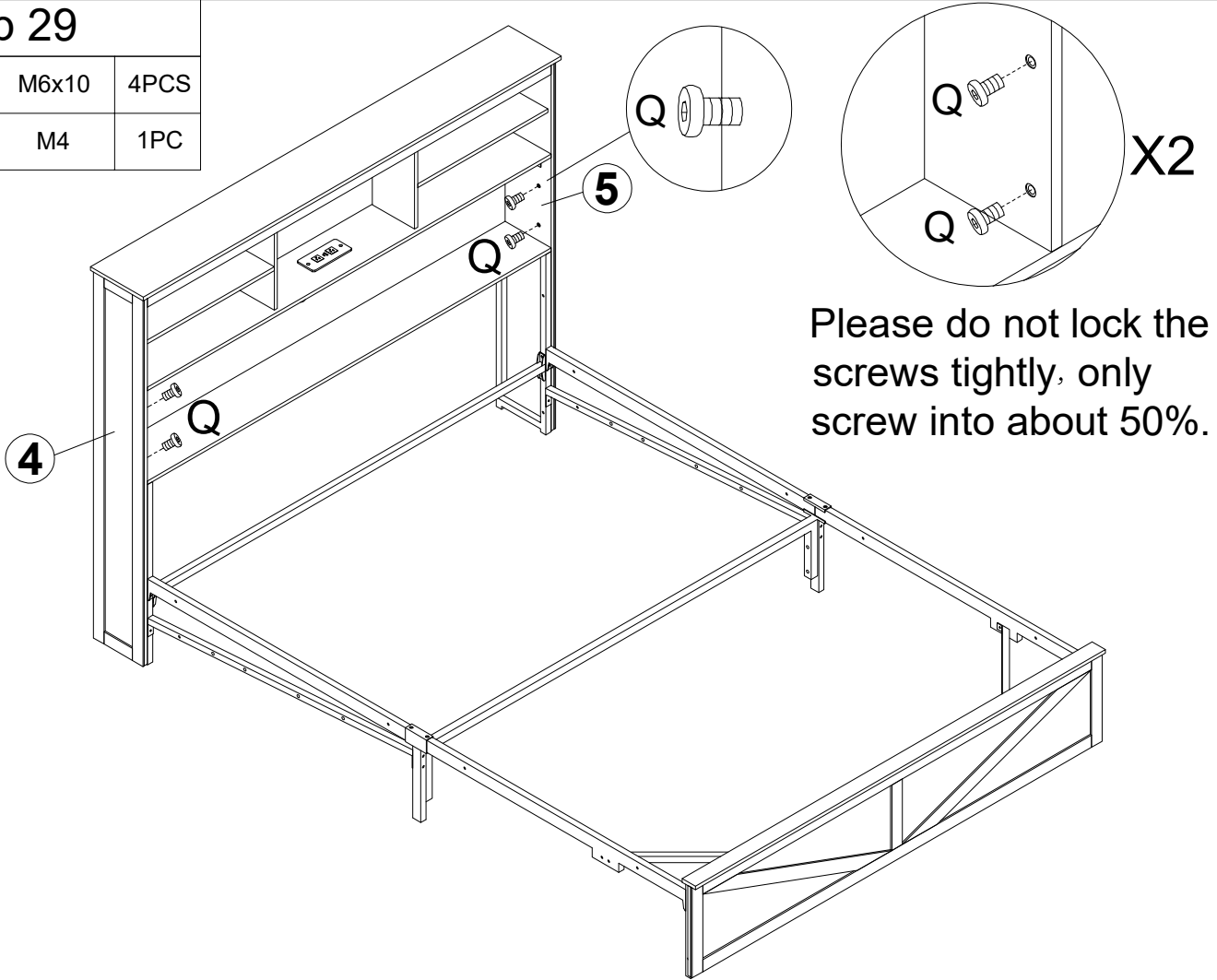

Q		M6x10	4PCS
S		M4	1PC

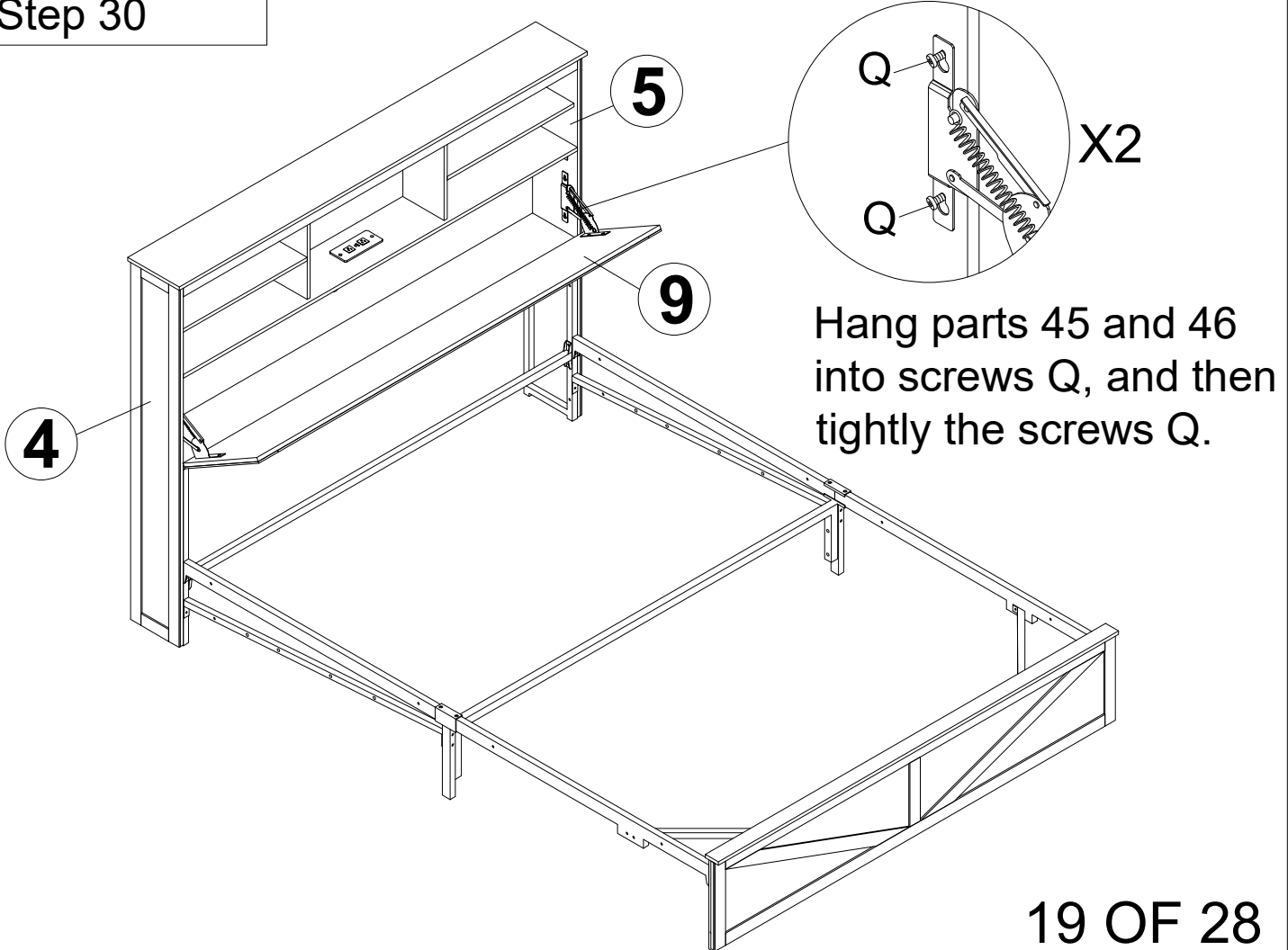

Step 30



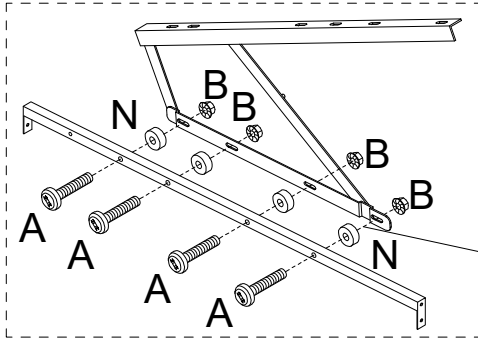
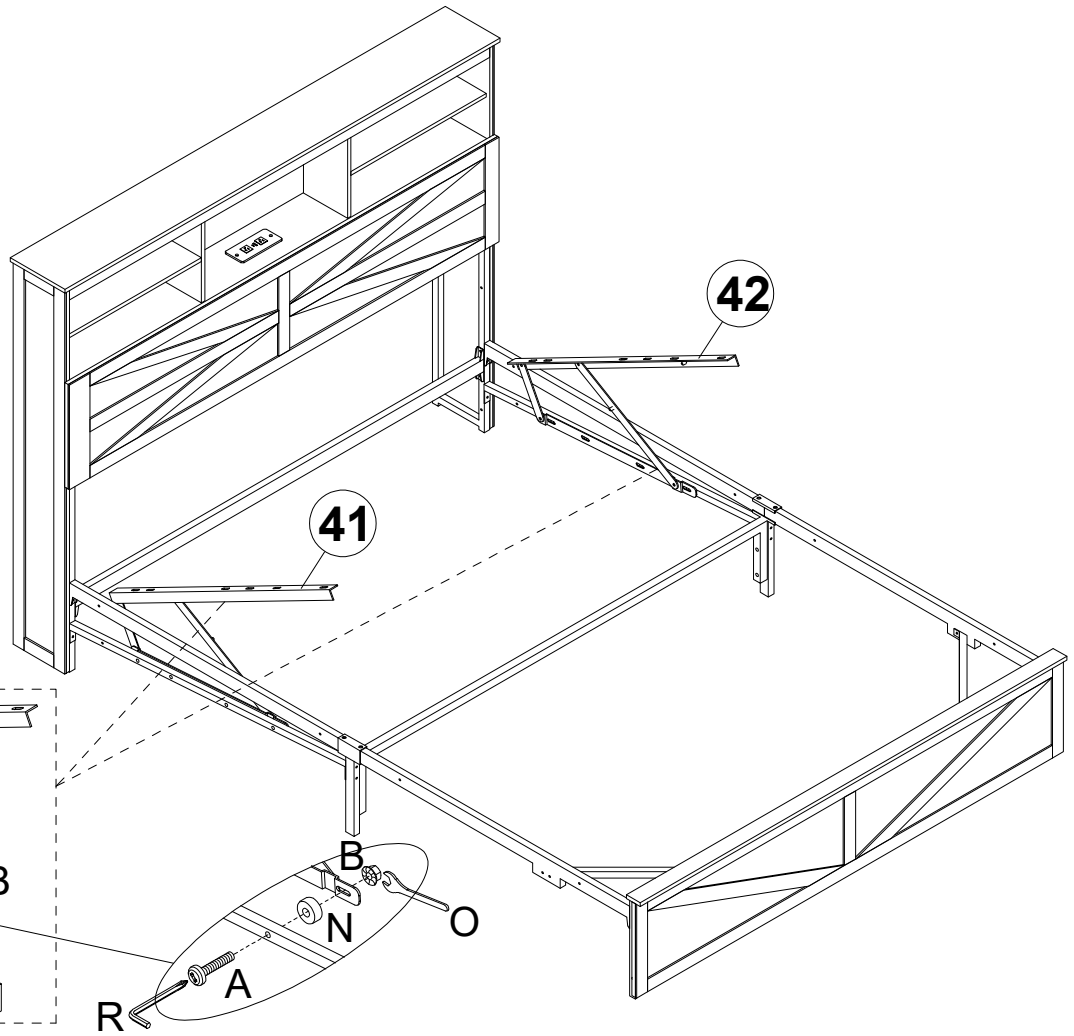

Step 31

A		M8x45	8PCS
B			8PCS
N			8PCS
R		M4	1PC
O			1PC



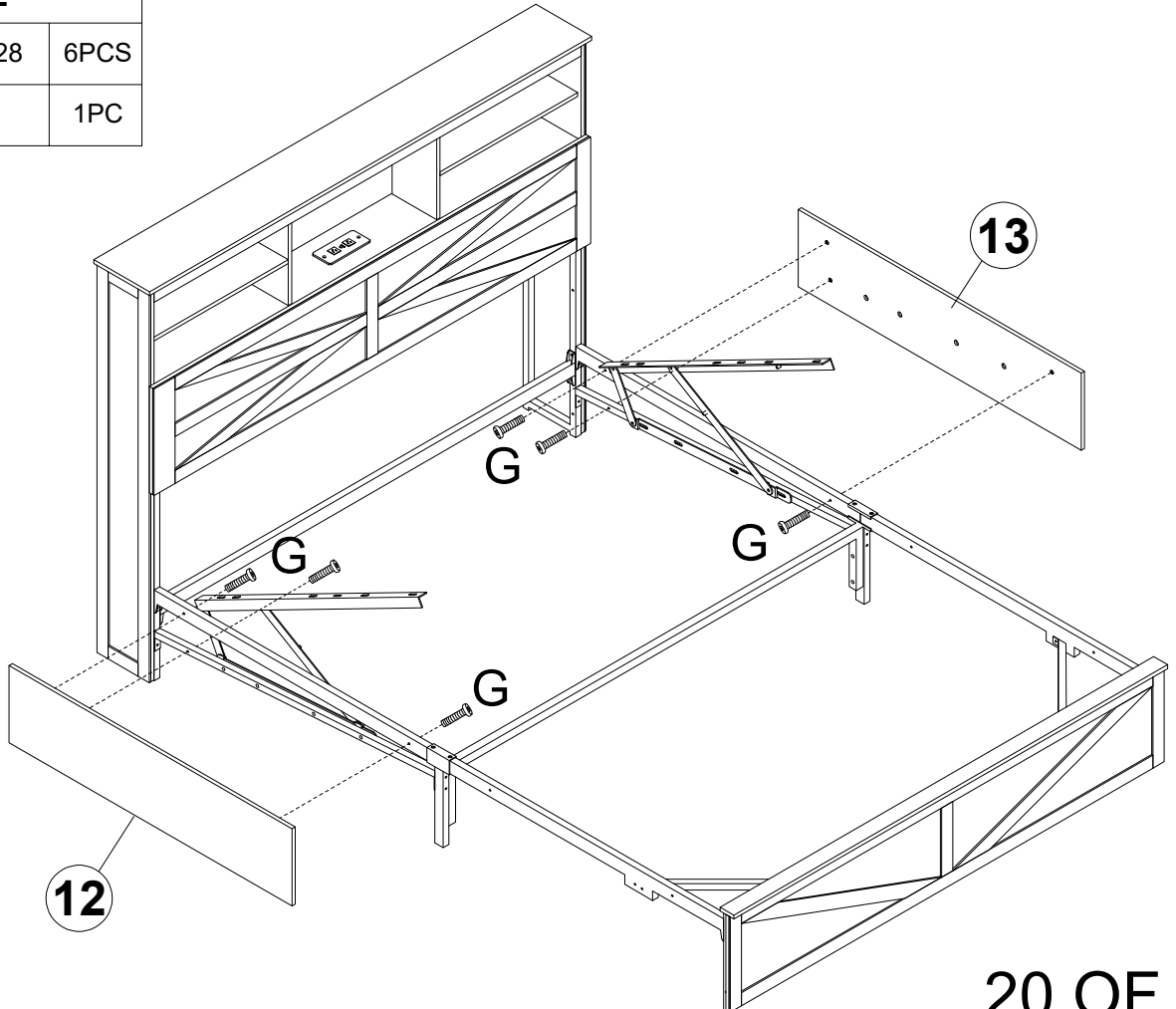

Step 32

G		M6x28	6PCS
S		M4	1PC



Step 33

G		M6x28	6PCS
S		M4	1PC

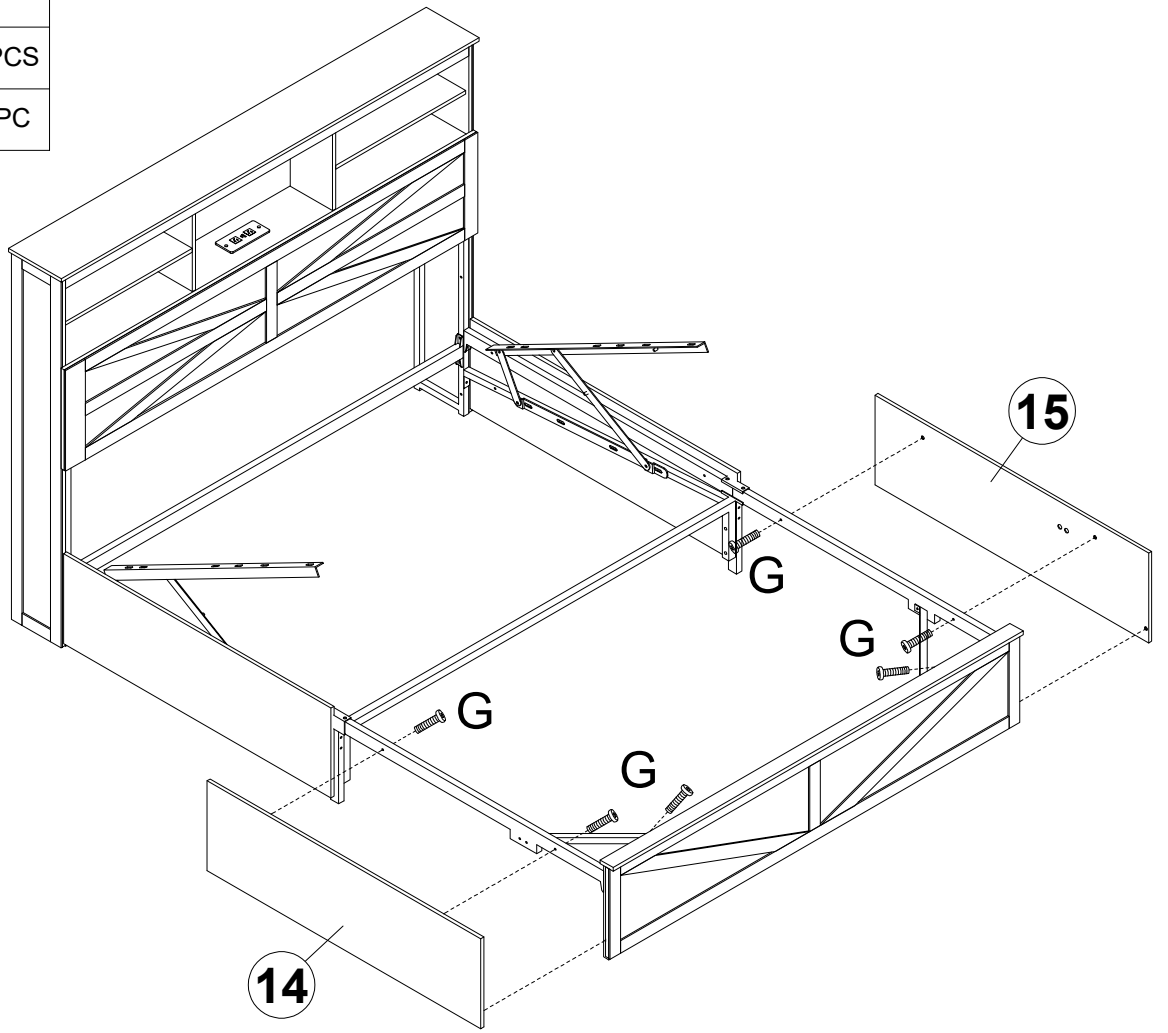

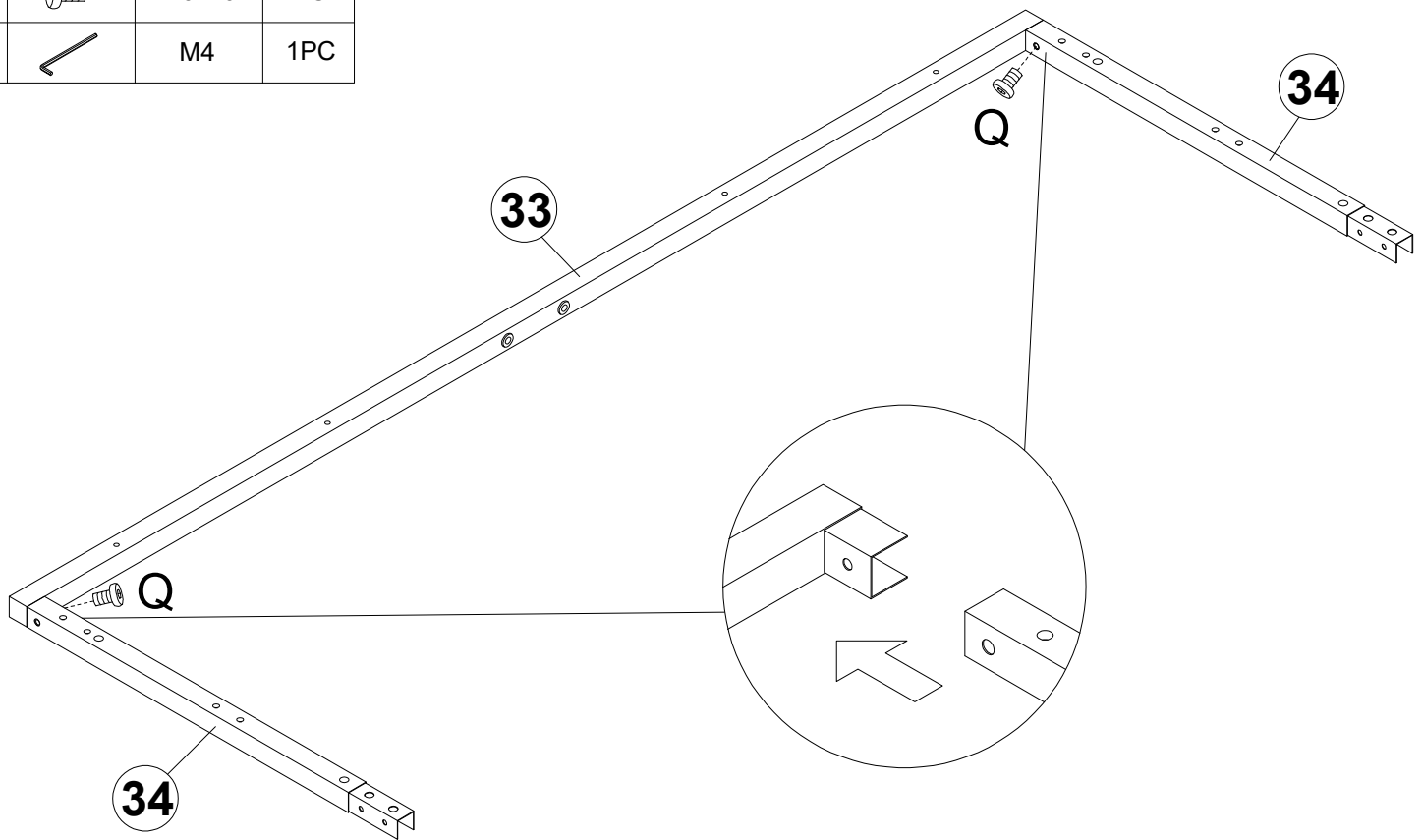

Step 34

Q		M6x10	2PCS
S		M4	1PC



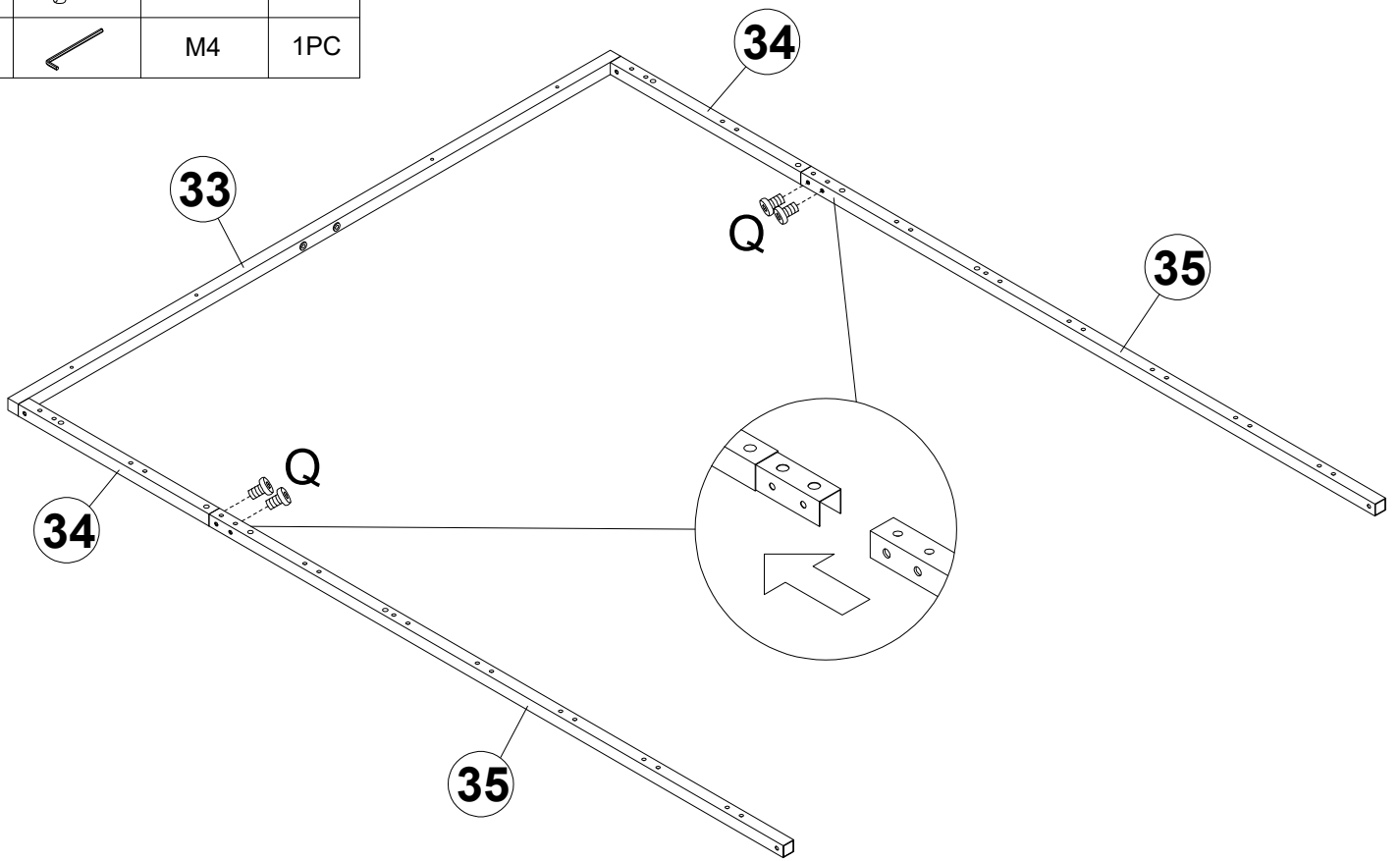

Step 35

Q		M6x10	4PCS
S		M4	1PC



Step 36

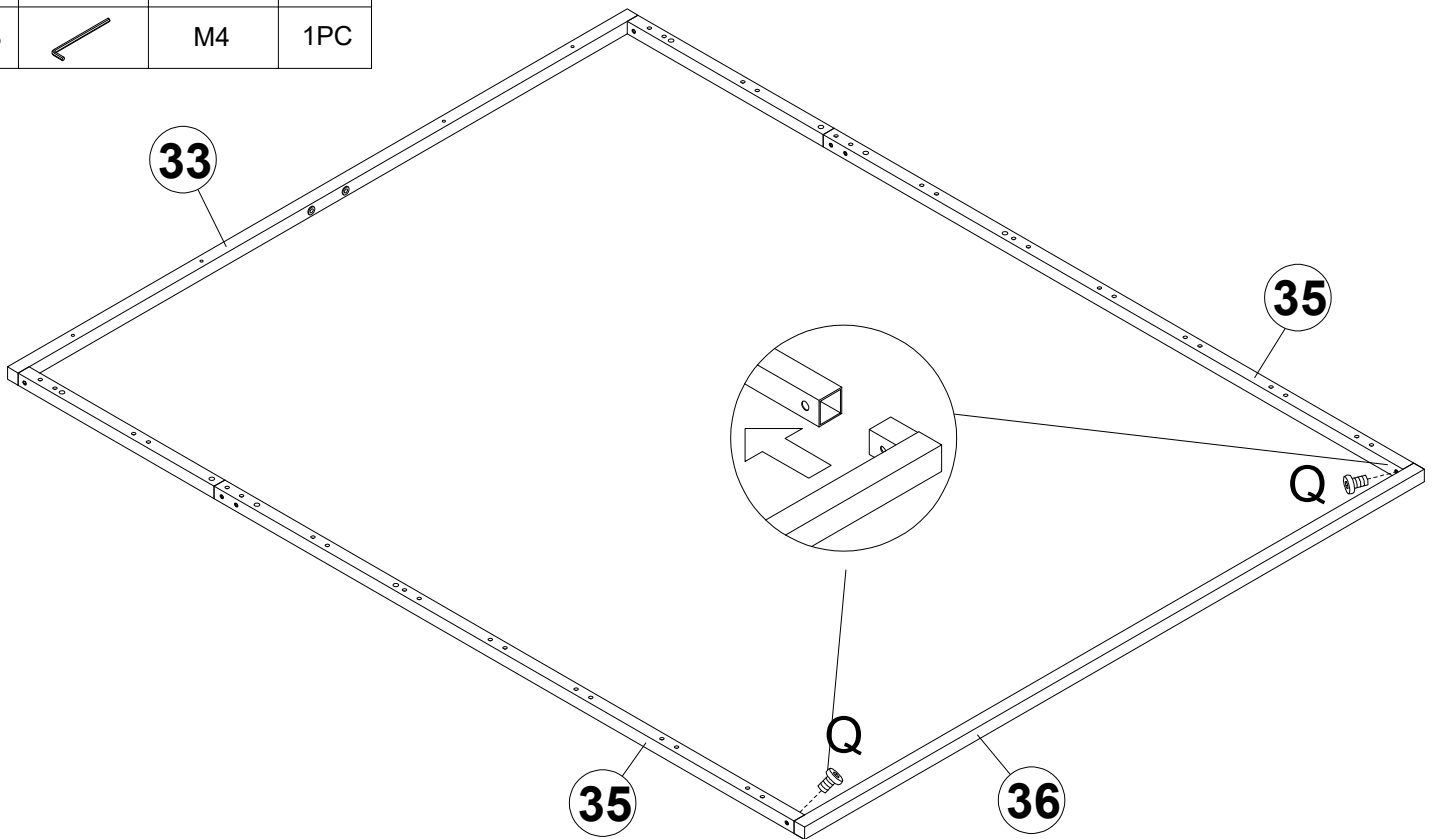

Q		M6x10	2PCS
S		M4	1PC

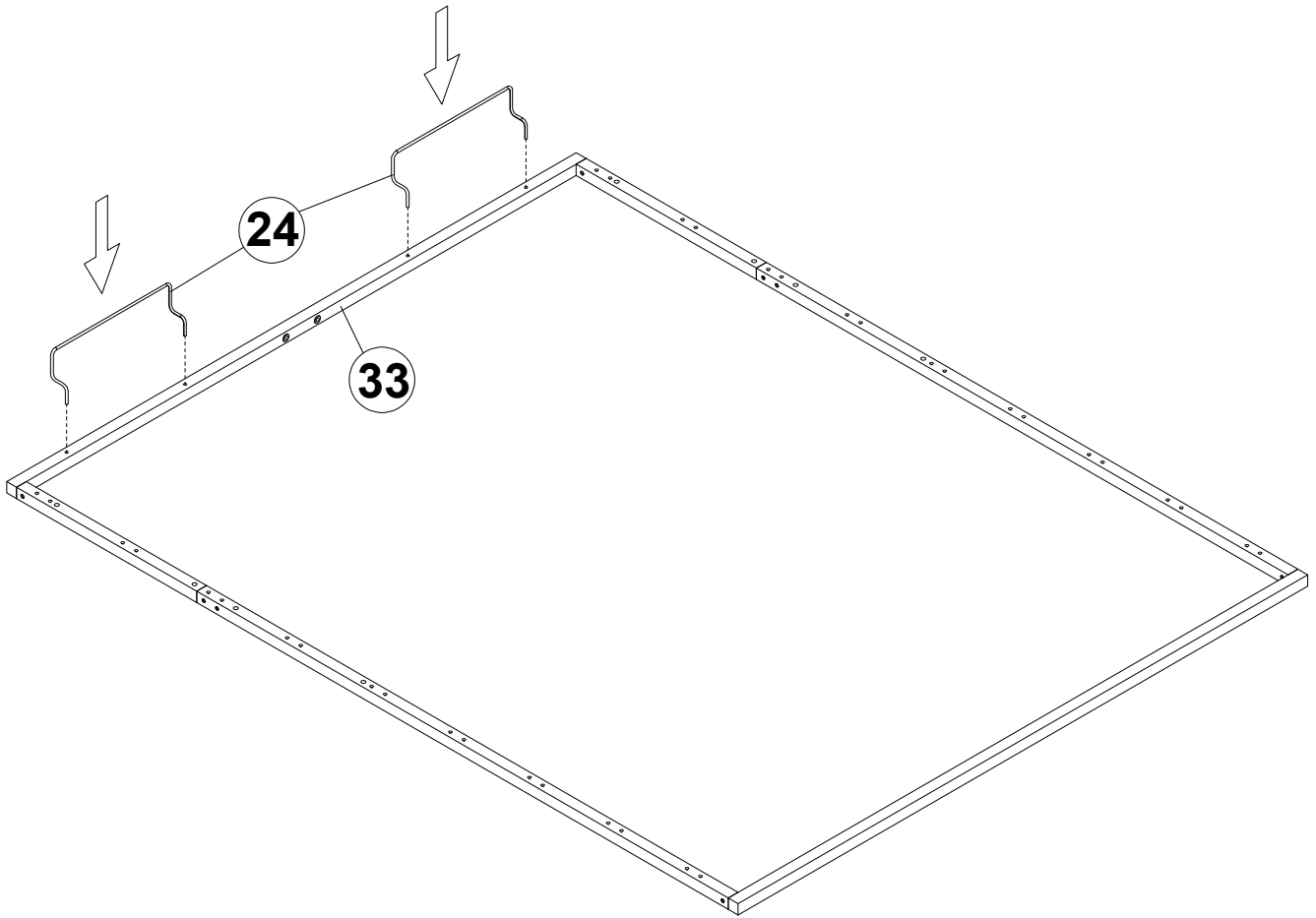

Step 37



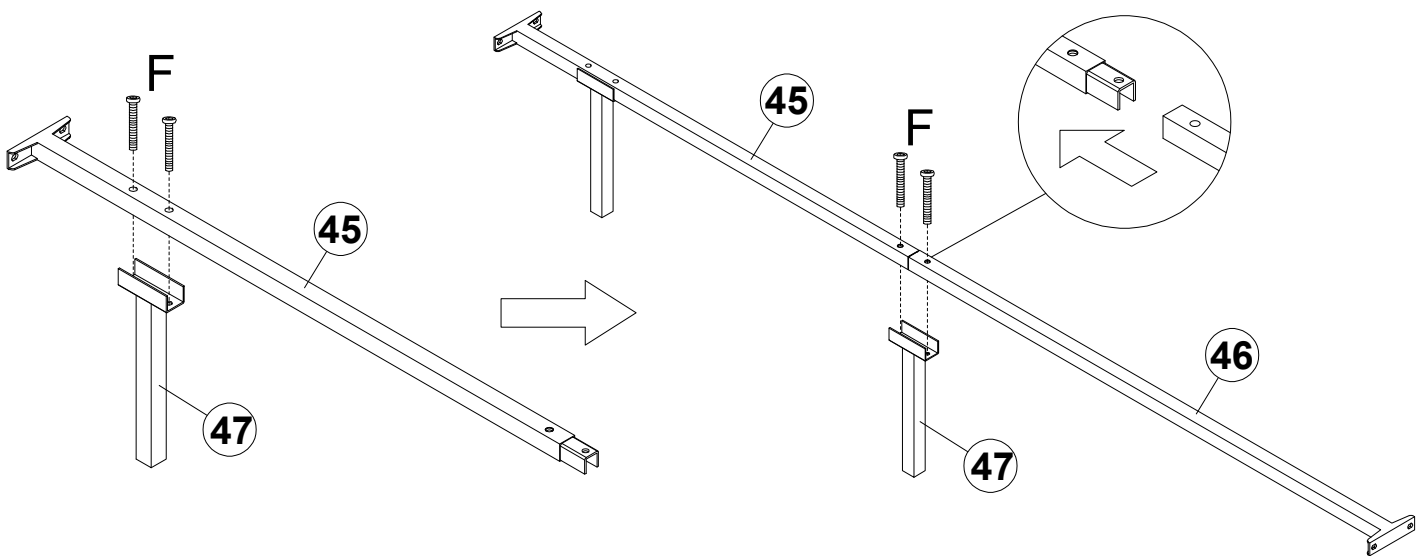

Step 38

F		M8x35	4PCS
T		M5	1PC



Step 39

V		M8x16	4PCS
T		M5	1PC

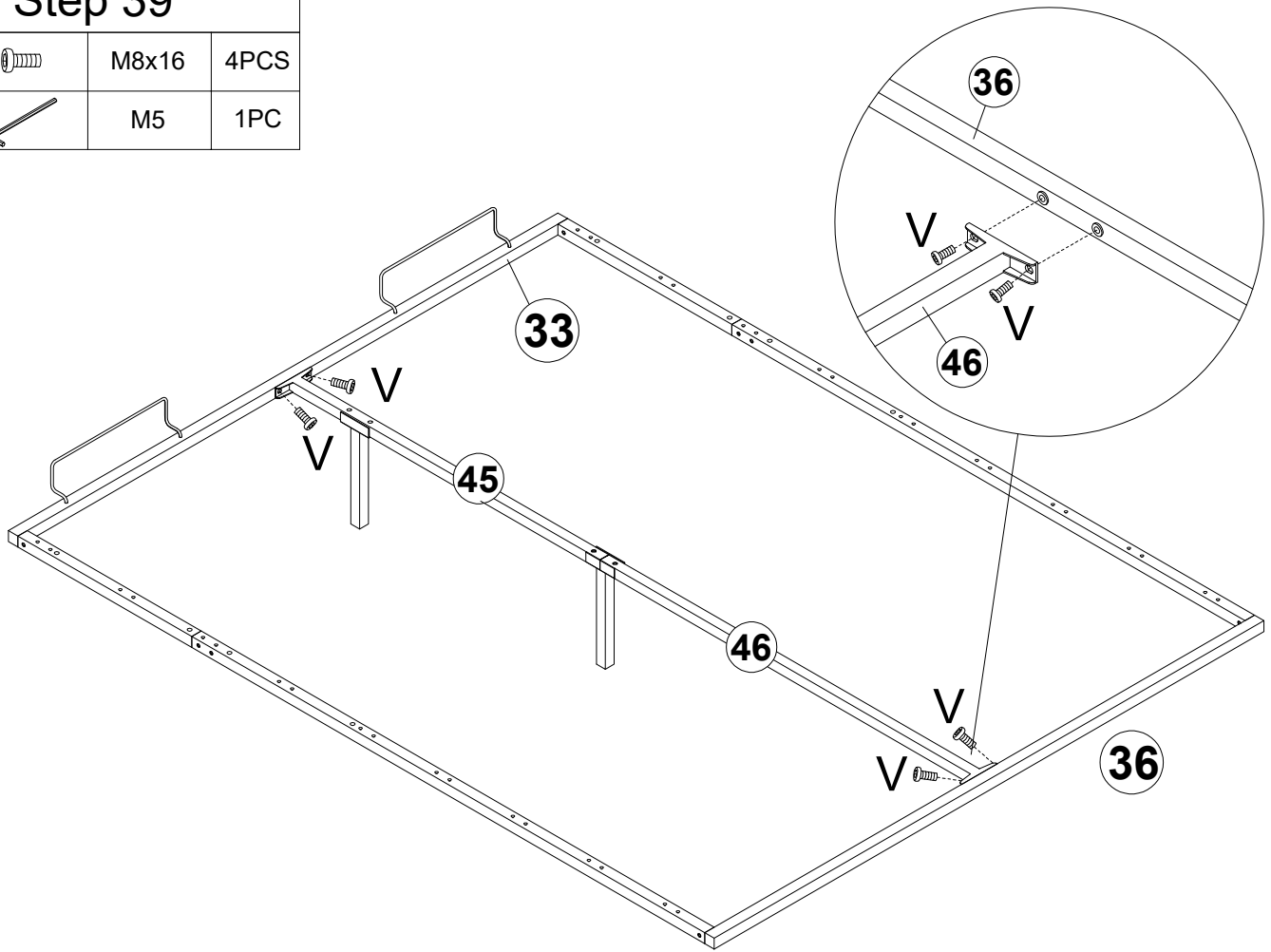



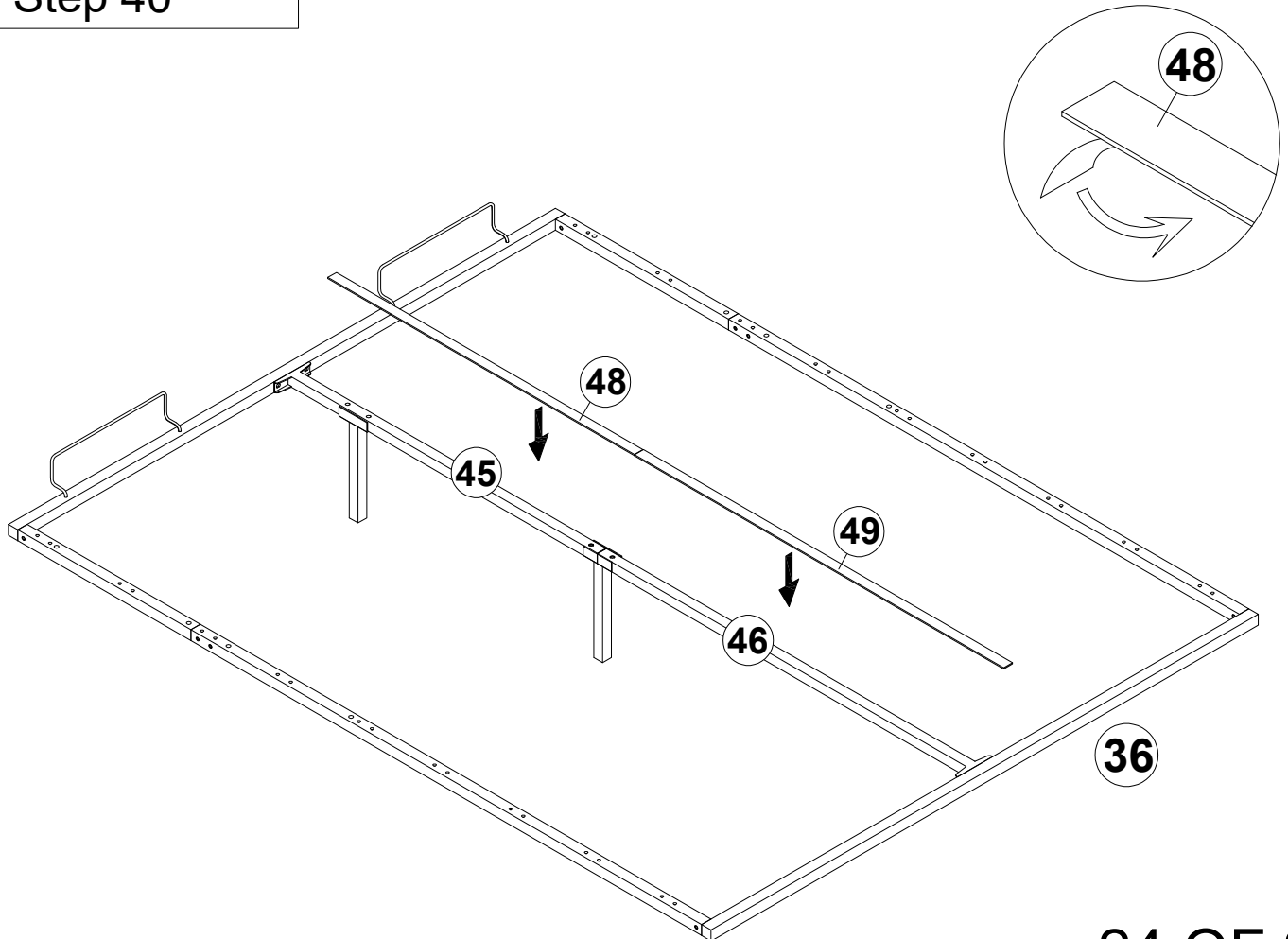

Step 40

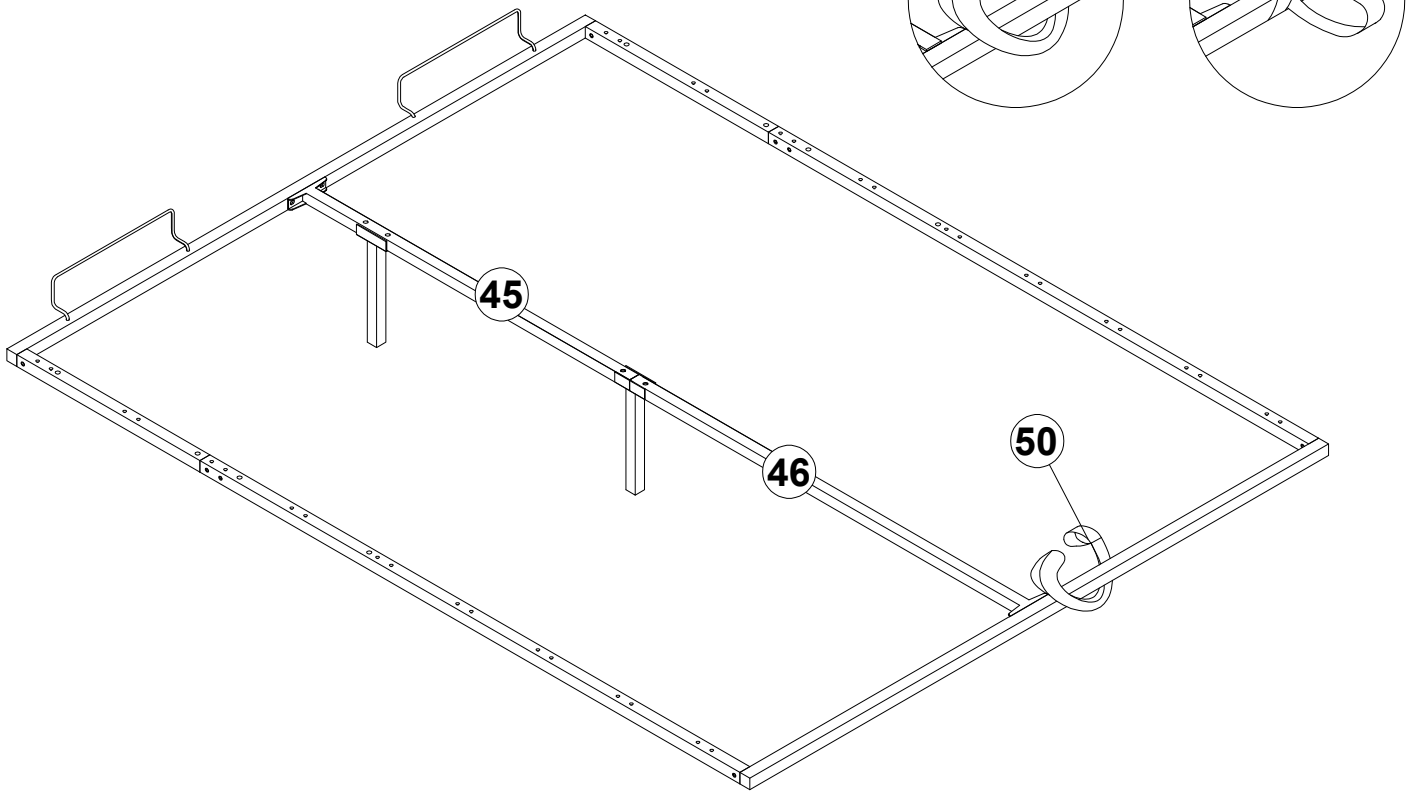

Step 41



Step 42

A		M8x45	8PCS
B			8PCS
R		M4	1PC
O			1PC

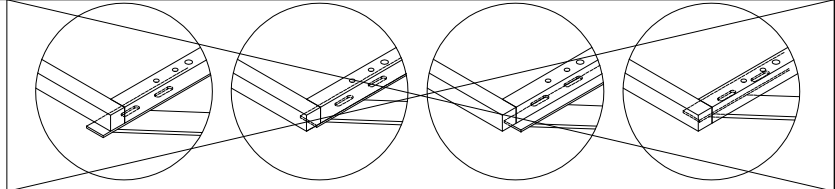
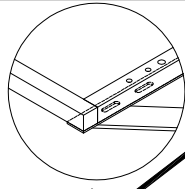

The bracket must be aligned with the metal part.

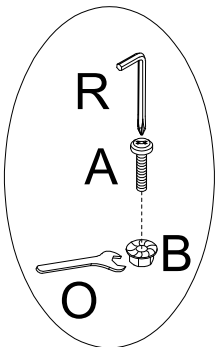
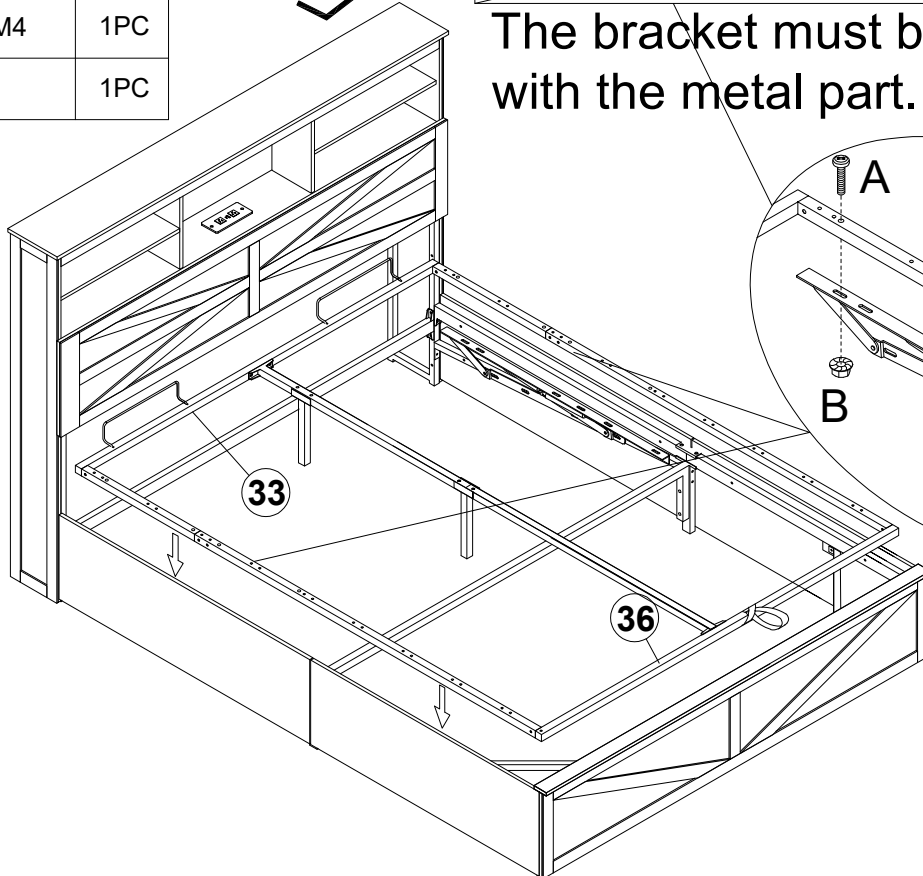

Step 43

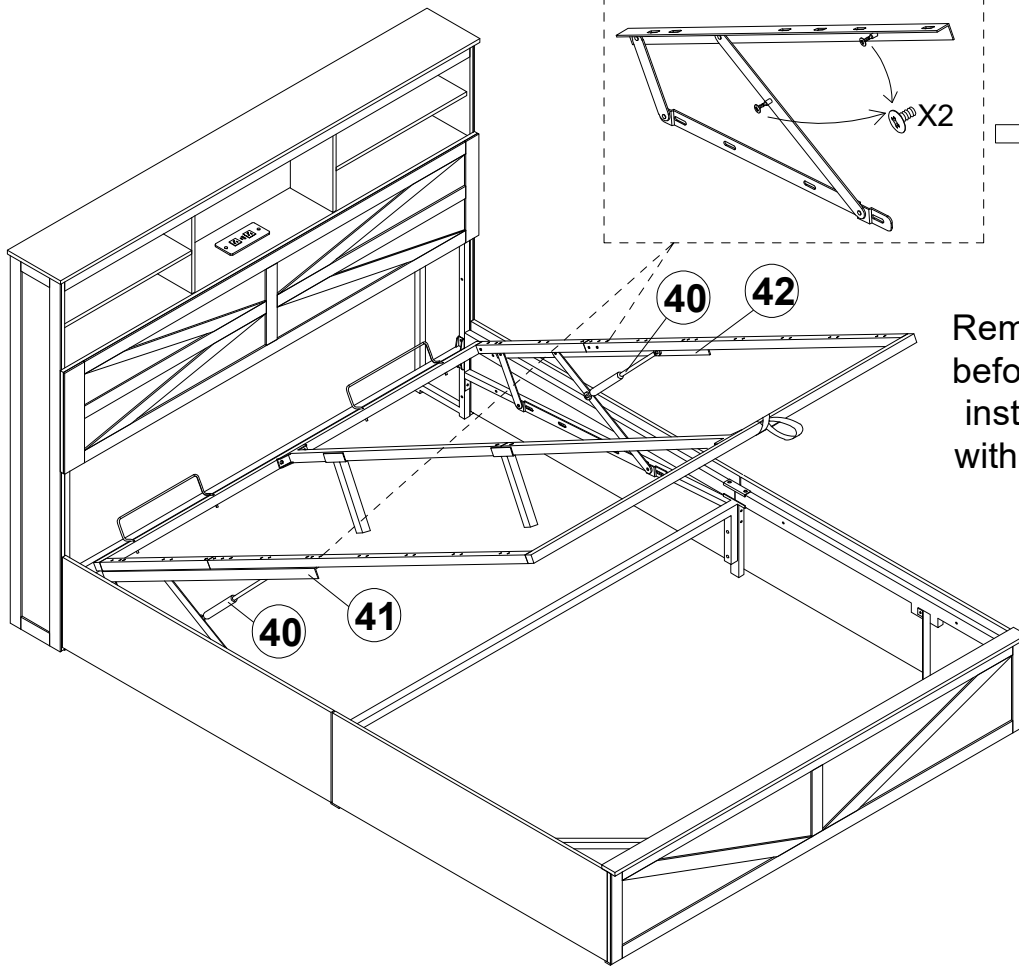

Remove screws from 39 & 40 before installation, and then install screws on 38 connecting with 39 and 40.

Step 44

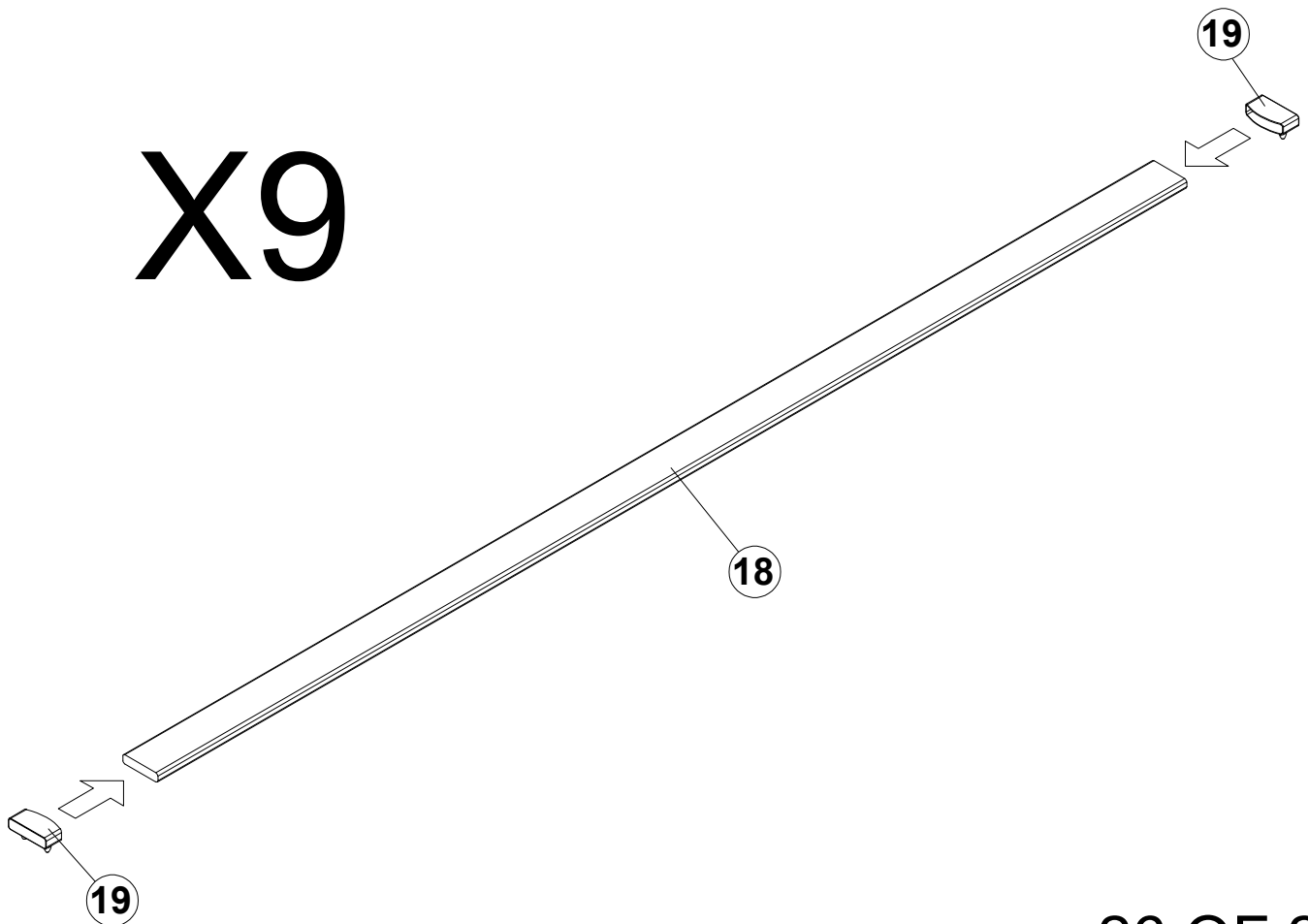

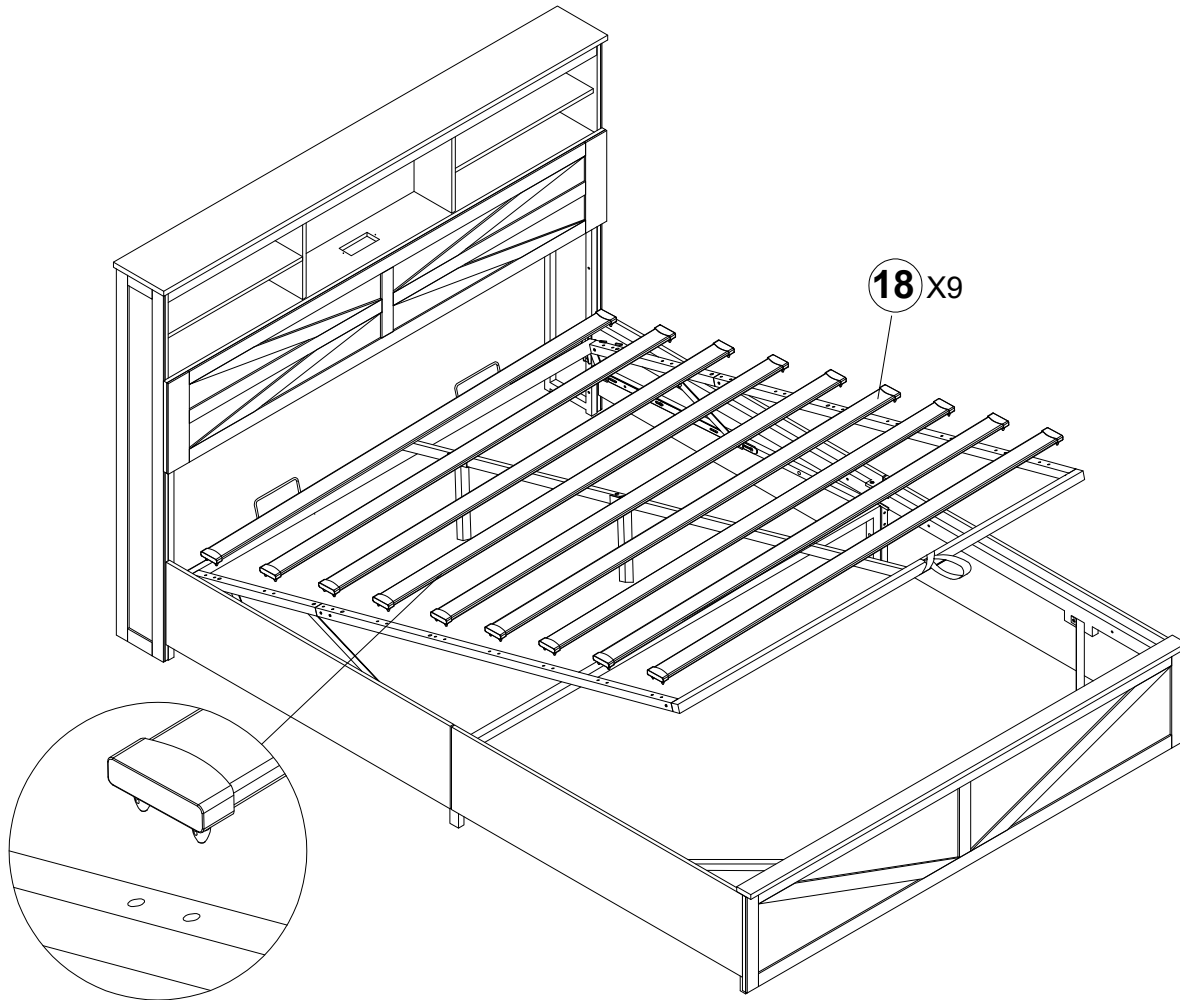

Step 45

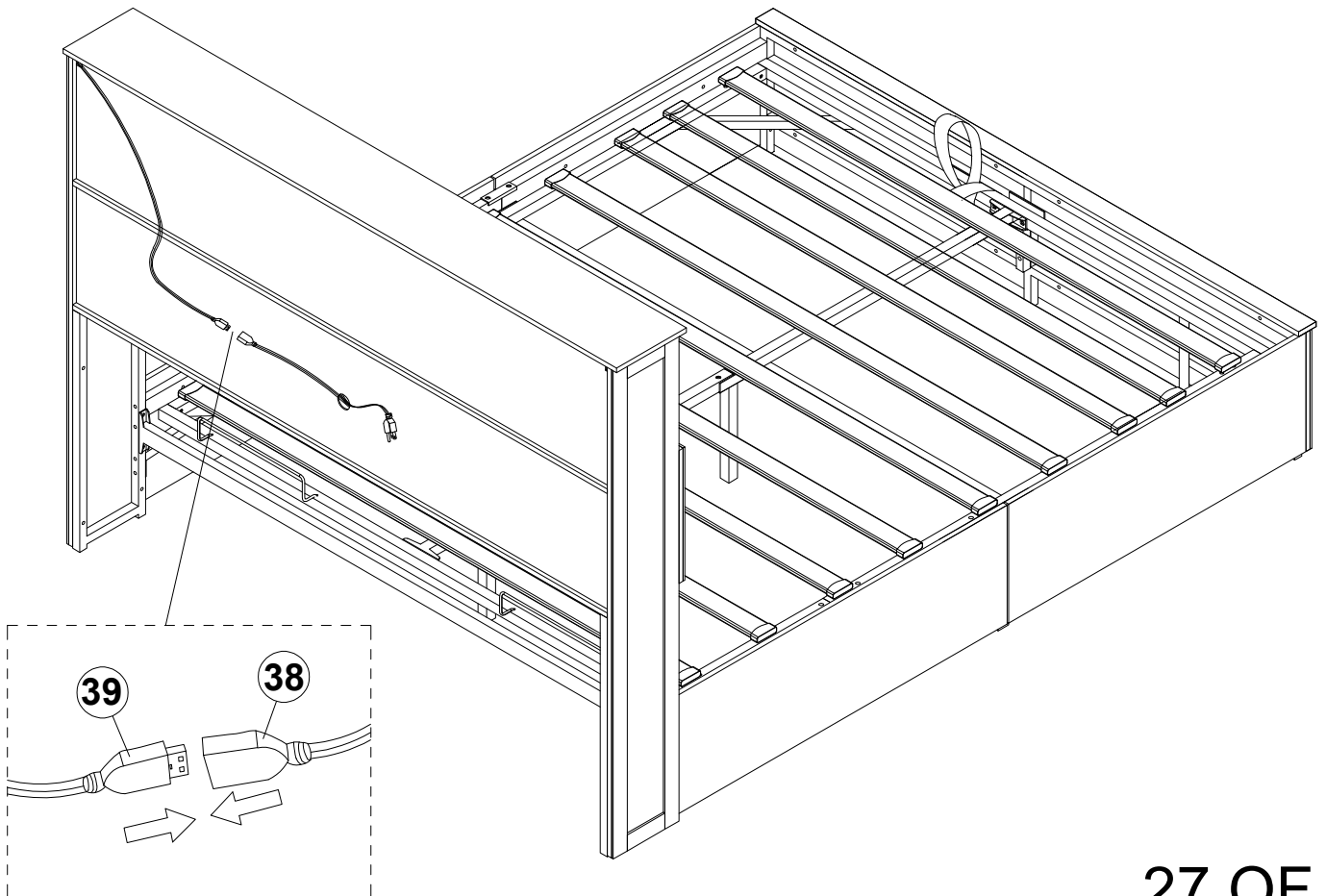

Step 46



Step 47

L		M3.5X12	12PCS
M			12PCS
R		M4	1PC

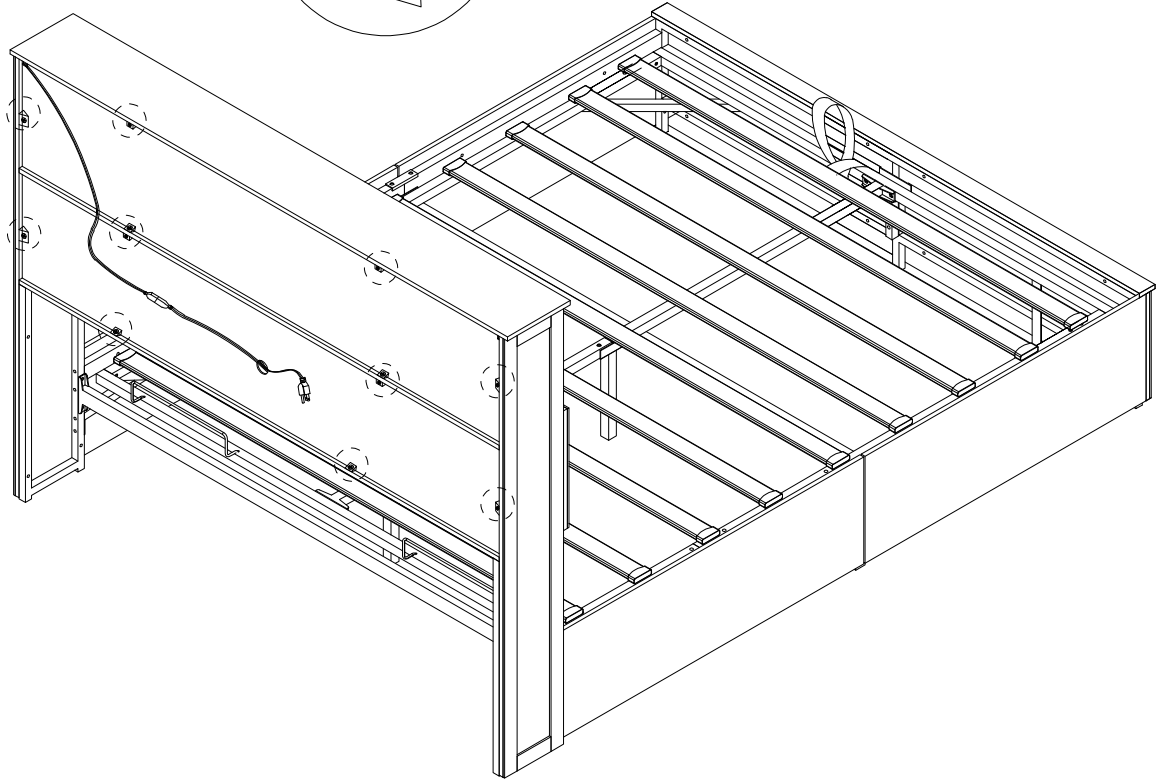
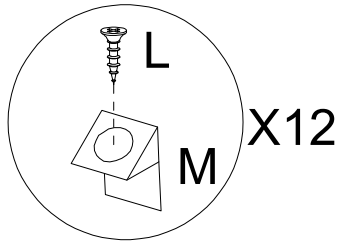

Step 48

P			4PCS
---	---	--	------

