

THIS INSTRUCTION BOOKLET CONTAINS **IMPORTANT** SAFETY INFORMATION. PLEASE READ AND KEEP FOR FUTURE REFERENCE.

ESTE FOLLETO DE INSTRUCCION CONTIENE INFORMACION **IMPORTANTE** DE SEGURIDAD. POR FAVOR LEA Y GUARDE PARA REFERENCIA FUTURA.

CE LIVRET D'INSTRUCTIONS CONTIENT DES INFORMATIONS **IMPORTANTES** SUR LA SÉCURITÉ. S.V.P. LIRE ET CONSERVER POUR RÉFÉRENCE FUTURE.



**DO NOT RETURN PRODUCT TO THE STORE**  
Individual stores do not stock parts.

**NO DEVUELVA ESTE PRODUCTO A LA TIENDA**  
Las tiendas no almacenan partes.

**NE PAS RETOURNER LE PRODUIT AU MAGASIN.**  
Les magasins individuels ne tiennent pas les pièces en inventaire.

Lot Number / Número de Lote / Numéro de lot: \_\_\_\_\_

Date Of Purchase / Fecha de Compra / Date d'achat: \_\_\_\_ / \_\_\_\_ / \_\_\_\_

**If a part is missing or damaged, call our toll-free customer service line. We will gladly ship your replacement parts FREE of charge.**

**Si faltan partes o piezas, o éstas están dañadas, llame gratis al teléfono de servicio al cliente. Con gusto le enviaremos las partes sin cargo alguno.**

**Si une pièce est manquante ou endommagée, appelez sans frais notre ligne du service à la clientèle. Il nous fera plaisir de vous expédier les pièces de remplacement GRATUITEMENT.**

For prompt, reliable service please have your assembly manual ready.  
Para obtener servicio rápido y confiable, por favor tenga esta manual a la mano.  
Pour obtenir un service rapide et fiable, s.v.p. ayez en main votre manuel d'assemblage.

**Recommended # of people needed for assembly: 2**

**El número recomendado de personas necesarias para el montaje: 2**

**# de personnes recommandées pour l'assemblage: 2**

## Before starting - Antes de empezar - Avant de débiter .

- Read each step carefully before starting. It is very important that each step of instruction is performed in the correct order. If these steps are not followed in sequence, assembly difficulties will occur.  
Leer con cuidado cada paso antes de empezar. Es muy importante de ejecutar cada paso en el orden correcto. Si los pasos no están ejecutados en secuencia, ocurrirá dificultades en el montaje.  
Lisez attentivement chaque étape avant de commencer. Il est très important que chaque étape d'instruction soit effectuée dans l'ordre indiqué. Si ces étapes ne sont pas suivies dans l'ordre, des difficultés d'assemblage se produiront.
- Make sure all parts are included. Most board parts are labeled or stamped on the raw edge.  
Asegurar que todas las piezas son incluidas. La mayoría de las tablas tienen las etiquetas o los sellos en el lado sin acabado.  
Assurez-vous que toutes les pièces sont incluses. La plupart des panneaux sont étiquetés ou estampés sur le bord non fini.
- Work in spacious area, preferably on a carpet, near the place the unit will be used.  
Trabajar en una área espaciosa, preferible sobre alfombra, cercas del lugar donde se va a usar el mueble.  
Travaillez dans un endroit spacieux, préférentiellement sur un tapis, à proximité de l'endroit où le meuble sera utilisé.
- Have the following tools close at hand.  
Tener las herramientas siguientes cerca de la mano.  
Ayez à portée de la main, les outils suivants.
- Do not use power tools to assemble your furniture. Power tools may strip or damage the parts.  
No use herramienta eléctrica para montar su unidad. Las herramientas eléctricas pueden dañar las piezas.  
Ne pas utiliser d'outils électriques pour assembler votre mobilier. Les outils électriques peuvent briser ou endommager les pièces.

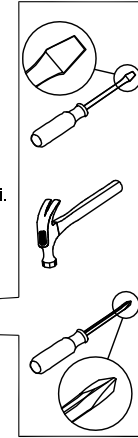

## HELPFUL HINTS

- Visit our website for assembly video clips.
- Identify, sort and count the parts before attempting assembly.
- Call our toll free number if you need assistance identifying parts.
- Compression dowels are tapped in with a hammer.
- Slides have lips only on the right side.
- Cam locks that are properly fastened on a horizontal board will face toward the center of the unit, on a vertical board the point on the lock will face the bottom.
- Back panels provide stability and support. Use all the nails provided.
- When tapping nails into a board, be sure there are equal margins on all sides to square the unit.
- Units without the back panel installed may collapse.
- Clean the product with your favorite furniture polish and a soft cloth. DO NOT USE harsh chemicals or abrasive cleaners.
- Move your new furniture carefully, with two people lift and carry the unit to it's new location.
- Never push, drag or scoot your furniture (especially on carpet).
- Your furniture can be disassembled and reassembled to move.
- Additional parts are available for a nominal fee.

## NOTES UTILES

- Visitar nuestro website para mirar los videos cortos del montaje.
- Identificar, clasificar y contar las piezas antes de intentar el montaje.
- Llamar gratis a nuestro número de servicio si necesite ayuda con identificar las piezas.
- Las clavijas de compresión se taladran con un martillo.
- Las correderas sólo tienen las protrusiones en el lado derecho.
- Las cerraduras de leva que se atan propiamente en una tabla horizontal se puntan al centro de la unidad, y las en una tabla vertical se puntan al fondo.
- Los paneles traseros se mantienen la estabilidad. Usar todos los tornillos proporcionados.
- A taladrar los tornillos en una tabla, asegurarse que hay márgenes iguales en todos los lados para cuadrar la unidad.
- Las unidades sin panel trasero pueden derrumbarse.
- Limpiar la unidad con su pulimento favorito de mueble y una tela suave. NO UTILIZAR productos con químicos duros o abrasivos.
- Mover su mueble nuevo cuidadosamente, con dos personas levantar la unidad a su nuevo lugar.
- Nunca empujar o arrastrar su mueble (especialmente en alfombra).
- Poderse desmontar y volver a montar su mueble de para mover.
- Piezas adicionales están disponibles para una cuota nominal.

## CONSEILS UTILES

- Visitez notre site Web pour visionner des vidéos d'assemblage.
- Identifiez, trie et compter les pièces avant d'entreprendre l'assemblage.
- Appelez notre numéro sans frais si vous avez besoin d'aide pour identifier les pièces.
- Les goujons de compression sont enfoncés en frappant avec un marteau.
- Les glissières ont un rebord sur le côté droit seulement.
- Les serrures de came qui sont fixées correctement sur un panneau horizontal seront orientées vers le centre du meuble, sur un panneau vertical, la pointe de la serrure sera orientée vers le bas.
- Les panneaux arrière assurent la stabilité et le soutien. Utilisez tous les clous fournis.
- Lorsque vous frappez les clous dans le panneau, assurez-vous qu'ils sont à distance égale sur tous les côtés pour bien cadrer le meuble.
- Les meubles sans panneau arrière installé peuvent s'effondrer.
- Nettoyez le meuble avant votre poli à meubles préféré et un chiffon doux. NE PAS UTILISER de produits chimiques forts ou de nettoyants abrasifs.
- Déplacez délicatement votre nouveau meuble, avec deux personnes pour soulever et transporter le meuble à son nouvel emplacement.
- Ne jamais pousser, traîner ou tirer votre meuble (surtout sur un tapis).
- Votre meuble peut être démonté et réassemblé pour le déplacer.
- Des pièces supplémentaires sont disponibles pour un prix modique.

**PARTS -PIEZAS - PIÈCES**

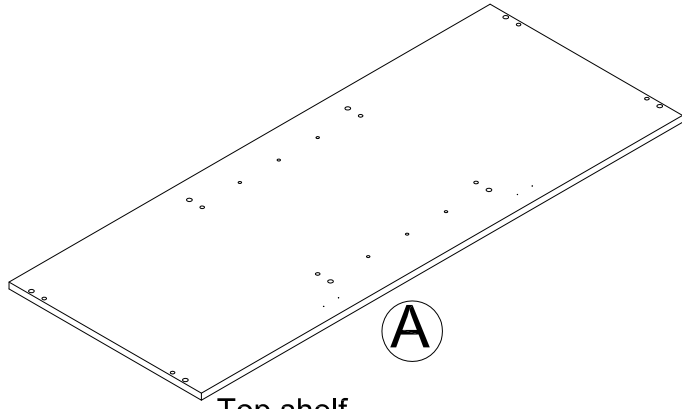

**A**  
 Top shelf  
 Estante superior  
 Étagère supérieure

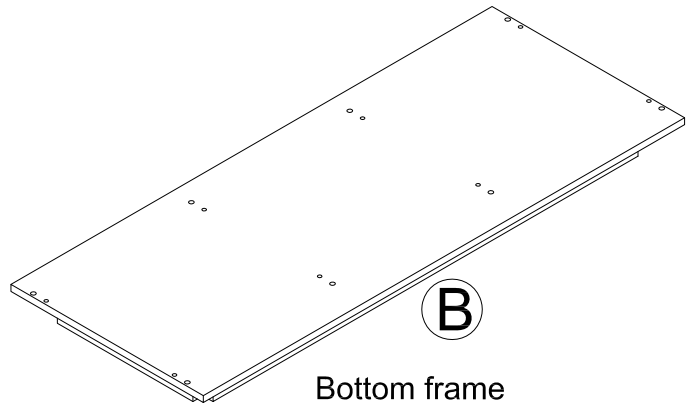

**B**  
 Bottom frame  
 Marco inferior  
 Cadre inférieur

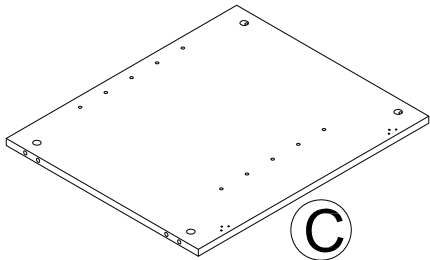

**C**  
 Side frame (2)  
 Marco Izquierdo (2)  
 Cadre gauche (2)

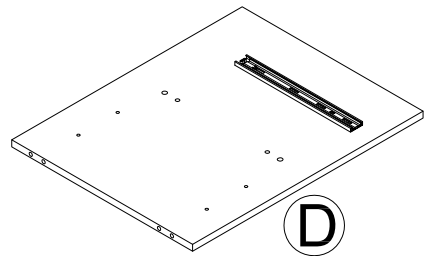

**D**  
 Left partition  
 Partición izquierda  
 Cloison gauche

Preassembled parts / Partes premontadas / Pièces réassemblées			
Left partition/Partición izquierda/Cloison gauche			
14" slide member / Nivelador 14" / Élément coulissant 35.5 cm (14") (1)	TSF3007		
Screw / Tornillo / Vis Ø3.5x12 (3)	TSF0601		

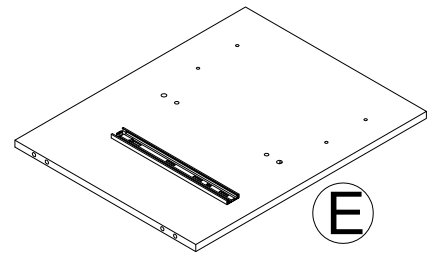

**E**  
 Right partition  
 Partición derecha  
 Cloison droite

Preassembled parts / Partes premontadas / Pièces réassemblées			
Right partition/Partición derecha/Cloison droite			
14" slide member / Nivelador 14" / Élément coulissant 35.5 cm (14") (1)	TSF3007		
Screw / Tornillo / Vis Ø3.5x12 (3)	TSF0601		

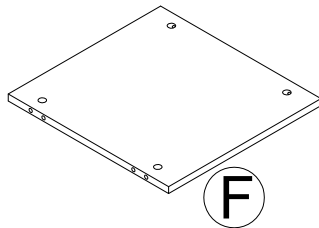

Middle fixed shelf  
Estante fijo central  
Étagère fixe centrale

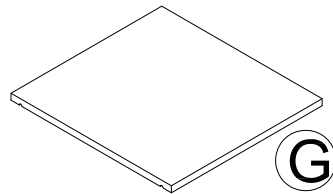

Adjustable shelf (2)  
Tablero ajustable (2)  
Tablette réglable (2)

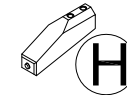

Foot (4)  
Pie (4)  
Pied (4)

Preassembled parts / Partes premontadas / Pièces réassemblées	
Foot /Pie /Pied	
Tack Glide/Tack Glide/Fixation	TSF0023

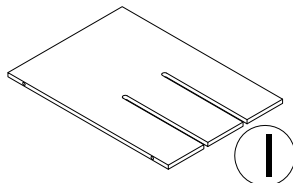

Partition (3)  
Partición (3)  
Cloison (3)

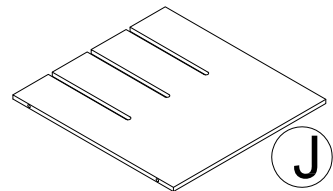

Middle fixed shelf (2)  
Repisa fija central (2)  
Étagère médiane fixe (2)

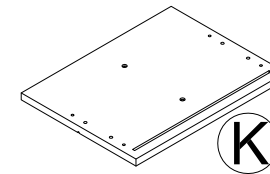

Drawer front  
 tiroir devant  
Frente de cajon

**PARTS -PIEZAS - PIÈCES**

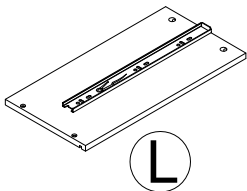

**Left drawer side**  
 le tiroir de gauche côté  
 El lado izquierdo

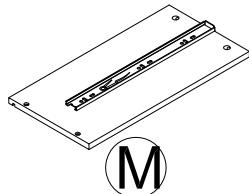

**Right drawer side**  
 tiroir de droite côté  
 Cajón derecho lado

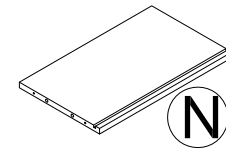

**Drawer back**  
 tiroir arrière  
 Cajón de vuelta

Preassembled parts / Partes premontadas / Pièces réassemblées	
Left drawer side	
14" slide runner / Guía 14"/ Élément coulissant 35.5 cm (14")	TSF3008
Screw / Tornillo / Vis Ø3.5x12 (3)	TSF0601

Preassembled parts / Partes premontadas / Pièces réassemblées	
Right drawer side	
14" slide runner / Guía 14"/ Élément coulissant 35.5 cm (14")	TSF3008
Screw / Tornillo / Vis Ø3.5x12 (3)	TSF0601

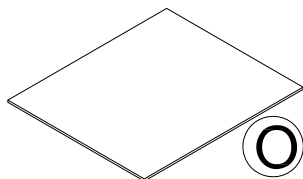

**Drawer bottom**  
 tiroir du bas  
 Cajón de abajo

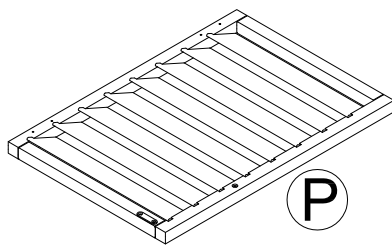

**Left door**  
 Puerta izquierda  
 Porte gauche

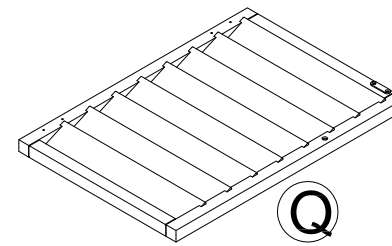

**Right door**  
 Puerta derecha  
 Porte droite

Preassembled parts / Partes premontadas / Pièces réassemblées	
Left door/Puerta izquierda/Porte gauche	
Washer/Arandela/Rondelle	TSF2402
Screw / Tornillo / Vis Ø3.5x12 (2)	TSF0601

Preassembled parts / Partes premontadas / Pièces réassemblées	
Right door/Puerta derecha /Porte droite	
Washer/Arandela/Rondelle	TSF2402
Screw / Tornillo / Vis Ø3.5x12 (2)	TSF0601

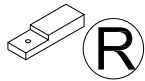

Foot  
Pie  
Pied

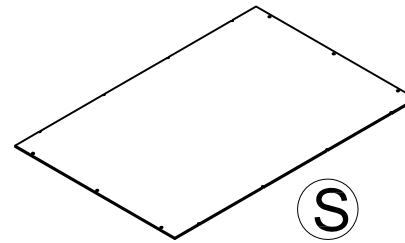

Center back panel  
Panel trasero central  
Panneau arrière central

Preassembled parts / Partes premontadas / Pièces réassemblées	
Foot /Pie /Pied	
Adjustable End Cap/Tapa Ajustable embellecedora/Patin réglable	TSF0024

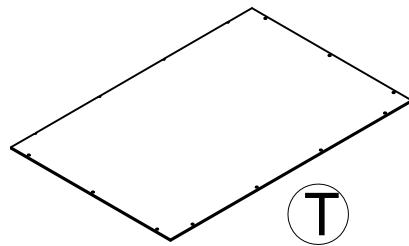

Back panel (2)  
Panel trasero (2)  
Panneau arrière (2)

PARTS -PIEZAS - PIÈCES

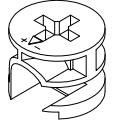

Ø15X12mm

① x 20

Cam lock  
Tornillo de cerradura  
Serrure de came  
TSF0303



Ø8X35mm

② x 20

Cam bolt  
Tornillo de rosca  
Boulon de camde  
TSF0351

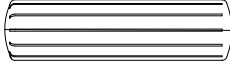

Ø8X30mm

③ x 20

Wood dowel  
Clavija de madera  
Goujon en bois  
TSF0501

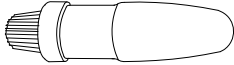

④ x 1

Glue  
Pegamento  
Colle  
TSF0015

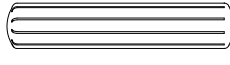

Ø6X30mm

⑤ x 28

Wood dowel  
Clavija de madera  
Goujon en bois  
TSF0003

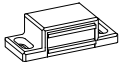

⑥ x 2

Magic catch  
Pestillo mágico  
Loquet magique  
TSF0016

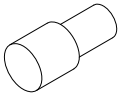

Ø7X15mm

⑦ x 8

Shelf support  
Soporte de repisa  
Support de tablette  
TSF0008



Ø7 X10mm

⑧ x 9

Spring washer  
Arandela de resorte  
Rondelle à ressort  
TSF2451



Ø7X16mm

⑨ x9

Washer  
Arandela  
Rondelle  
TSF2452

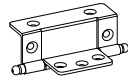

95X38X27XT2.0

⑩ x 4

Hinge  
Bisagra  
Charnière  
TSF2701

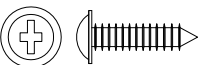

Ø3.5X14mm

⑪ x 34

Screw  
Tornillo  
Vis  
TSF1003

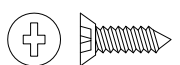

Ø3.5X12mm

⑫ x 28

Screw  
Tornillo  
Vis  
TSF0601

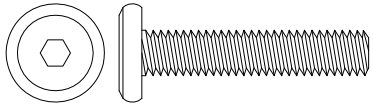

Ø1/4X30mm

⑬ x 1

Bolt  
Tornillo  
Boulon  
TSF1403

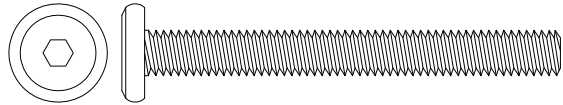

Ø1/4X55mm

⑭ x 8

Bolt  
Tornillo  
Boulon  
TSF1401

**PARTS -PIEZAS - PIÈCES**

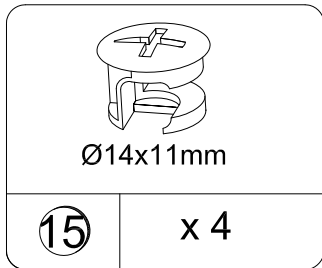

Cam lock  
Tornillo de cerradura  
Serrure de came  
TSF0305

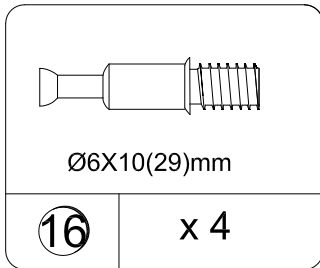

Cam bolt  
Tornillo de rosca  
Boulon de camde  
TSF0002

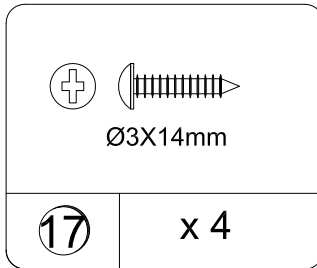

Screw  
Tornillo  
Vis  
TSF1001

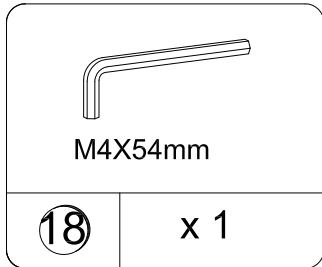

Hex key  
Llave en I  
Clé hexagonale  
TSF2801

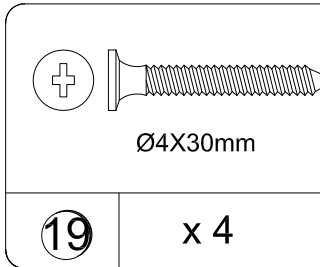

Screw  
Tornillo  
Vis  
TSF0602

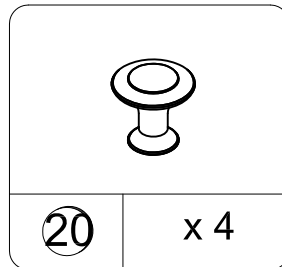

Knob  
Puno  
Bouton  
TSF2201

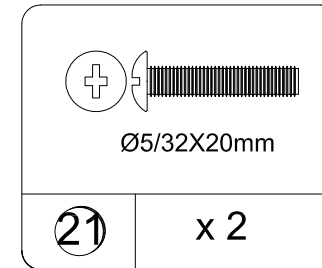

Screw bolt  
Tornillo con tuerca  
Vis à boulon  
TSF1811

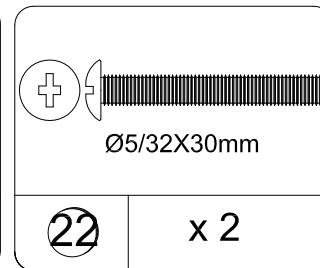

Screw bolt  
Tornillo con tuerca  
Vis à boulon  
TSF1816

This illustration shows how the CAM fastening system works.  
Esta ilustración muestra como funciona el sistema de fijación de leva.  
Cette illustration montre comment le système de fixation de la CAME fonctionne

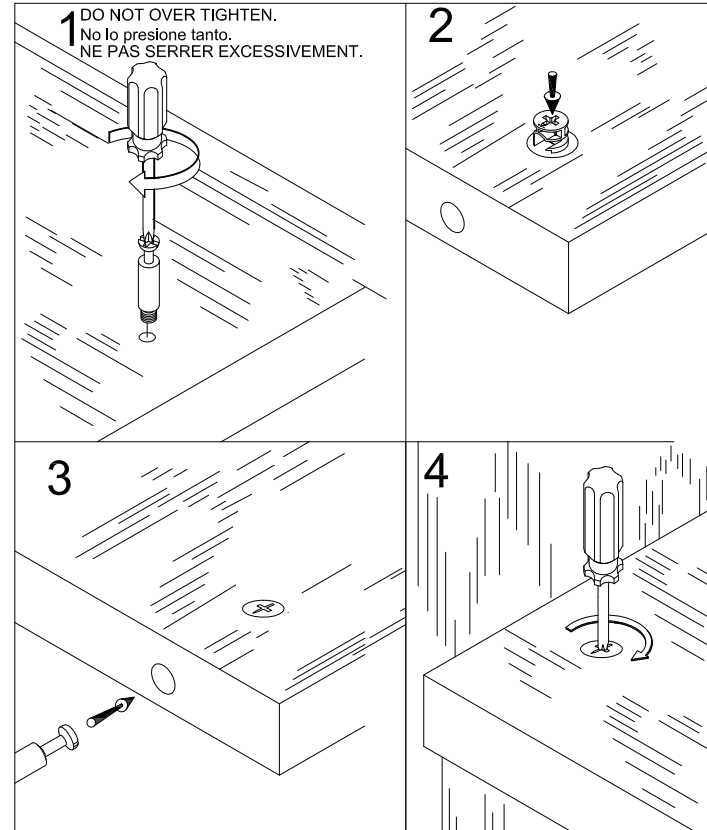

# 1

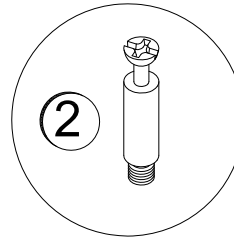
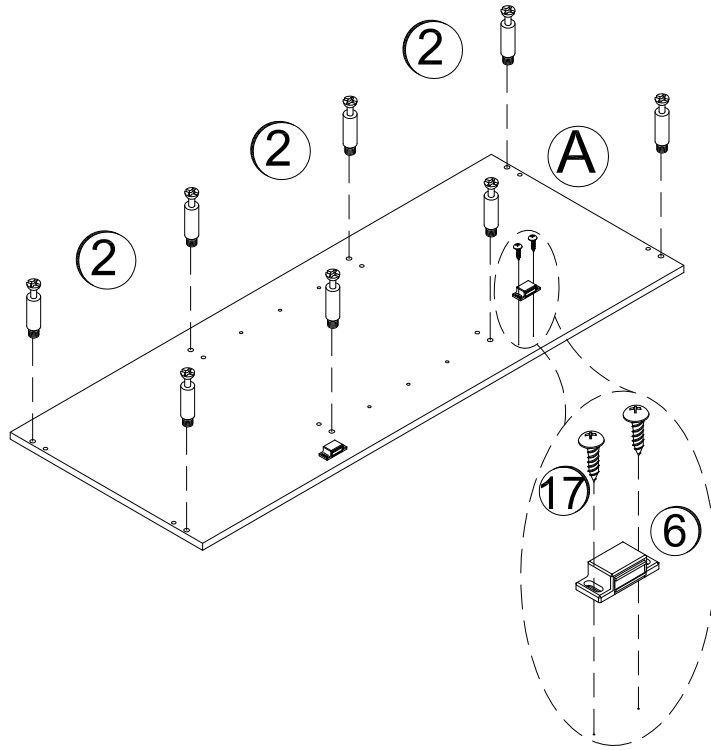

Do not over tighten.  
No lo presione tanto.  
Ne pas serrer excessivement.

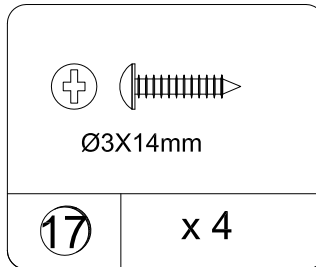
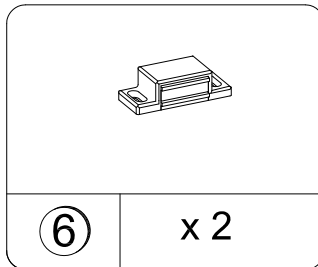
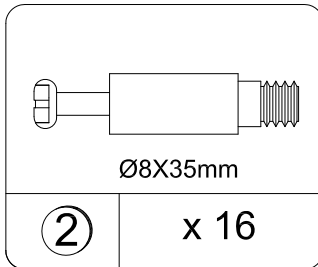
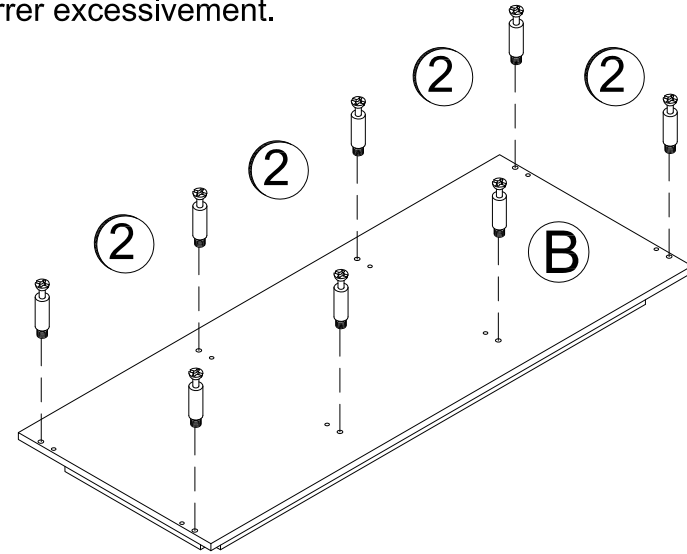

# 2

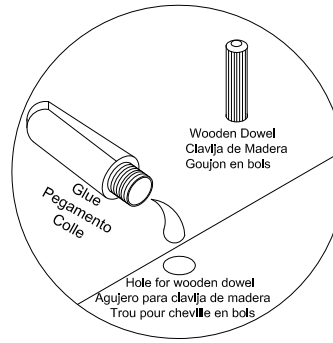
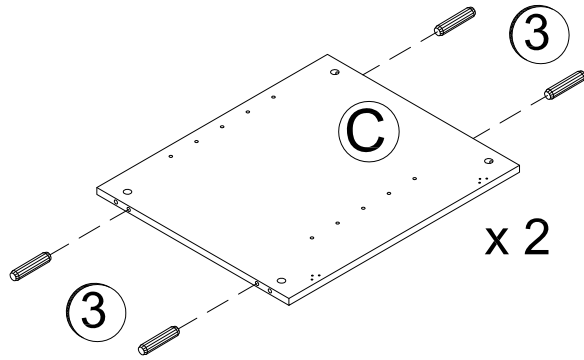

Use one drop of glue in dowel hole.  
 Use una gota de pegamento en el agujero de clavija.  
 Utilisez une goutte de colle dans le trou de la cheville

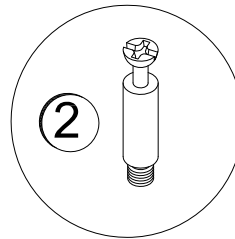
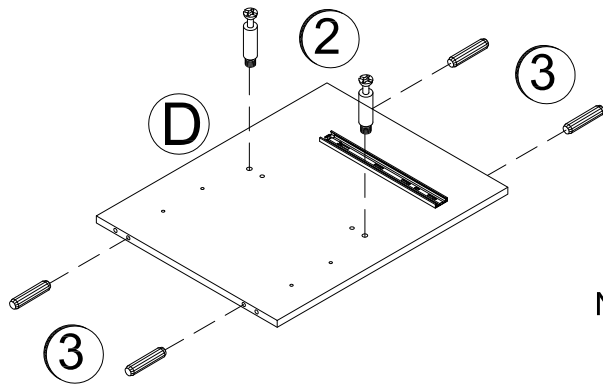

Do not over tighten.  
 No lo presione tanto.  
 Ne pas serrer excessivement.

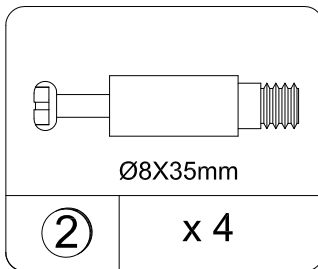
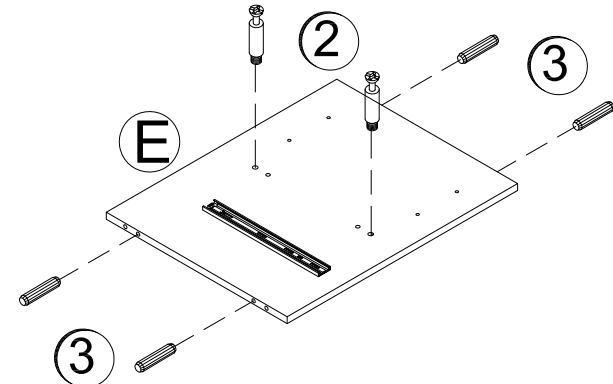

2

x 4

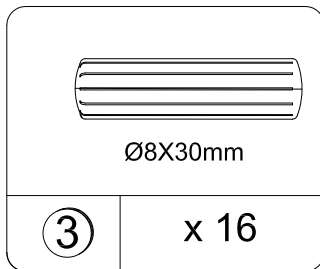

3

x 16

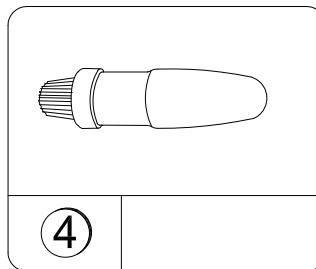

4

# 3

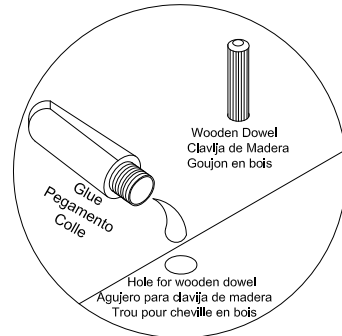
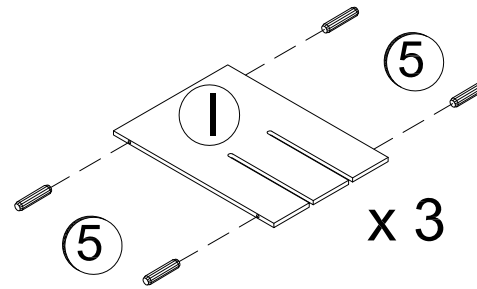
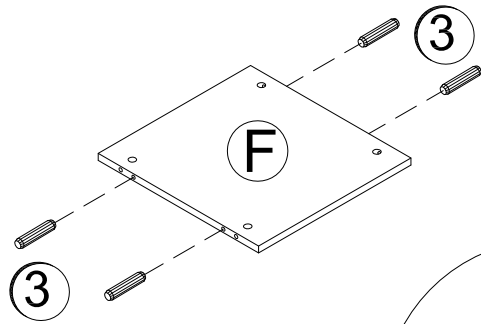

Use one drop of glue in dowel hole.  
 Use una gota de pegamento en el agujero de clavija.  
 Utilisez une goutte de colle dans le trou de la cheville

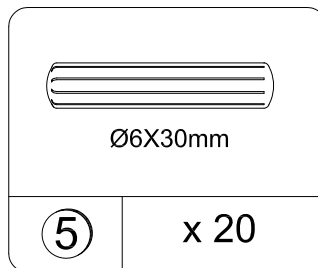
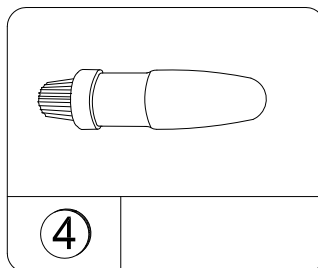
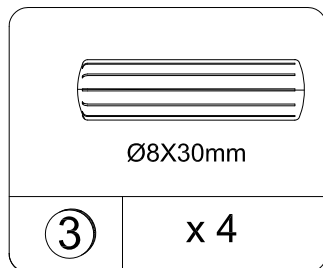
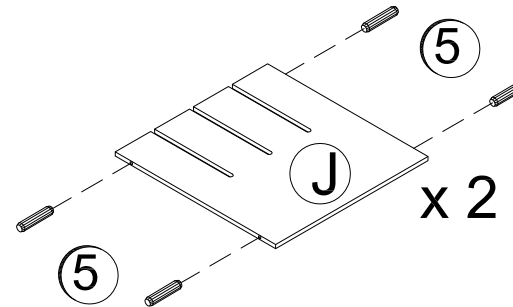

# 4

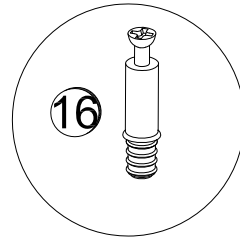
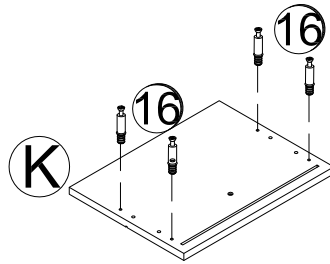

Do not over tighten.  
No lo presione tanto.  
Ne pas serrer excessivement.

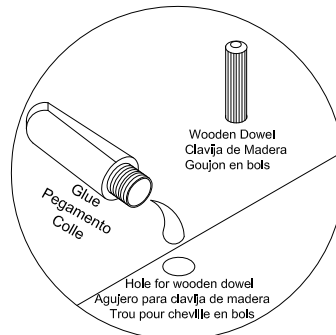
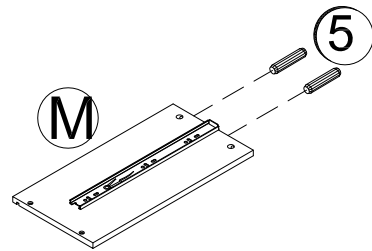
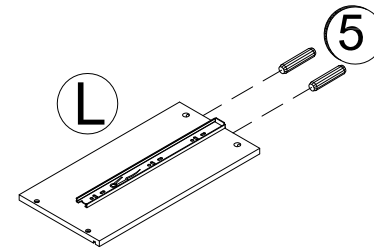

Use one drop of glue in dowel hole.  
Use una gota de pegamento en el agujero de clavija.  
Utilisez une goutte de colle dans le trou de la cheville

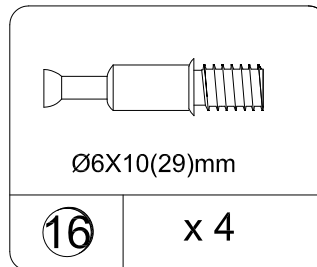
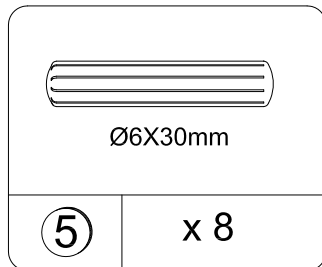
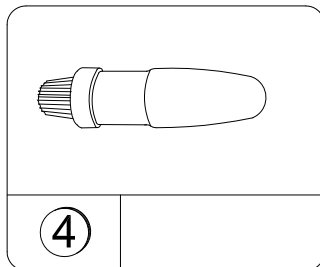
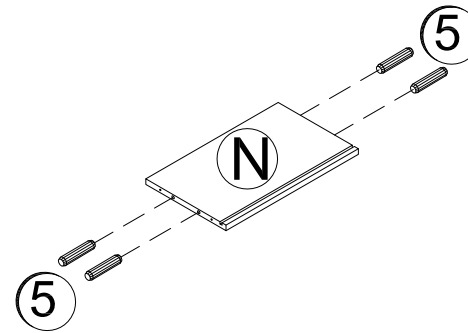

# 5

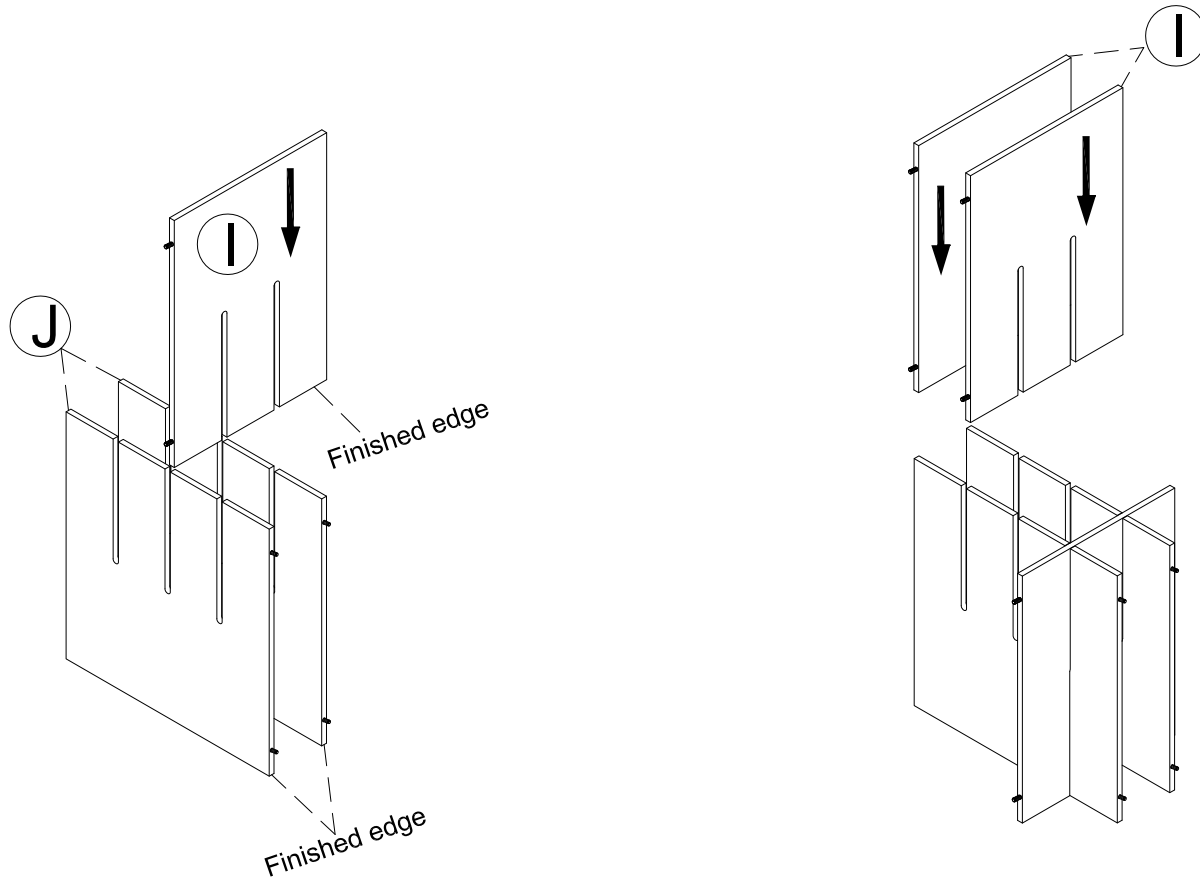

# 6

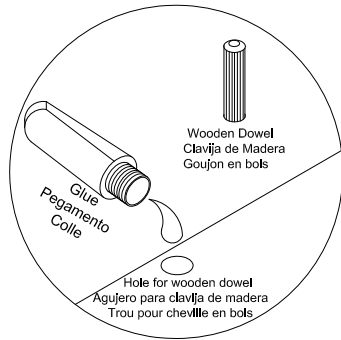

Use one drop of glue in dowel hole.  
Use una gota de pegamento en el agujero de clavija.  
Utilisez une goutte de colle dans le trou de la cheville

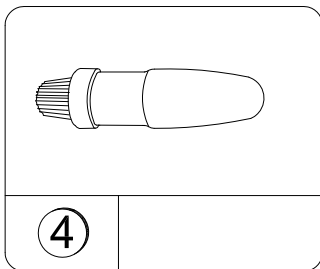
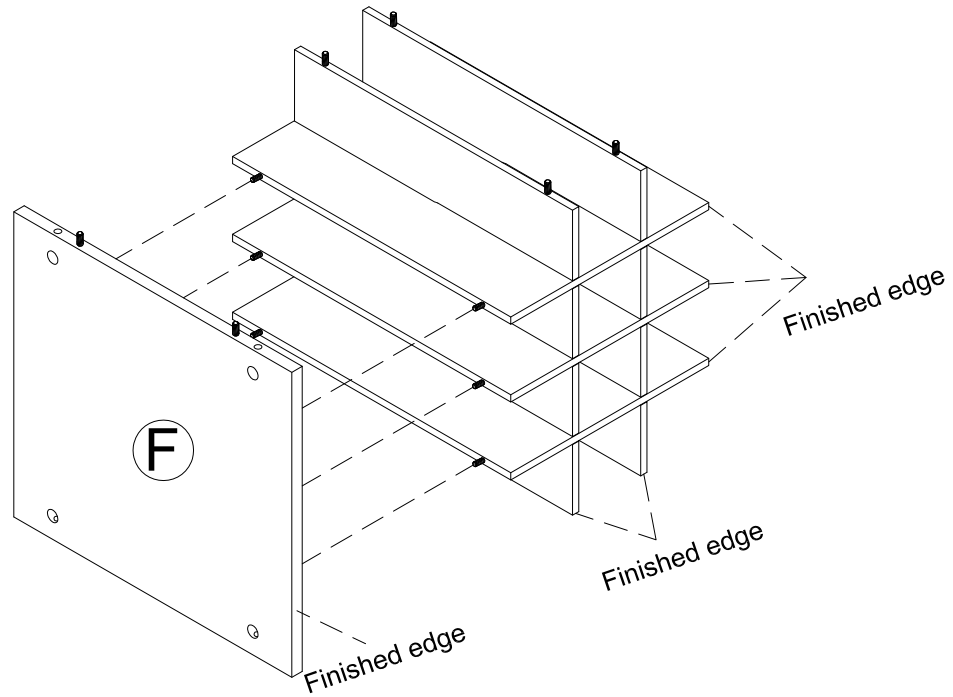

# 7

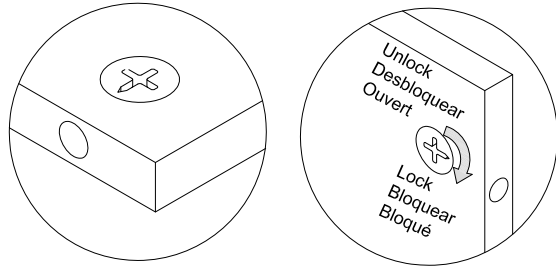

Proper orientation of cam lock  
 La orientación apropiada para el seguro de bloqueo  
 Bonne orientation du dispositif de blocage à came

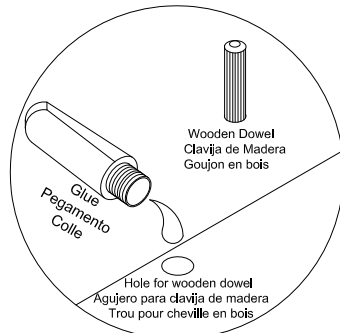

Use one drop of glue in dowel hole.  
 Use una gota de pegamento en el agujero de clavija.  
 Utilisez une goutte de colle dans le trou de la cheville

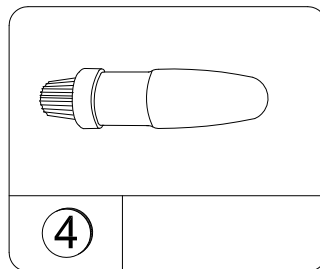
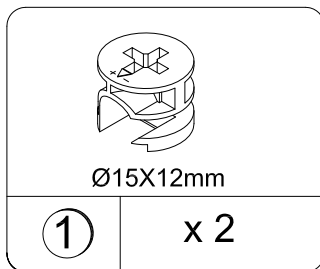
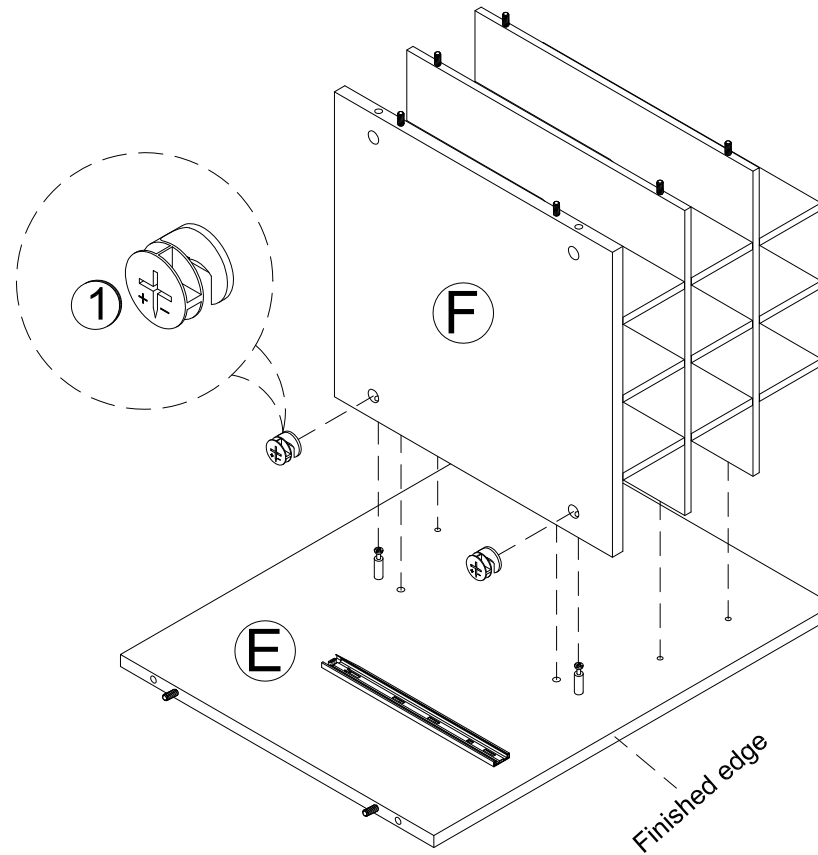

# 8

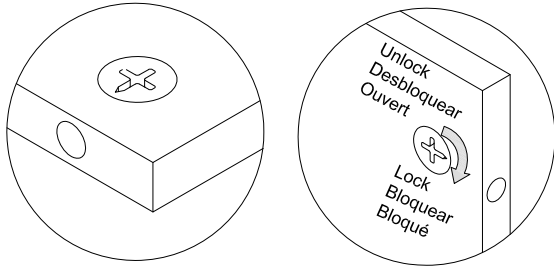

Proper orientation of cam lock  
 La orientación apropiada para el seguro de bloqueo  
 Bonne orientation du dispositif de blocage à came

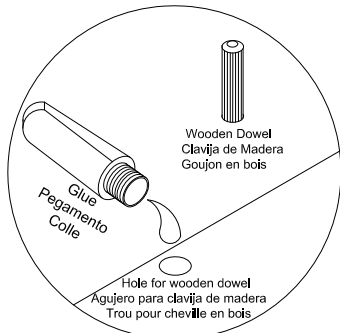

Use one drop of glue in dowel hole.  
 Use una gota de pegamento en el agujero de clavija.  
 Utilisez une goutte de colle dans le trou de la cheville

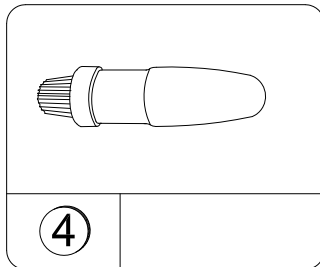
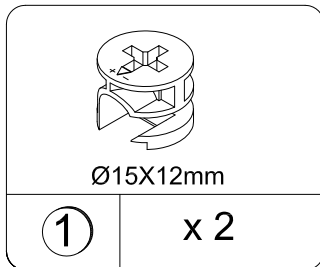

Note: Hold on until the cam lock is tightened.  
 Note: Attends jusqu'à ce que le cam lock est renforcée.  
 Note: Espere hasta que la cerradura de la leva es apretado.

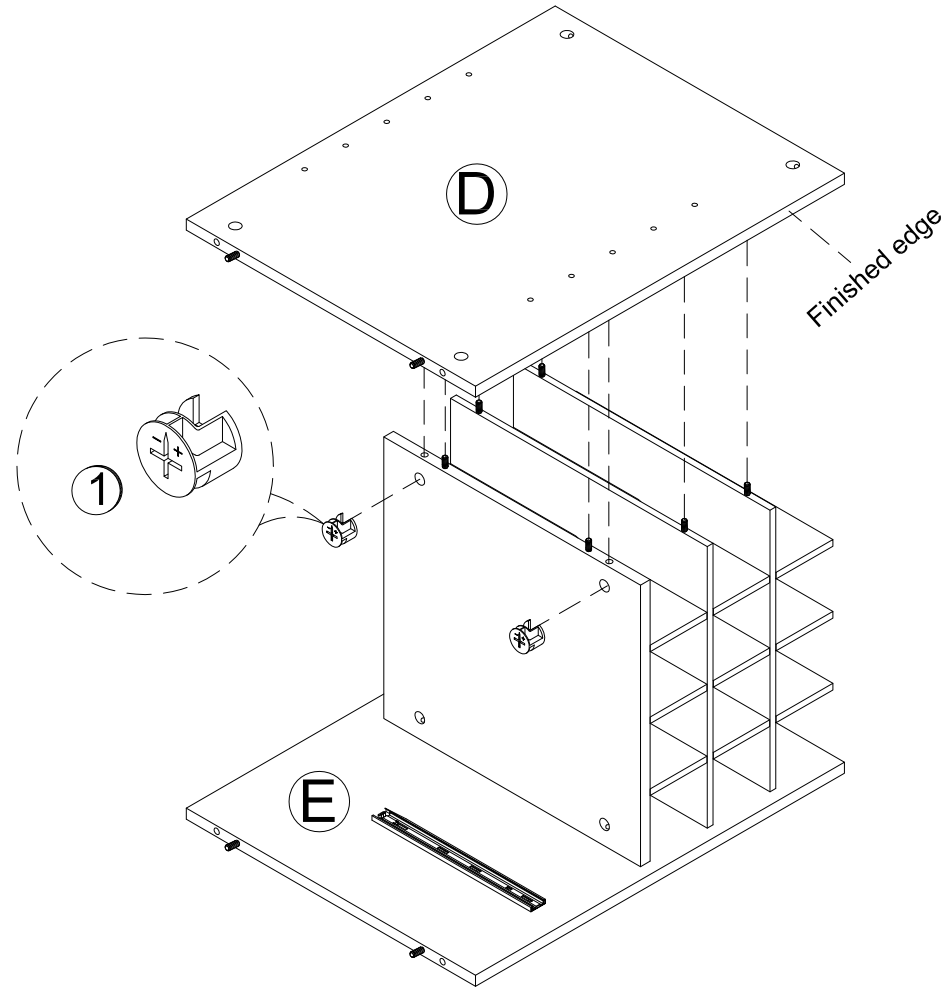

# 9

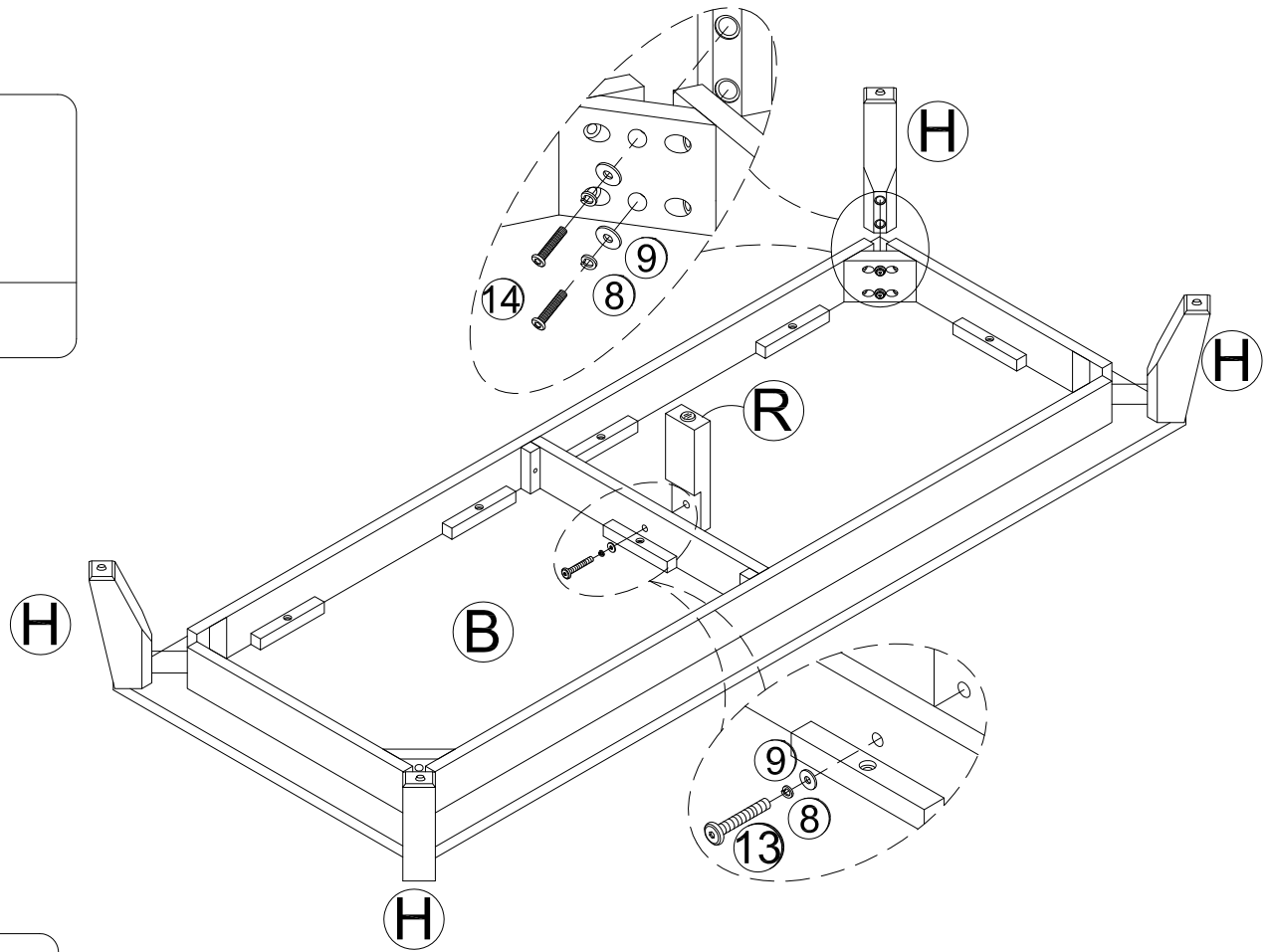
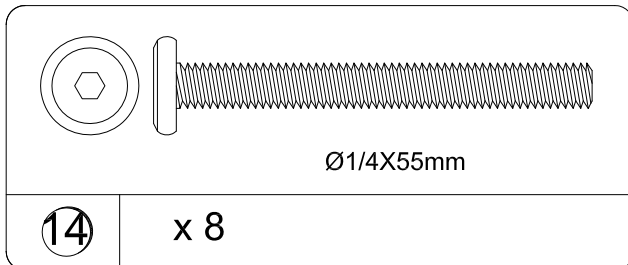
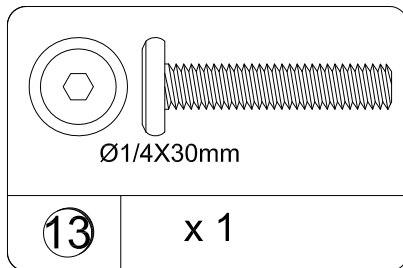
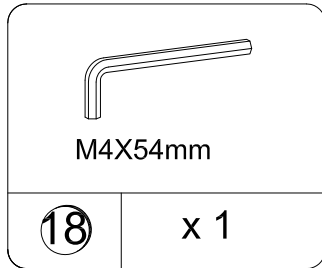
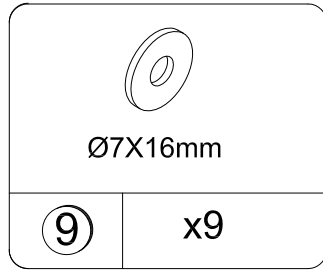
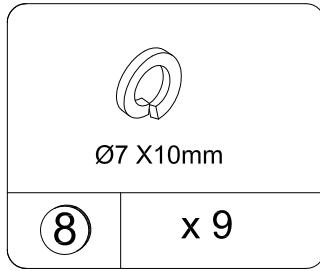

# 10

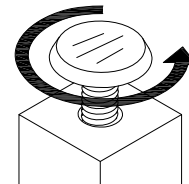
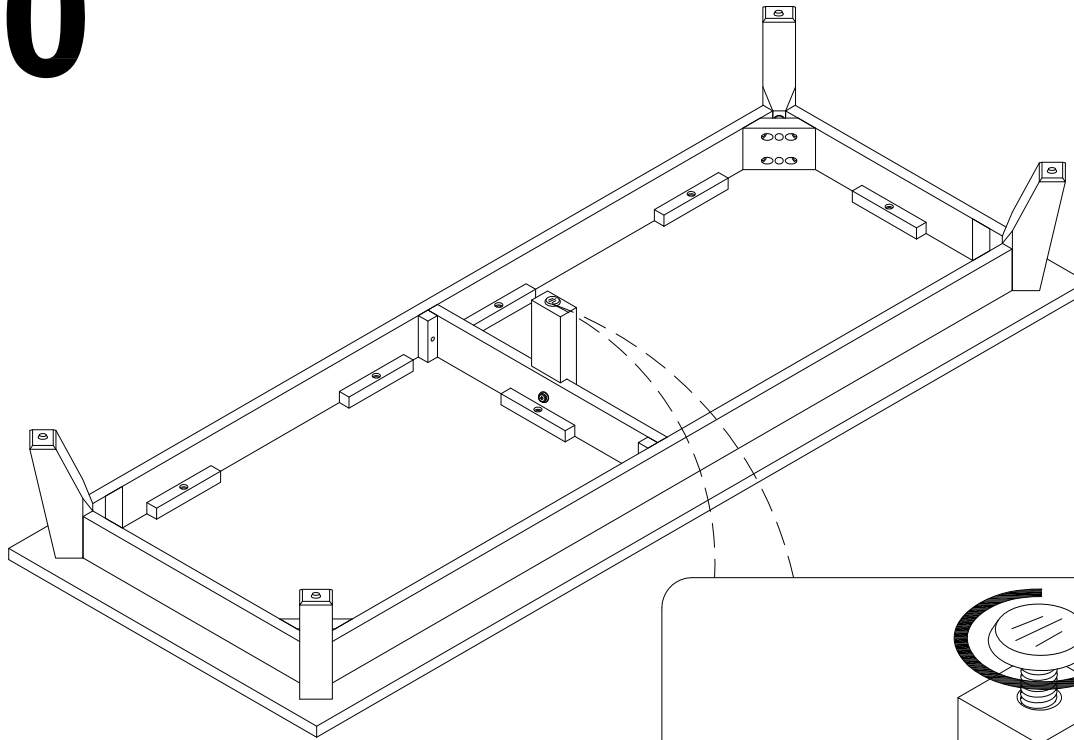

If the ground is uneven, adjust the foot levelers by rotating them to your preferred height. Once the cabinet is standing and the levelers are adjusted, make sure the unit does not wobble.

Si el suelo está disparejo, ajuste los niveladores de pata girándolos a la altura requerida. Cuando el escritorio está de pie y los niveladores están ajustados, asegúrese de que la unidad no se tambalee.

Si le sol est inégal, ajustez les patins réglables en les faisant tourner à la hauteur désirée. Lorsque le bureau est debout et que les patins sont ajustés, assurez-vous que l'unité ne vacille pas.

# 11

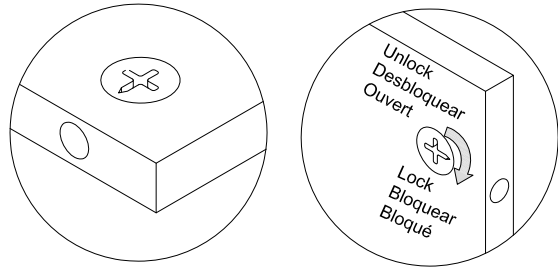

Proper orientation of cam lock  
 La orientación apropiada para el seguro de bloqueo  
 Bonne orientation du dispositif de blocage à came

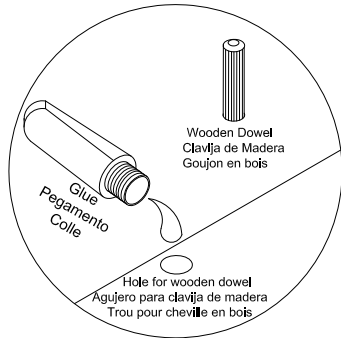

Use one drop of glue in dowel hole.  
 Use una gota de pegamento en el agujero de clavija.  
 Utilisez une goutte de colle dans le trou de la cheville

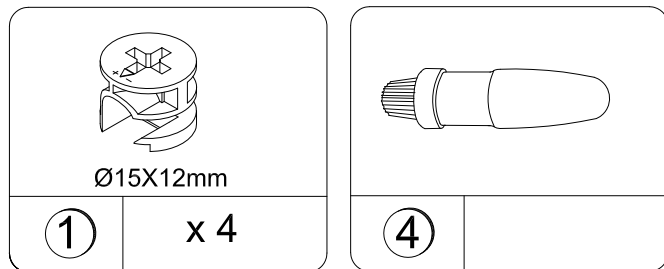

Note: Hold parts E and D together when they are picked up and moved to part B.  
 NOTA: Mantenga partes e y D juntos cuando se levantó y se mudó a la parte B.  
 note: tenir les parties e et d ensemble quand ils sont ramassés et transféré à la partie b .

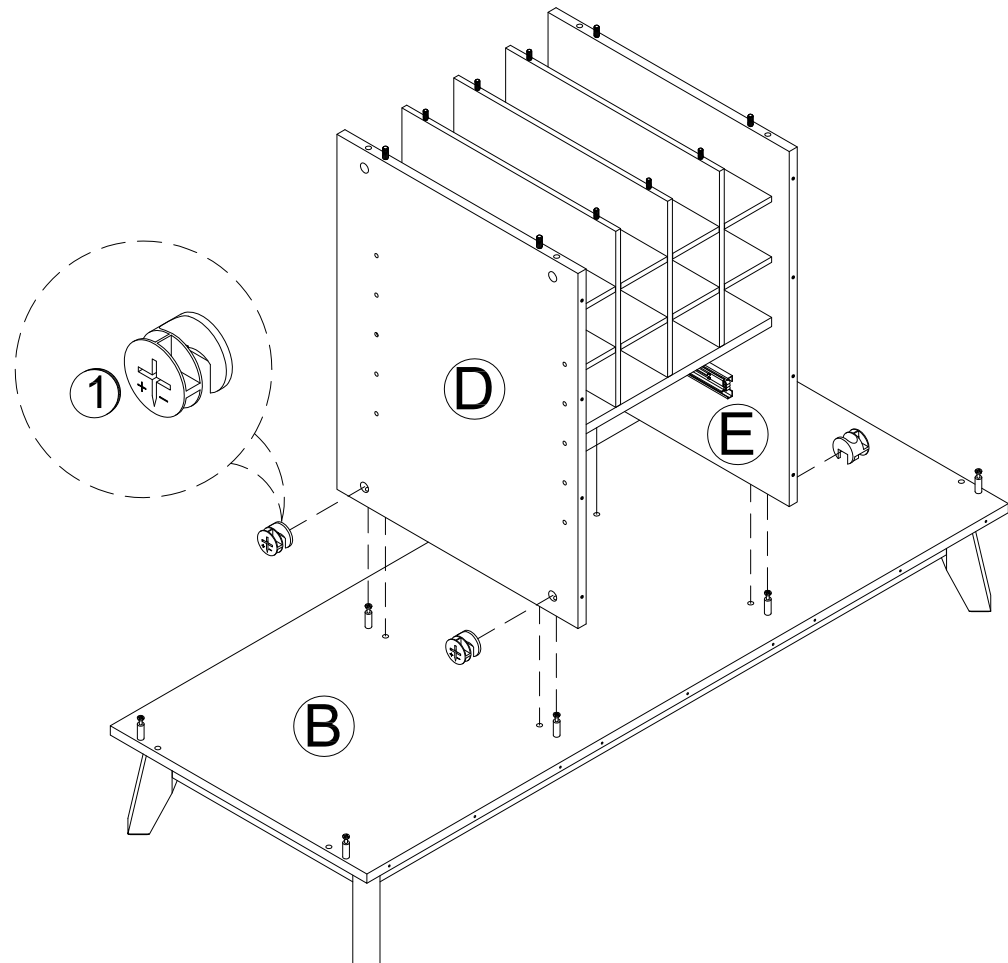

# 12

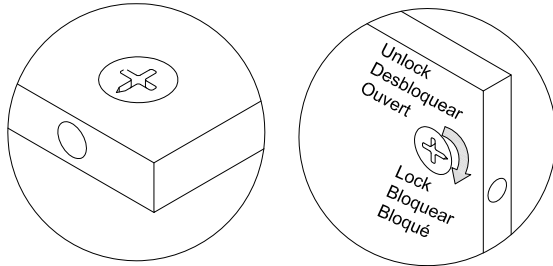

Proper orientation of cam lock  
La orientación apropiada para el seguro de bloqueo  
Bonne orientation du dispositif de blocage à came

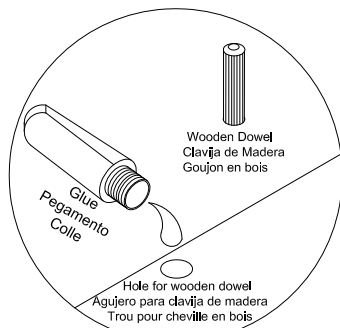

Use one drop of glue in dowel hole.  
Use una gota de pegamento en el agujero de clavija.  
Utilisez une goutte de colle dans le trou de la cheville

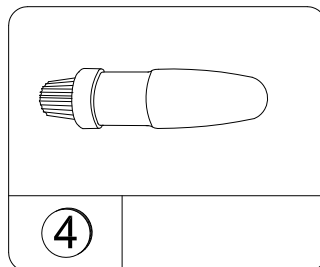
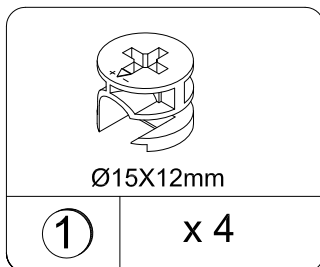
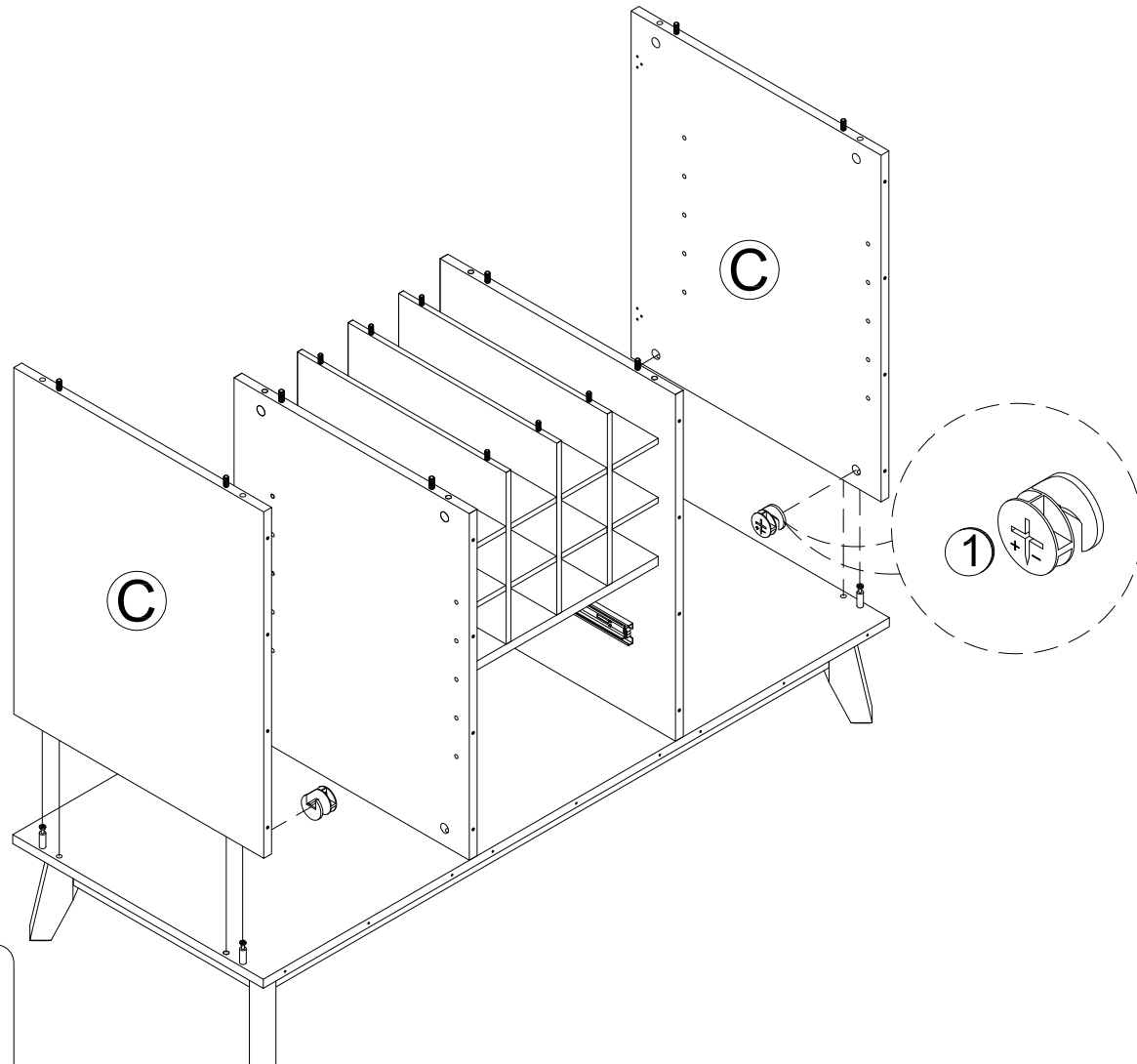

# 13

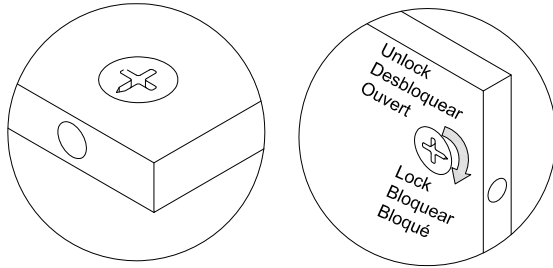

Proper orientation of cam lock  
La orientación apropiada para el seguro de bloqueo  
Bonne orientation du dispositif de blocage à came

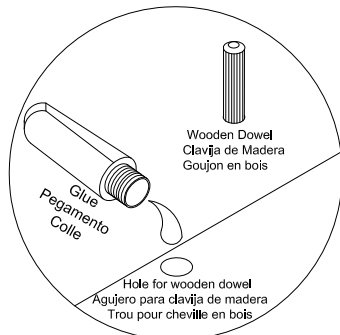

Use one drop of glue in dowel hole.  
Use una gota de pegamento en el agujero de clavija.  
Utilisez une goutte de colle dans le trou de la cheville

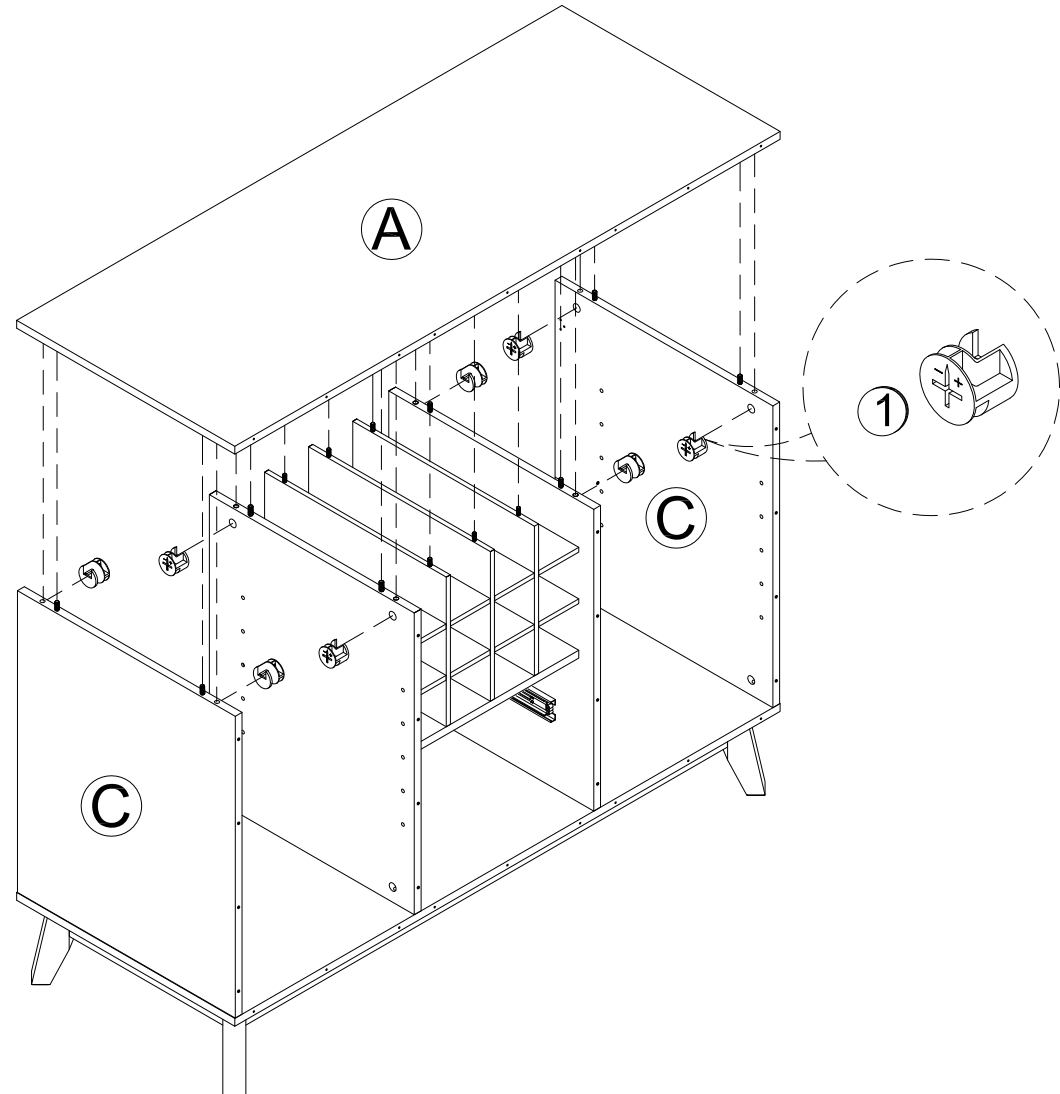
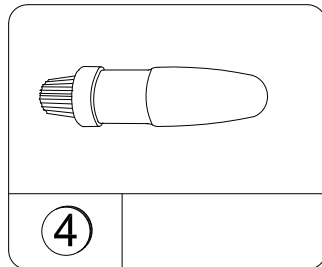
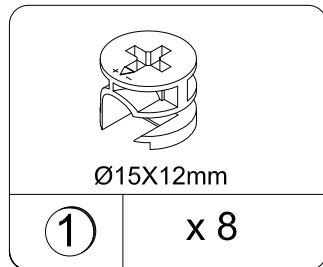

# 14

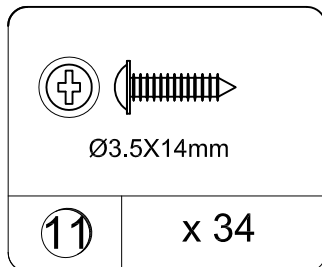
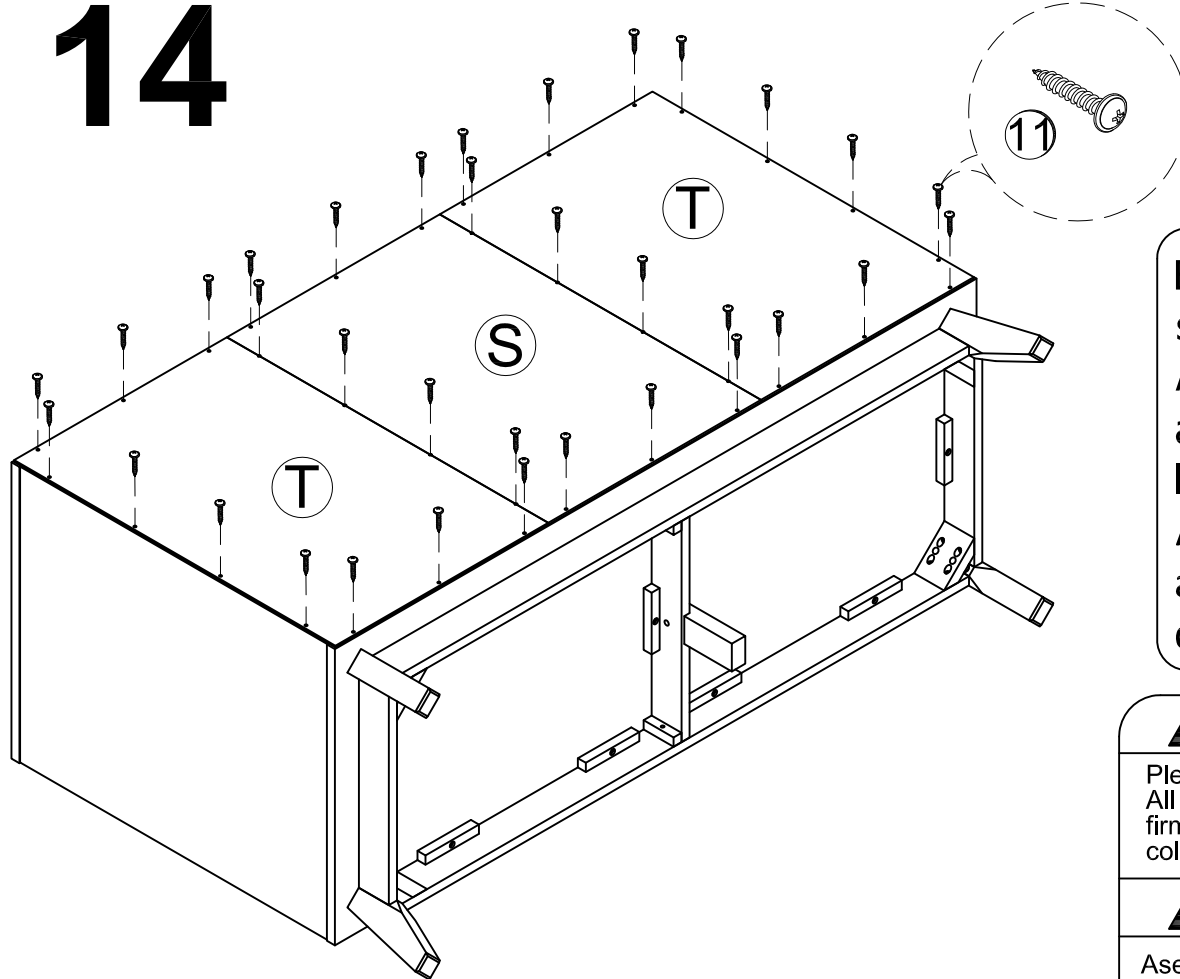

Before attaching the back panel make sure that it is square to the unit .  
Antes de atar el panel trasero asegúrese de que se encaja bien con la unidad.  
Avant de fixer le panneau arrière, assurez-vous que l'unité est d'équerre à 90°.

## WARNING

Please make sure that the backs are attached securely. All nails must be driven into the parts straight and tightened firmly. Failure to do so could cause instability, product collapse, and/or serious injury.

## ADVERTENCIA

Asegúrese de que los paneles traseros están bien sujetos. Todos los tornillos deben ser atornillados en las partes rectas y estar bien apretados. No hacerlo puede resultar en inestabilidad, derrumbe de mueble y/o lesiones graves.

## AVERTISSEMENT

S'il-vous-plaît assurez-vous que les PANNEAUX ARRIÈRE sont attachés solidement. Tous les clous doivent être enfoncés perpendiculairement et solidement dans les parties. Sinon le meuble peut devenir instable, s'effondrer subitement et/ou causer des blessures graves.

# 15

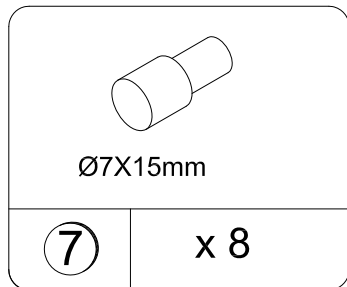
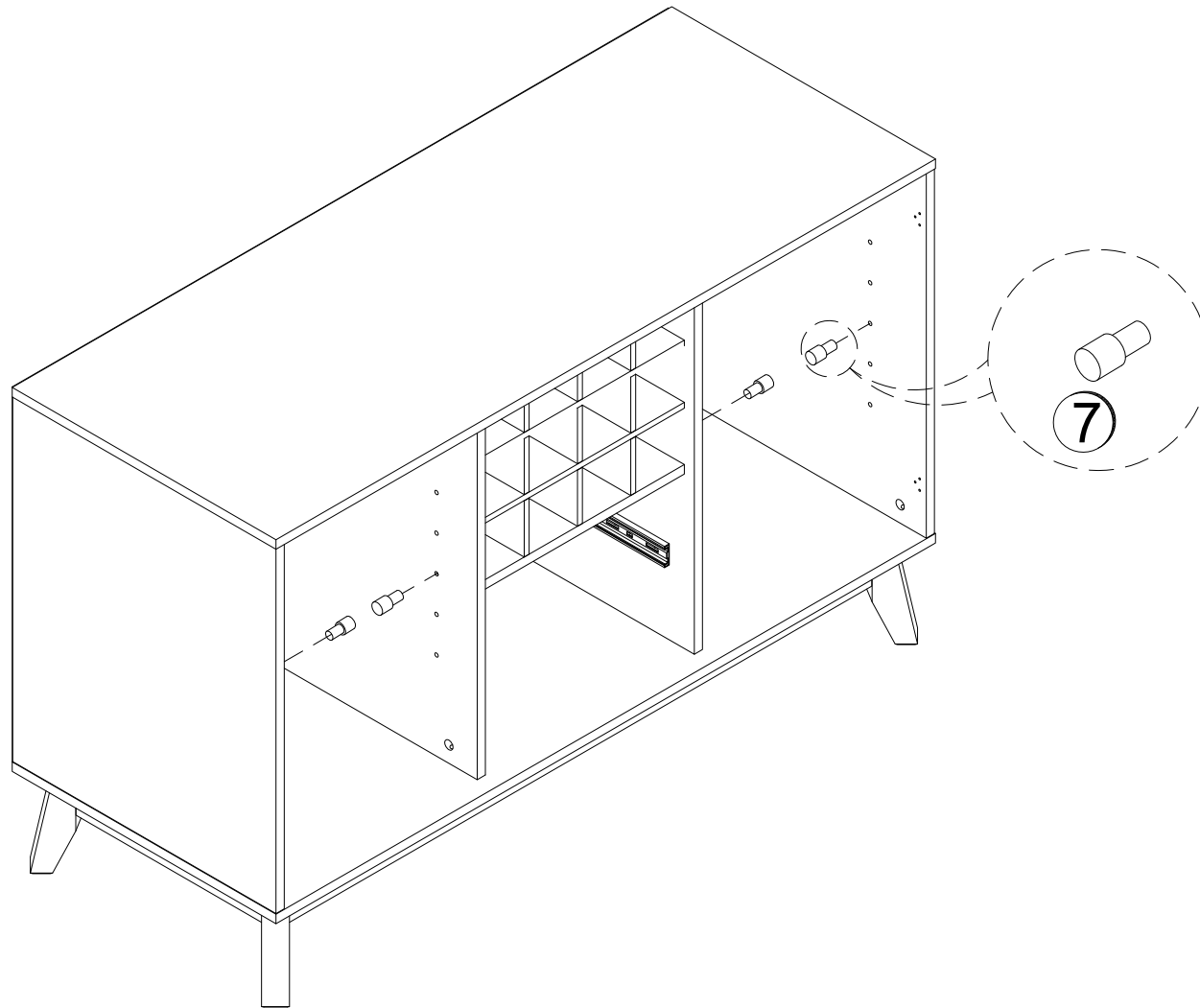

# 16

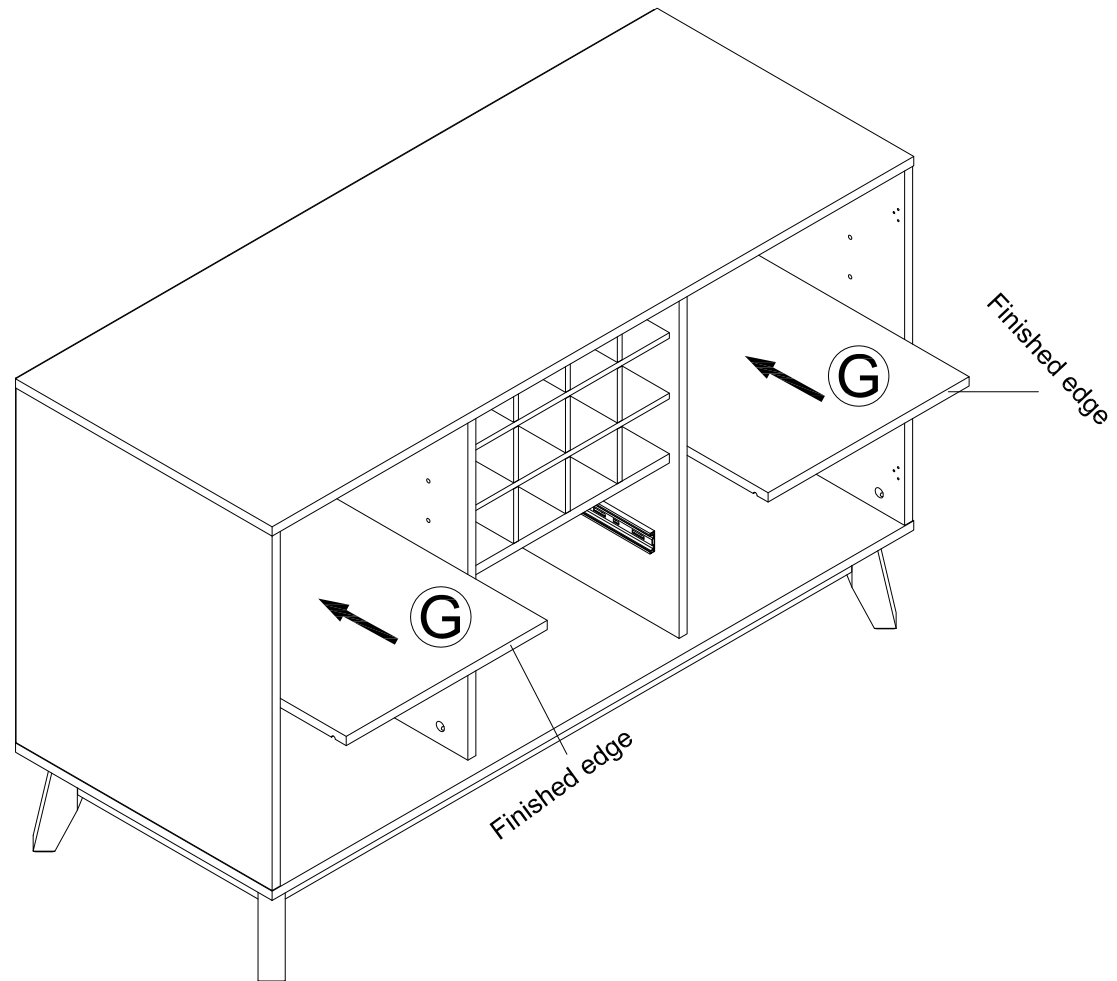

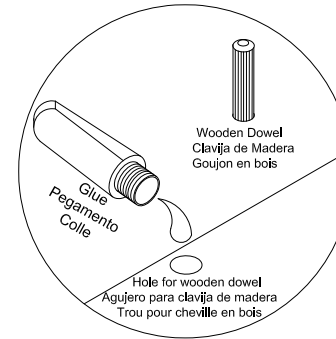
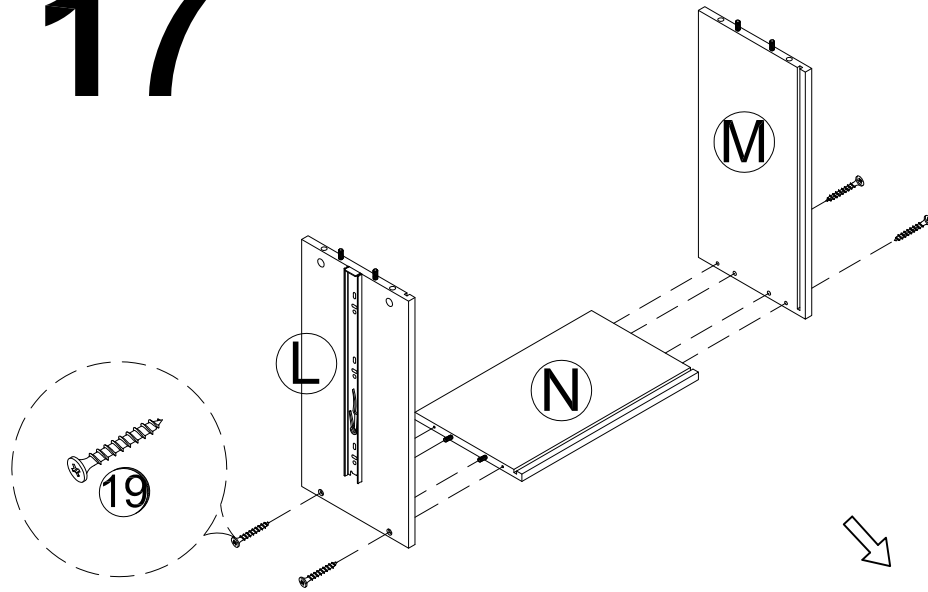

# 17

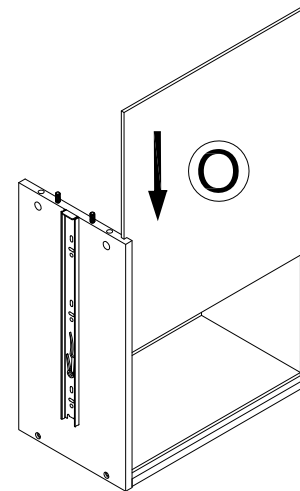

Use one drop of glue in dowel hole.  
Use una gota de pegamento en el agujero de clavija.  
Utilisez une goutte de colle dans le trou de la cheville

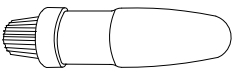

	 Ø4X30mm
④	①9 x 4

# 18

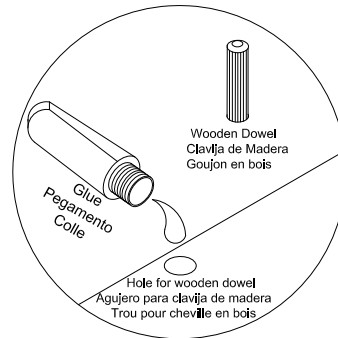
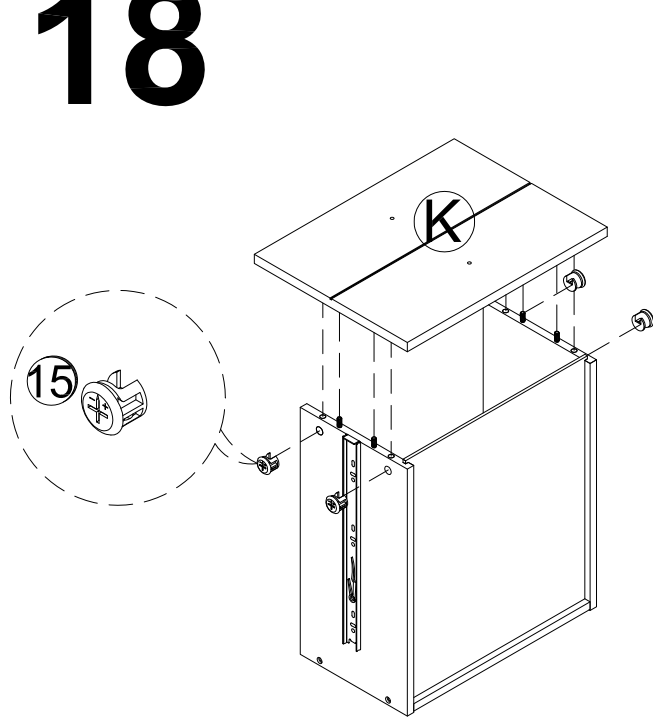

Use one drop of glue in dowel hole.  
Use una gota de pegamento en el agujero de clavija.  
Utilisez une goutte de colle dans le trou de la cheville

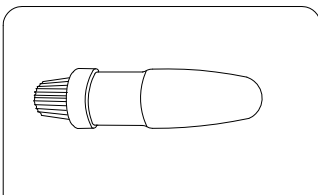
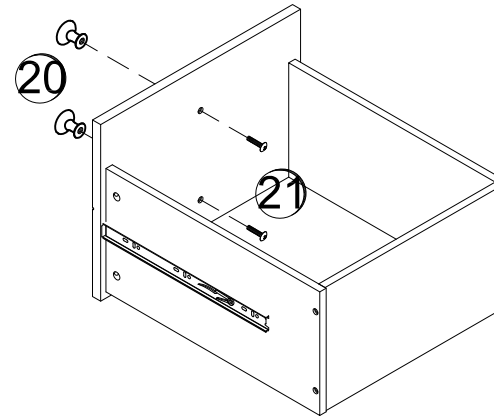

4

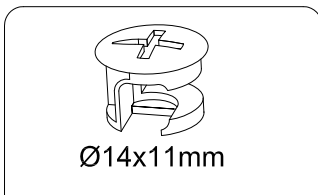

Ø14x11mm

15

x 4

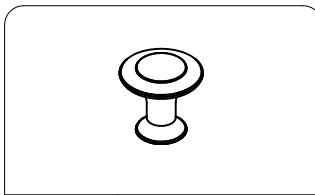

20

x 2

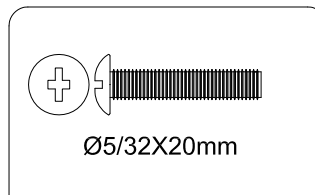

Ø5/32X20mm

21

x 2

# 19

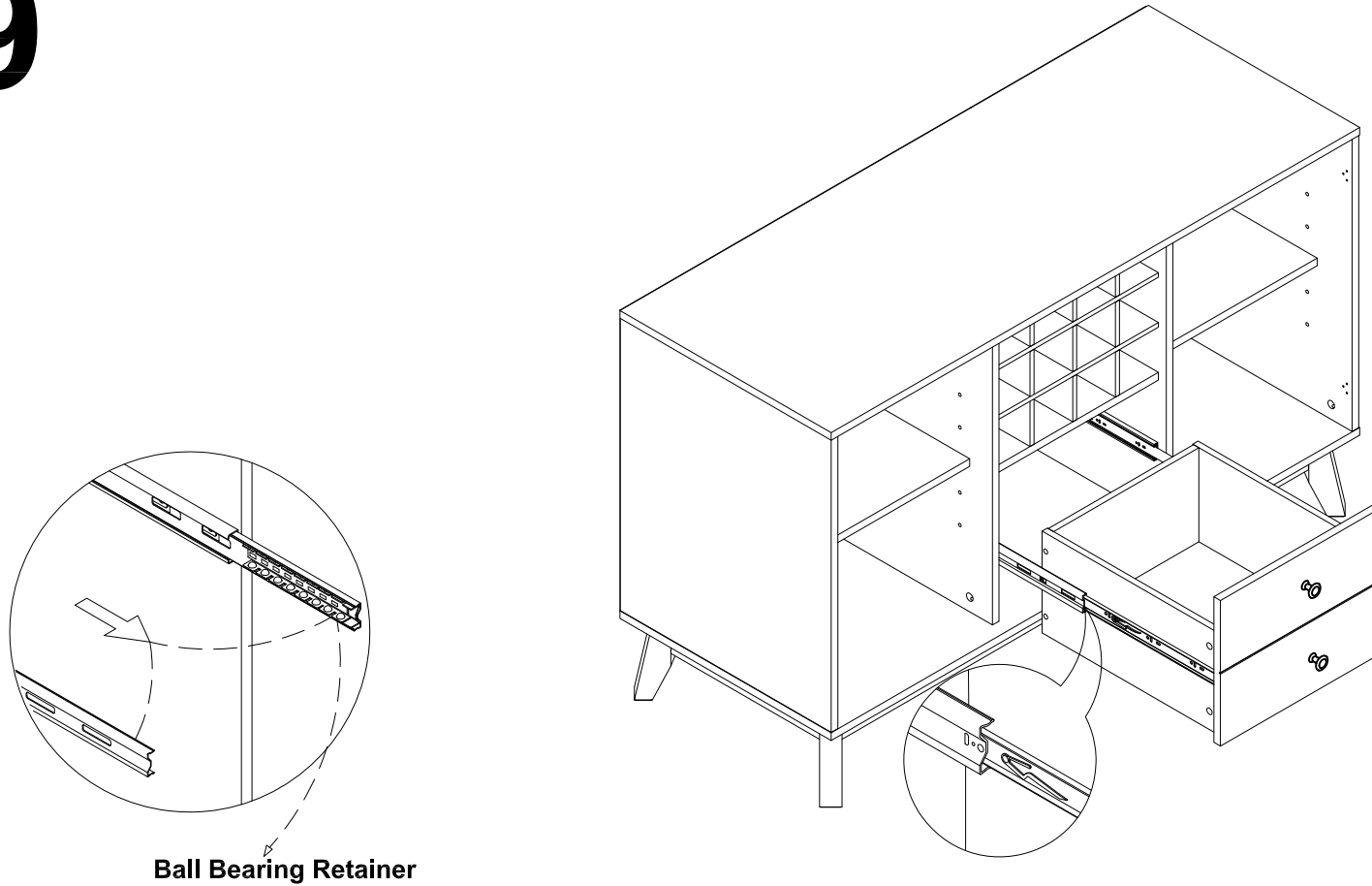

Ball Bearing Retainer

## To Remove Drawer, If Needed

- Pull the drawer fully open so levers are visible.
- Push UP on left side lever and DOWN on right side lever.
- Holding levers in place, pull drawer toward you.

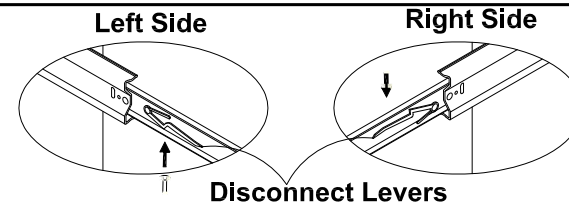

# 20

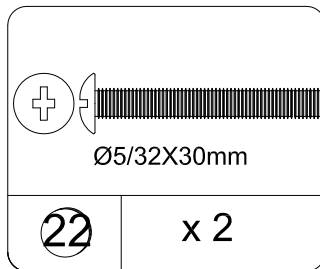
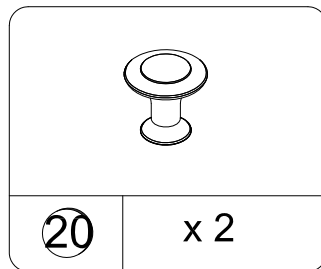
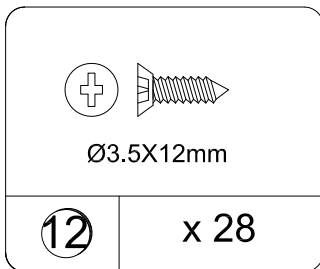
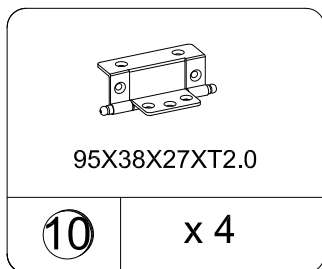
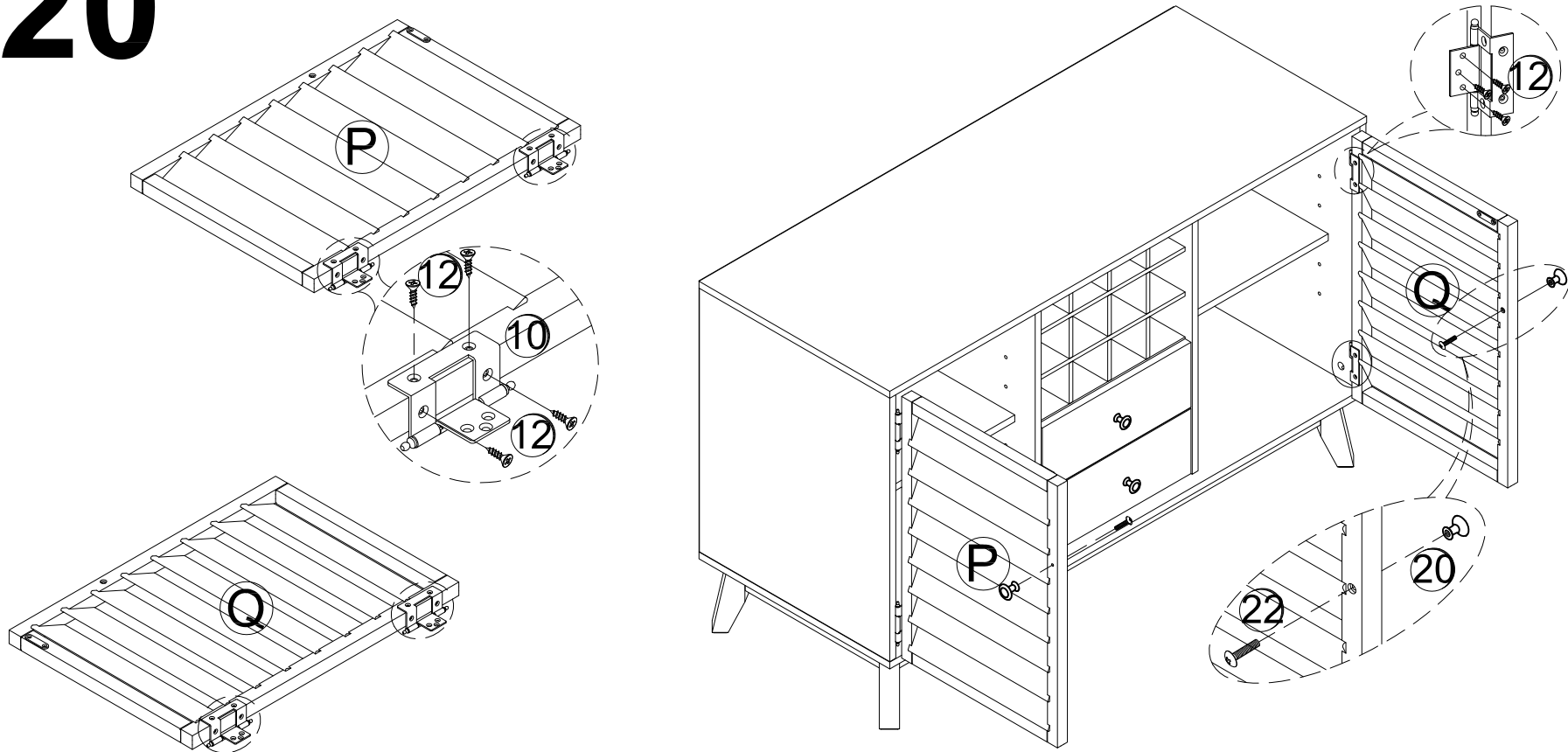

WEIGHT LIMITS:  
LÍMITES DE PESO:  
LIMITES DE POIDS:

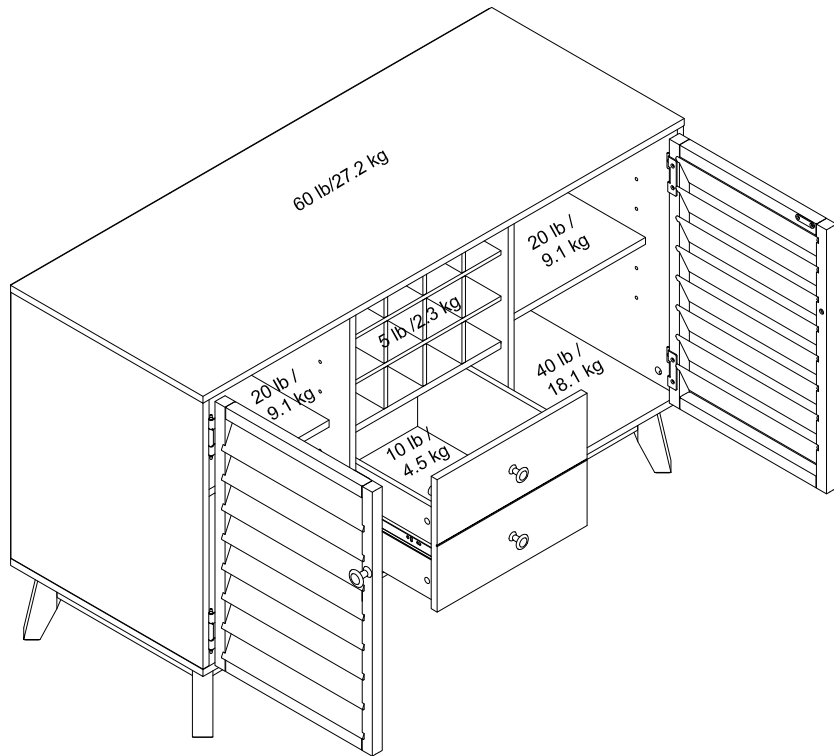

Enjoy Your Furniture  
Disfrute de su mueble  
Profitez de votre mobilier

This unit has been designed to support the maximum loads shown. Exceeding these load limits could cause sagging, instability, product collapse, and/or serious injury.

Esta unidad se ha diseñado para apoyar las cargas máximas mostradas. Exceder estos límites de carga podría causar ceder, inestabilidad, derrumbamiento del producto, y/o lesión seria.

Ce meuble a été conçu pour supporter les charges maximales indiquées. Le dépassement de ces limites de poids peut causer l'affaissement, l'instabilité, l'effondrement du produit, et/ou des blessures graves.

**▲ WARNING**

Please make sure that all objects are removed before moving the assembled unit.

The unit must be team lifted, not dragged or pushed.

Failure to do so could cause instability, product collapse, and/or serious injury.

**▲ ADVERTENCIA**

Por favor mueva el mueble cuidadosamente con la ayuda de otra persona. Levante y mueva el mueble a su lugar. No lo arrastre o empuje, de lo contrario puede haber inestabilidad en el mueble y este puede colapsar u ocasionar graves lesiones.

**▲ AVERTISSEMENT**

Veillez enlever tous les objets avant de déplacer le meuble. Le meuble doit être soulevé en équipe, et non traîné ou poussé. Le non respect de cet avertissement peut provoquer l'instabilité, l'effondrement du produit, et/ou des blessures graves.