

# **Pressure Balance Shower Faucet Installation Manual**

**W-75(ES)**

# Warranty Duration

All parts of this faucet system are warranted to the original purchaser to be free from defects in material and workmanship under a lifetime limited warranty.

# Repair and Replacement

If the product exhibits defects in material or workmanship under normal use and within the warranty coverage, we will, at our discretion, either repair the product or provide a replacement at no cost to the original purchaser. Please note that proof of purchase (e.g., an invoice) must be presented when requesting service. The warranty does not cover damages resulting from improper installation, misuse, or modifications.

# Exclusions

We shall not be responsible for the following cases:

- Damage to the product caused by improper installation, misuse, unauthorized repair or replacement, or abuse (including damage during shipment).
- Damage to the product caused by improper dismantlement after installation.
- Damage resulting from abnormal water pressure and impurities in water pipes is not covered under this warranty.
- Rust on the product due to insufficient care and maintenance is not covered under this warranty.
- Damage caused by natural disasters such as fire, flood, earthquake, electric storms, etc., is not covered under this warranty.

I hope this helps! If you have any further questions or concerns, please let me know.

# Having Trouble? Contact us.

✉ Email: [info@faucetsupport.com](mailto:info@faucetsupport.com)

☎ Toll Free: 1-888-969-6880



**M6968**  
**SFS-1130**  
**Model:A**

## **CONTENT**

**1.Install the Pressure Balance Valve Shower Set ----- (1-6)**

## **CONTENIDO**

**1.Instalar el Juego de Ducha con Válvula de ----- (7-12)**  
**Equilibrio de Presión**

## ◆ Installation and Maintenance Matters

1. Check the accessories list to verify that all parts are complete in this package.
2. Do not disassemble the main body by yourself.
3. Connect inlet pipes to supply valves.
4. Make sure inlet pipes and supply valves have no impurities and are cleaned, with no impurities in the pipeline.
5. After installation, check all joints for leakages.
6. Do not leave the rain shower system exposed to a severely corrosive environment.

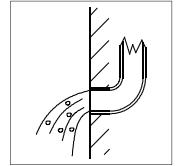
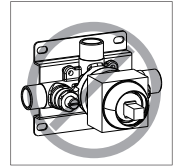

### Do's

1. In order to keep the mixer surface bright, please clean the mixer regularly.
2. Rinse the faucet with clean water and wipe it with a soft cotton cloth.
3. Use one of the following cleaners to remove dirt from the surface: a. Mild liquid cleaner. b. Colorless glass cleaner and powder cleaner that do not cause abrasion and can be dissolved completely. c. Polish liquid that does not cause abrasion.

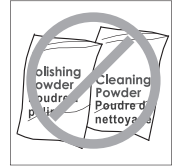

### Don'ts

- a. Avoid using cleaning powder, harsh cleaning chemicals, brushes and coarse cloth to prevent scratching and friction.
- b. Do not use acid cleaners to clean the faucet as they may cause surface corrosion of the faucet. If the faucet is exposed to harmful acid substances, please rinse it immediately with water.

### Tools Needed:

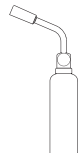
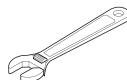
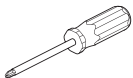

# ◆ Single-function Rain Shower System

Model:A

## Accessories List

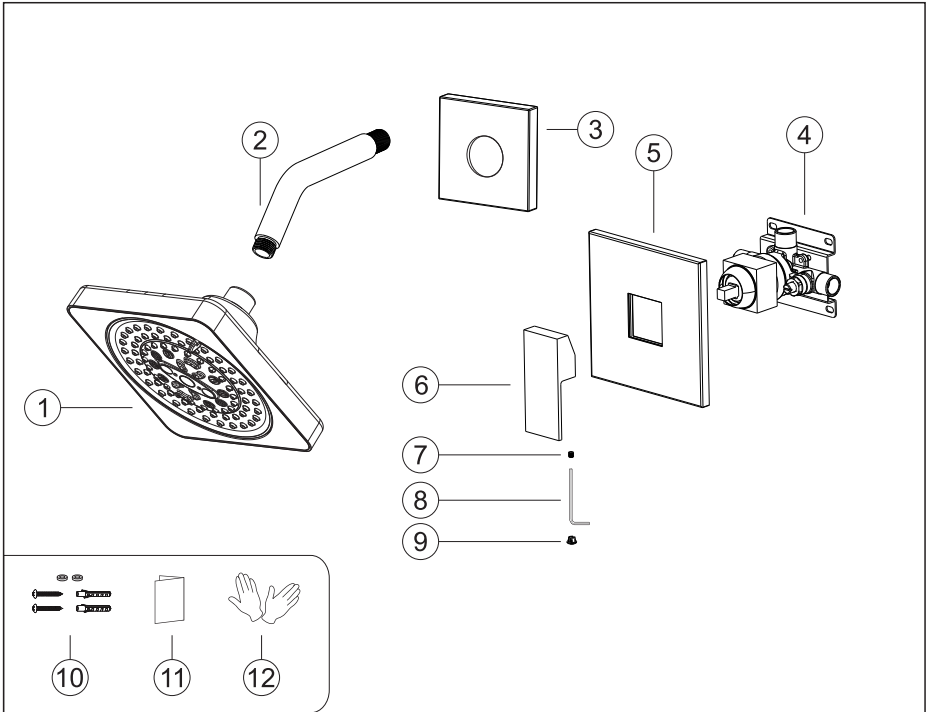

No.	Part name	Qty	No.	Part name	Qty
1	Shower head	1	7	Handle screw	1
2	Shower arm	1	8	Handle wrench	1
3	Shower arm flange	1	9	Handle cap	1
4	Main body	1	10	Main body spare parts	1set
5	Deck plate	1	11	Instruction manual	1
6	Handle	1	12	Gloves	2

## ◆ Essential Dimensions & Water Pipe Line

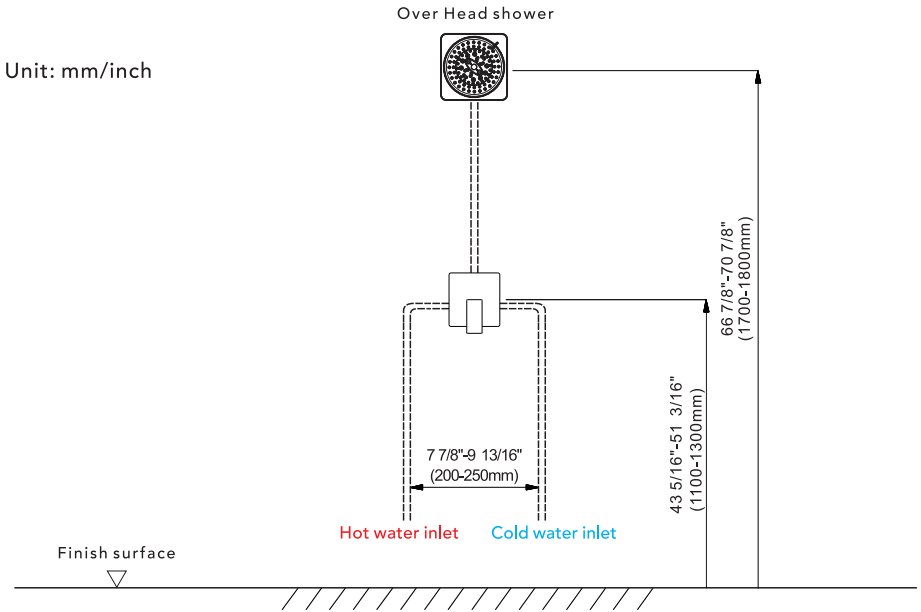

## ◆ The Installation Depth of Shower Arm

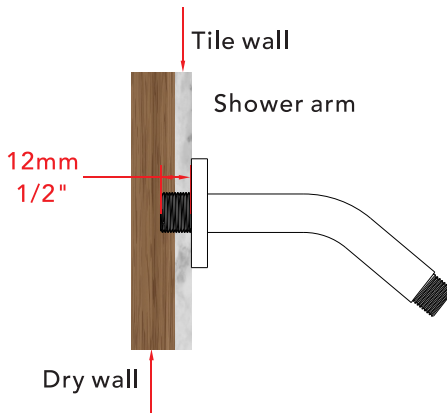

The thickness of the tile must be calculated for installation.

Connector size of male thread: USA: 1/2"-14NPT, Canada: 1/2"-14NPT, Europe: G1/2".

## ◆ The Installation of the Shower Arm

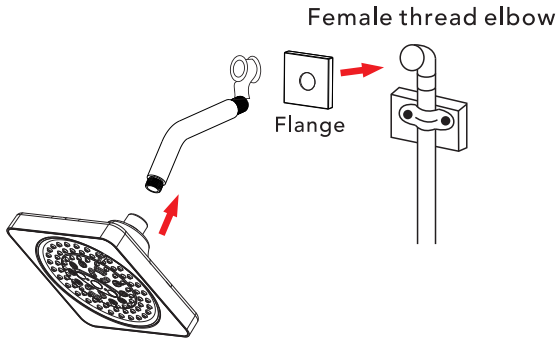

1. Connect the shower arm to the flange before screwing it into the riser connection to prevent damage.
  2. Attach the showerhead to the shower arm and apply plumber's tape to the pipe threads on both ends.
  3. Do not over tighten the showerhead, as it features a 360° swivel connection.
- 

## ◆ Seven-function Small Overhead Spray Description

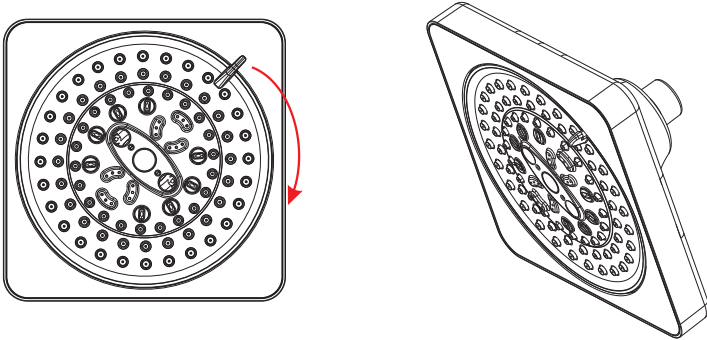

1. Hold the selector lever and rotate it in the indicated direction to switch between up to seven spray patterns.

## ◆ Installation Depth of Main Body

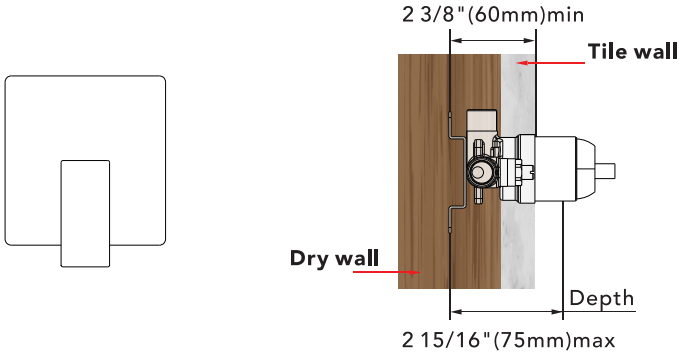

- Notice:** 1. The installation depth of the main body should be no less than  $2 \frac{3}{8}$ " (60mm) and no more than  $2 \frac{15}{16}$ " (75mm), including the thickness of the tile. Otherwise, the deck plate cannot be installed.
2. The opening size of ceramic tile shall be smaller than the deck plate size.

## ◆ Piping Instructions Before Tiling

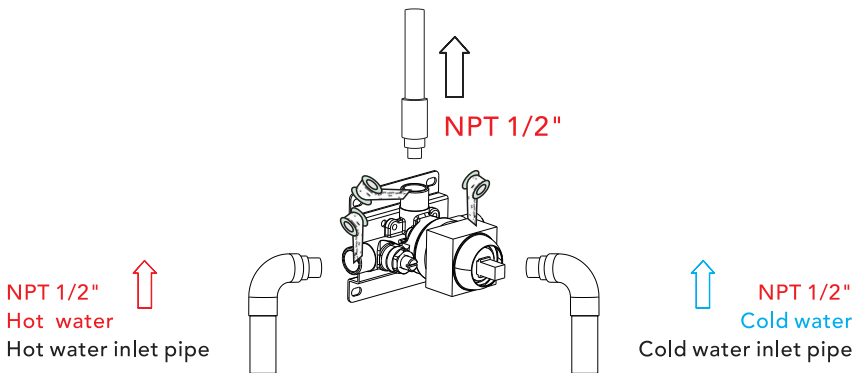

1. As shown in the figure, the inlet and outlet pipes are pre-buried. Please pay attention to the correct direction when installing the pre-buried main body.
2. Before tiling, turn on the water to test whether the left and right inlet pipes are tightly connected without leakage. Then, adjust the flow switch to the "on" position to check for leaks in the mixed outlet pipes.

## ◆ Main Body Valve Installation

### Step1

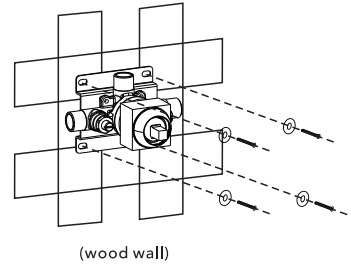
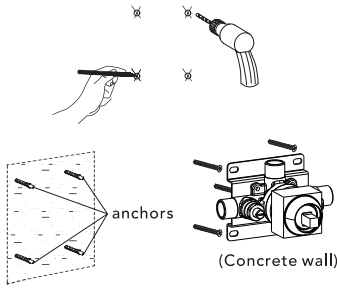

1. Make marks according to the size of the main body valve, and then drill anchors into the wall (concrete wall).
  2. Lock the main body to wood directly with screws (wood wall).
  3. When installing the main body, please mark the UP side up and do not install it upside down.
    - ▲ Please note that the level meter should be parallel to the wall; otherwise, the deck plate cannot be installed.
-

## ◆ Instalación y cuestiones de mantenimiento

1. Verifique la lista de accesorios para comprobar que todas las partes están completas en este paquete.
2. No desmonte el cuerpo principal por sí mismo.
3. Conecte las tuberías de entrada a las válvulas de suministro.
4. Asegúrese de que las tuberías de entrada y las válvulas de suministro no tengan impurezas y estén limpias, sin impurezas en la tubería.
5. Después de la instalación, revise todas las juntas en busca de fugas.
6. No deje el sistema de ducha expuesto a un ambiente severamente corrosivo.

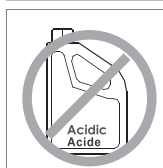
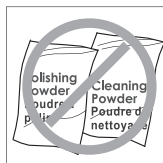
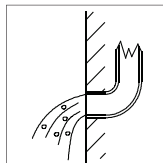
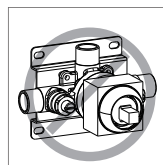

### Hacer

1. En para mantener la superficie de la batidora brillante, limpie el mezclador regularmente.
2. Inse el grifo con agua limpia y límpielo con un suave ropa de algodón.
3. Use uno de los siguientes limpiadores para eliminar la suciedad de la superficie:  
A. Mild Liquid Cleaner.  
B. Cleaner de vidrio sin color y limpiador de polvo que no cause abrasión y se puede disolver por completo.  
C. Polish Líquido que no causa abrasión.

### No es decir

- A. Valte con polvo de limpieza, productos químicos de limpieza duros, cepillos y tela gruesa para evitar rasgar y fricción.
- B. No use limpiadores de ácidos para limpiar el grifo, ya que pueden causar corrosión superficial del grifo. Si el grifo está expuesto a sustancias ácidas dañinas, enjuague inmediatamente con agua.

## HERRAMIENTAS NECESARIAS:

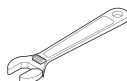
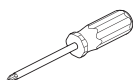

# ◆ Sistema de Ducha de Lluvia de Función Única

Modelo:A

## Lista de Accesorios

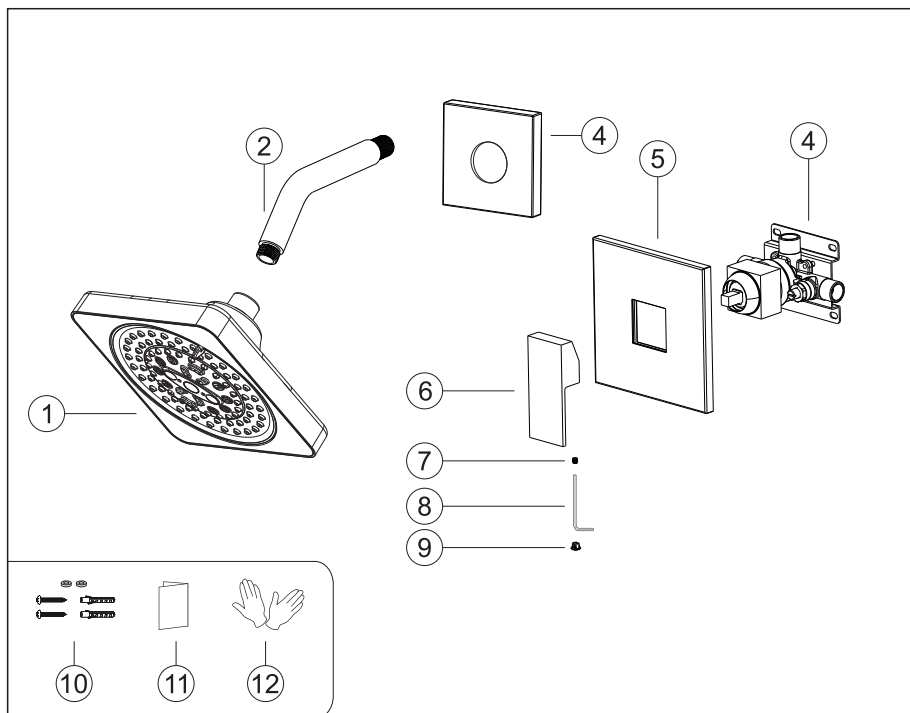

N.º	Nombre de la pieza	Cantidad	N.º	Nombre de la pieza	Cantidad
1	Alcachofa de la ducha	1	7	Tornillo de la manija	1
2	Brazo de ducha	1	8	Llave de la manija	1
3	Taza de brazo de ducha	1	9	Tapa de la manija	1
4	Cuerpo principal	1	10	Repuestos del cuerpo principal	4
5	Placa de cubierta	1	11	Manual de instrucciones	1
6	Manija	1	12	Guantes	2

## ◆ Dimensiones esenciales & línea de tubería de agua

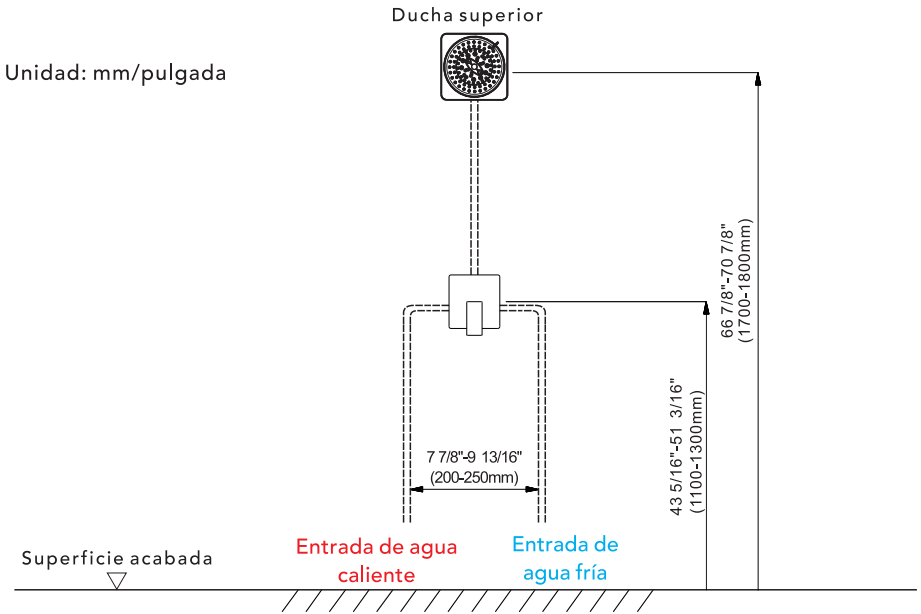

## ◆ La profundidad de instalación del brazo de ducha

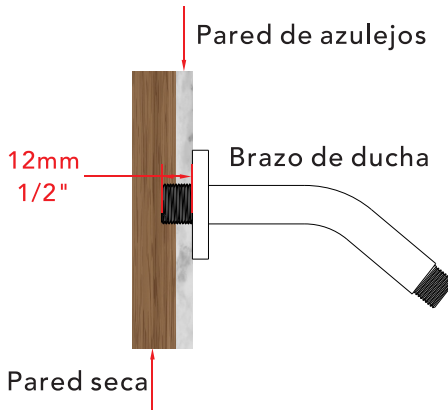

El grosor del azulejo debe ser calculado para la instalación.

Tamaño del conector de rosca macho: EE. UU.: 1/2"-14NPT, Canadá: 1/2"-14NPT, Europa: G1/2".

## ◆ La instalación de la ducha superior

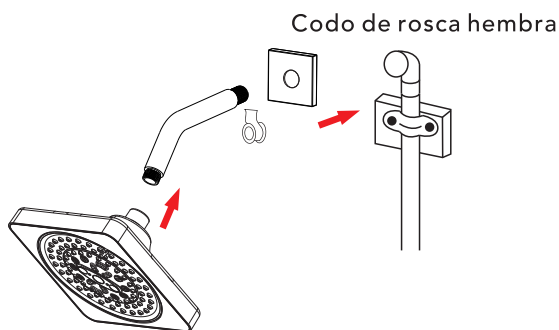

1. Conecte el brazo de ducha con la cubierta antes de enroscarlo en la conexión del tubo de subida para evitar daños.
  2. Fije la cabeza de ducha al brazo de ducha y aplique cinta a las roscas de la tubería en ambos extremos.
  3. No apriete demasiado la cabeza de ducha. Tiene una conexión giratoria de 360°.
- 

## ◆ Descripción de la pequeña ducha superior de siete funciones

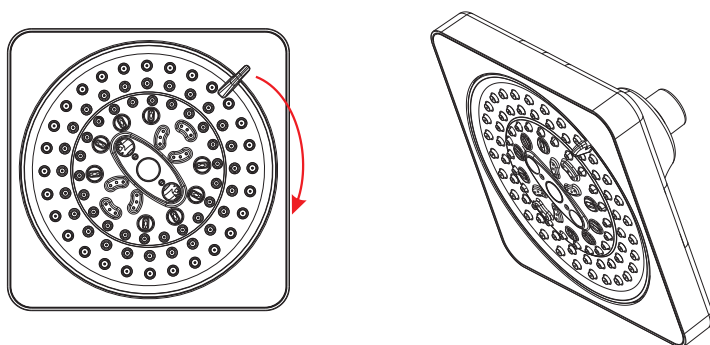

1. Sujete la palanca selectora y gírela en la dirección indicada para cambiar entre hasta siete modos de rociado.

## ◆ Profundidad de Instalación del Cuerpo Principal

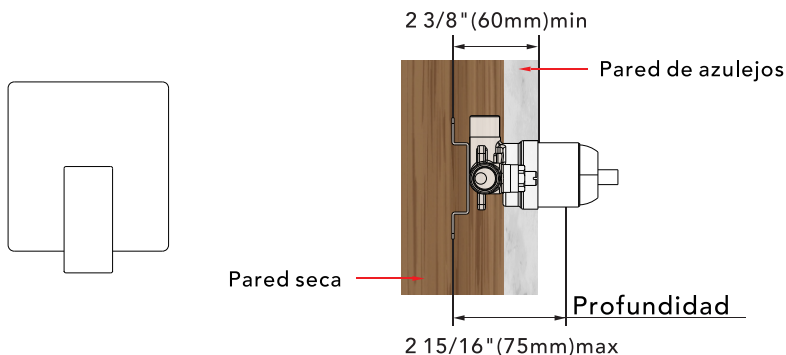

- Aviso: 1. La profundidad de instalación del cuerpo principal no debe ser inferior a 2 3/8" (60 mm) y no más de 2 15/16" (75mm), incluyendo el grosor del azulejo. De lo contrario, la placa de cubierta no podrá ser instalada.
2. El tamaño de apertura del azulejo cerámico debe ser menor que el tamaño de la placa de cubierta.

## ◆ Instrucciones de Tubería Antes de Colocar Azulejos

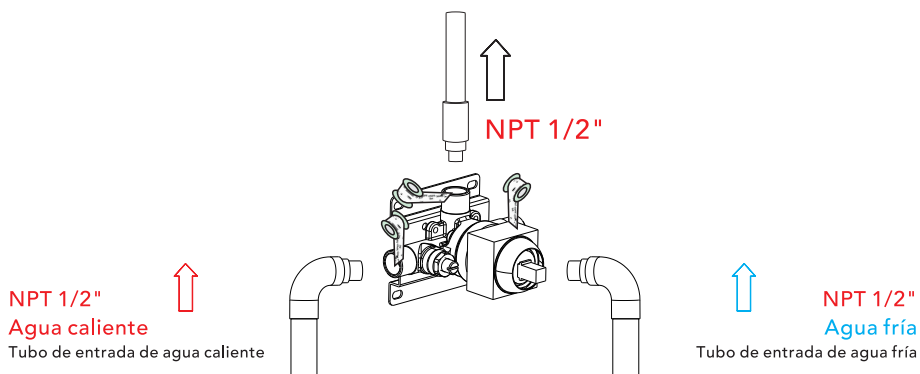

1. Como se muestra en la figura, las tuberías de entrada y salida están pre-enterradas. Por favor, preste atención a la dirección correcta al instalar el cuerpo principal pre-enterrado.
2. Antes de colocar los azulejos, abra el agua para probar si las tuberías de entrada izquierda y derecha están conectadas herméticamente sin fugas. Luego, ajuste el interruptor de flujo a la posición "on" para comprobar si hay fugas en las tuberías de salida mezcladas.

## ◆ Instalación de la Válvula del Cuerpo Principal

### Paso 1

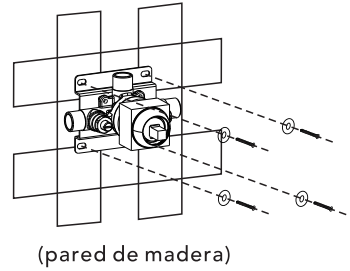
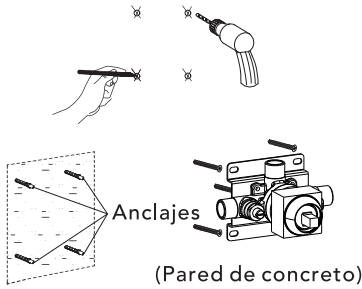

1. Marque según el tamaño de la válvula del cuerpo principal y luego perfore para colocar los anclajes en la pared (pared de concreto).
  2. Fije directamente el cuerpo principal a la madera con tornillos (pared de madera).
  3. Al instalar el cuerpo principal, por favor marque el lado UP hacia arriba y no lo instale al revés.
- ▲ Tenga en cuenta que el nivel debe estar paralelo a la pared; de lo contrario, la placa de cubierta no podrá ser instalada.
-