



20 : 00

estimated assembly



2 or more

people required

Ok, let's
get started!



- Put on mood music!
- To prevent damage to product, use the clean side of package carton or rug as working surface.
- In the event of missing or damaged parts, delivery problems etc., please reach out to our team. We will be happy to fix the problem!

care guide

- Clean regularly with a soft and dry cloth.
- To protect finish, avoid use of abrasive cleaners.
- Wipe up spills immediately. Please!



product
parts

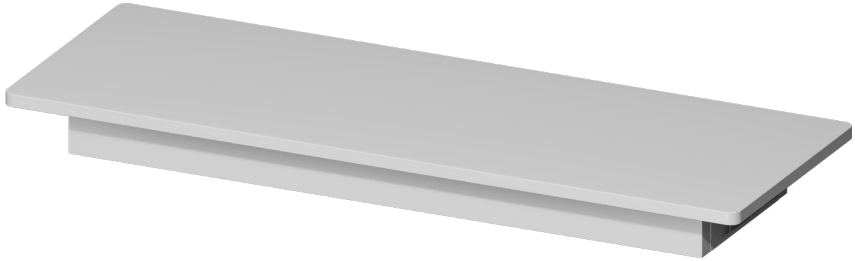

(A)
Table Top
x1

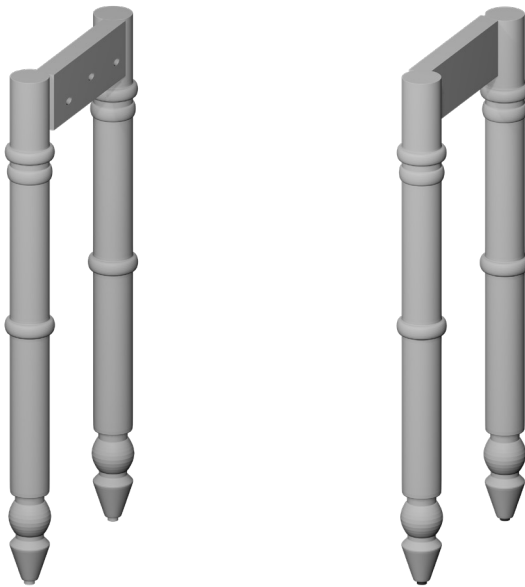

(B1, B2)
Table legs
x2

what's included



(C)- L Key Bolt
(8 x 35mm)
x6



(D)- Plain Washer
(8 x 20mm)
x6



(E)- Lock Washer
(8 x 16mm)
x6



(F)- Allen Key
(5mm)
x1

OS

Orange sticker

GS

Green sticker

assembly instructions

Friendly Tip: Take a deep breath going in. This may be a tricky part, but nothing too overwhelming. Just follow these steps to the T and the outcome will be worth it!



- ⓘ While assembling the product, tighten the bolts up to 50%. Once all parts are in place, only then fully tighten the bolts.

step 1:

Start by placing the tabletop (A) upside down on the ground (make sure that surface should be clean). Now, align the leg (B1) with the tabletop, so that the slots on (A) align with slots on (B1). Take the image below as a reference.

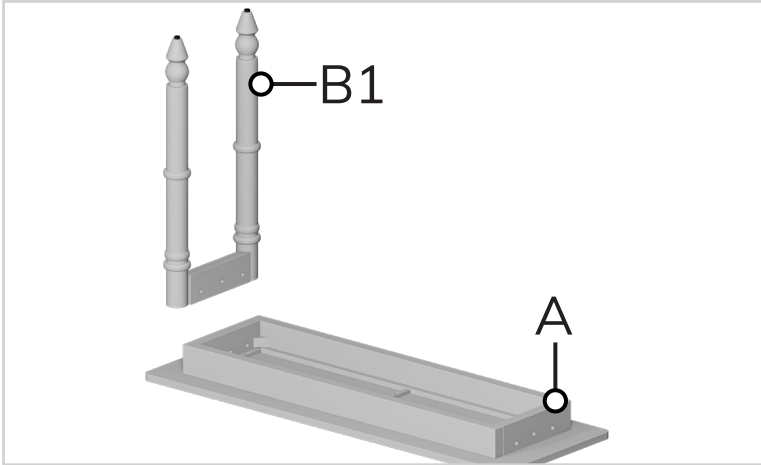

step 2:

Now, attach both leg (B1) with the table top (A) by inserting plain washer (D), lock washer (E), and bolts (C) in the given slots. Tighten the bolt using allen key (F).

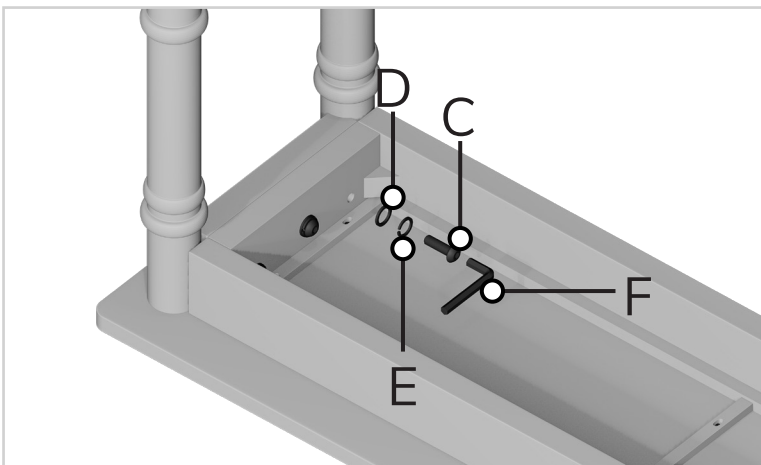

step 3:

Repeat the same process with the remaining leg (B2).

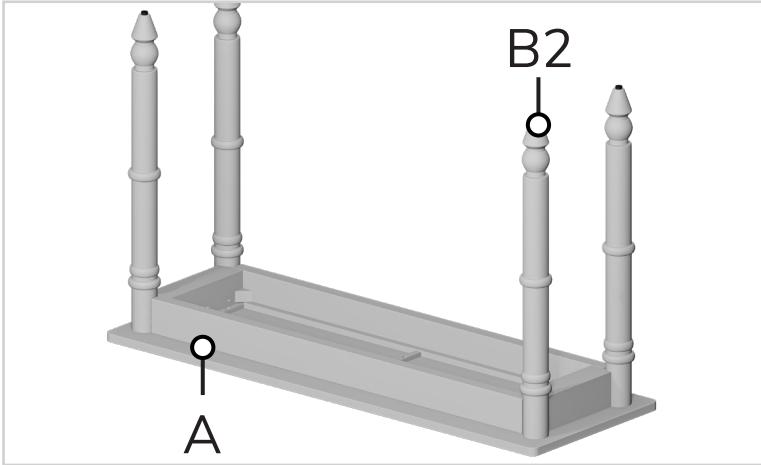

step 4:

If required, adjust the levellers according to the floor as shown in the image.

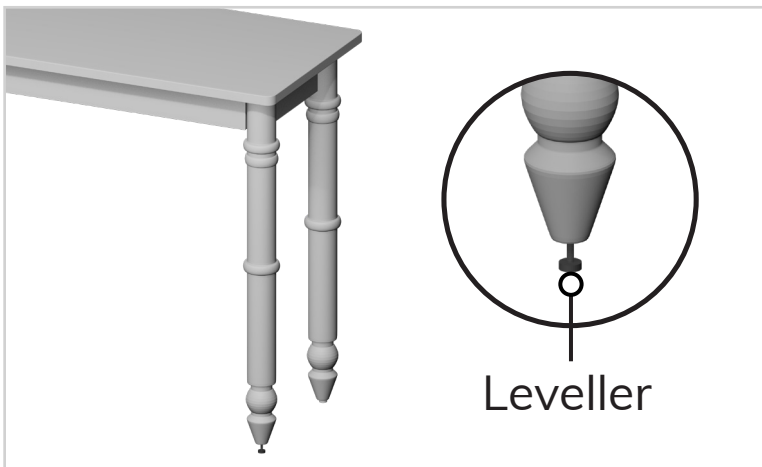



Voila! Your console table is now assembled and secure!

you've
got
a home
with us

