

WARRANTY

- We strive to offer quality products, and we also try our best to satisfy every customer who orders from us with products or services as needed.
- We provide 30 days warranty starting from the time you receive the item. Each customer must provide a record of their orders such as the order number, or item receipt for any items that are out of the warranty period you may also still receive.
- Replacement parts by purchasing them from our company if they are available.
- For return, please check the return policy with the retailer or market place you bought from.

Are you having difficulty

With assembly? Missing parts?
Please send an email with your order No. to
hello@hulalahome.com

Appreciate your purchasing from us.
Pop up your life by our furniture piece!

HULALA

HOME

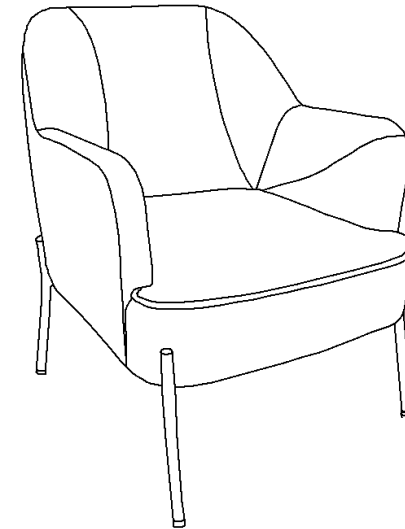

Per Seat Weight Limitation

300 LBS

ITEM NO. CHM6154A

Thank You For Choosing Our Furniture

▾ If you have any questions or concerns,
don't hesitate to reach out to us. ▾

Call us: +1(833)324-2464
Email: hello@hulalahome.com

NOTE:

This brochure contains
IMPORTANT safety info.
Please read and keep it
for future reference.

MAINTAINANCE AND WARNINGS



Before You Start

Please follow the steps below:

- ⚠ Un box the package and check if all parts and accessories are complete.
- ⚠ Place the parts of the chair on a flat surface.
- ⚠ Ensure the chair is placed on a stable, flat surface to prevent it from tilting.
- ⚠ Avoid placing sharp or heavy objects directly on the chair to prevent tears or deformation.
- ⚠ Clean the installation area in advance and ensure the ground is level and there is enough space to avoid damaging the furniture or making installation difficult.
- ⚠ Lay a protective mat on the ground to prevent scratching the floor during installation.

After-Sales Service

- If you encounter any issues or need technical support during use, please contact our after-sales team. We offer long-term maintenance and warranty services.



Precautions

- ⚠ This chair is for indoor use only. Do not expose it to outdoor elements or high-humidity environments.
- ⚠ Keep the product away from high heat or open flames to prevent fire hazards.
- ⚠ Do not allow children or pets to play on the chair unsupervised to avoid accidents.





Safety Warnings

- ⚠ If you notice any loose or damaged parts, stop using the sofa immediately and contact customer service.
- ⚠ Do not attempt to disassemble or replace any components yourself, as this may affect the stability and safety of the product.

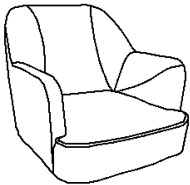
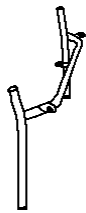

Daily Maintenance

- Regularly clean the surface of the sofa with a chair cloth to prevent dust accumulation.
- For fabric chairs, it is recommended to vacuum weekly and clean the fabric as needed.
- For leather chairs, use a leather cleaner regularly to clean and maintain the material. Avoid direct sunlight to prevent leather aging.
- In case of spills, immediately blot the area with a clean, dry cloth



Parts List

A	x1	B	x1	C	x1
					
Seat		Left legs		Right legs	

Hardware List

D	x6	E	x1	
				
Bolt		Allen key		
M6x20mm		M6		

Hardware Spare List

D	X1	D	X1	
				
Bolt		Adjustable leveler		
M6x20mm				

3



Installation:
15minutes.



Two Person

Step 1

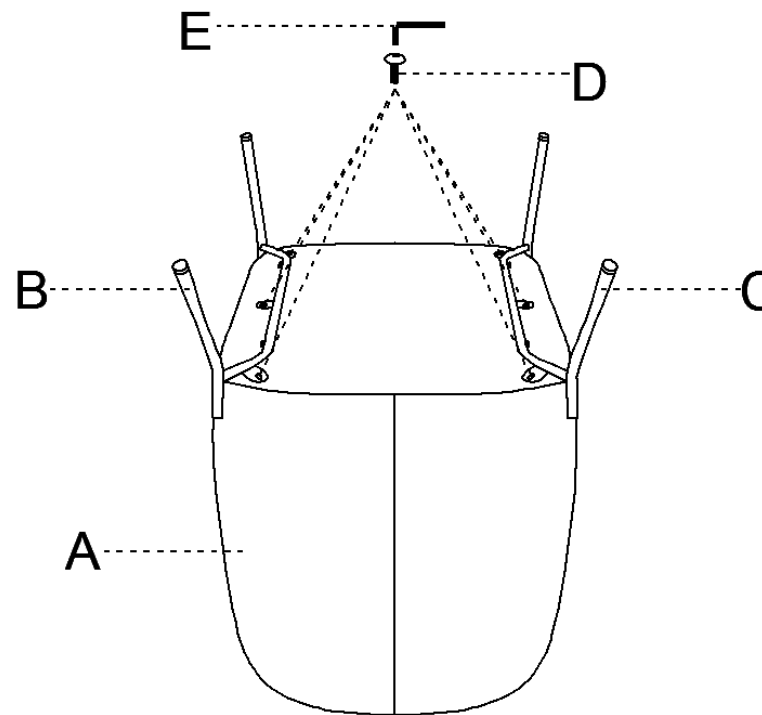
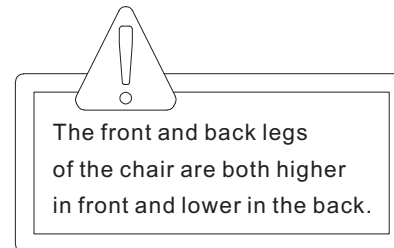

STEP 1:Place the Chair Back A on a clean padded surface.Use bolt D,allen key E to connect the metal base to bottom of the seat cushion A, fasten all bolts to secure.

4

Step 2

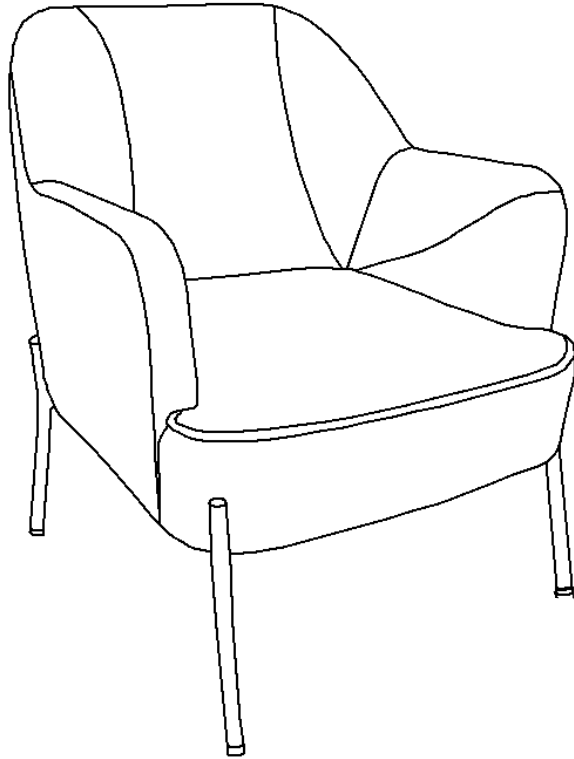

STEP 2:Assembly completed

Step 3

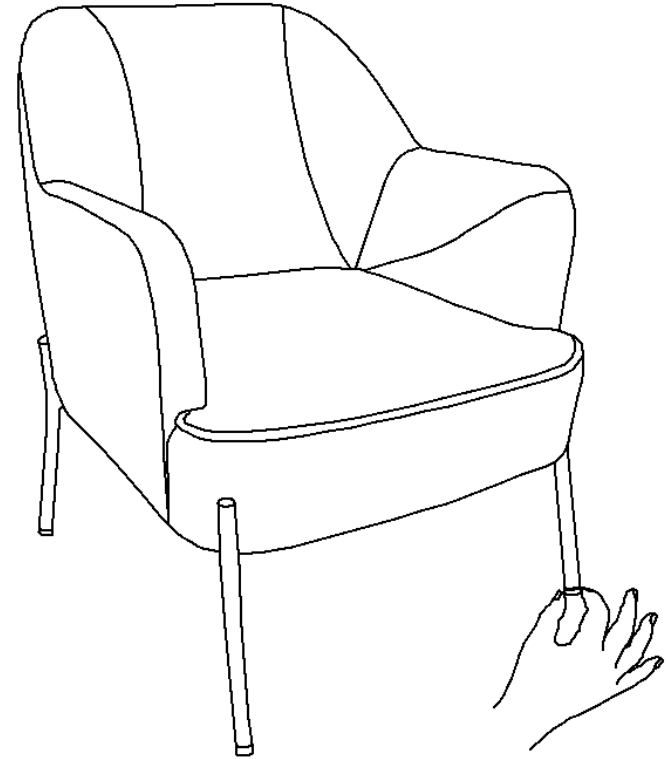

Attention:
After installation, adjust the two foot nails
in front of the chair to keep the chair
balanced !
Be sure to check all packing material carefully for
small parts, which may have come loose inside the
carton during shipment.