

# Invisia™ Accent Bar

with Support Rail

INVISIA  
LIVE BEAUTIFULLY

## Technical Data Sheet

### Product Specification

The product shall be a grab bar with a curved handle. The product shall have flange covers that conceal the mounting hardware. The product shall be of full metal construction. The grab rail portion of the product shall be 1.25"/3.2 cm in diameter. The product shall be suitable for use in a wet environment. The product shall have a weight capacity in excess of 500lbs / 227kg. Product shall comply with ADA Guidelines, specifying the structural strength of grab bars, tubs and shower seats. The grab rail shall be Invisia Collection model INV-ACB-\_\_\_\_ (see table below for appropriate product code).



### Key Features

- Elegant Design with Integrated Support
- Solid Construction and Mounting
- Discreet Wall Mounts that Conceal Mounting Hardware
- Suitable For Use in a Wet Environment
- 500lbs / 227kg Weight Capacity

### Codes and Standards

- ADA 609.2 Cross Section
- ADA 609.3 Spacing
- ADA 609.8 Structural Strength

### Specified Model

Model	Finish	Material
INV-ACB-BS	Brushed	#304 Stainless Steel
INV-ACB-CP	Polished Chrome	
INV-ACB-ORB	Oil Rubbed Bronze	

# Invisia™ Accent Bar

with Support Rail

INVISIA  
LIVE BEAUTIFULLY

## Technical Data Sheet

### Product Dimensions

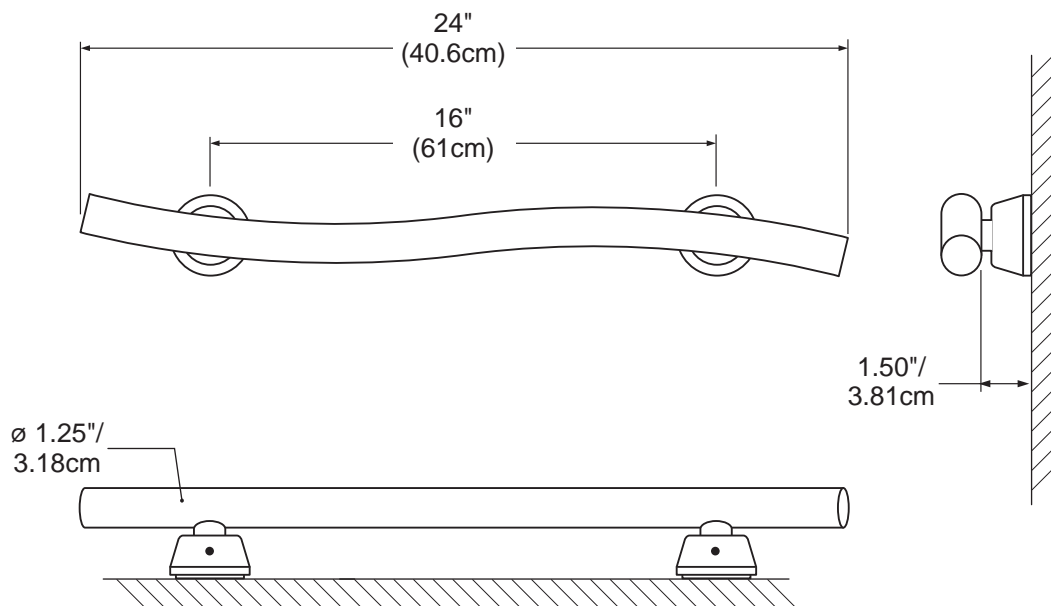

### Shipping Dimensions

Model	Height (H)	Width (W)	Depth (D)	Weight
ACB	3.25" / 8.3cm	26.25" / 66.7cm	3.75" / 9.5cm	3lbs / 1.4kg

