

ASSEMBLY INSTRUCTION

COUNTER STOOL

PARTS LIST	CODE	PARTS	QTY.
	1	BACK	1
	2	SEAT	1
	3	SIDE RAIL (R2,L2)	2
	4	FRONT RAIL (F)	1
5	FRONT LEG (R1,L1)	2	

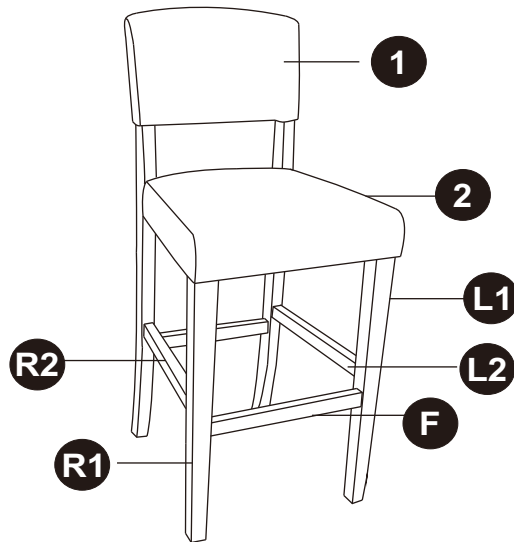

HARDWARE LIST	CODE	PARTS	QTY.
	A	M8x1- $\frac{3}{4}$	1
	B	M8x2- $\frac{3}{8}$	4
	C	M8x3- $\frac{1}{8}$	4
	D	M3.5x1- $\frac{9}{16}$	6
E	ALLEN KEY M6	1	

1

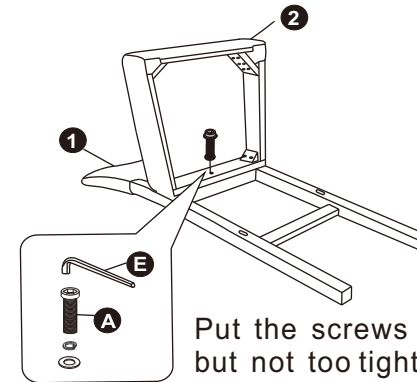

Put the screws in the holes, tight the screws, but not too tight, 90% is ok.

2

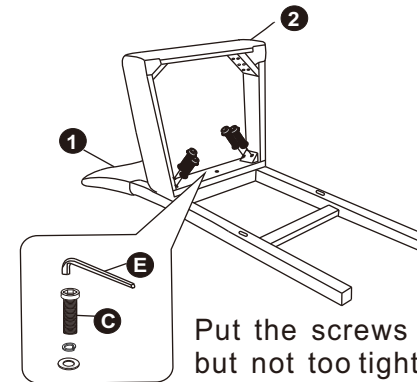

Put the screws in the holes, tight the screws, but not too tight, 90% is ok.

3

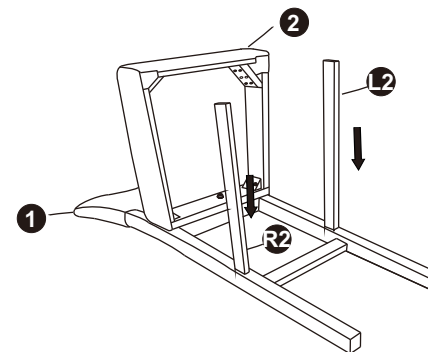

Put the L2 R2 in the holes.

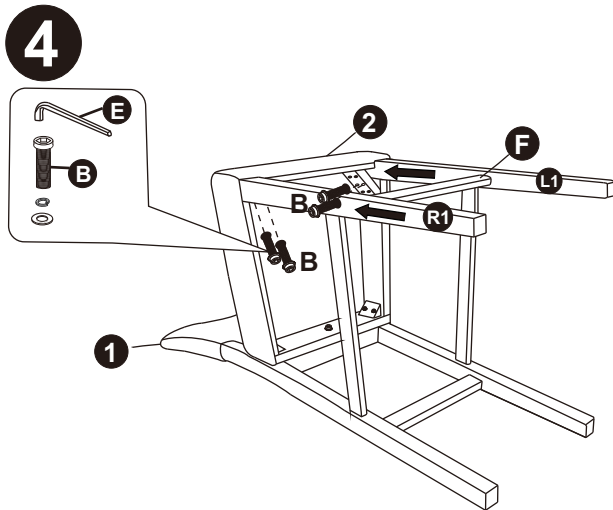

Put L1 and R1 legs in the holes.
Then put F in the holes.
Put the screws in the holes,
tight the screws, but not too
tight, 90% is ok.

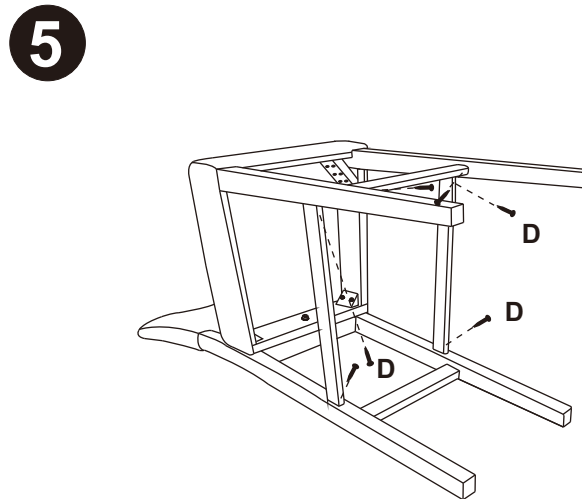

Put the screws in the holes,
tight the screws, but not too
tight, 90% is ok.

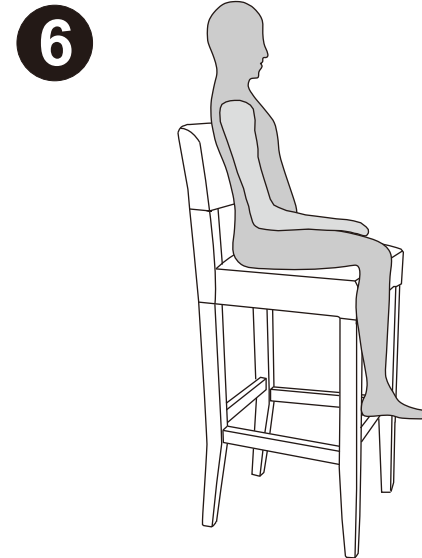

Then adjust the balance
of the chair.

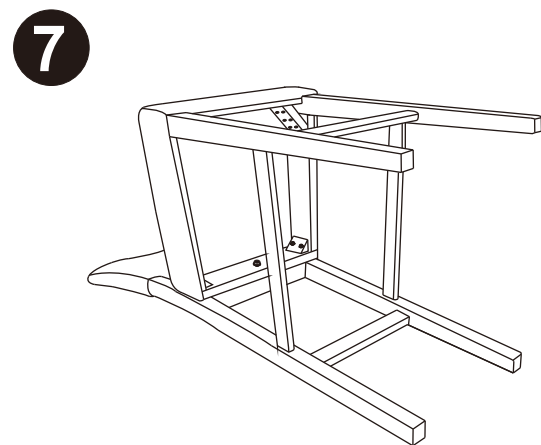

Tight all the screws to 100%

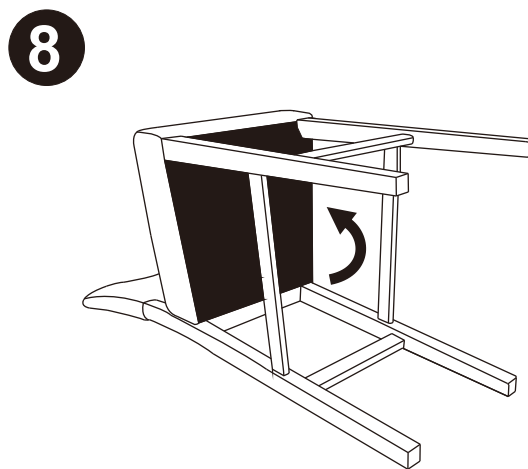

Stick the black part
on the seat