

Read this instruction carefully. See hardware and furniture part list for guidance. Be sure all parts are complete, before you assemble. Place all wooden furniture parts on a clean and flat soft surface to prevent from being scratched. Follow the figure to start assembling.

CAUTIONS : 1. Do not FULLY - TIGHTEN the nut or nut bolt until all nut or bolt is ready assembled.
 2. Do not OVER - TIGHTEN the nut or bolt to avoid causing damages to the thread.
 3. Keep all hardware parts out of reach of children.

NOTE : THE LIST AND QUANTITY SHOWN ARE FOR 1 UNIT ASSEMBLY.
 Tool needed : Screwdriver (not provider).

| PART LIST | | |
|-----------|--------------------|--------|
| ITEM | DESCRIPTION | QTY |
| A | HEADBOARD | 1 PC |
| B | FOOTBOARD | 1 PC |
| C | SIDE RAIL | 2 PCS |
| D | CENTER RAIL | 1 PC |
| E | CENTER SUPPORT LEG | 3 PCS |
| F | CENTER SUPPORT | 2 PCS |
| G | BED SLAT | 24 PCS |
| H | BED LEG | 4 PCS |

| HARDWARE LIST | | |
|---------------|---------------------------|--------|
| ITEM | DESCRIPTION | QTY |
| 1 | WOOD SCREW M4 x 20mm | 2 PCS |
| 2 | WOOD SCREW M3.5 x 16mm | 8 PCS |
| 3 | PVC BLACK WASHER | 4 PCS |
| 4 | BED SLAT SIDE FITTER | 24 PCS |
| 5 | BED SLAT CENTRE FITTER | 12 PCS |
| 6 | M5 ALLEN KEY (BALL SHAPE) | 1 PC |

STEP 1

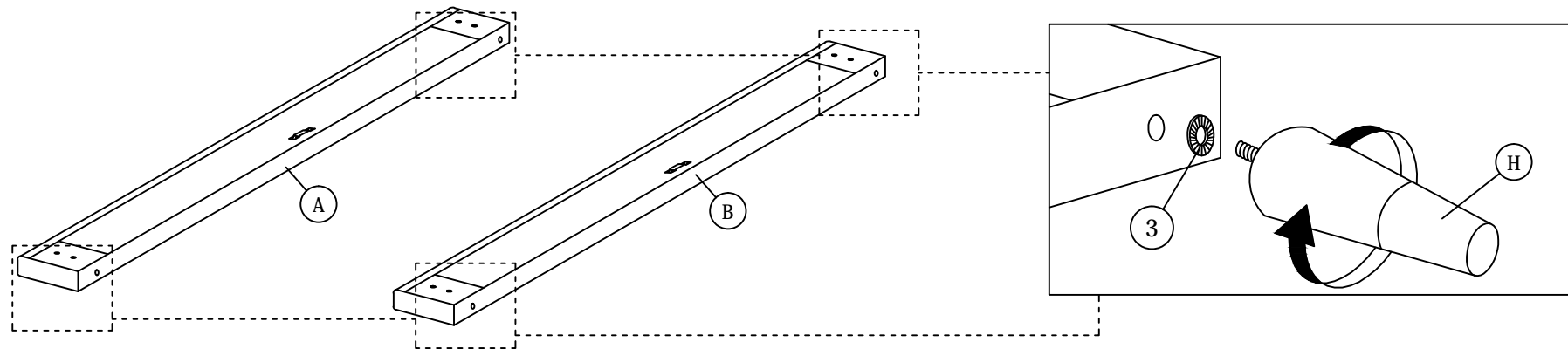

STEP 2

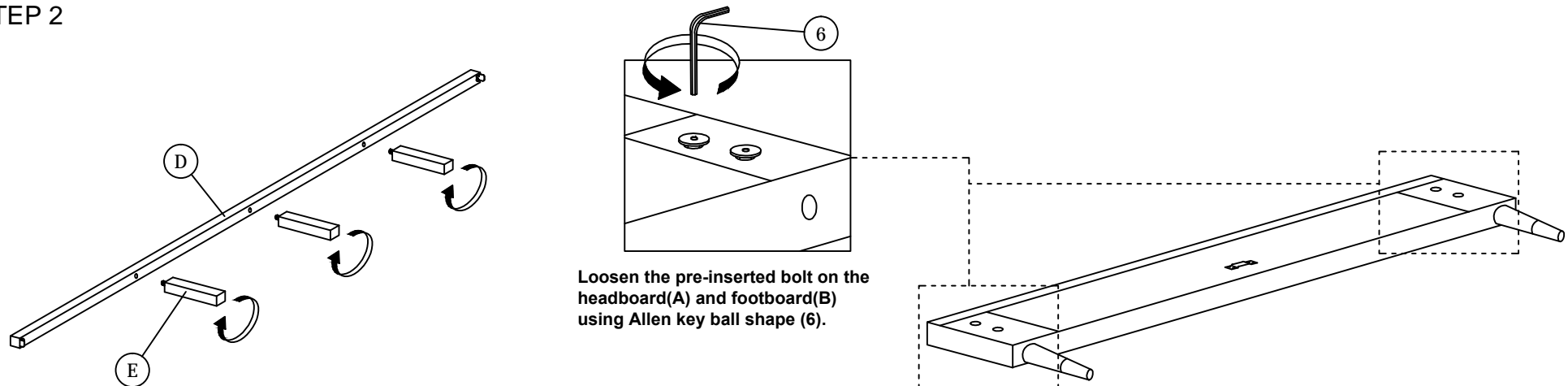

ASSEMBLY INSTRUCTIONS

STEP 3

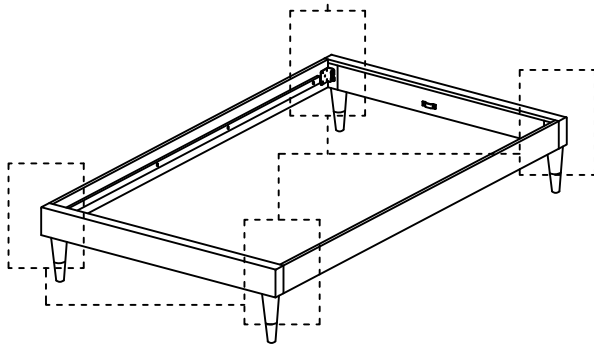
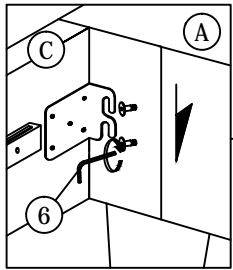

STEP 4

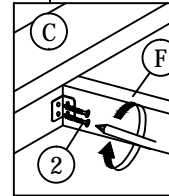
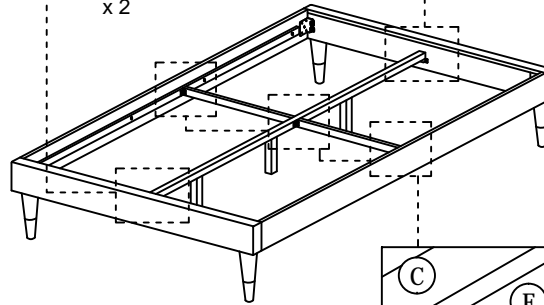
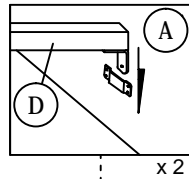

STEP 5

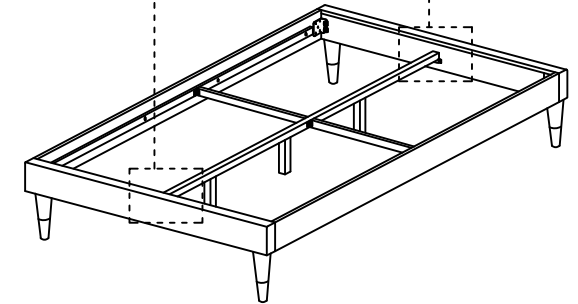
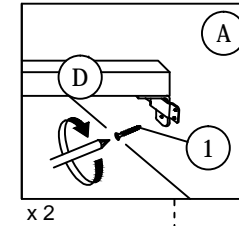

STEP 6

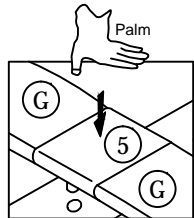
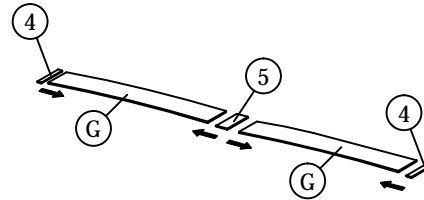
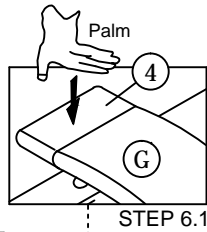

STEP 6.2

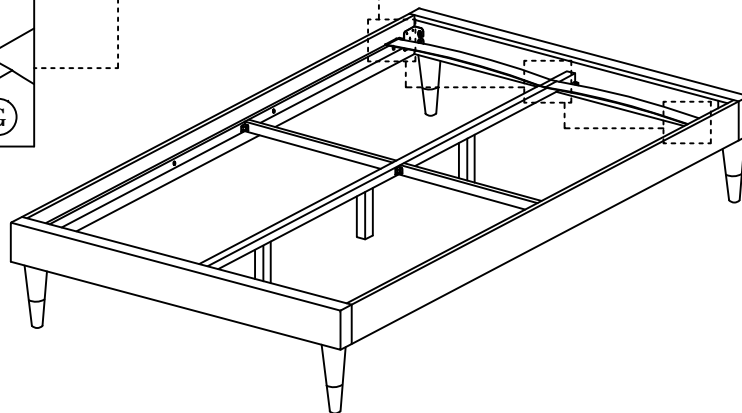

STEP 7

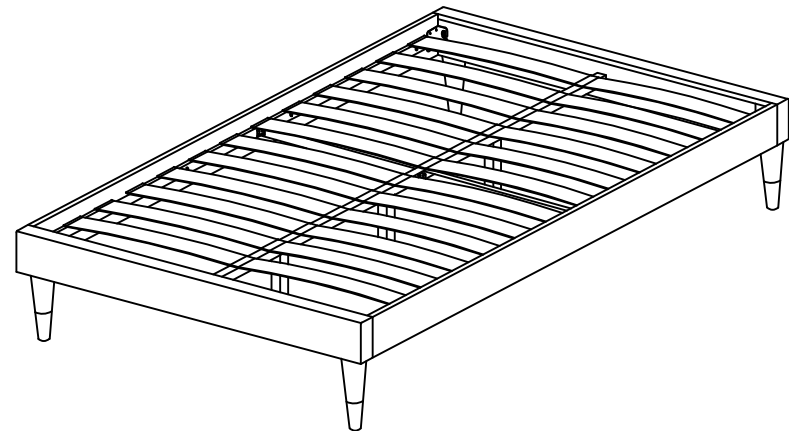

* When moving the bed position, the center support legs must be adjust to be straight to avoid any broken problem.