

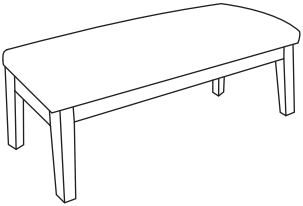





PARTS LIST



NO	DESCRIPTION		QTY
A	Bench Seat		1
B	Bench Leg		4
C	Screw	$\Phi 5/16'' * 2-3/4'' L$ 	8
D	Flat Washer	$\Phi 5/16'' * 22mm$ 	8
E	Lock Washer	$\Phi 5/16''$ 	8
F	Allen Wrench	$\Phi 5mm$ 	1

STEP

Note:

1. Check the PART LIST and HARDWARE LIST.
2. Install the four bench legs according to the installation drawing.

