

Upholstered bed

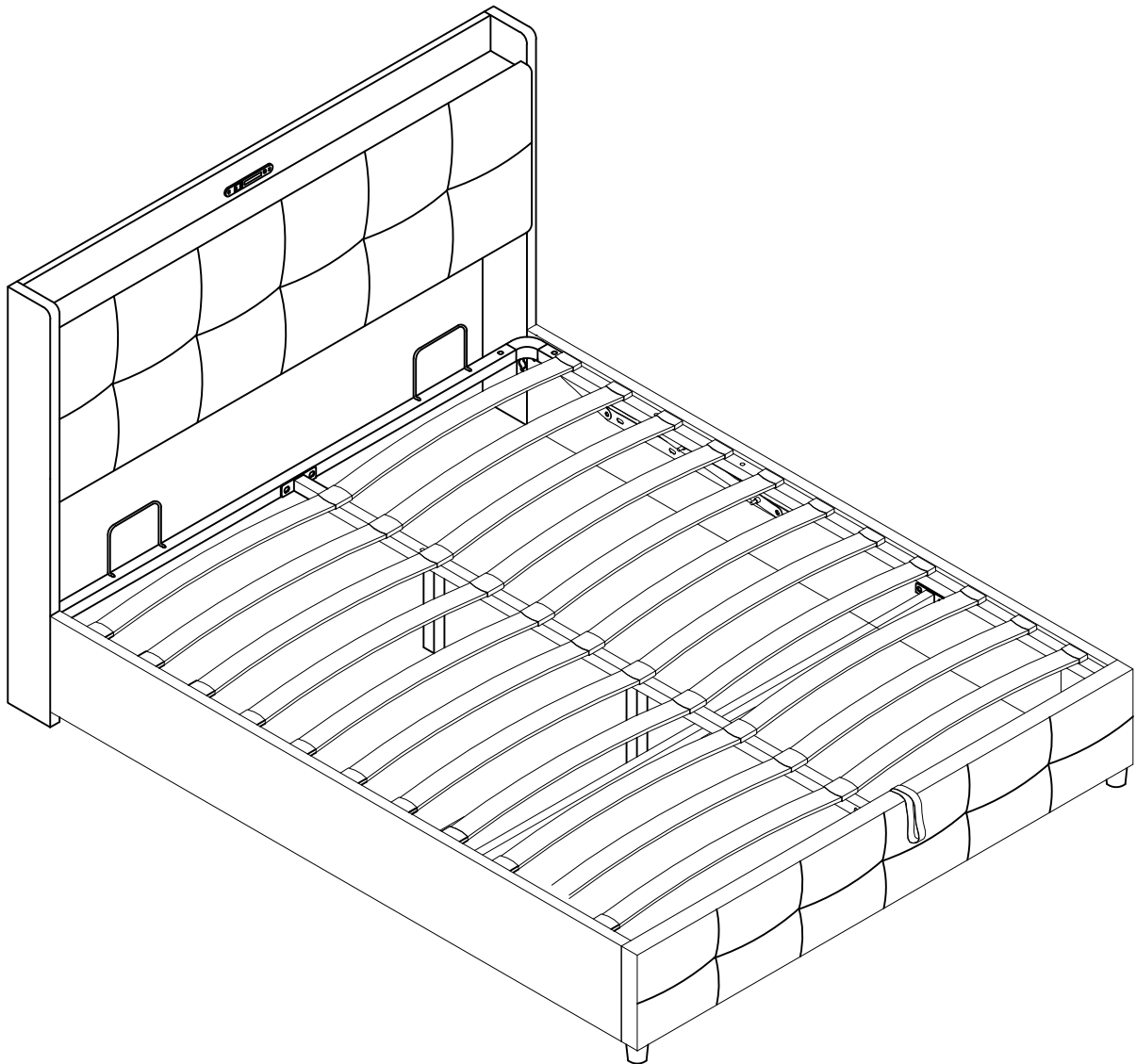

N652P257468 N652P257469



TIPS

1. This product is divided into 2 parcels for delivery. They may not arrive at the same time. Please wait patiently.
2. Please read the instructions fully before assembly. These instructions include important information which could ensure correct assembly. We have been working on providing high quality products for you. However, in the rare instance that your product is defective, missing parts or there are some issues, please don't hesitate to contact our customer service to submit parts requirements, assembly suggestion, or warranty claims, and we will give the best solution as soon as possible. If necessary, we need you to provide some more clear pictures of the issue.
3. Insert the screws in holes and tighten the screws, but not too tight, 70%~80% is ok, finally tighten all the screws. If some issues happened that some screws can not target to the hole or some parts are difficult to install, please adjust the tightness of the screws.
4. 2 people are recommended to finish.

N652P257469

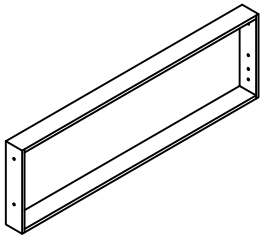

1
X1

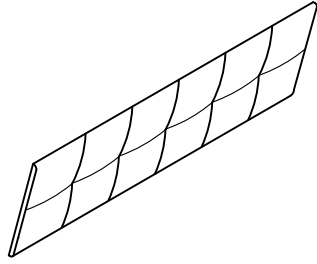

3
X1



10
X2



11
X2

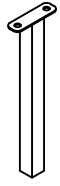

12
X2



13
X1



14
X1

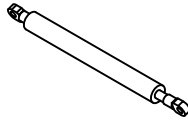

15
X2



16
X1



17
X1

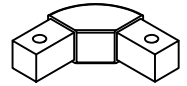

18
X4

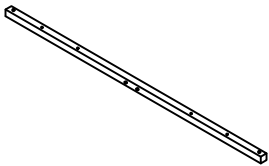

20
X2

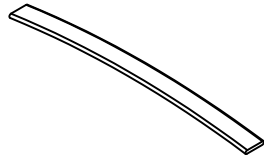

22
X22



23
X2

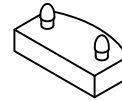

24
X24

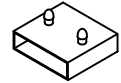

25
X12

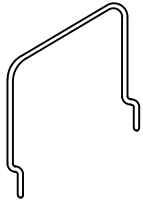

26
X2

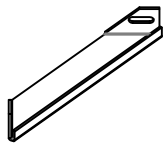

29
X2

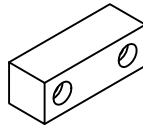

30
X1

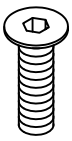

A
M8*15
X14+2

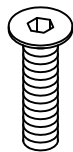

B
M8*20
X44+6

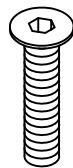

C
M8*30
X3+1

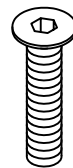

D
M8*35
X4+1



E
M8*Ø22
X7+1

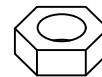

F
M8
X4+1



G
X1



H
M5
X1

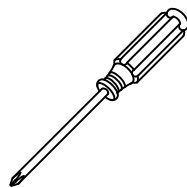

I
X1

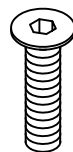

J
M6*20
X4+1

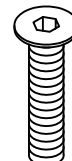

K
M8*50
X2+1

N652P257468

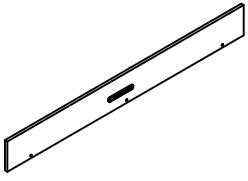

2
X1

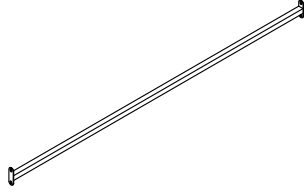

4
X1



5
X1



6
X1

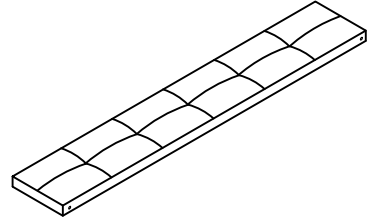

7
X1

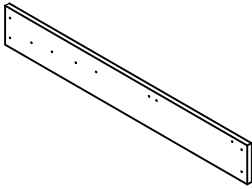

8
X1

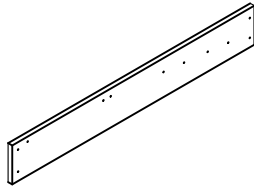

9
X1

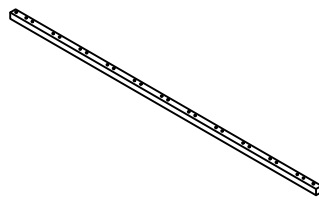

19
X2

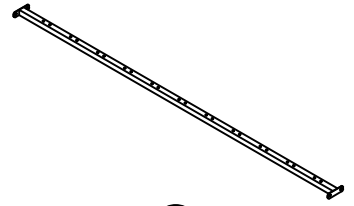

21
X1



27
X1

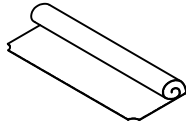

28
X1

Upholstered bed

OVERVIEW

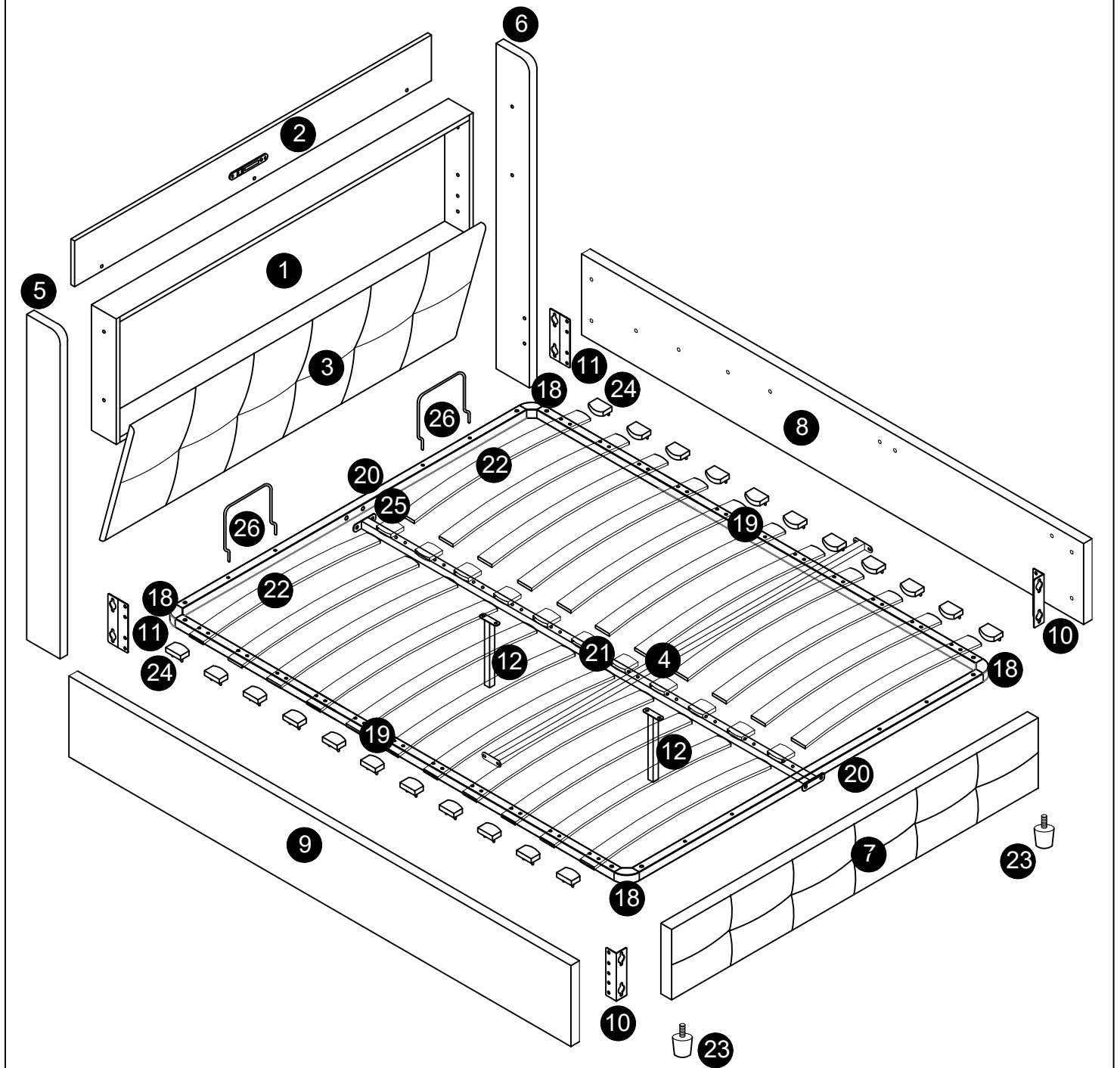

Upholstered bed

1

Tip: Please pay attention to the orientation of the night light

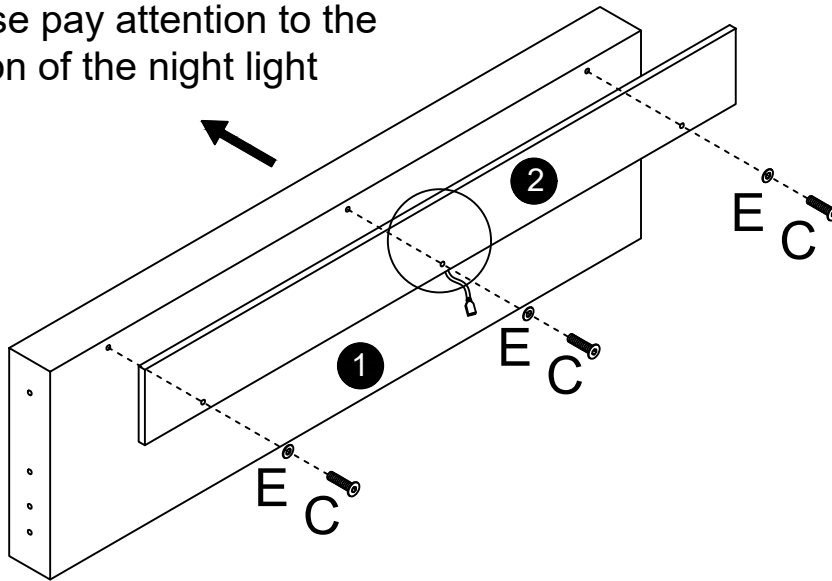

C M8*30
 X3

E M8*Ø22
 X3

2

Long press the button on the night light to adjust the brightness

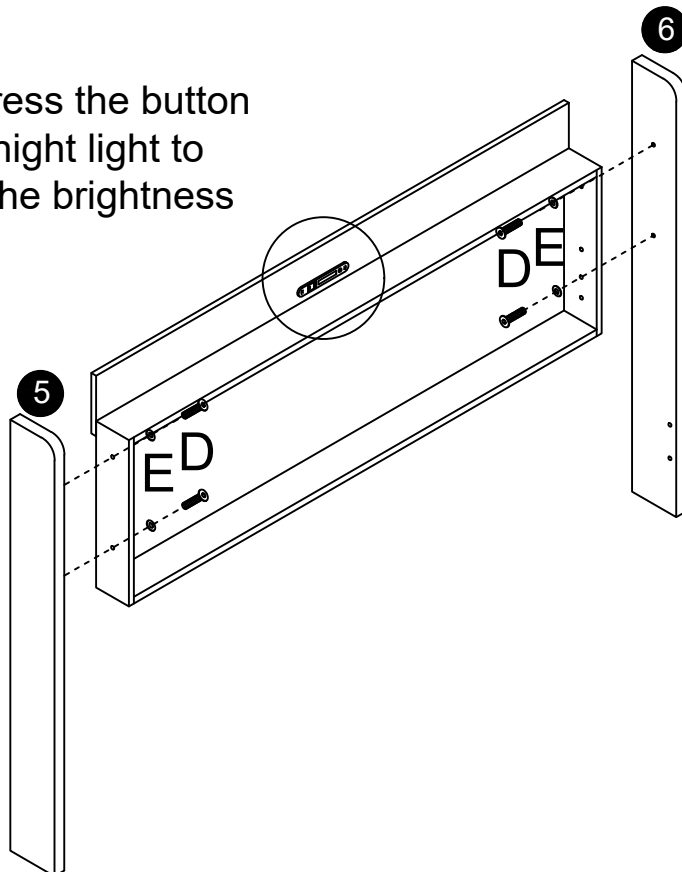

D M8*35
 X4

E M8*Ø22
 X4

Upholstered bed

3

A M8*15
 X4

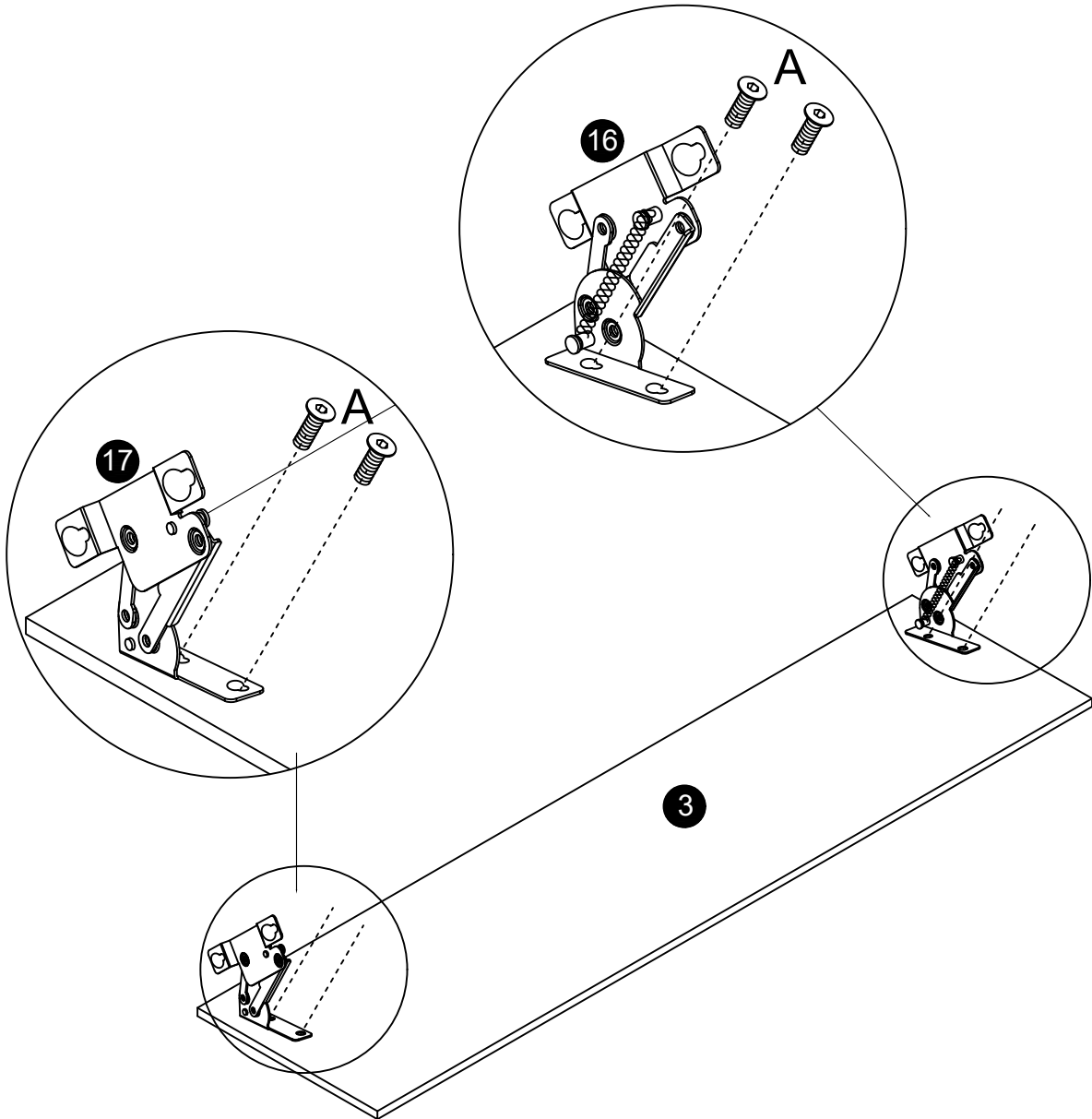

Upholstered bed

4

A M8*15
 X4

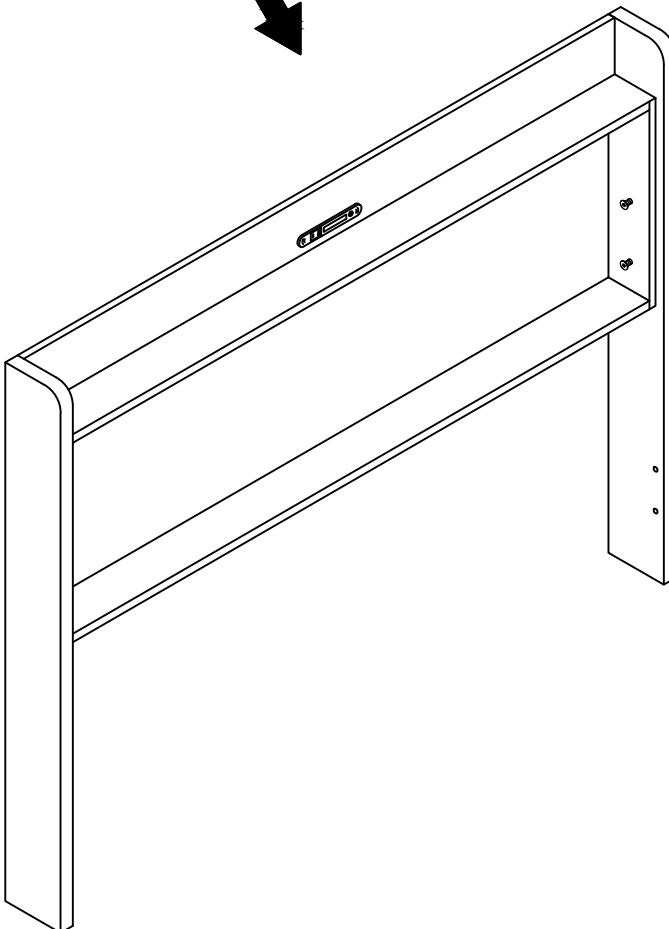
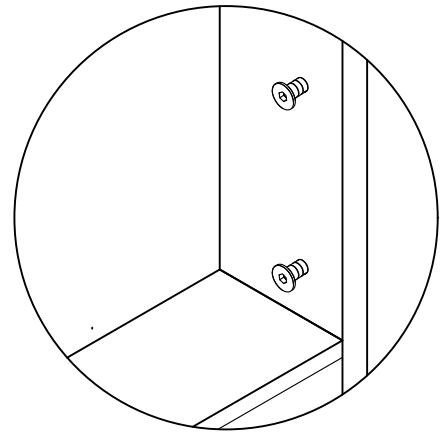
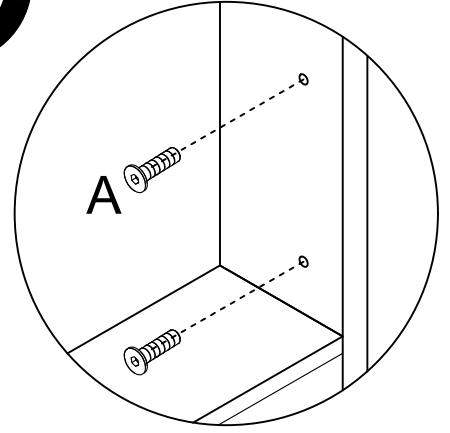
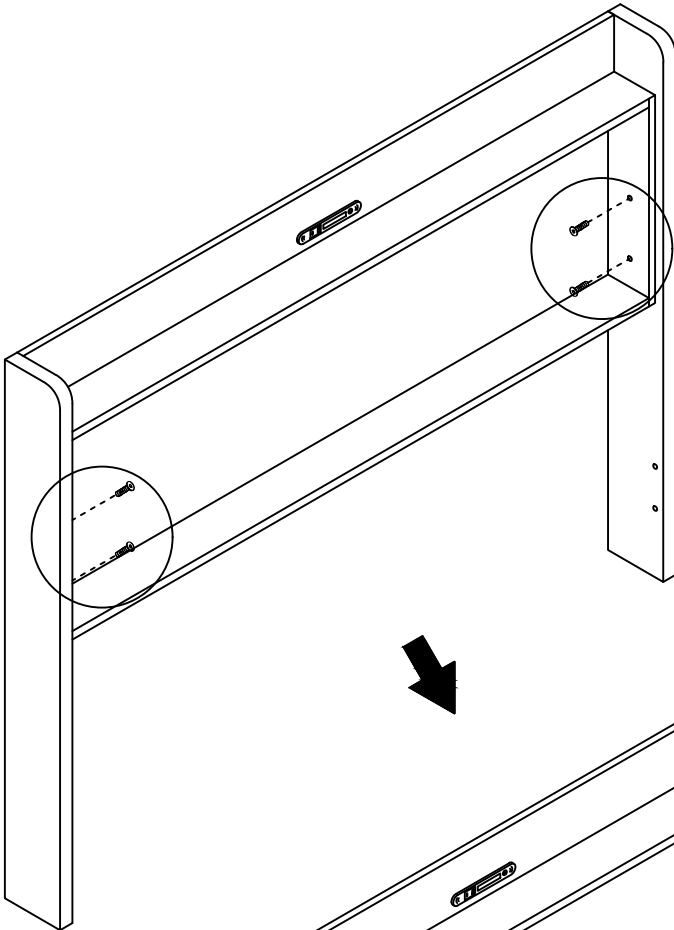

Upholstered bed

5

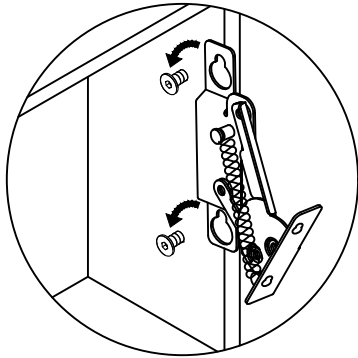

Hang it up first

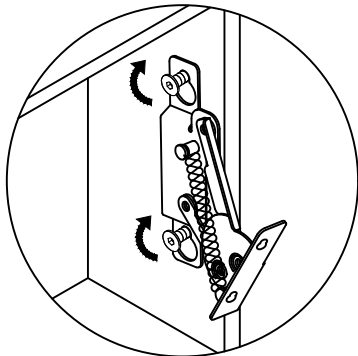

Then tighten it

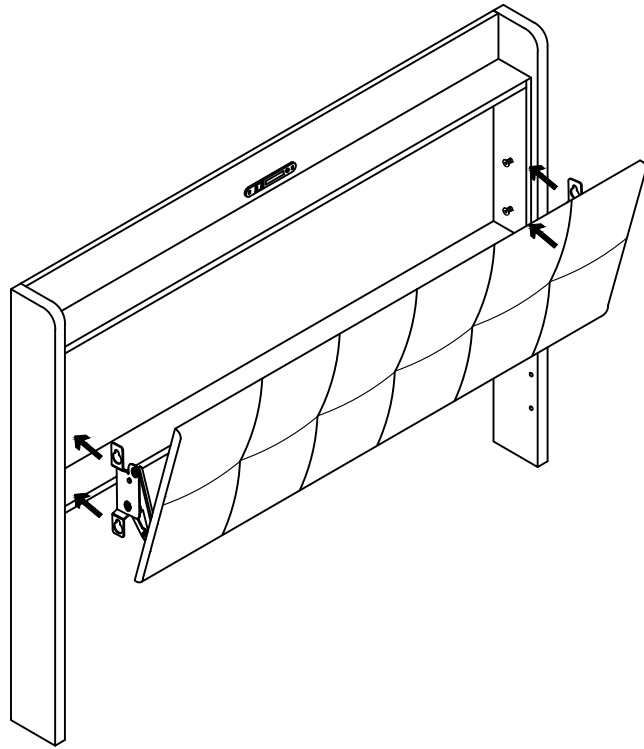

6

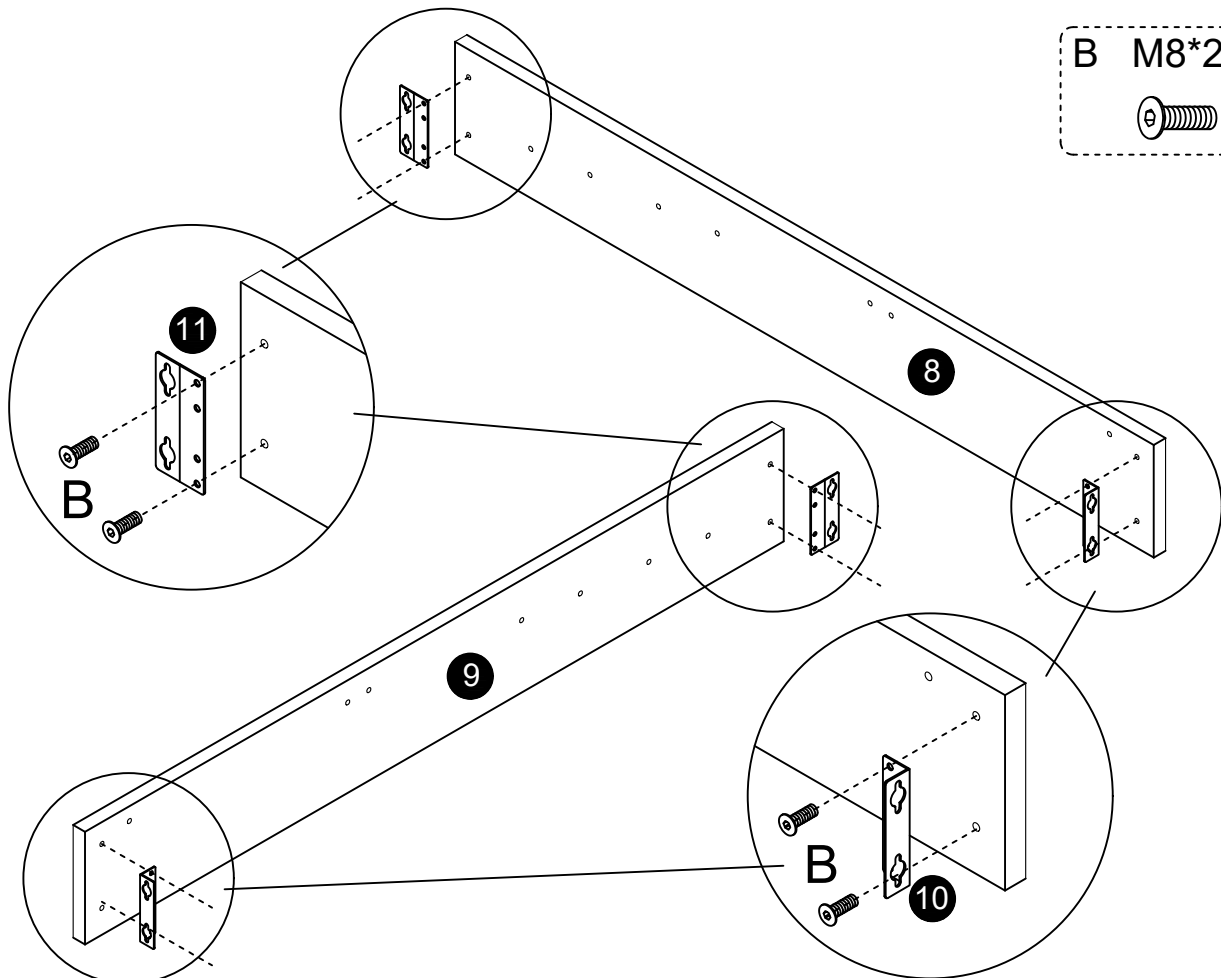

B M8*20
X8

Upholstered bed

7

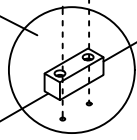
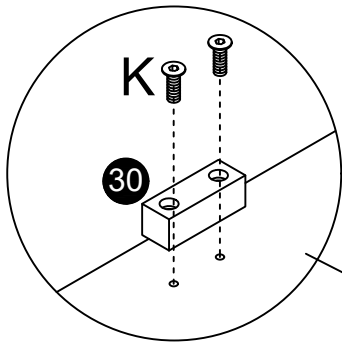

7

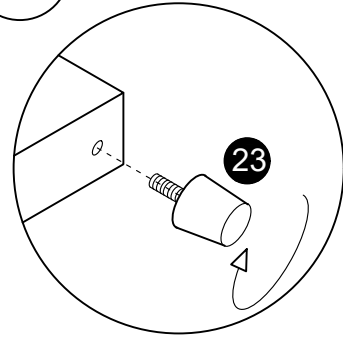
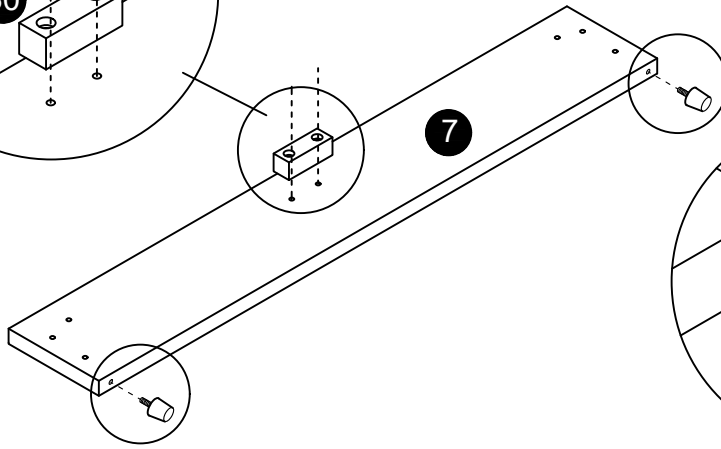

B M8*20



X8

K M8*50



X2

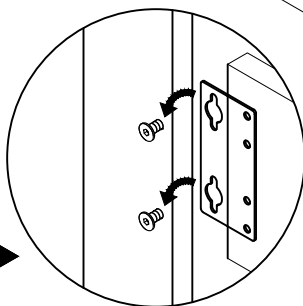
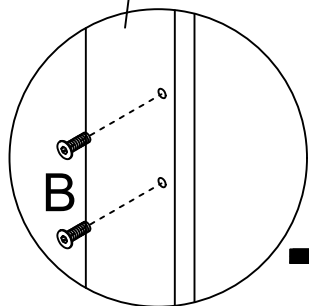
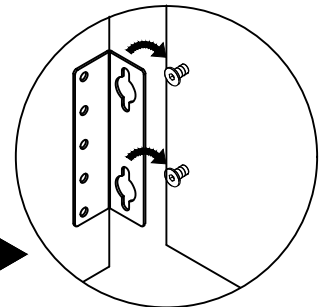
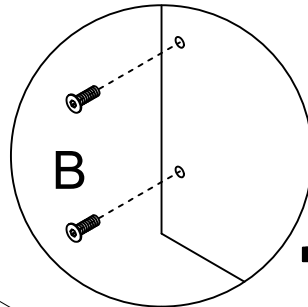
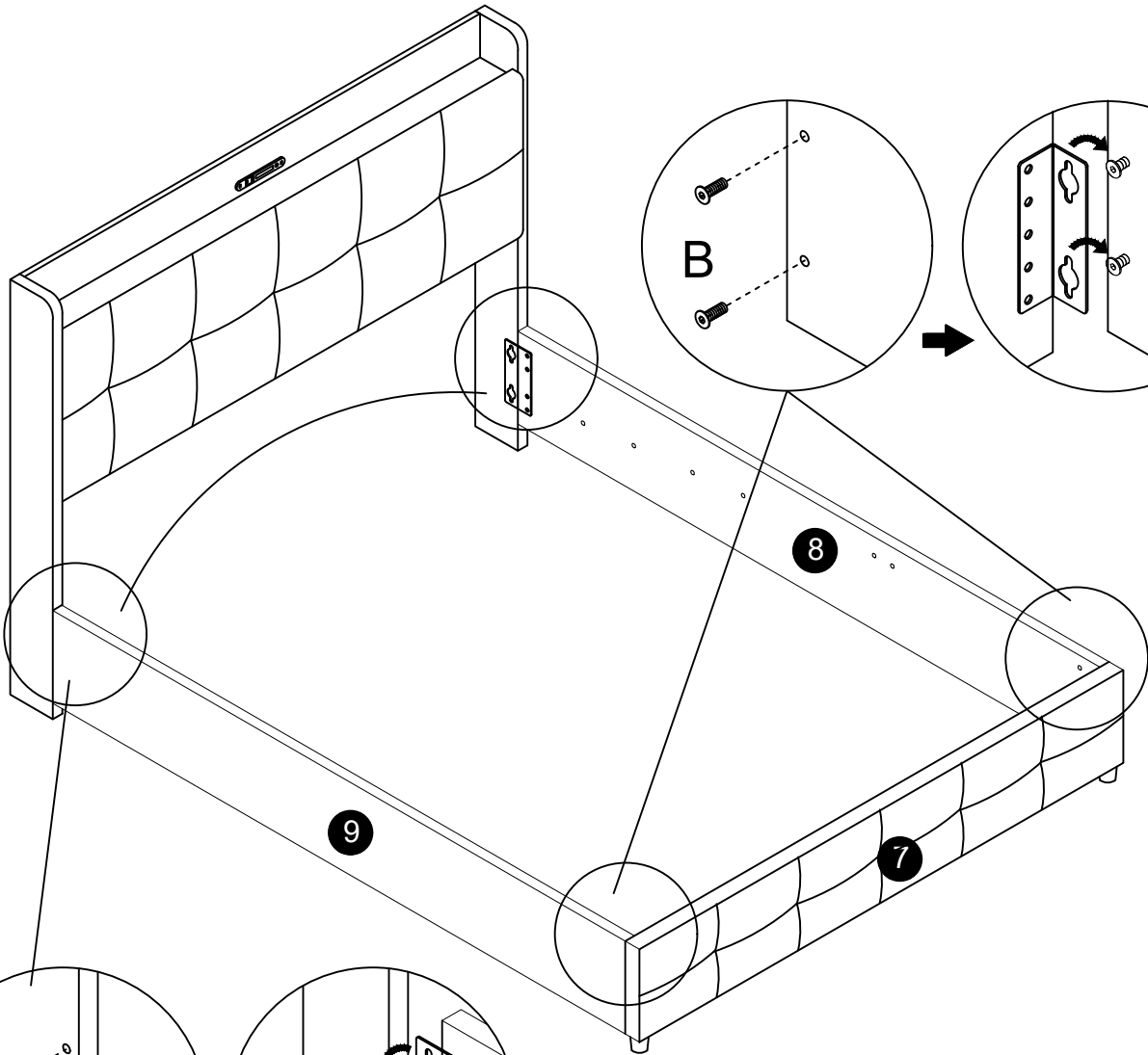

Upholstered bed

8

J M6*20

 X4

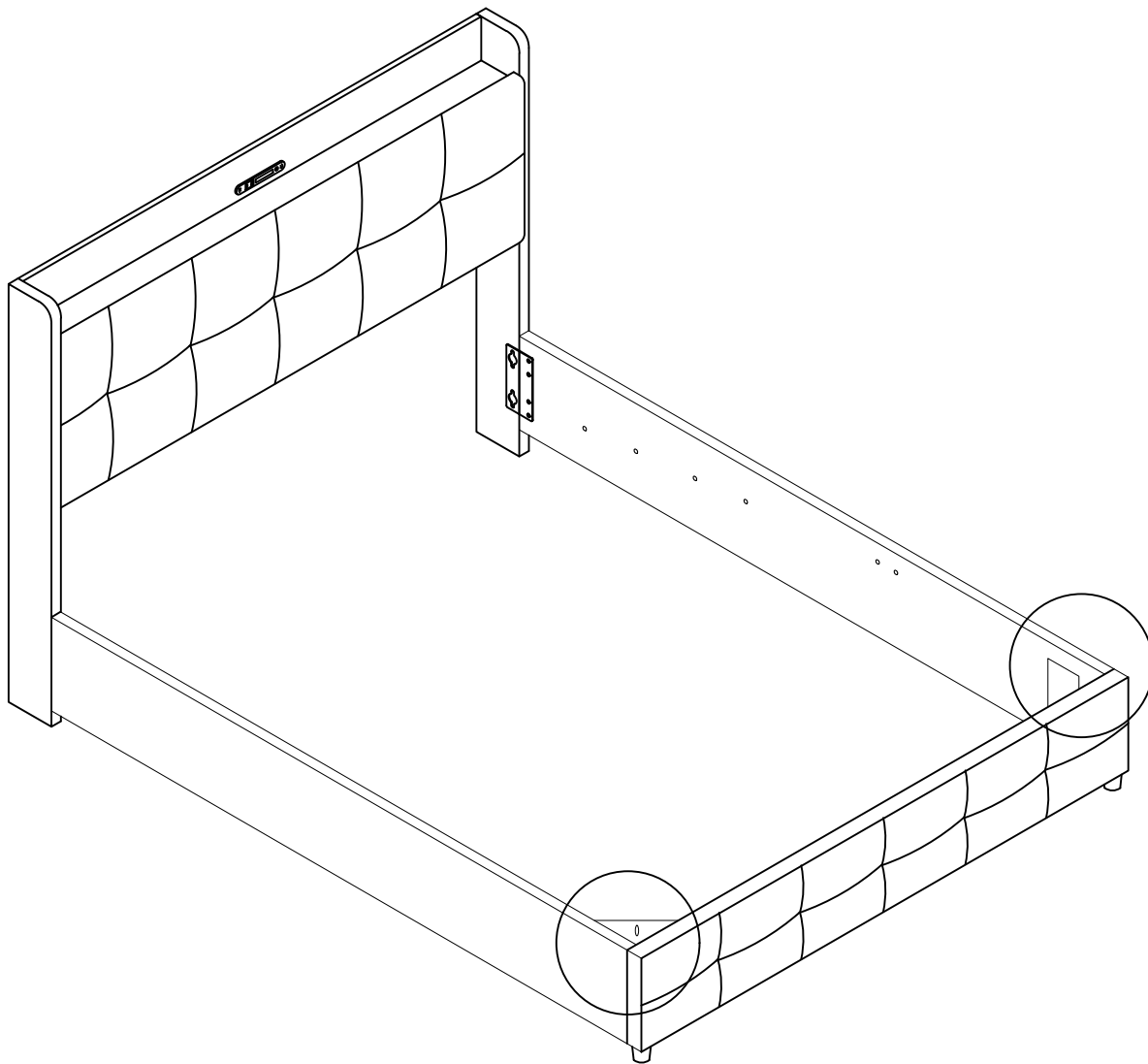
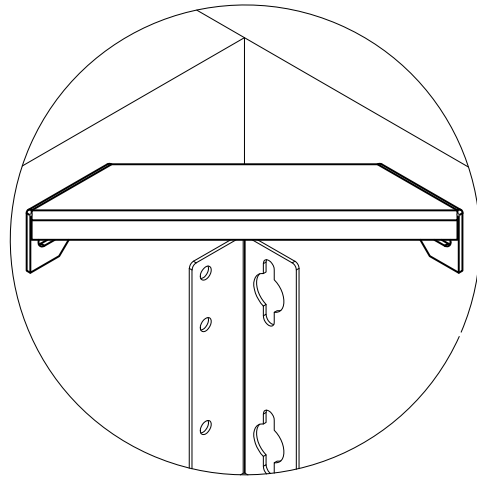
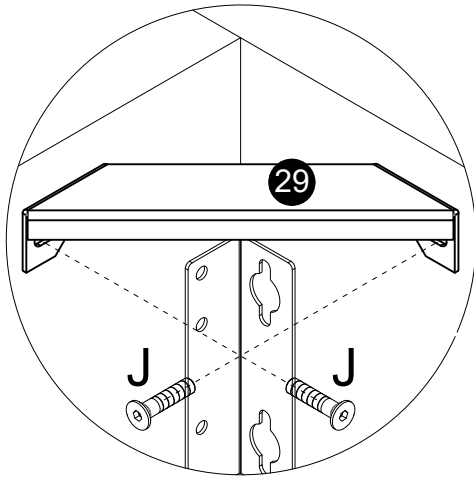

Upholstered bed

9

B M8*20
 X8

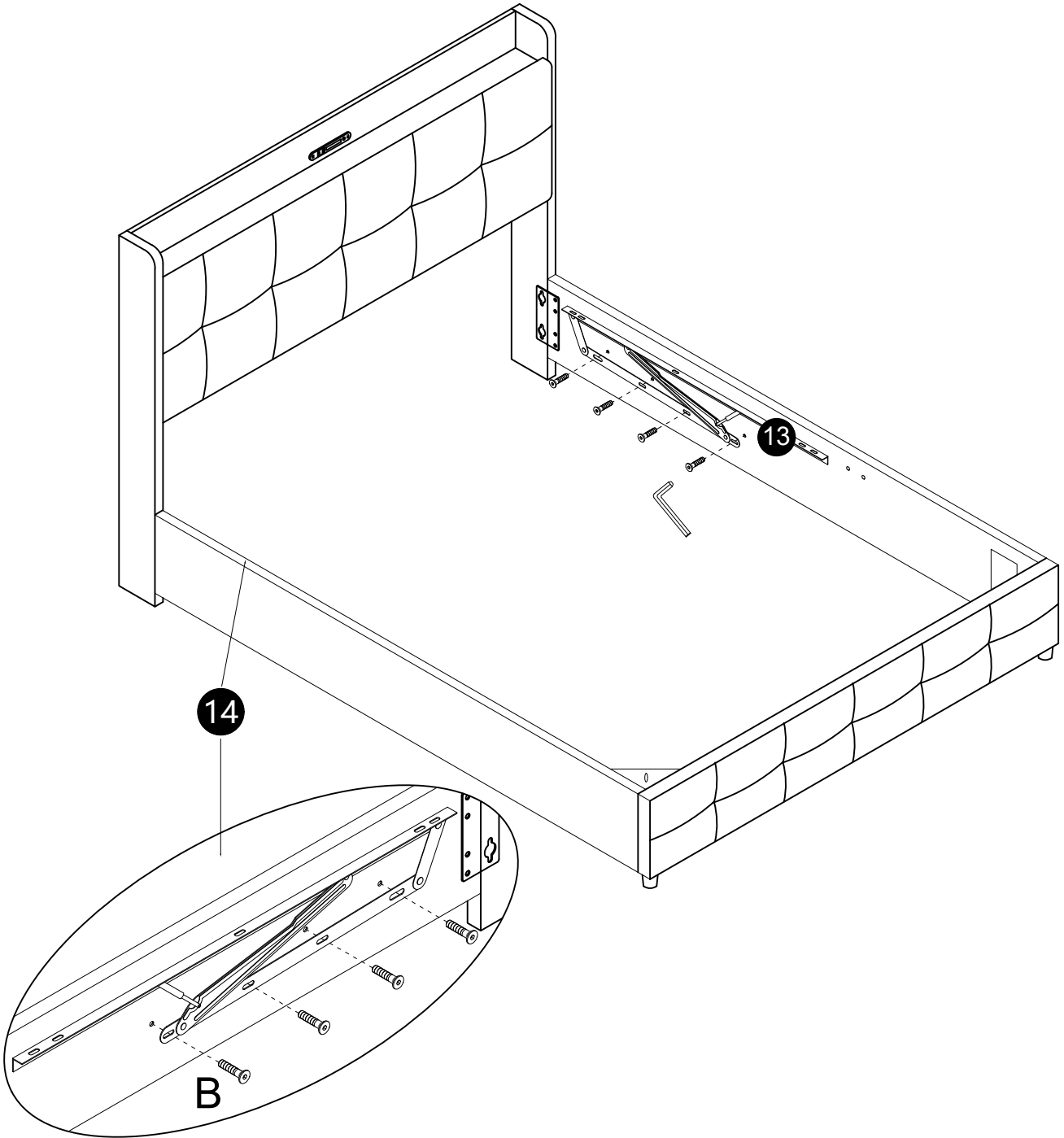

Upholstered bed

10

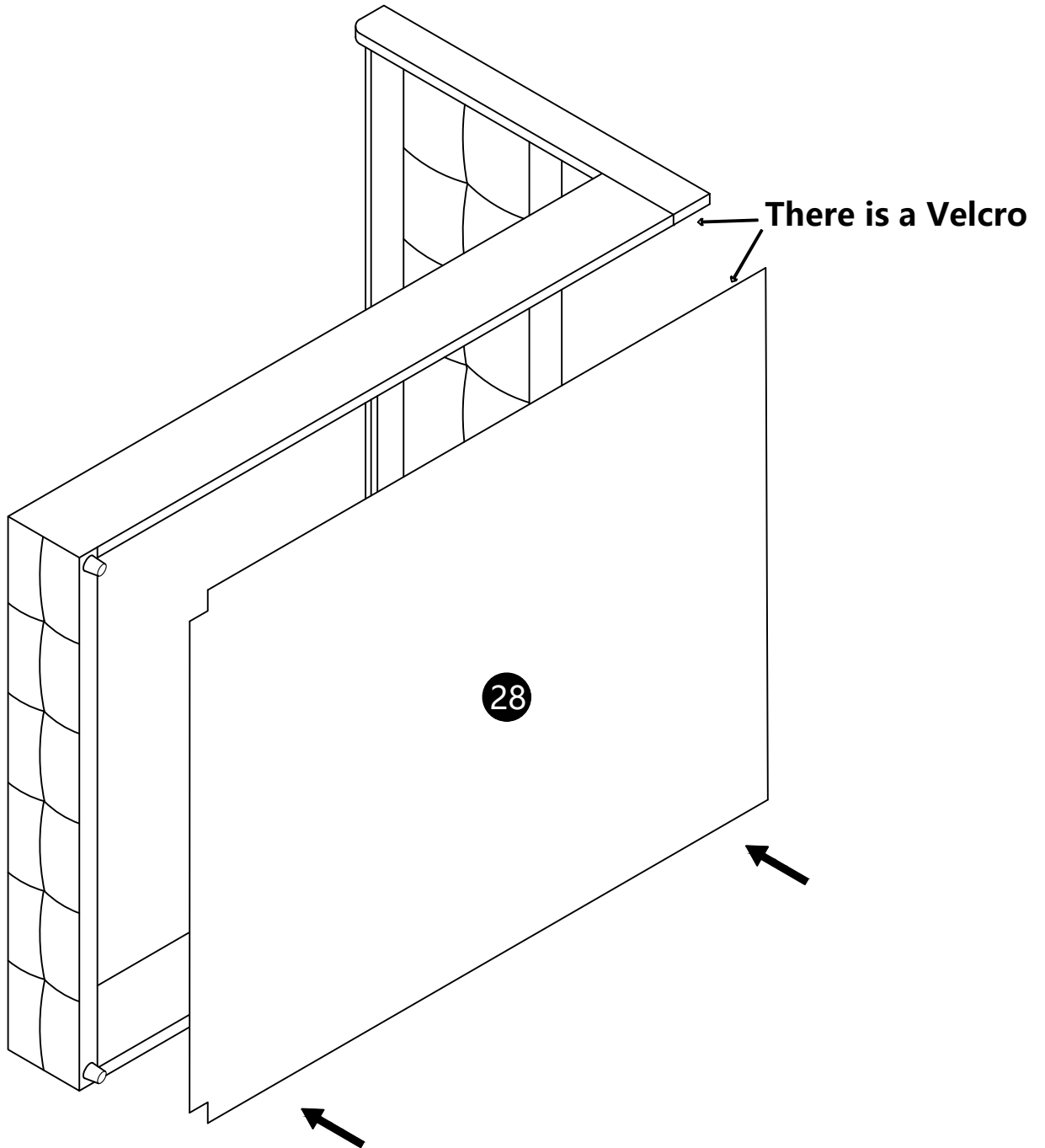

Upholstered bed

11

B M8*20

 X4

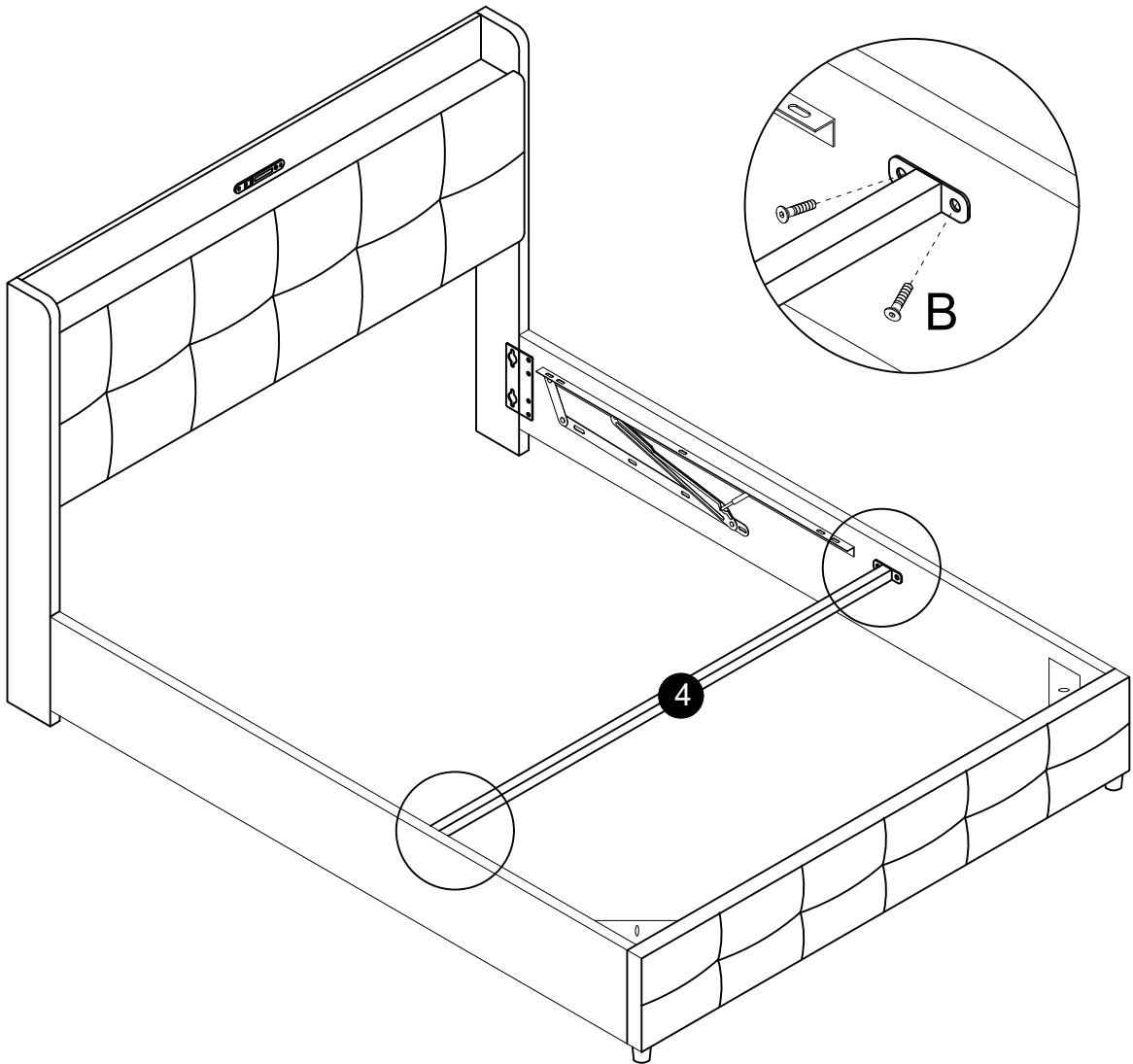

Upholstered bed

12

A M8*15
 X8

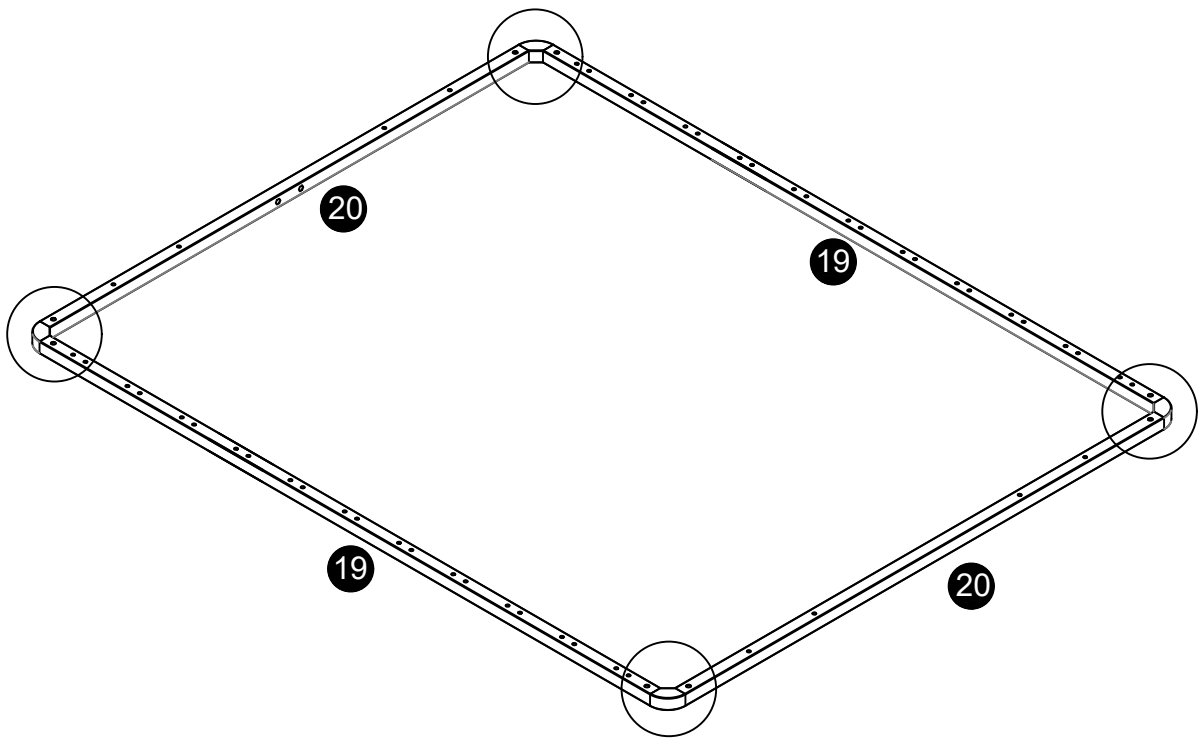
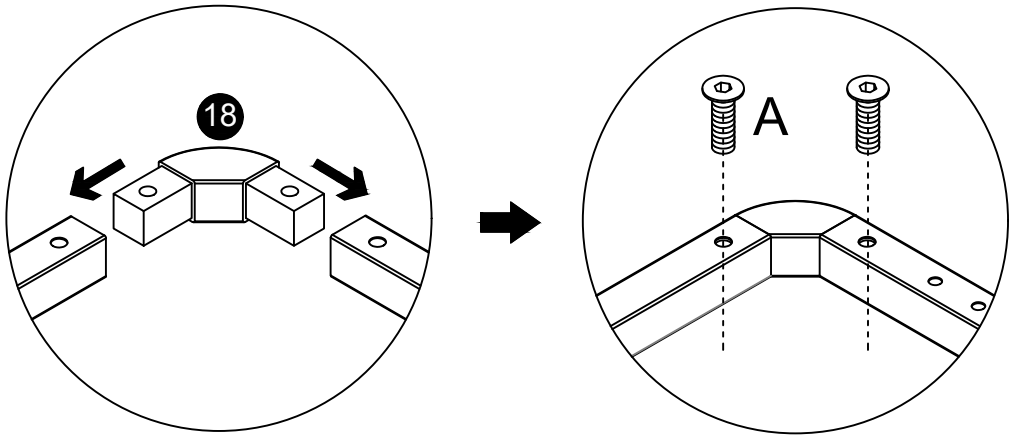

Upholstered bed

13

B M8*20
X8

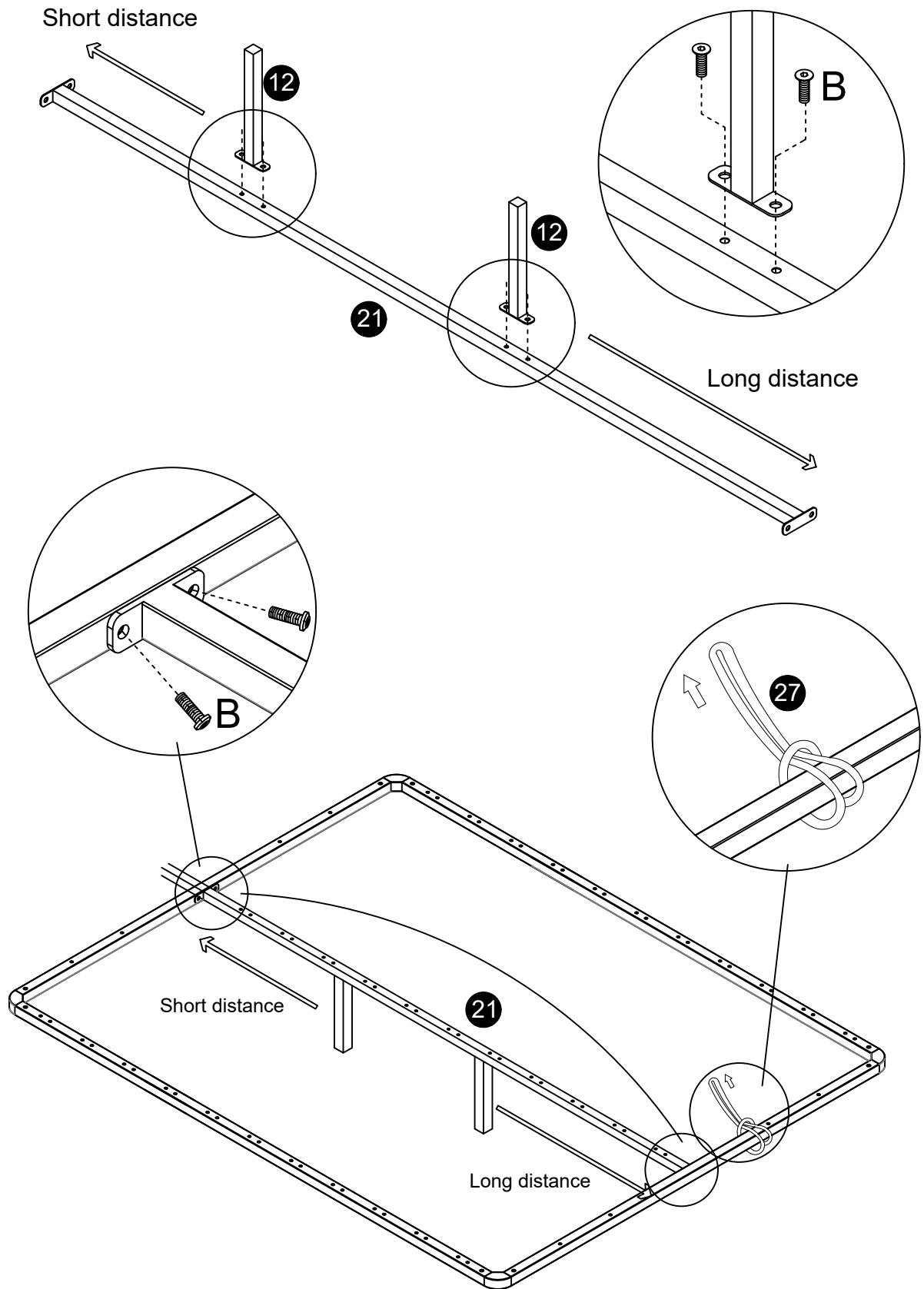

Upholstered bed

14

B M8*20

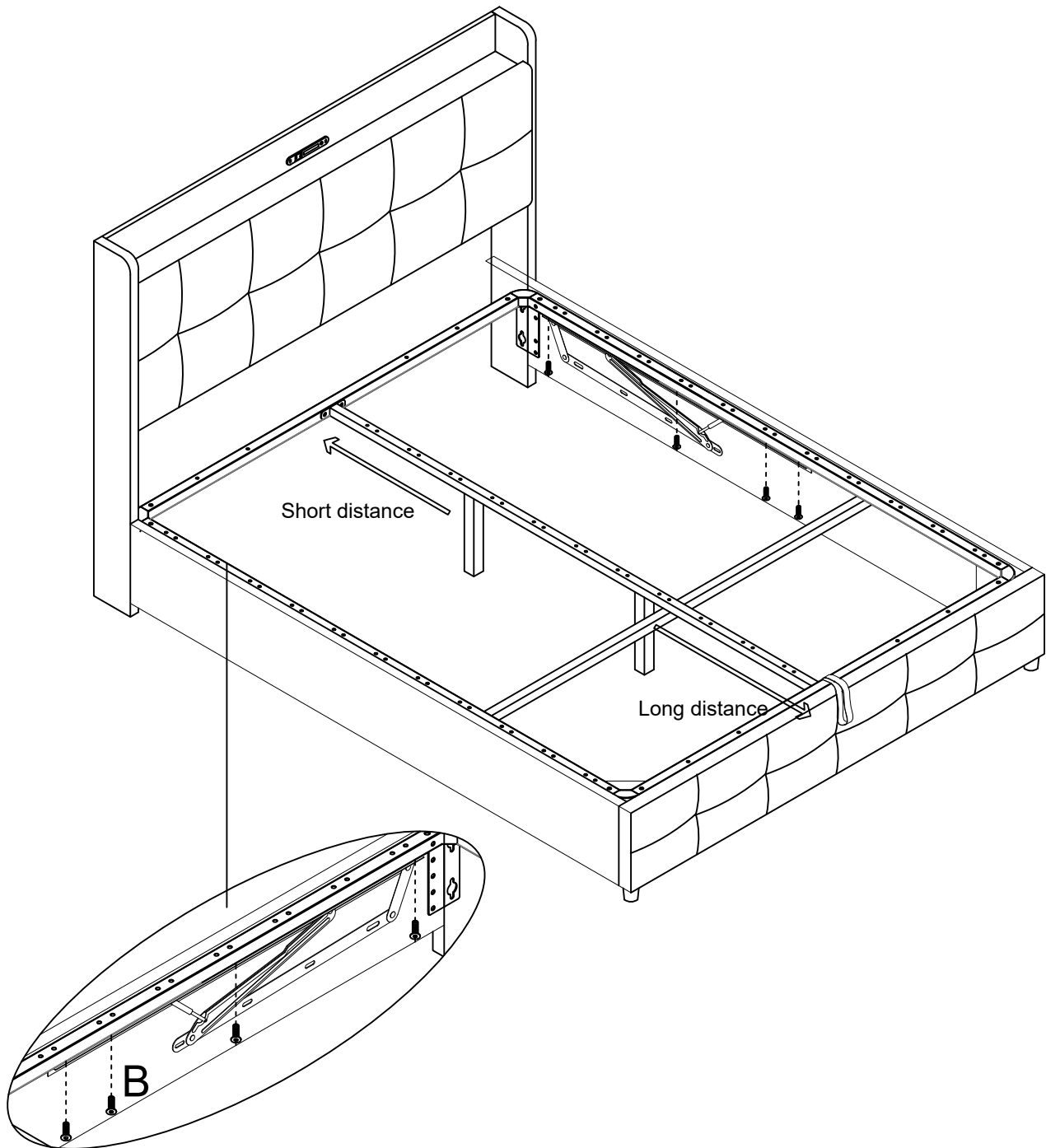

Upholstered bed

15

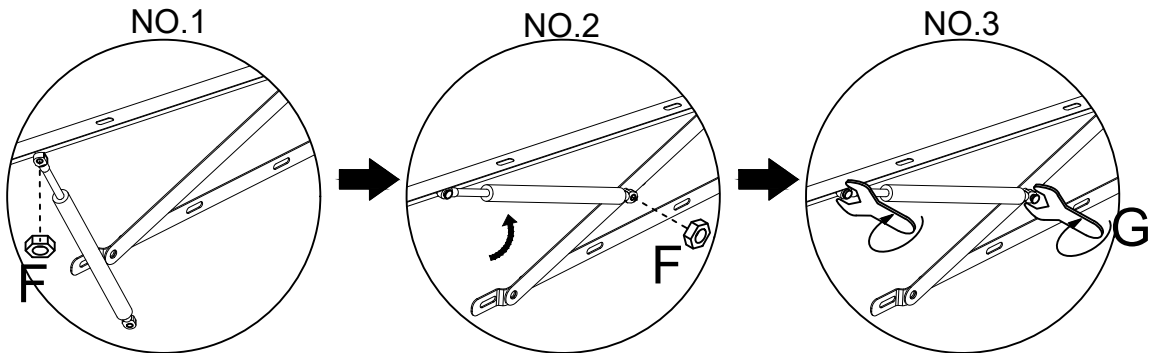
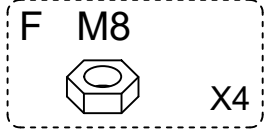

One person lifts the bed frame, while the other locks the nut

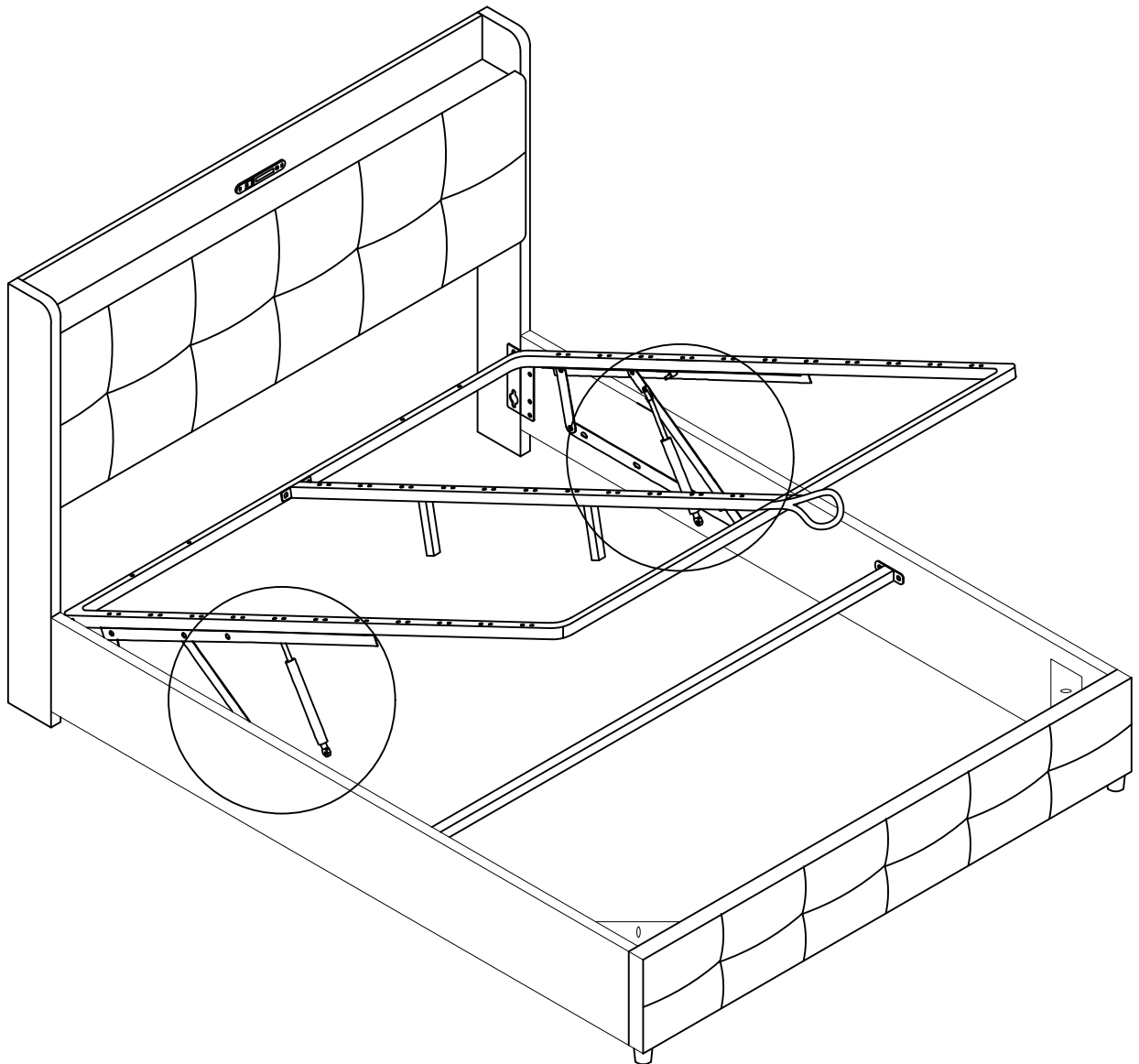

Upholstered bed

16

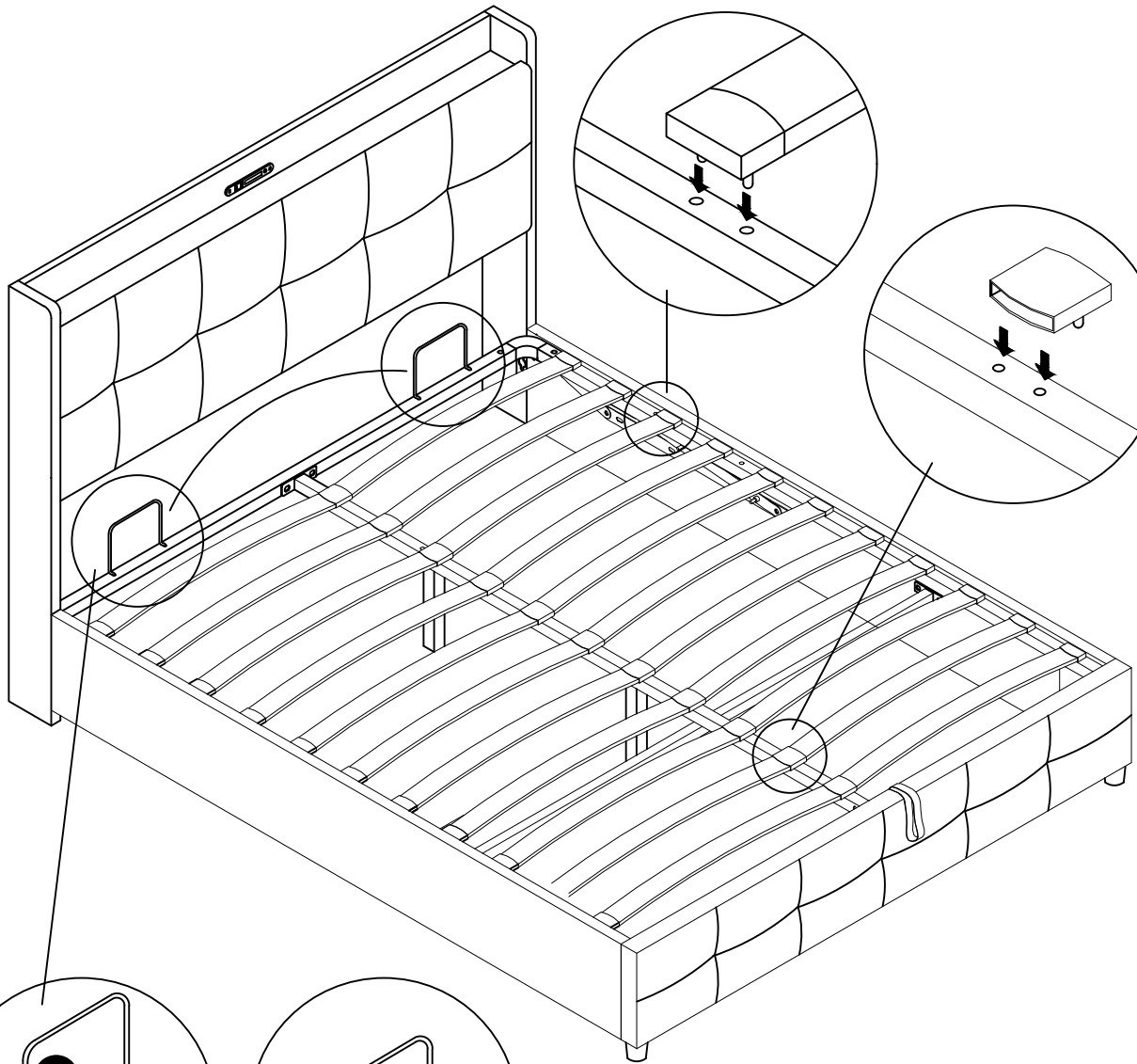
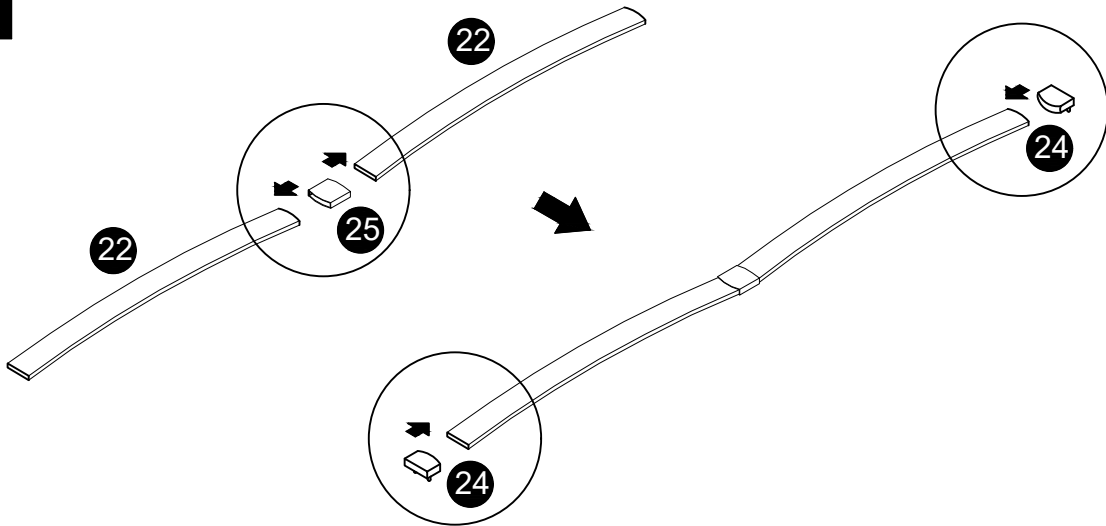



Certificate No.: CBT240425023EC

Certificate of Conformity

Applicant : Guangdong Jishengke Industrial Co.,Ltd
Room 202, No. 10, Xin'an Hengtai Road, Chang'an Town, Dongguan City, Guangdong Province

Manufacturer : Guangdong Jishengke Industrial Co.,Ltd
Room 202, No. 10, Xin'an Hengtai Road, Chang'an Town, Dongguan City, Guangdong Province

Product : String Light

Model(s) : JSK-L20
JSK-L21,JSK-L22,JSK-L23,JSK-L24

Trademark : N/A

Test Standard : EN IEC 55015:2019+A11:2020
EN 61547:2009
EN IEC 61000-3-2:2019+A1:2021
EN 61000-3-3:2013+A2:2021

The Certificate of Conformity is based on an evaluation of a sample of the above mentioned products. It does not imply an assessment of the whole production. It is possible to use CE marking to demonstrate the compliance with this EMC Directive 2014/30/EU. It is only valid in connection with the test report number: CBT240425023ER



Shenzhen CABLETEK Compliance Laboratory Limited
East 02, 6th Floor, Building 3, Zhouteng Industrial Zone, Shanglilang Community, Nanwan Street, Longgang District, Shenzhen

Tel: 400 666 1146

E-mail: cbt@cabletek.cn

Web: www.cabletek.cn