

## ASSEMBLY INSTRUCTIONS 24" CROSSBACK STOOL ITEM

ASSEMBLY  
REQUIREMENTS

1-PERSON  
ASSEMBLY

30 MINUTES  
ASSEMBLY TIME  
PER STOOL  
(APPROXIMATE)

TOOLS REQUIRED  
(NOT PROVIDED)

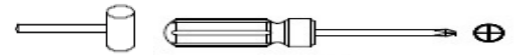

MALLET

PHILLIPS SCREWDRIVER

### Thank you for purchasing our product!

Please refer and use this assembly instruction to assemble the product.

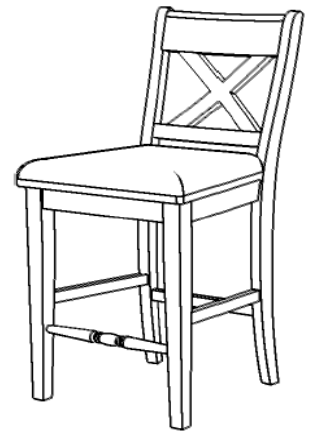

**We appreciate your business!**

### ASSEMBLY PREPARATION

1. Remove all packing materials, staples and packing straps from the carton.
2. Refer to Parts List and Hardware List, and ensure all the parts and hardware are correct before assembly.
3. Place all wooden parts on a clean, flat and soft surface (e.g. carpet or rug) to prevent parts from getting scratched.

### SAFETY PRECAUTION

1. KEEP ALL HARDWARE PARTS OUT OF REACH OF CHILDREN.
2. DISPOSE PLASTIC PACKAGING MATERIAL IMMEDIATELY TO AVOID ANY RISK OF SUFFOCATION TO CHILDREN AND ANIMALS.

### TIPS FOR ASSEMBLY

1. Allow ample room for assembly and in close proximity to where product will be placed.
2. Assemble the product on a surface that does not scratch or damage the exterior gloss and finish of the furniture.
3. Identify all of the parts, hardware and quantities required for each step.
4. During assembly, do not over-tighten any fittings as this may cause damage.
5. DO NOT USE POWER TOOLS TO ASSEMBLE THIS PRODUCT.
6. Always place the product on a flat, level surface.
7. Do not sit or stand on the partially assembled product; only use the product for which it is intended.

### CARE AND MAINTANANCE



- Use a slightly damp cloth to clean the product. Do not use bleach or abrasive cleaning material.
- Check all the fittings periodically and re-tighten as necessary. Do not use the product if any of the parts is damaged or broken.
- Never allow any kind of liquid to remain on your furniture. Absorption can cause wood to warp or delaminate.
- Do not place hot items (e.g. hot drinks) directly onto the wood surface.
- Do not drag and/or pull the furniture.

This product is for indoor and household use only – not for commercial use.







# ASSEMBLY INSTRUCTIONS

## 24" CROSSBACK STOOL ITEM

### PART LIST (FOR 2 CHAIRS)

NO.	COMPONENT	QTY.
P1	CHAIR BACK	2
P2	CHAIR SEAT	2
P3	SIDE STRETCHER	2
P3	SIDE STRETCHER with sticker 	2
P4	FRONT STRETCHER	2
P5	FRONT LEG	2
P5	FRONT LEG with sticker 	2

### HARDWARE LIST (FOR 2 CHAIRS)

NO.	DESCRIPTION	QTY.	EXTRA
H1	JCBC SCREW M6 X 80 	16	1
H2	JCBC SCREW M6 X 35 	4	1
H3	SPRING WASHER 	20	2
H4	FLAT WASHER 	20	2
H5	ALLEN KEY 	1	
H6	CSK SCREW M4 X 38MM 	12	2
H7	LEG STUD 	8	2

\* Extra Hardware For Spare Use

### STEP 1

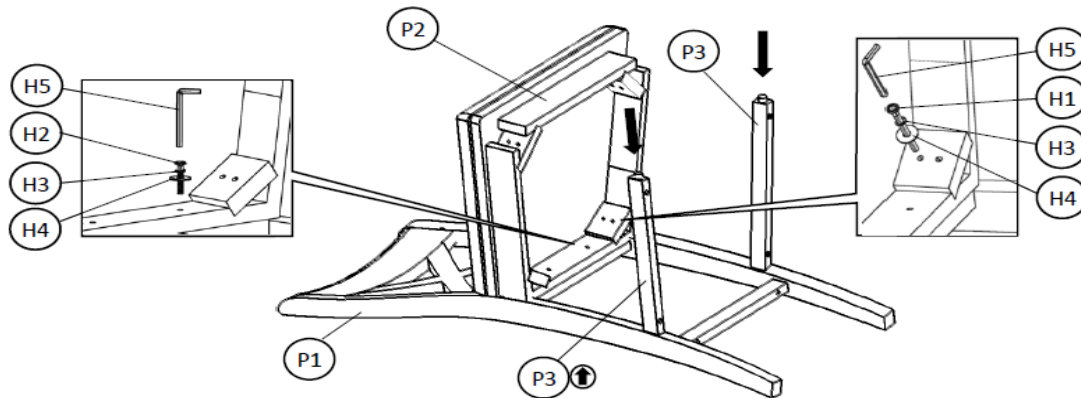

- Place Chair Back (P1) on a flat surface & soft material to prevent scratch and damage.
- Place Chair Seat (P2) on (P1) as shown. Fasten the two parts at the centre using JCBC Screw (H2) fitted with Spring Washer (H3) and Flat Washer (H4). Use Allen Key (H5) to drive (H2). Do not tighten (H2) completely at this time.
- At each rear corner of (P2), align the screw holes on the corner block to the screw holes on each rear leg. Next, insert Screw (H1) fitted with Spring Washer (H3) and Flat Washer (H4) into each of the screw hole. Use Allen Key (H5) to drive (H1). Do not tighten (H1) completely until all four screws are in place.
- Tighten Screw (H2) completely at this time.
- Insert Side Stretcher (P3) into the designated hole on (P1). Check that (P3) with  is on the right rear leg and the pocket screw holes on (P3) are facing the bottom end of (P1).

### STEP 2

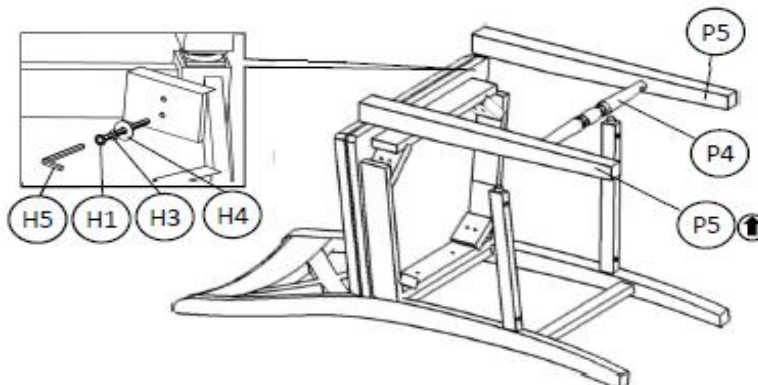

- Fit Front Stretcher (P4) between Front Legs (P5) as shown - note that P5 with  is the designated Right Front Leg.
- Attach the (P5 & P4) assembly above to the Side Stretchers .
- Align the screw holes on each Leg (P5) to the respective screw holes on the corner block at the front of Chair Seat. Next, insert Screw (H1) fitted with Spring Washer (H3) and Flat washer (H4) into each of the screw hole. Use Allen Key (H5) to drive (H1). Do not tighten (H1) completely until all four screws are in place on both Front legs.

## ASSEMBLY INSTRUCTIONS 24" CROSSBACK STOOL ITEM

### STEP 3

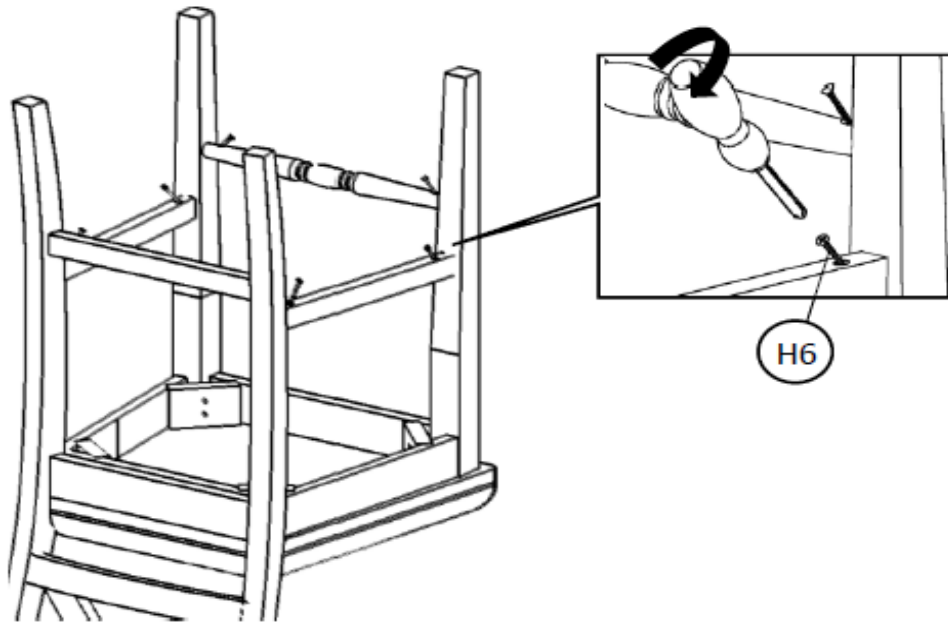

- Place the assembly from STEP 2, bottom-side up as shown on an elevated surface (e.g. table top).
- Use Screw (H6) to fasten Side and Front Stretcher to each Leg .

### STEP 4

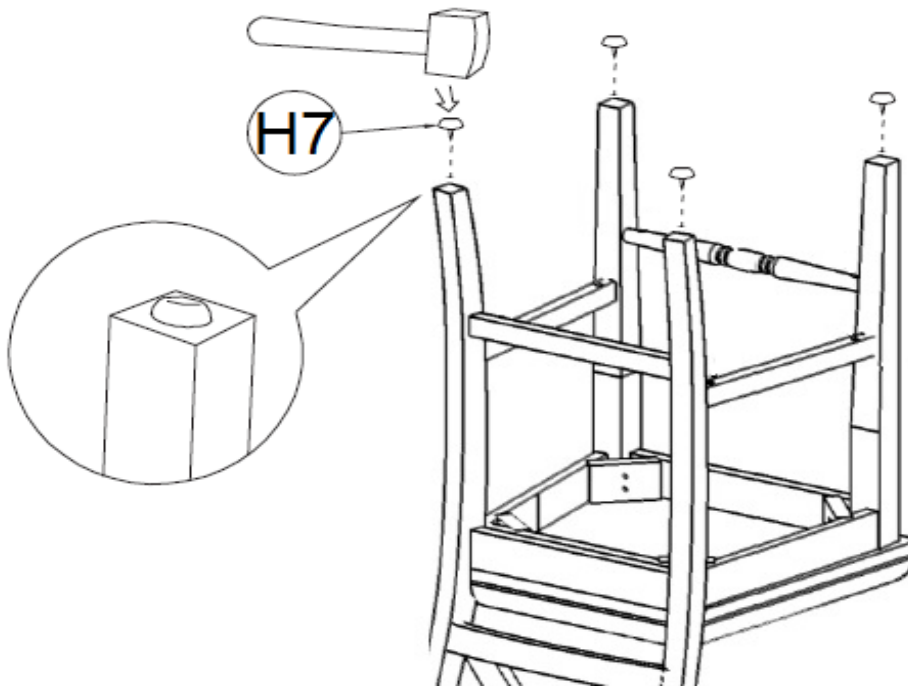

Place Leg Stud (H7) at the centre of the bottom end of each leg and use a mallet or hammer to lightly nail Leg Stud in place. Set the chair right-side up after all 4 leg studs are installed .

The assembly of the chair is complete .