

# **INSTALLATION**

## *Product Manual*

Version: 150257US-01-25A-LT

Cabinet Exploded View & Part List.....	3-5
Installation.....	6-15
Cabinet Display.....	16
Cabinet Settings and Function Introduction.....	17-19
Trouble Shooting.....	20
Customer Service & Warranty.....	21

## **Tips**

1. Please read the complete installation instructions carefully before assembling the cabinet.
2. Check the materials to make sure they are normal and not damaged.
3. Refer to the illustrations to identify the parts and accessories of the cabinet.
4. Align the holes and tighten the screws during installation.
5. Installation requires two people, and keep children away to avoid accidental injury.

(A) x1

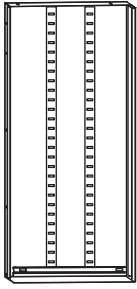

Left Side Plate

(B) x1

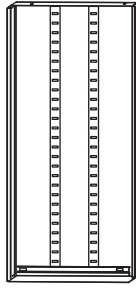

Right Side Plate

(C) x1

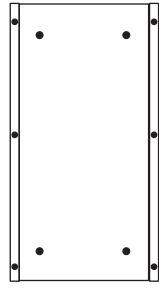

Back Plate

(D) x1

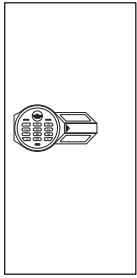

Door

(E) x1

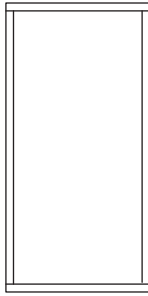

Door

(F) x1

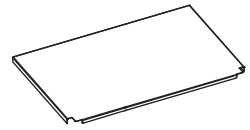

Bottom Plate

(G) x1

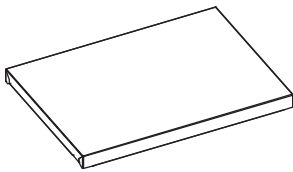

Top Plate

(H) x2

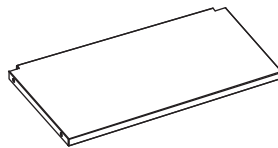

Shelf

(I) x1

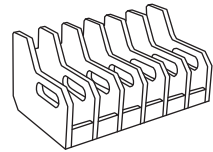

Pistol Rack

(J) x1

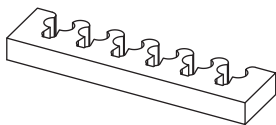

Gun Stock

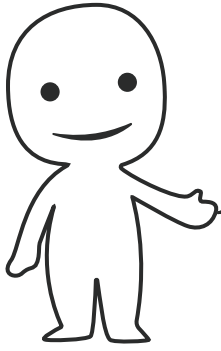

Please prepare the following tools

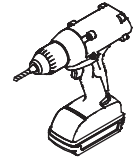
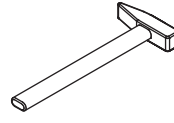
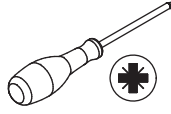
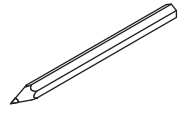

When installing, please carefully confirm whether each screw corresponds to the manual, accessories with similar shapes can be distinguished by size

K x 4

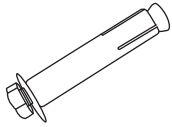

Expansion Screw

L x 4

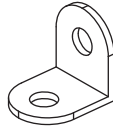

Fixed Buckle

M x 32



Screw

N x 1

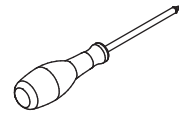

Screwdriver

O x 1



Sensor Light

P x 10

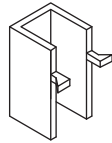

Top Buckle

Q x 10

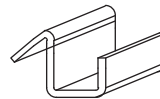

Bottom Buckle

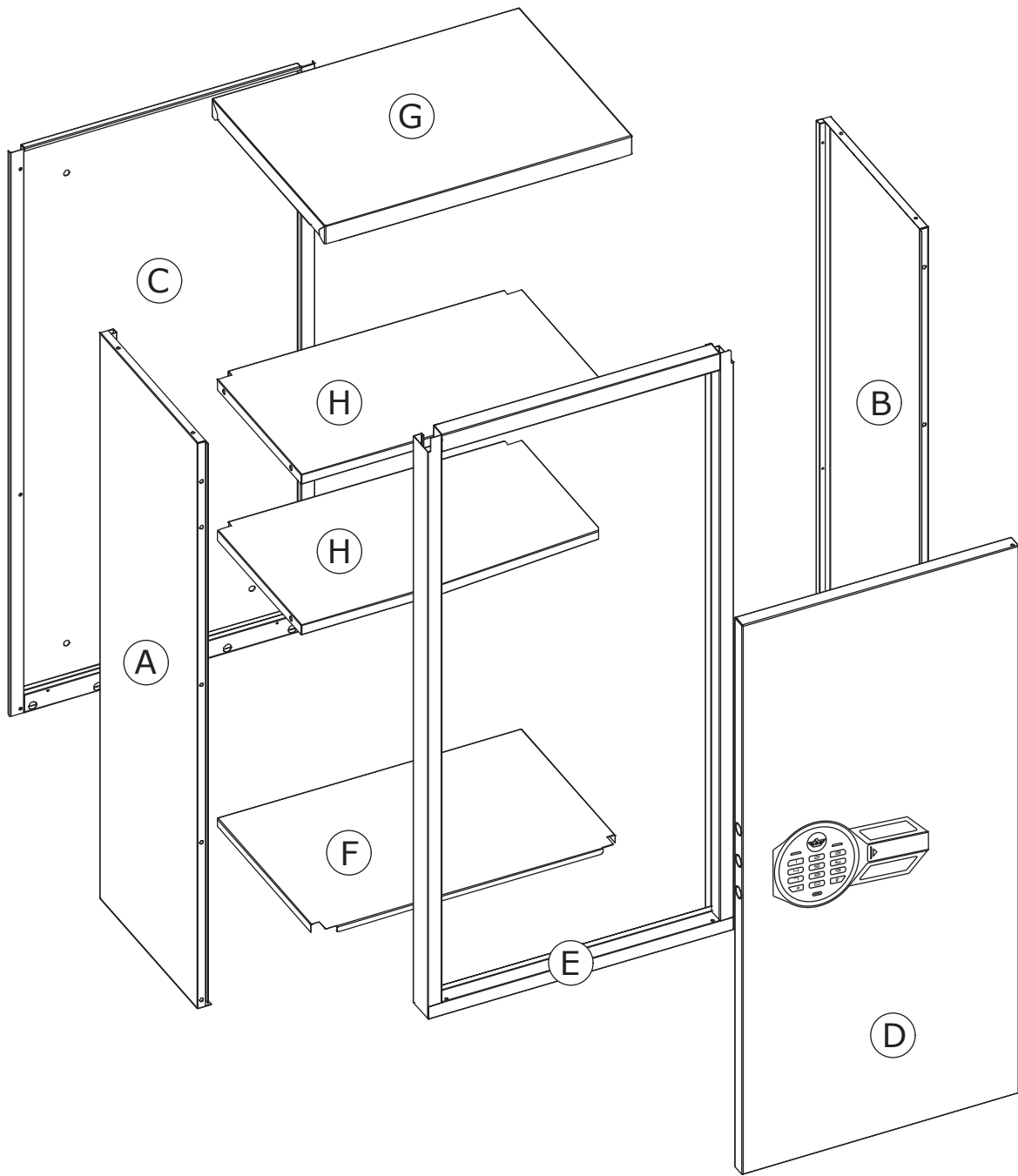

**! WARNING**

• Tip over hazard: Secure the cabinet!  
The cabinet can be tipped over by children or adults, please make sure the cabinet is mounted on the wall.

• Keep the keys in a secure place away from children.

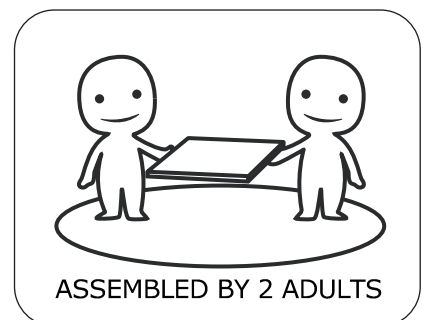

ASSEMBLED BY 2 ADULTS

1

M x 3  
Screw

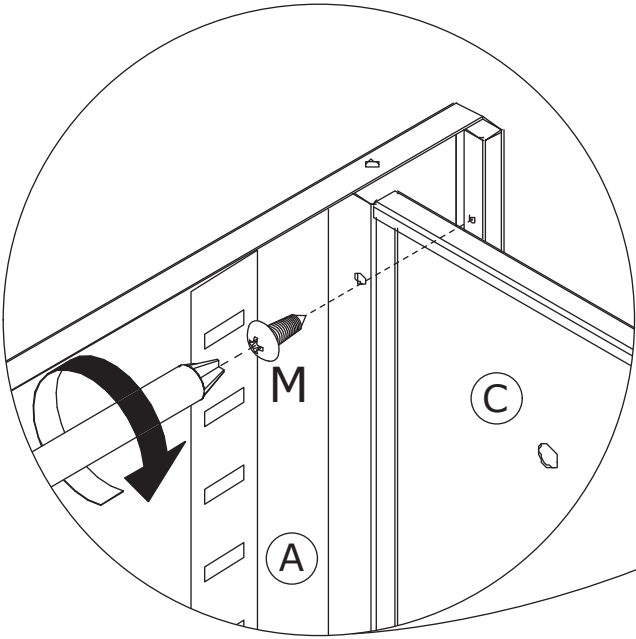

Fix(A) and(C) with screw(M).

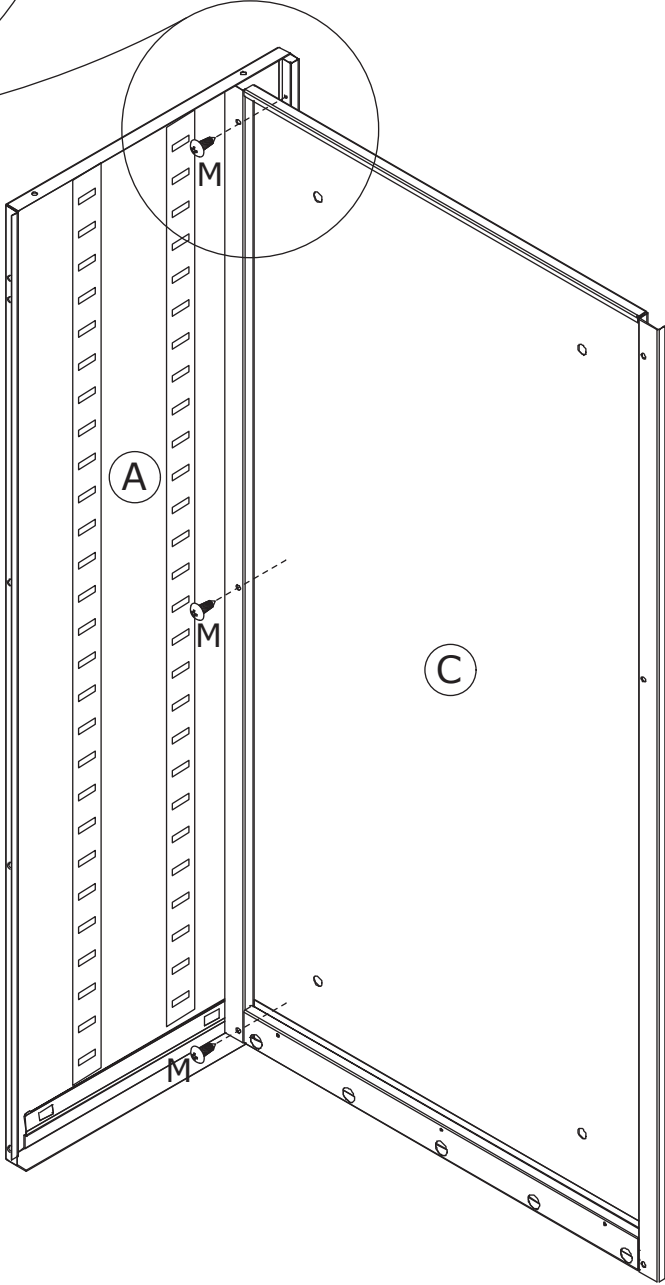

2

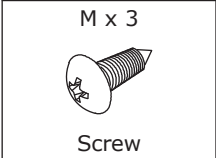

Fix(B) and(C) with screw(M).

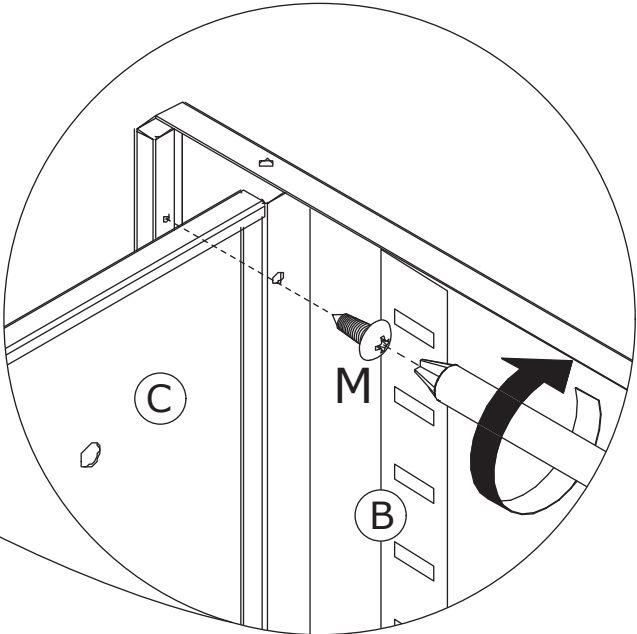
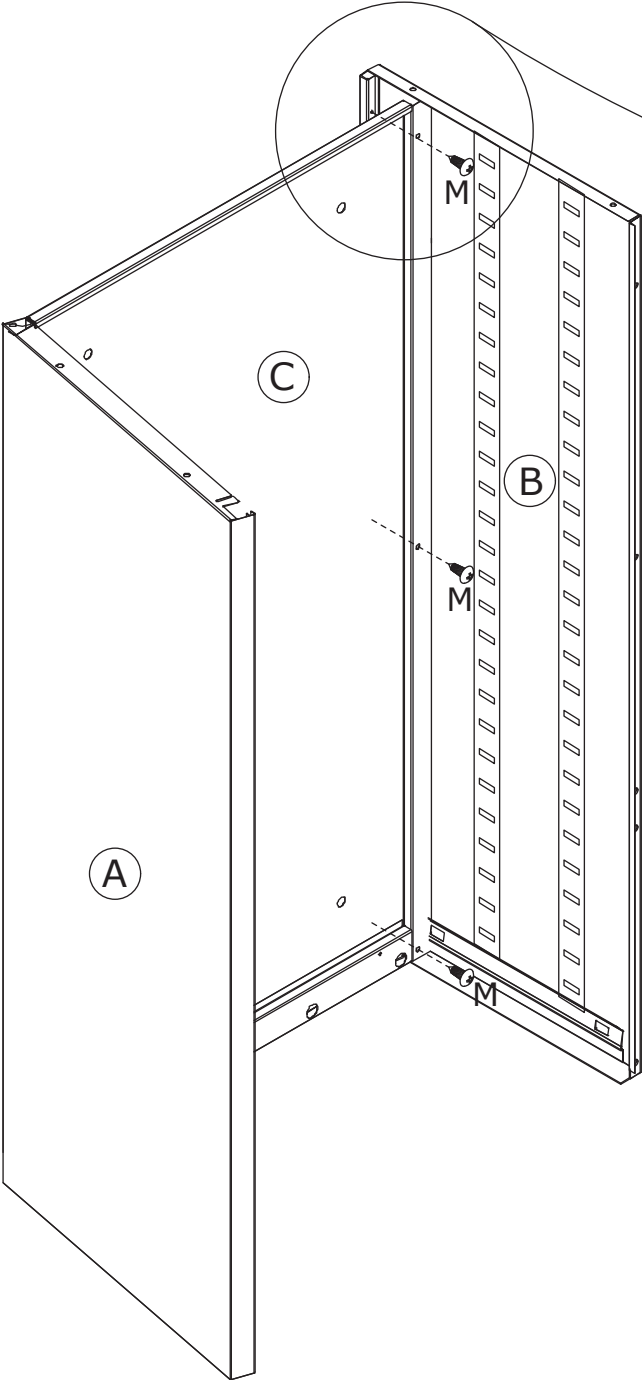

3

M x 6  
Screw

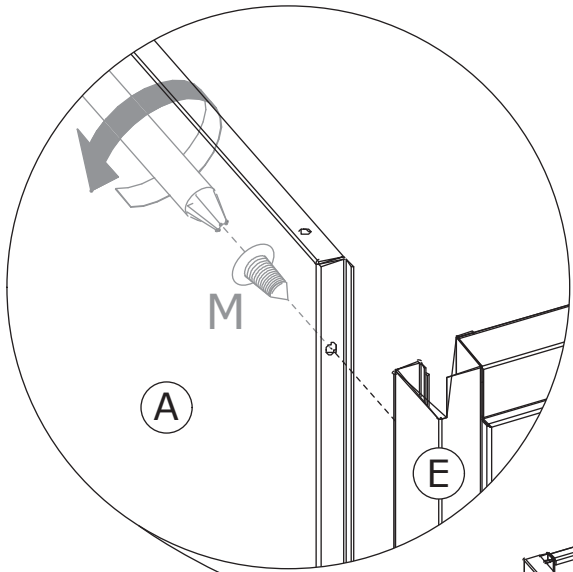

Fix(D) on both sides with screw(M).

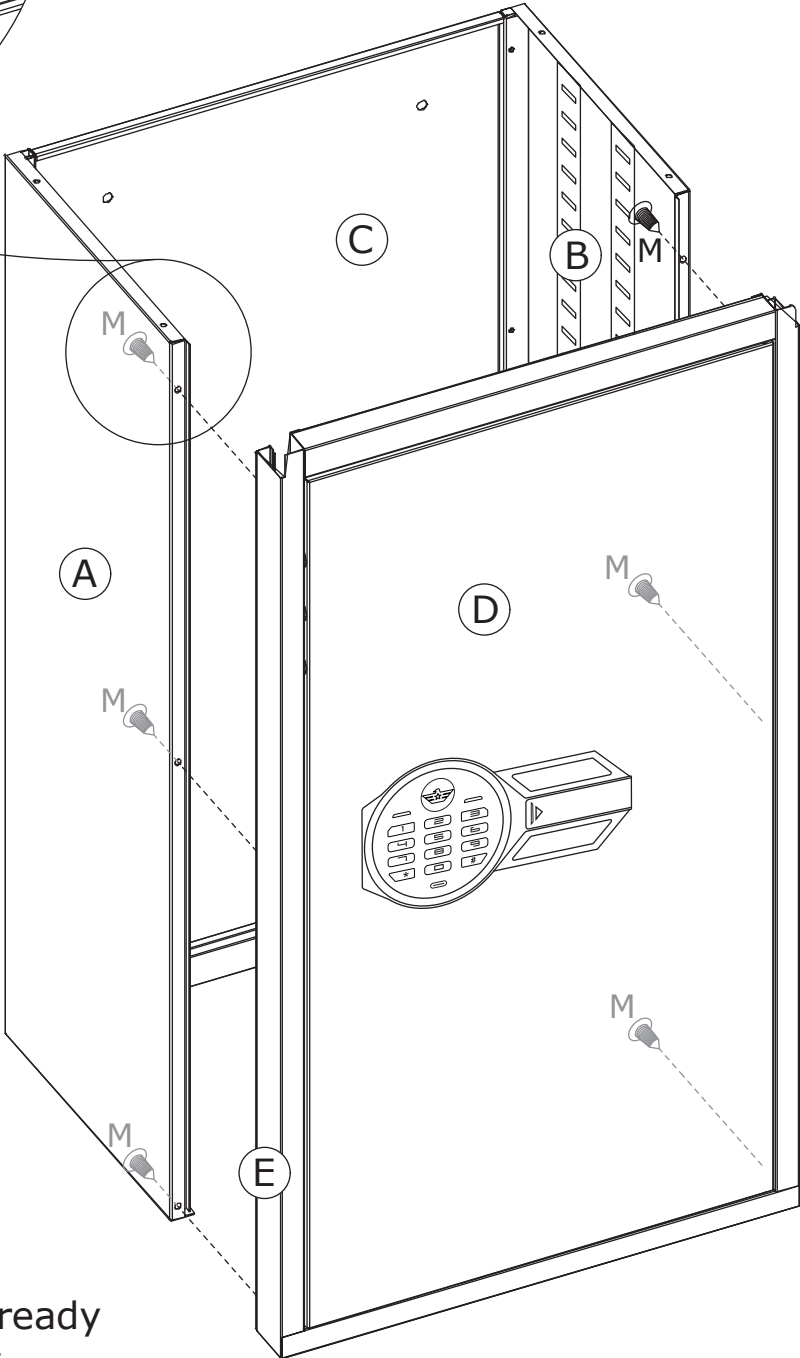

**NOTICE:**  
Parts(D) and (E) were already assembled at the factory.

4

M x 5  
Screw

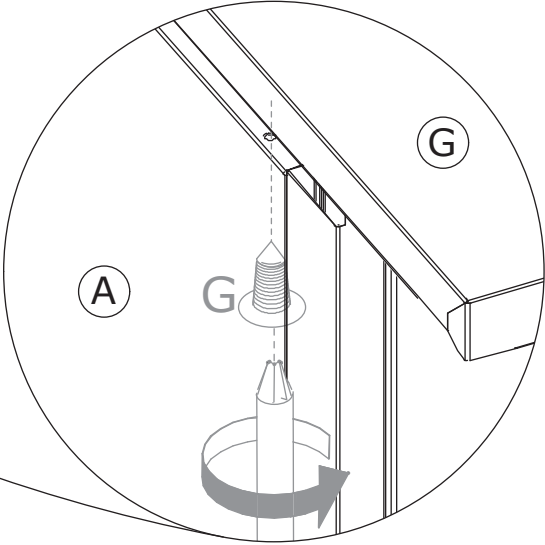
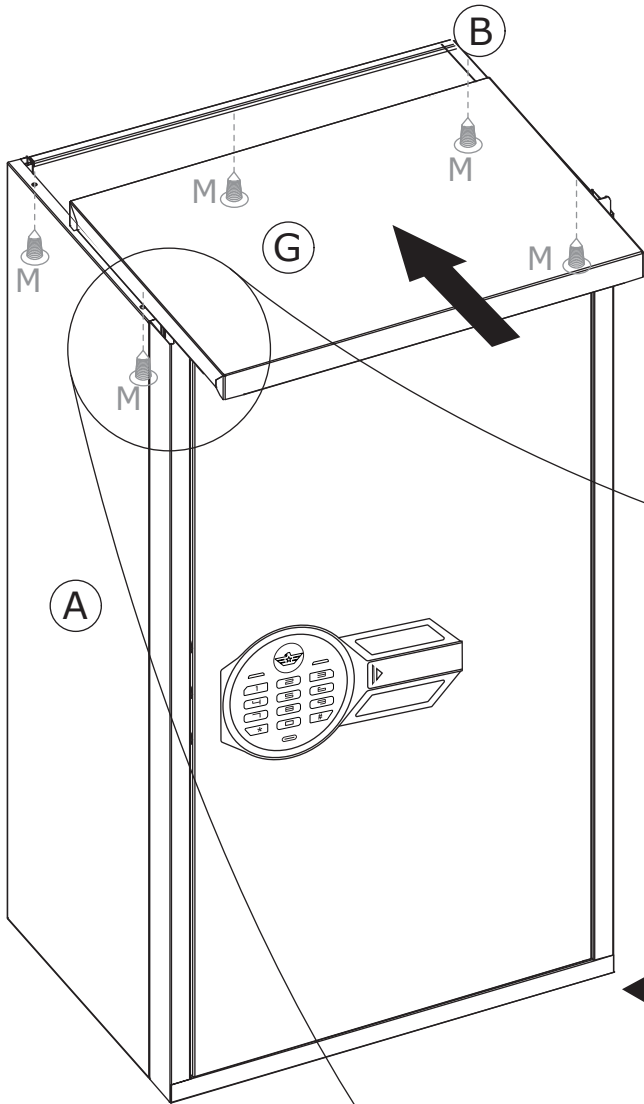

Install(G) and fix it with screw(M) from the inside.

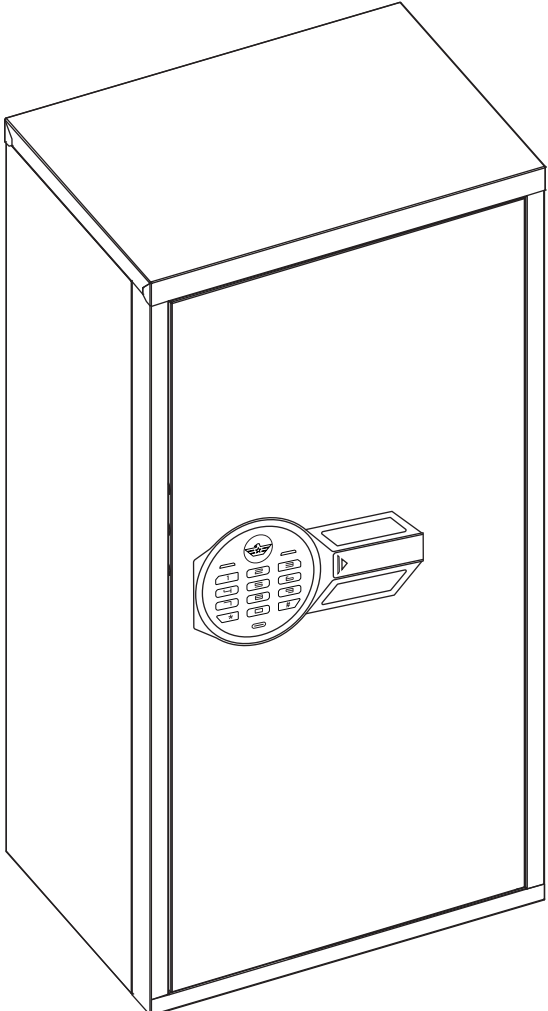

5

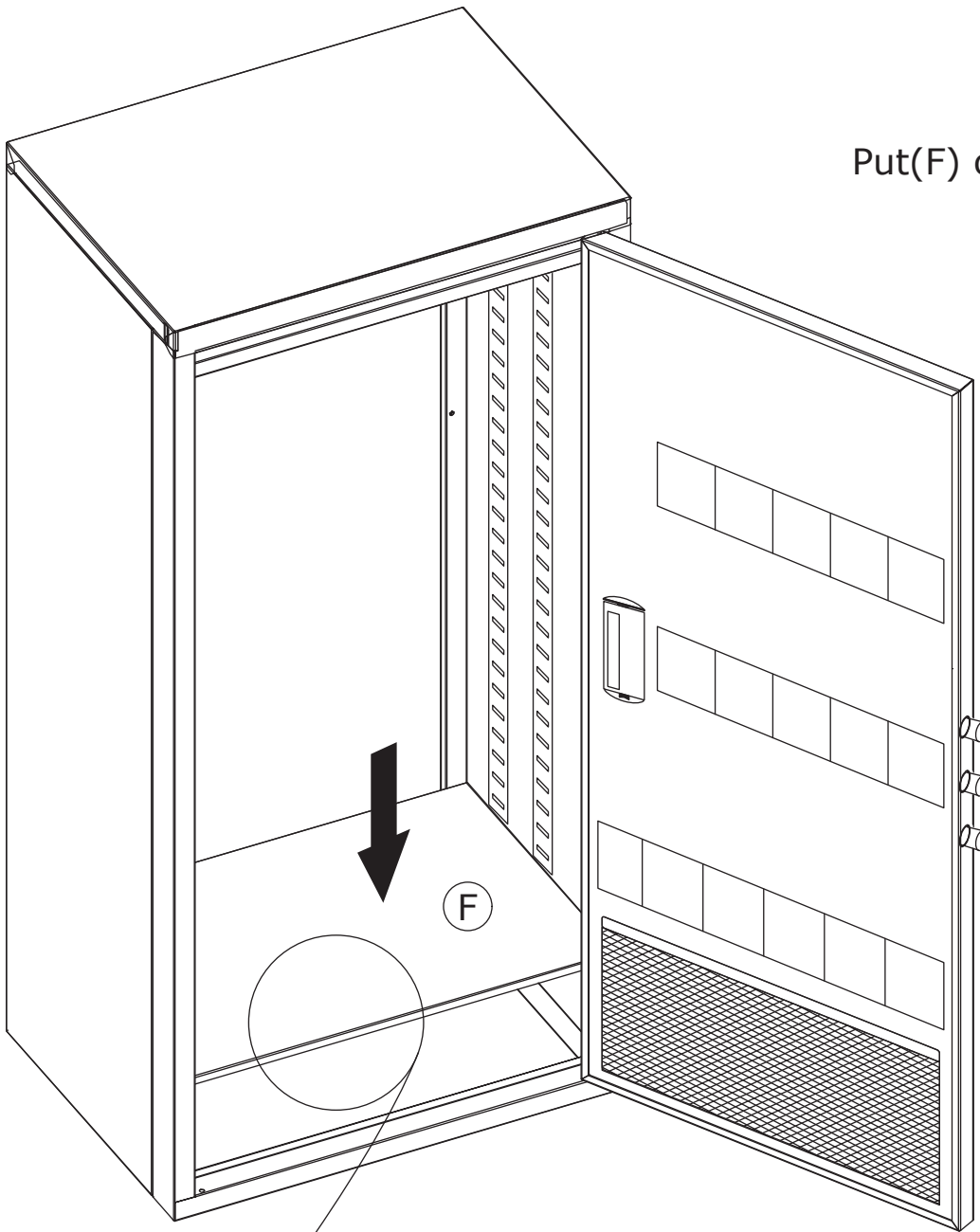

Put(F) on the bottom.



**NOTICE:**

Please lay the unit flat and adjust the feet to the same height as the surrounding area to increase the bearing capacity of the cabinet.

6

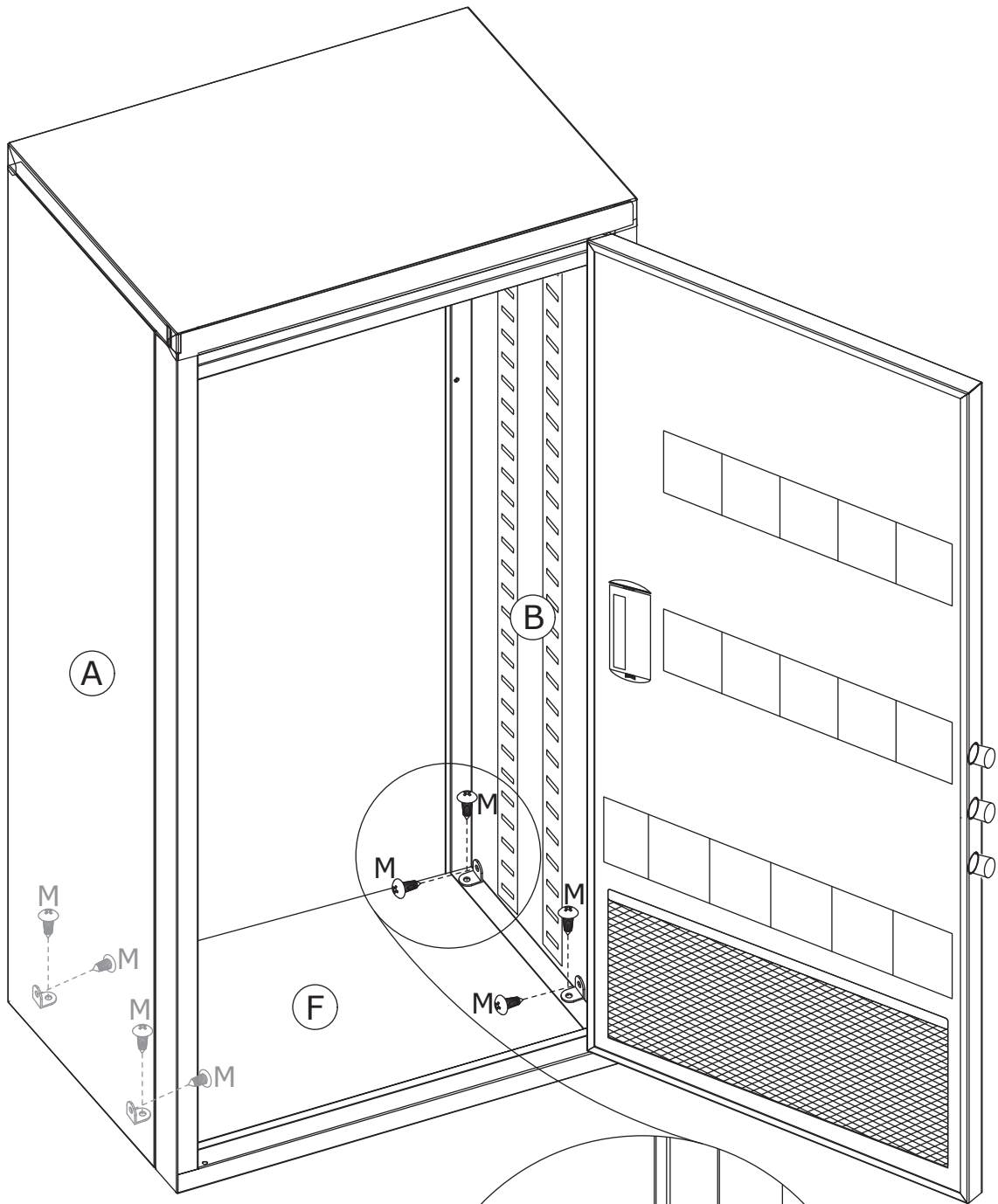

At the four corners of the interior bottom plate, there are eight pre-drilled holes. Fix the bottom plate with screw(M) and Buckle(L) as the picture shows.

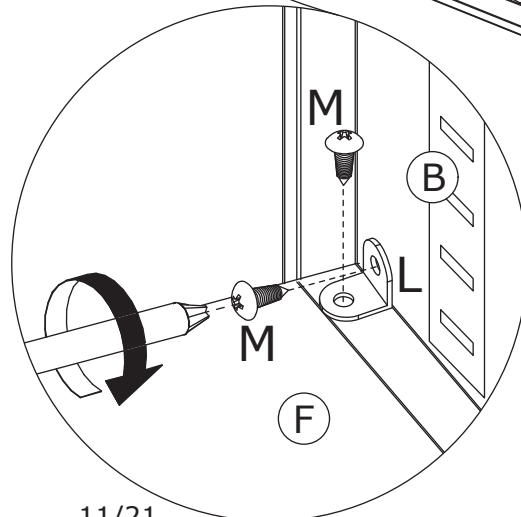

7

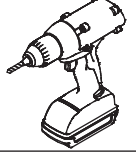
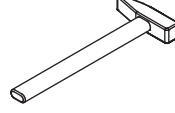
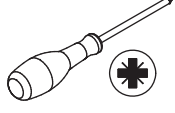
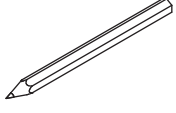
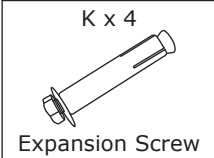

Fix the unit on the wall with Expansion Screw(K).

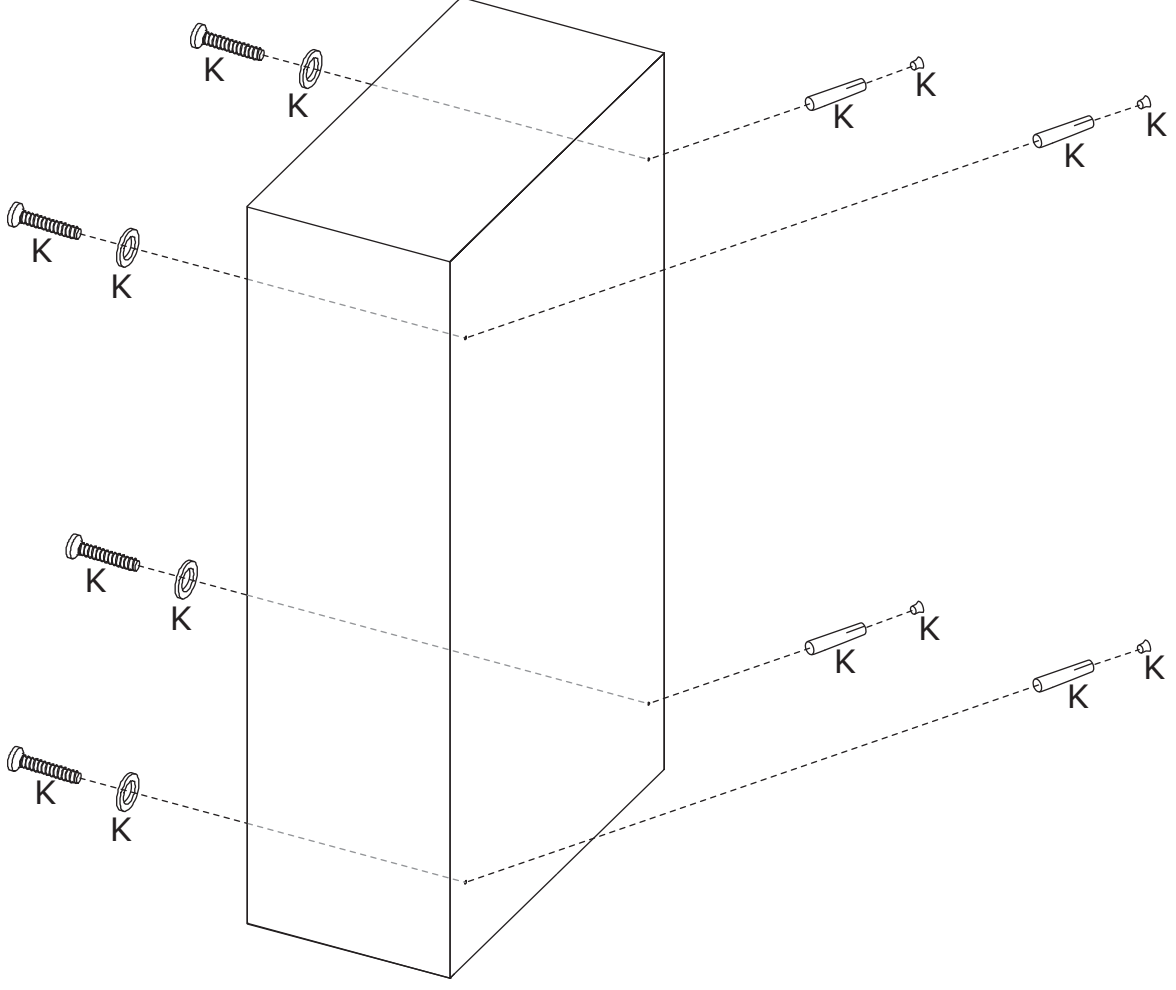

**NOTICE:**

If you want to use it alone. We suggest that you could mount the unit on the wall to prevent it from falling.  
If you choose to do so, do it in this step.  
Ignore this step if you choose to use it with our wooden cabinet.

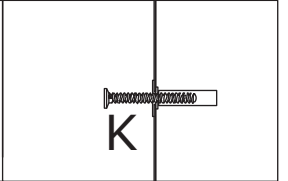
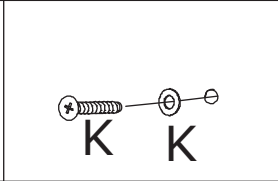
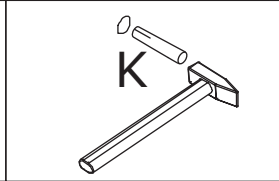
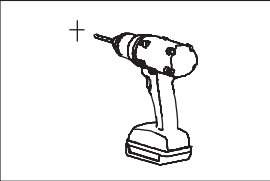
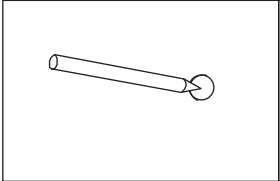

8

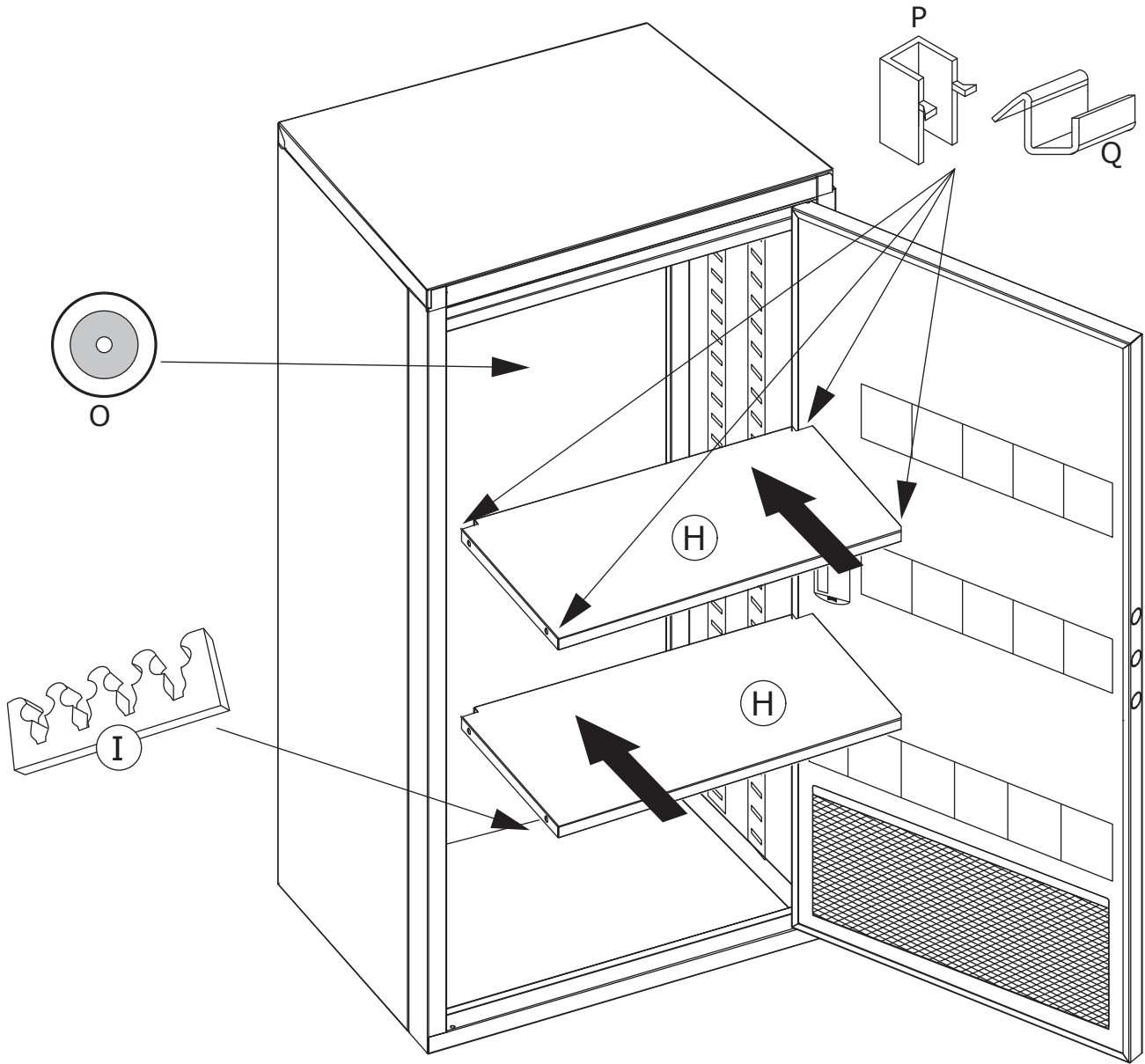
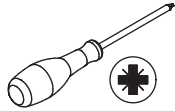
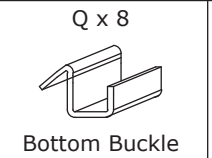
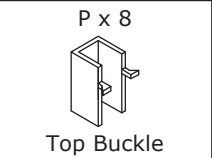
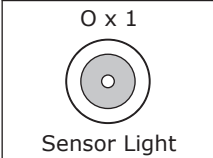

Fix(H) on both sides with Top Buckle(P) and Bottom Buckle(Q), (P) on the top and (Q) on the bottom. Then install (I) wherever you want, and you can adjust the position as needed.

You can install the Sensor Light(O) in any position you want (The sensor light requires three AAA batteries. It will light up when the door is open or object sensed).

9

### Step 1

Screw the nut into one end of the rod.

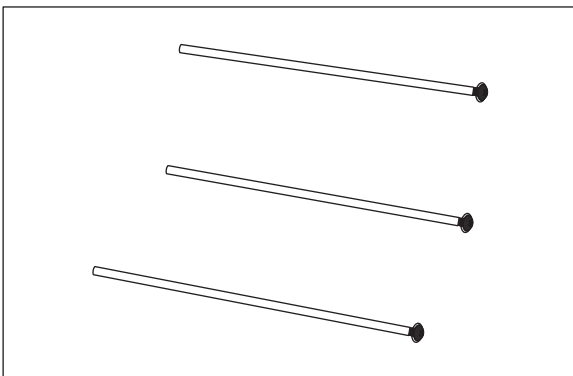

### Step 2

Align the holes and pass the PVC sheet through the rod first, then through the foam base.

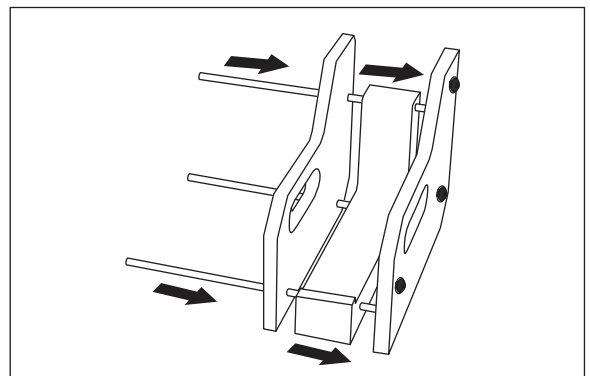

### Step 3

Do step 3 repeatedly until all foam bases and PVC sheet are inserted.

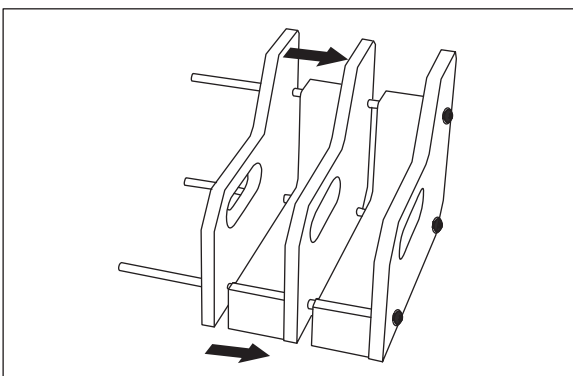

### Step 4

Use 2 hex wrench provided, the one for screwing the nut and the other for preventing the rod from spinning.

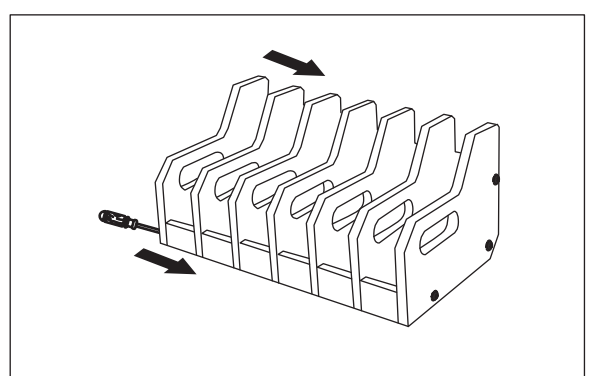

10

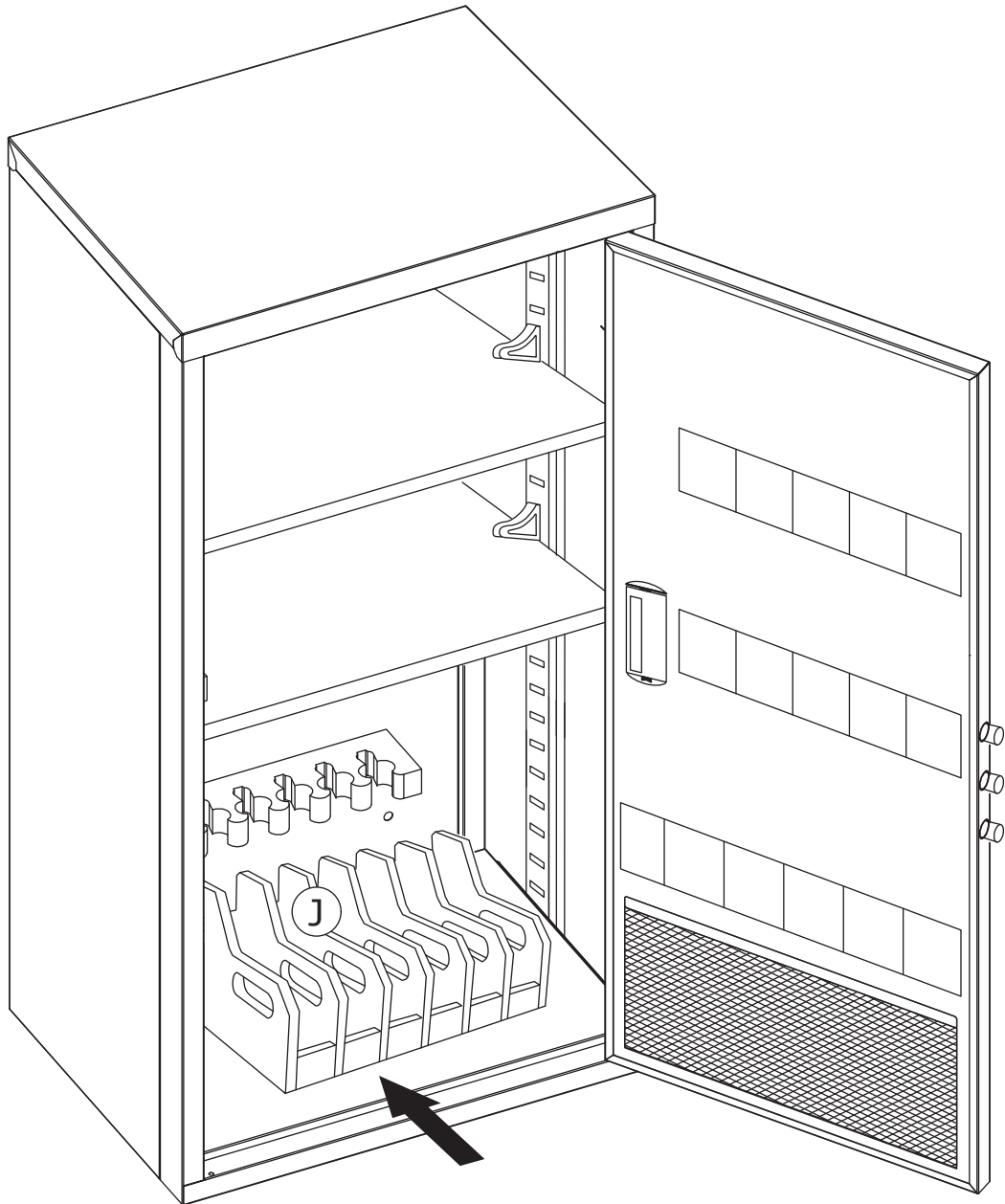

Install(J) wherever you want, and you can adjust the position as needed.

11

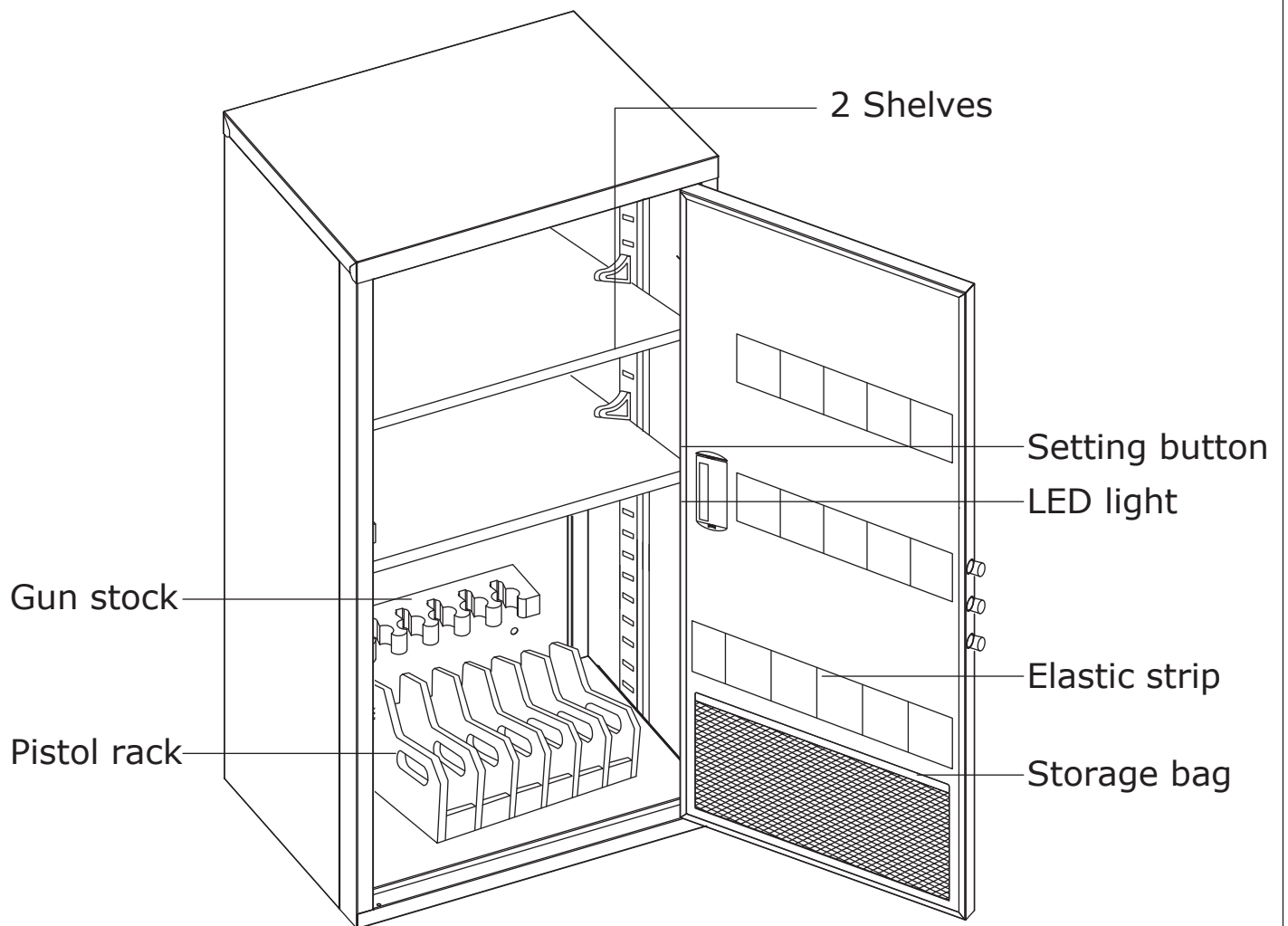
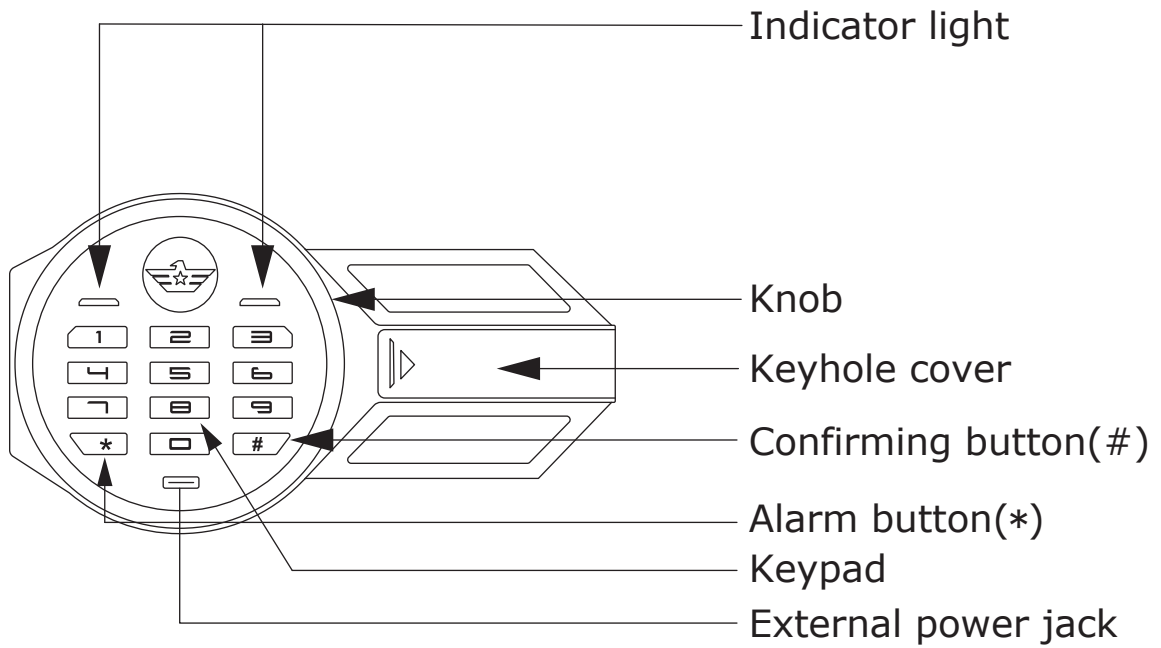

**NOTICE:**  
Different size have different door organizer.

## First Opening

- 1.Right slide the emergency keyhole cover.
- 2.Insert the emergency key into the key hole and turn it counterclockwise.
- 3.Turn the handle clockwise to open the cabinet.
- 4.Open the door, and then open the cover of battery box.
5. Insert 4 AA batteries (not included).

### IMPORTANT

1. Please do not use rechargeable batteries.
2. Do not mix different brands of batteries, as it may burn the panel.
3. If the panel is not powered after installing the battery, please check if the battery is low.

## The First User Code Programming

- 1.Open the cabinet, keep the cabinet opening, short press the setting button (on the inner side of the door) , the cabinet beeps once and keypad light on.
- 2.Input a new code(3-12 digits),then press # to confirm. The buzzer plays a chord,indicating that the code is successfully set.
- 3.Testing the code before you close the door.

### IMPORTANT

It is recommended that users change the default code "123456" as soon as possible after opening the cabinet for the first time to prevent unauthorized access to your cabinet.

## The Second User Code Programming

1. Open the cabinet, keep the cabinet opening, enter 0 twice, then short press the setting button (on the inner side of the door), the cabinet beeps once and keypad light on.
2. Input a new code(3-12 digits),then press # to confirm. The buzzer plays a chord,indicating that the code is successfully set.

### IMPORTANT

- 1.10 seconds without any operation after pressing the setting button, it will go back to standby mode, you need to retry.
2. Please set up both of two codes immediately after receiving the cabinet.
3. A single beep indicates that the code has been set successfully, thrice beep indicates that the two codes entries are inconsistent, please repeat the procedures.

## Silent Mode Setting

In standby state, press 1 twice, then press #, there is a long beep , indicate the mute function is turned on/off.

### **NOTICE:**

Under the mute function, the wrong code alarm and vibration alarm still work, and the alarm will sound when triggered.

## Low Battery Warning

After installing the batteries or entering the code, if the cabinet is consistently beeping, it indicates that the battery power is low and new batteries need to be replaced.

## Dual Alarm System

- 1.After 3 consecutive times of wrong code, your cabinet will activate the alarm system, the alarm will sound for 30 seconds, enter the correct code and the alarm will be cancelled.
- 2.In standby state, press \*, there is a beep and all the lights came on at once, the vibration alarm mode is turned on. If the box is shaken or hit violently, it will give an alarm immediately for 30 seconds, at this point, enter the correct code to stop the alarm.

### **NOTICE:**

- 1.When power on, the system default for alarm is off.
- 2.After cabinet is opened with code, the vibration alarm will turned off and needs to be turned on again.
- 3.When you forget the code, the alarm can be stopped by using the key to open the cabinet and remove the battery to cut off the power.

## Restore Factory Settings

Keep pressing the setting button for 3 seconds until you hear a chord, indicating that the reset has been successful. At this point, all codes will be invalid and need to be reset.

### **NOTICE:**

The default code is"123456".

# Three Ways to Open the Cabinet

## 1.The first way to open: Use the emergency key.

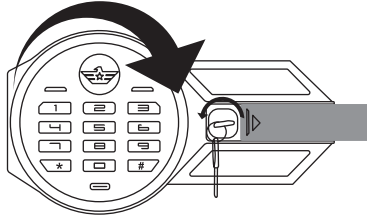

Insert the emergency key into the right keyhole, turn counterclockwise to the limit and hold still, then rotate the knob clockwise to open the cabinet (Suitable for the first opening, forget code or weak battery).

## 2.The second way to open: Use the code.

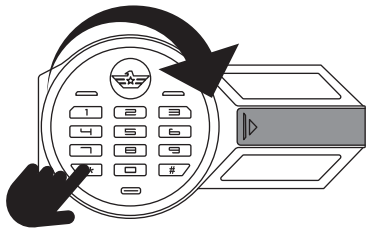

After installing the battery, enter your code and then press the # key to confirm, rotate the knob clockwise to open the cabinet (Suitable for quick access and daily use).

## 3.The third way to open: Use the usb type-c cable + code

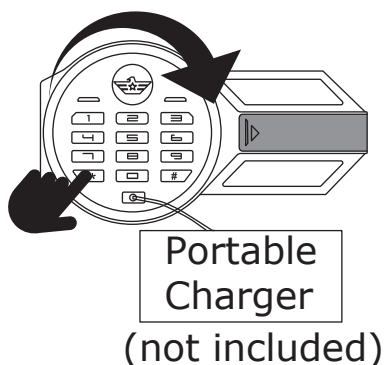

When the battery of your cabinet is weak and you can't find the keys, please plug one end of usb type-c cable into the emergency power hole and plug the other end to the portable charger (not included), then enter the correct code to open the door (Suitable for the battery is out of power and the key can not be found).

# Trouble Shooting

Malfunction	Cause	Solution
Inserting the battery does not work	Battery drained	Replacement battery
	Electrode reversed	Put the battery in the correct position
Can't open with code	Low battery	Replace with new battery
	Wrong code	Please reset your code
Unlocked but the door won't open	The key is not turned to the specified position	After turning the key to the specified position, turn the knob to open
	The knob is not turned within 5 seconds of entering the code	After turning the key to the specified position, turn the knob to open
Cannot be locked	Key not pulled out	Lock the door after removing the key
LED won't light up	Use the key to open the cabinet	Use the electronic code to open the cabinet
Cabinet wobbling	The screws are not tightened	Tighten the screws

## Maintenance

1.If you do not use the cabinet for a long time, please take out the battery to prevent the battery fluid from leaking and damaging the cabinet.

2.Please keep the keys and USB type-C cable in a secure place, do not lock them inside the safe.  
It can open the cabinet when it is out of power or if you forget your code.

3.Store the cabinet in a cool, backlit place.

4.Do not wipe the cabinet with corrosive chemical solvents, use a clean rag to wipe with a little cleaning agent.

# Customer Service & Warranty

We feel confident that you will love our cabinet. If there's something makes you unsatisfied, please don't hesitate to contact us. Many issues can be quickly resolved without the product being returned.

## **LIFETIME KEY SERVICE:**

We offer 1 Year warranty service and lifetime key service. If your key is lost or damaged, please provide your order ID, shipping address and the serial number on the lock cylinder of the cabinet, via messages, we will give you the most satisfactory reply within 24 hours.

## **NOTICE:**

If the key is lost or damaged due to personal reasons, we will bear the cost of the replacement key, but you need to take charge the cost of shipping.

**Thanks for your understanding.**

# WARRANTY

## WARRANTY CLAIMS

- There is a 30-day warranty for broken furniture or any other problems that do not work properly. The warranty will start from the date of purchase which must be verified by proof of purchase.
- Before making a claim, we may be able to answer your query, simply call us. Please leave your purchase order number, along with some details of the problem, if you want a replacement part. We will arrange within 48 hours. If there is out of stock, we will reply with a shipping date.
- The product must be used in accordance with the instructions provided. For health reasons.
- For other reasons, if the furniture needs to be returned, it must be cleaned and dried and operated within 30 days of receipt.

## Type of Warranty Claim

- Failure to follow the furniture instructions will invalidate the warranty. Attention please.
- Does not include damage during installation, but includes damage during transportation.

## Scope of responsibility

- Shall not bear any responsibility for misuse or user damage and / or loss of parts during the installation of furniture.
- After using, the damage and scratches of the furniture are not covered by the warranty.

## The Warranty Relates to All Bought in The Us and Covers The Following Areas

- Sheet parts: 1 month from the date of purchase.
- Electrical parts: 1 month from the date of purchase.

# RETURNS

## CHANGED YOUR MIND AND NEED TO RETURN YOU ITEM?

### PLEASE FOLLOW THE BELOW INSTRUCTIONS:

- If you have purchased and have simply changed your mind, follow the retailer's instructions for returns.

### DEFECTIVE ITEMS

- If your item is defective in any way, i.e. it doesn't work but you can't identify why, in the first instance, please call us.

### DAMAGED ITEMS

- If you receive an order with obvious shipping damage from the retailer, then we suggest the delivery is refused. If the delivery has been accepted and then shipping damage is found, please follow the specific instructions advised by the retailer.  
In all circumstances please save all packaging material and paperwork for the order. Please be aware that if you dispose of packaging material or attempt to return the merchandise without contacting the fulfiller, you jeopardise your chances of making a claim, and you may not receive a credit for the return.

### AFTER-SALES CONTACT



adelahu@fufugaga.com



208-820-0068