











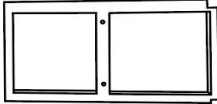
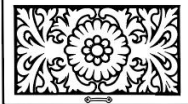
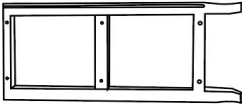

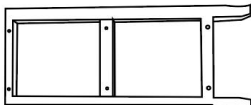

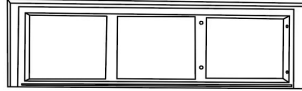
Assembly Instructions

Laying out all the parts and hardware and identifying each part as shown may help you when you assemble the table.

ITEM	PART	QTY	ITEM	PART	QTY
A		1	K		1
B		1	L		2
C		1	M		1
D		1	N	 Allen wrench	1
E		1	O		8
F		1	P		12
I		2	Q		12
J		1	R		6
G		4			

Step One

Place component E upside down. Insert G into E. Then insert panels C, B, and D into their designated slots as shown in the example.

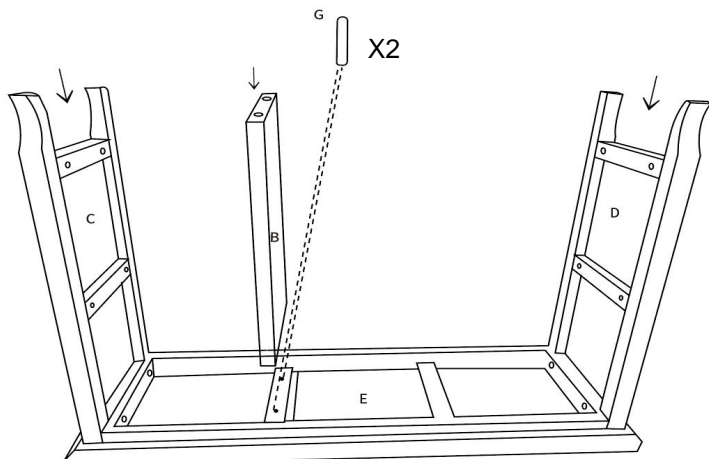

Step Two

Align panel I with the slot on component E and insert it. Next, insert panel F. Then, align another panel I with the slot on panel F and insert it. Last, insert G into B.

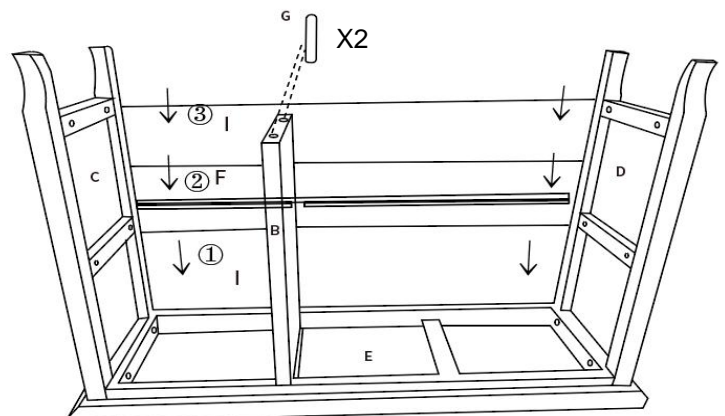

Step Three

Snap panel A into place.

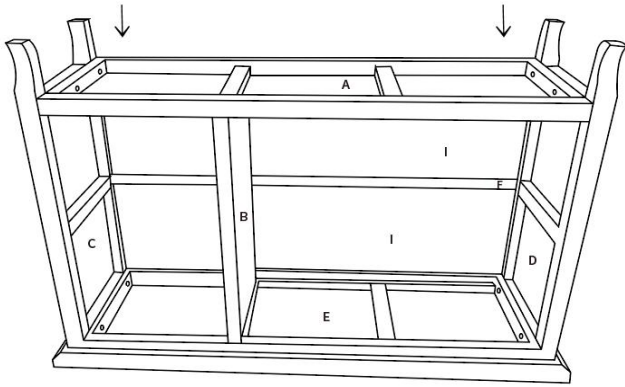

Step Four

Tighten the screws connecting components A, E, C, and D.

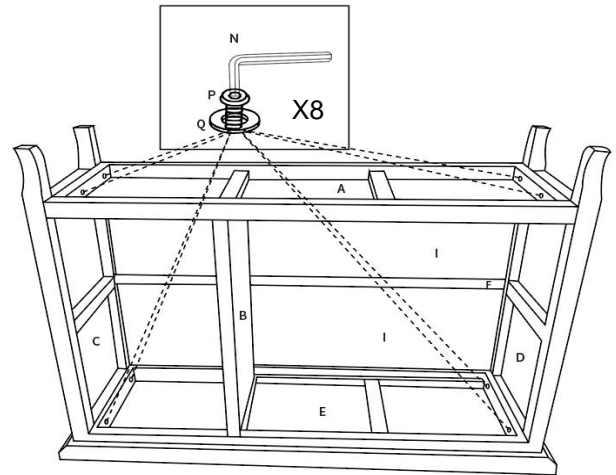

Step Five

Tighten the screws connecting components A, B, and E.

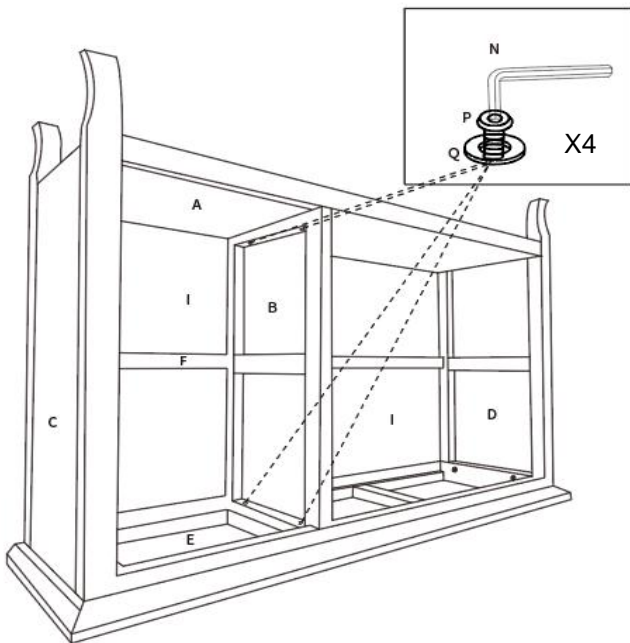

Step Six

Insert panels J and K, then secure them by tightening the screws connected to panels B, C, and D.

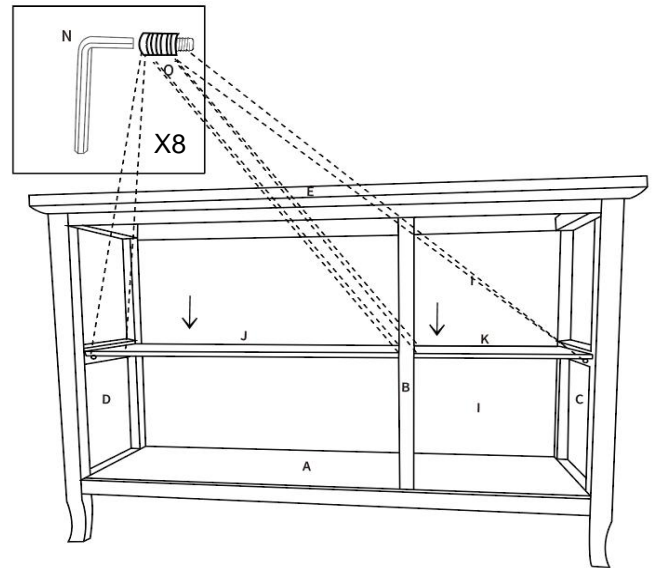

Step Seven

Use connector R to link components D, M; components B, L; and components C, L.

