

# ASSEMBLY INSTRUCTIONS

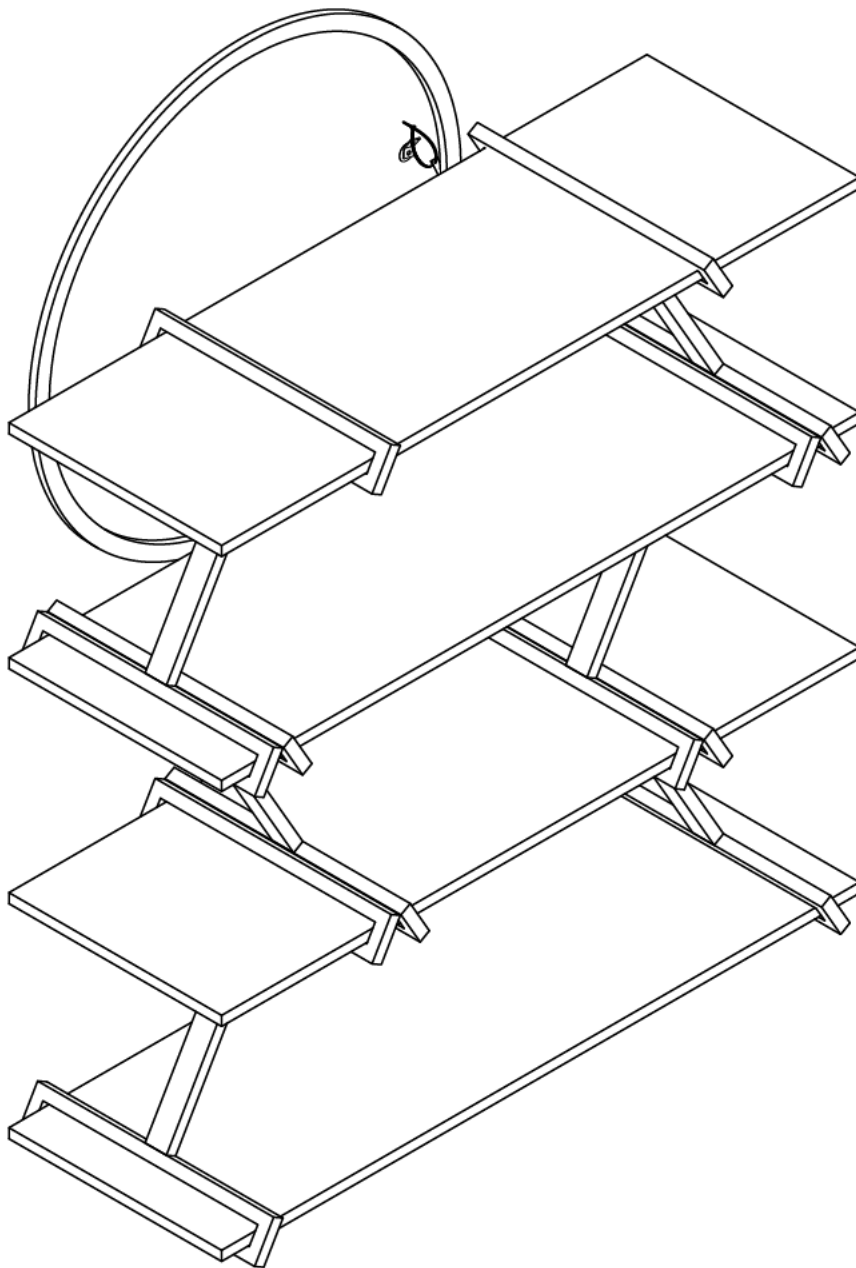

## TOOLS REQUIRED



**Phillips  
Screwdriver**  
(Not Included)



**2 - People  
Recommended**

## ASSEMBLY RATING



**EASY** ————— **DIFFICULT**

The Assembly Rating is a 5-point system showing the level of effort needed to assemble a specific product.



## **CHECK BEFORE STARTING**



### **Are you missing anything?**

Double-check all parts, hardware and accessories listed on Page 6 are accounted for.



### **Check out our Quick Tips!**

We recommend reviewing the pre-assembly handouts. Even experts need a refresher now and then!



### **Should we send any replacements?**

Are there any irregularities or flaws in the parts? We can send replacements!



### **Prep Time!**

Please review the assembly instructions and all diagrams prior to assembling. Arrange parts as recommended on Page 7 and group identical hardware together to make assembling easier.

# PRE ASSEMBLY INTRODUCTION

We understand building ready-to-assemble furniture can be a challenging experience for some. To help avoid confusion, we have provided some helpful tips that may speed up the process.



## Teamwork

ALWAYS have at least two people to help with transporting and assembling the product to avoid potential injury and/or damage.



## Suitable Location

Assembling near the area of the intended location is highly recommended.



## Sufficient Space

Make sure you have enough space to move around during the assembly.



## Avoid Scratches

Use cardboard, blankets or a carpeted area while assembling furniture to prevent scratches.

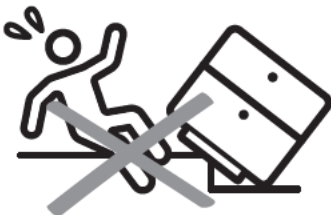

## Flat Surface

Make sure the furniture rests on a flat and level surface with each leg evenly touching the floor.

# ASSEMBLY AND CARE ADVICE



**FAILURE TO FOLLOW THE GUIDELINES BELOW MAY RESULT IN INJURY AND/OR PROPERTY DAMAGE.**



Position each part correctly and insert screws or bolts into their respective holes.

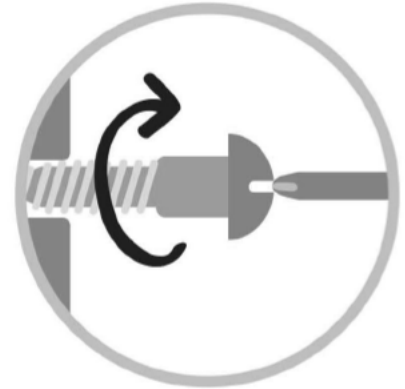

Turn clockwise to tighten and only tighten when step is completed or when instructed to do so.



Use the appropriate hand tools or power tools for assembly. Select steps, such as tightening screws and/or bolts, may require hand tools to avoid causing damage during assembly.



Save the instructions and store any supplied tools for later maintenance.



After two weeks, check and tighten any loose hardware and repeat again every six months thereafter.

**IT IS THE USER'S RESPONSIBILITY TO MAINTAIN THE FURNITURE. THE HARDWARE MAY LOOSEN OVER TIME AND MAY CAUSE THE FURNITURE TO BE WOBBLY AND UNABLE TO SUPPORT ITS INTENDED WEIGHT CAPACITY. THIS MAY LEAD TO COLLAPSE AND MAY CAUSE SERIOUS INJURY.**

# BOOKCASE



- Please keep instructions for future reference.
- Check the quantity and irregularity of parts and hardware before you start.

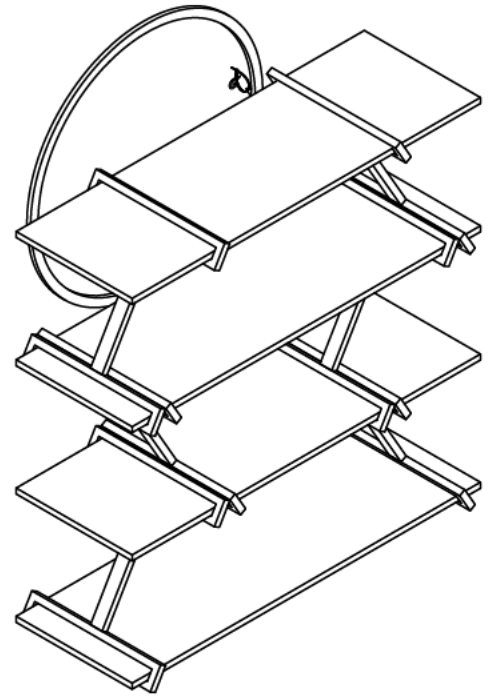

## PARTS

#1 6pcs

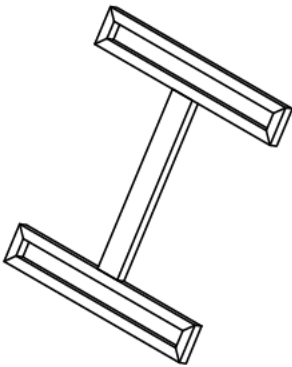

Connecting Frame

#2 1pc

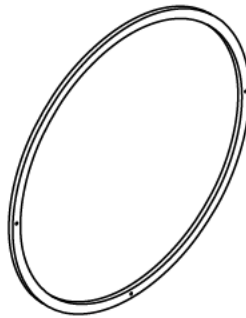

Back Circle Frame

#3 1pc

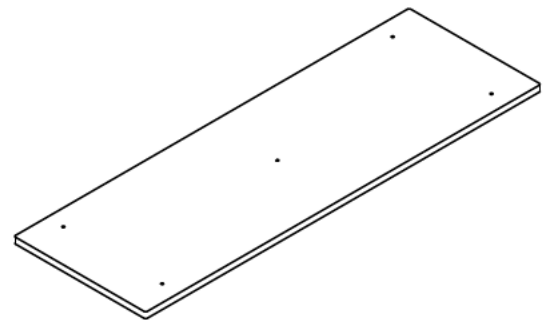

Bottom Board

#4 3pcs

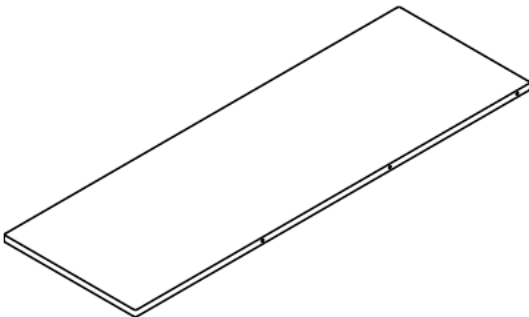

Upper Board

# HARDWARE

#A 3pcs



Screw  $\phi 4 \times 32 \text{mm}$

#B 3pcs



$\phi 12 \text{mm}$

#C 1pc



Leveler  $\phi 5/16''$

#D 4pcs



Leveler  $\phi 1/4''$

#E 1pc



Screw  $\phi 4 \times 50 \text{mm}$

#F 2pcs



Bracket

#G 1pc



Restraint Strap

# ASSEMBLY INSTRUCTIONS

1

Part #3 x1pc

Hardware #C x1pc

Hardware #D x4pcs

Assemble the Leveler (#C, #D) to Bottom Board (#3).  
Note: Do not fully tighten the Leveler (#D) until assembly is complete.

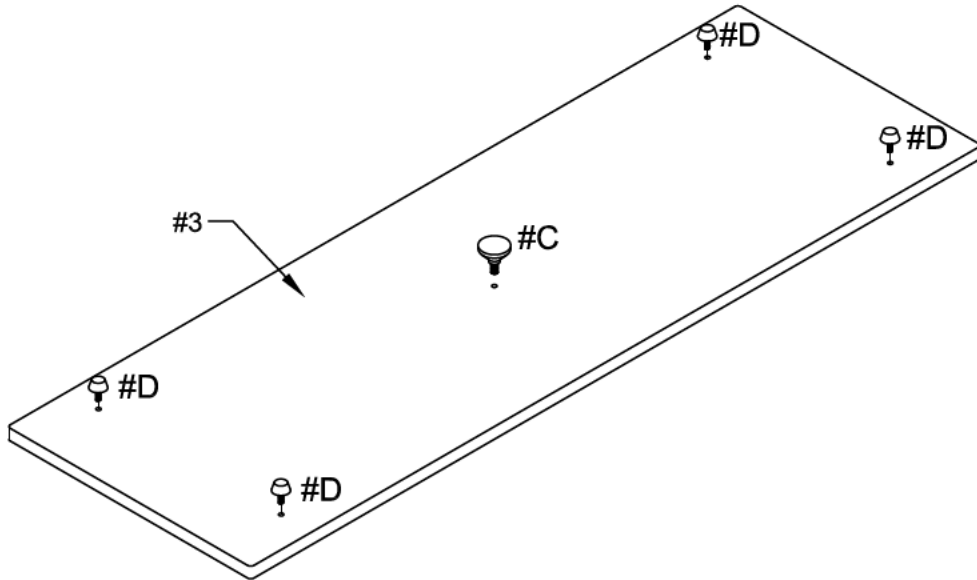

2

Part #1 x2pcs

Align and insert the Bottom board (#3) into the connecting frames (#1), place connecting frames (#1) to the position of the adjusting feet.

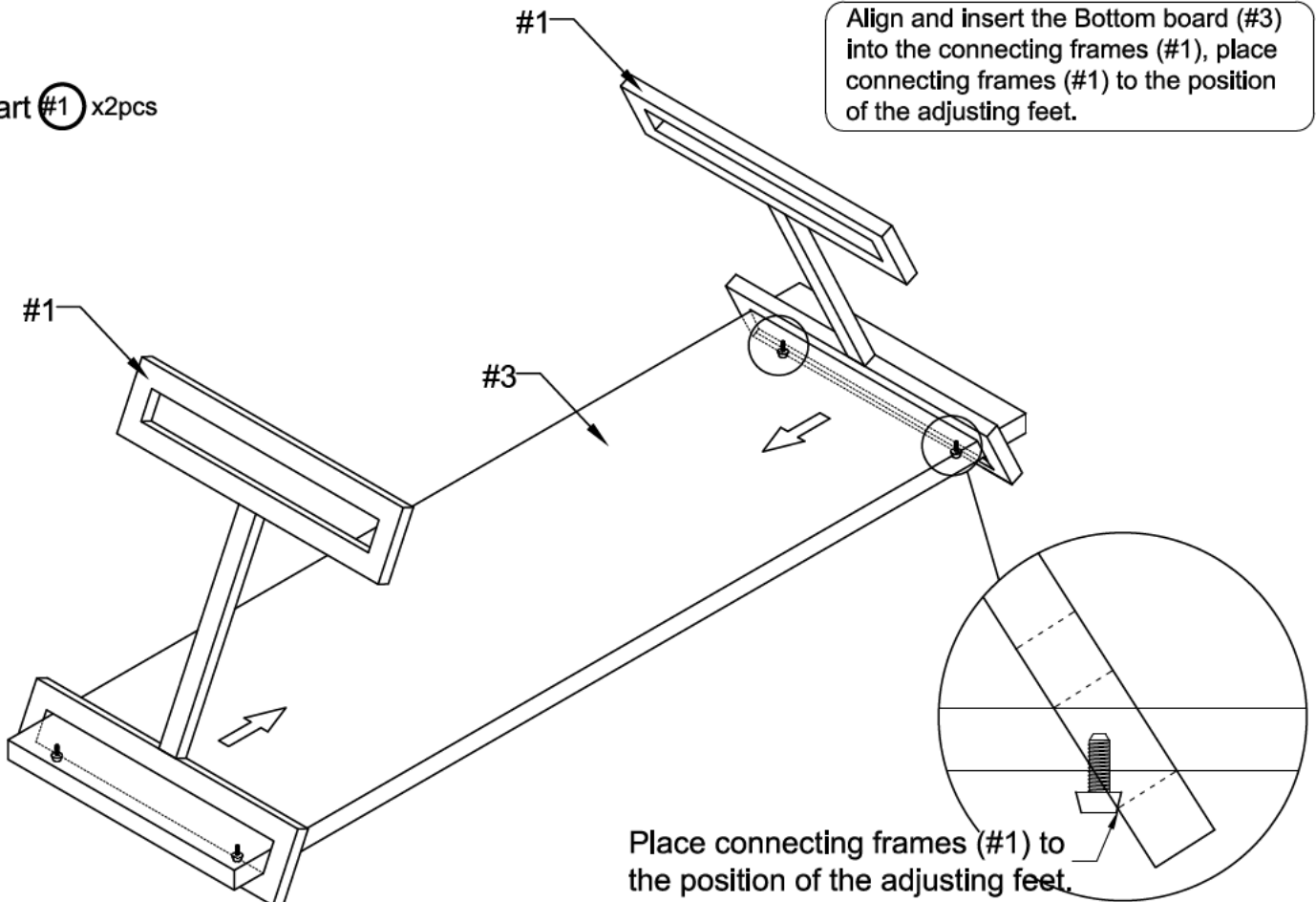

Place connecting frames (#1) to the position of the adjusting feet.

# ASSEMBLY INSTRUCTIONS

## 3

Part #1 x2pcs

Part #4 x1pc

Align and insert the Upper board (#4) into Connecting frames (#1).

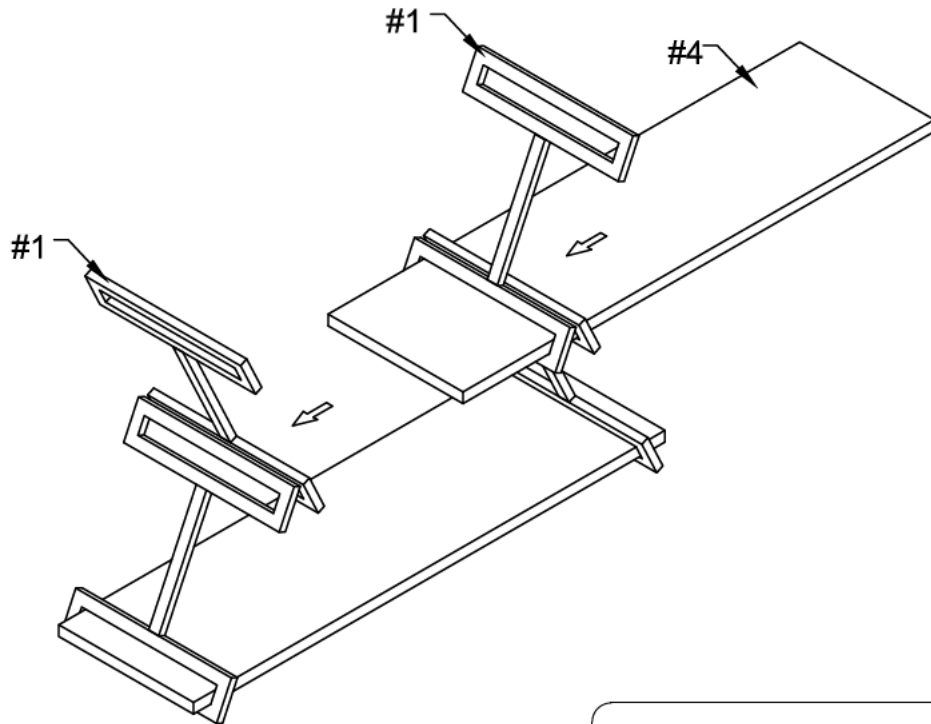

## 4

Adjust the position of the Upper board (#4), to align it with bottom board (#3).

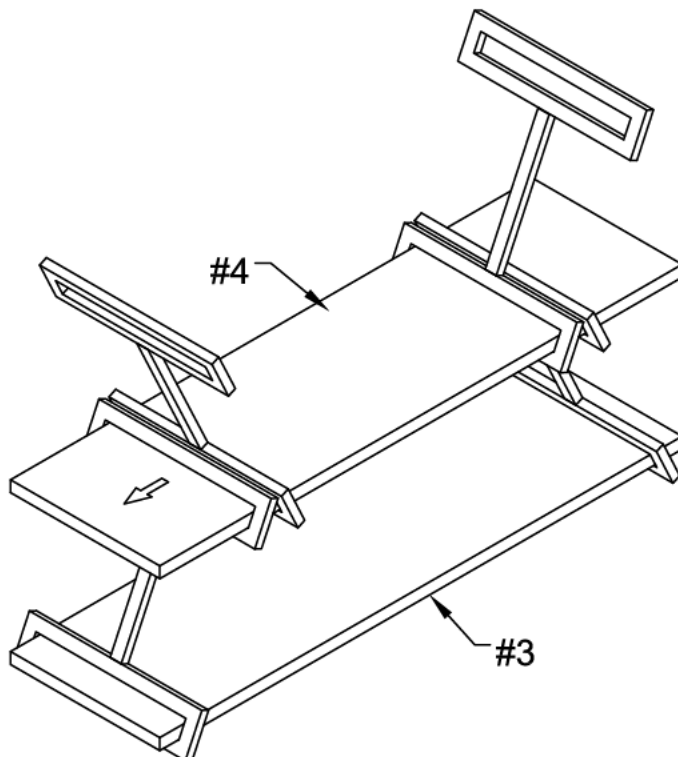

# ASSEMBLY INSTRUCTIONS

## 5

Part #4 x1pc

Insert the Upper board (#4) into connecting frames (#1), and adjust the position to align it with the other upper board (#4).

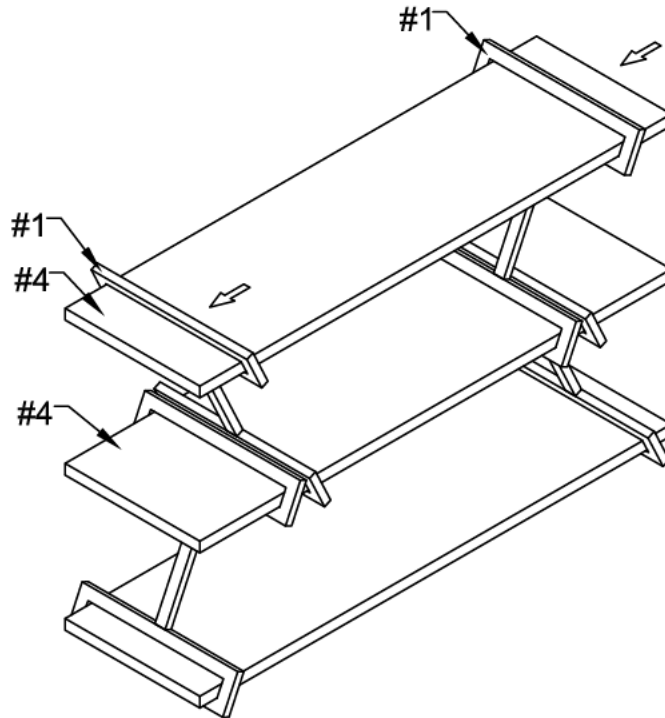

## 6

Part #1 x2pcs

Attach the connecting frames (#1) with the Upper board (#4).

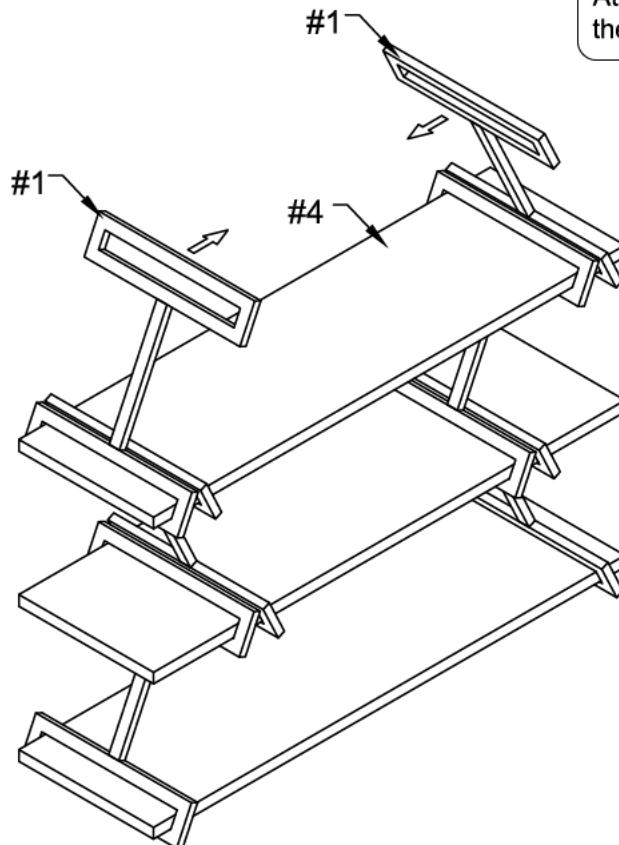

# ASSEMBLY INSTRUCTIONS

7

Part #4 x1pc

Insert the Upper board (#4) into connecting frames (#1)

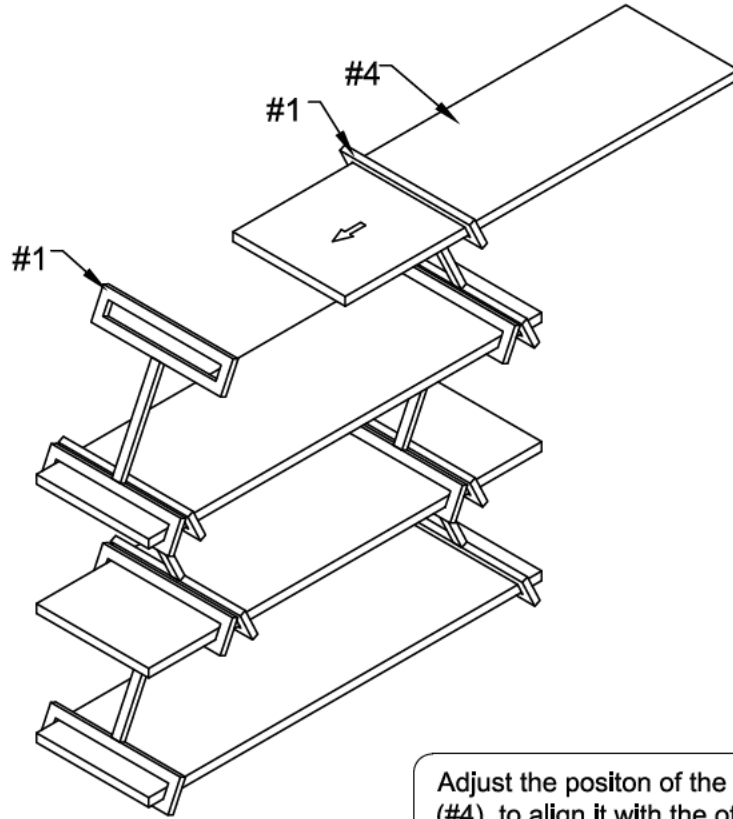

8

Adjust the position of the upper board (#4), to align it with the other upper board (#4).

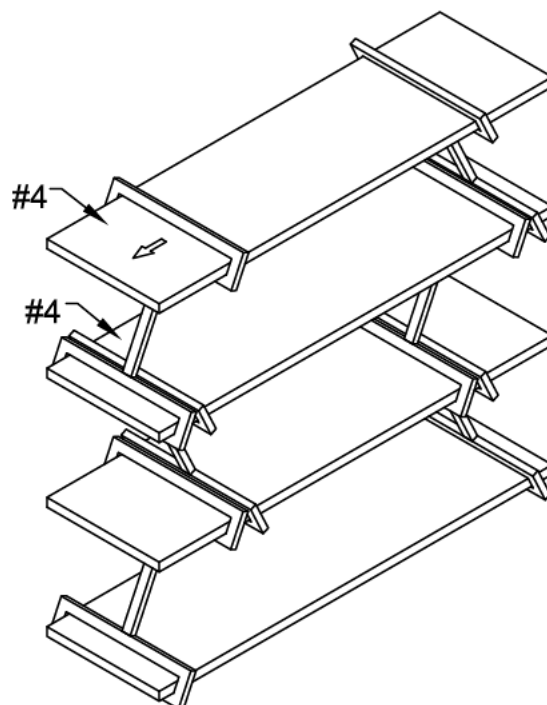

# ASSEMBLY INSTRUCTIONS

## 9

- Part #2 x1pc
- Hardware #A x3pcs
- Hardware #B x3pcs
- Hardware #F x1pc

Align the back circle frame (#2) to Upper board (#4), then secure by using screws (#A) with washers (#B).

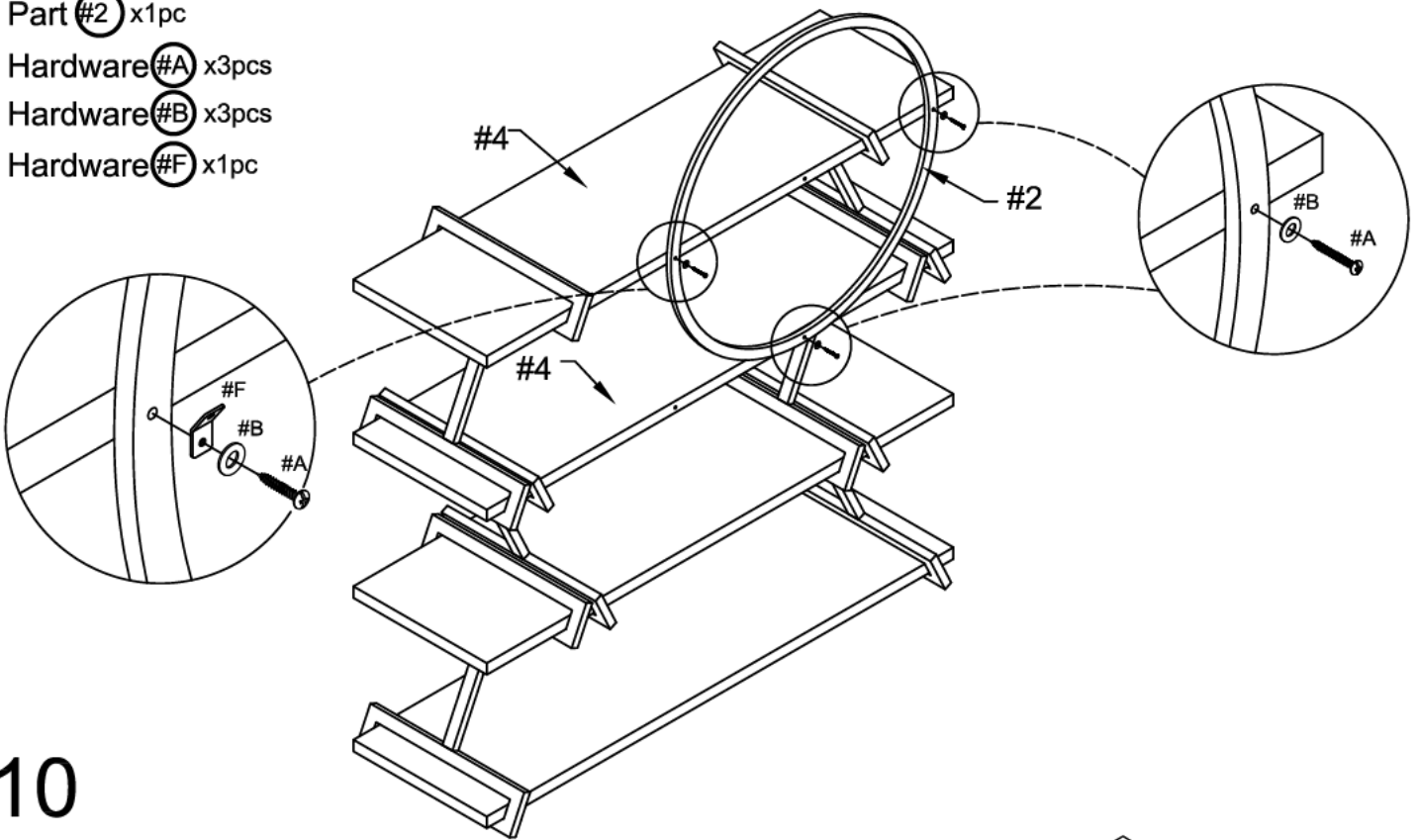

## 10

- Hardware #E x1pc
- Hardware #F x1pc

Locate the bracket (#F) on the wall over a wall stud and 2 inches below the bracket (#F) secured to the back of coat stand. Attach the wall stud using the screw (#E) provided, through the smaller hole.

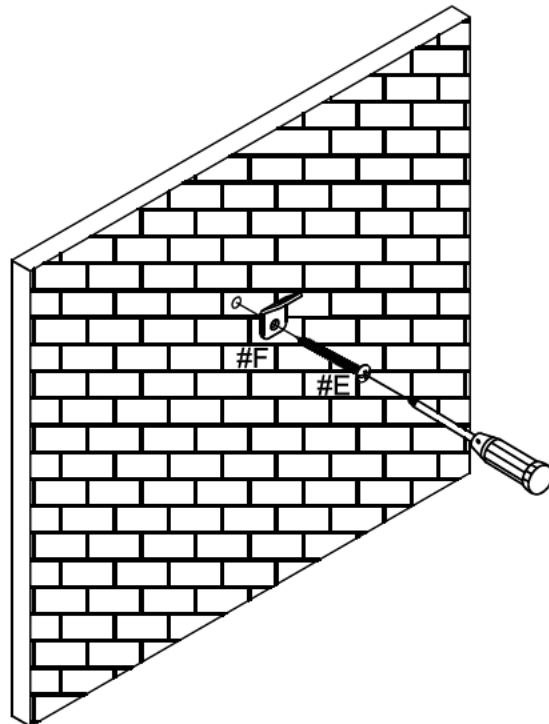

# ASSEMBLY INSTRUCTIONS

# 11

Hardware  x1pc

Place the furniture into position so both brackets (#F) are vertically in line. Lace the end of the restraint strap through the larger hole in each bracket (#F). Bring both ends together and slide the flat end through the locking end and draw it through until all slack is removed. Confirm that the strap is securely laced and locked.

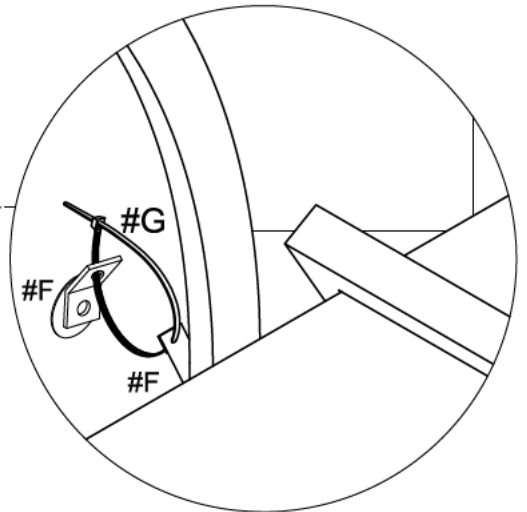
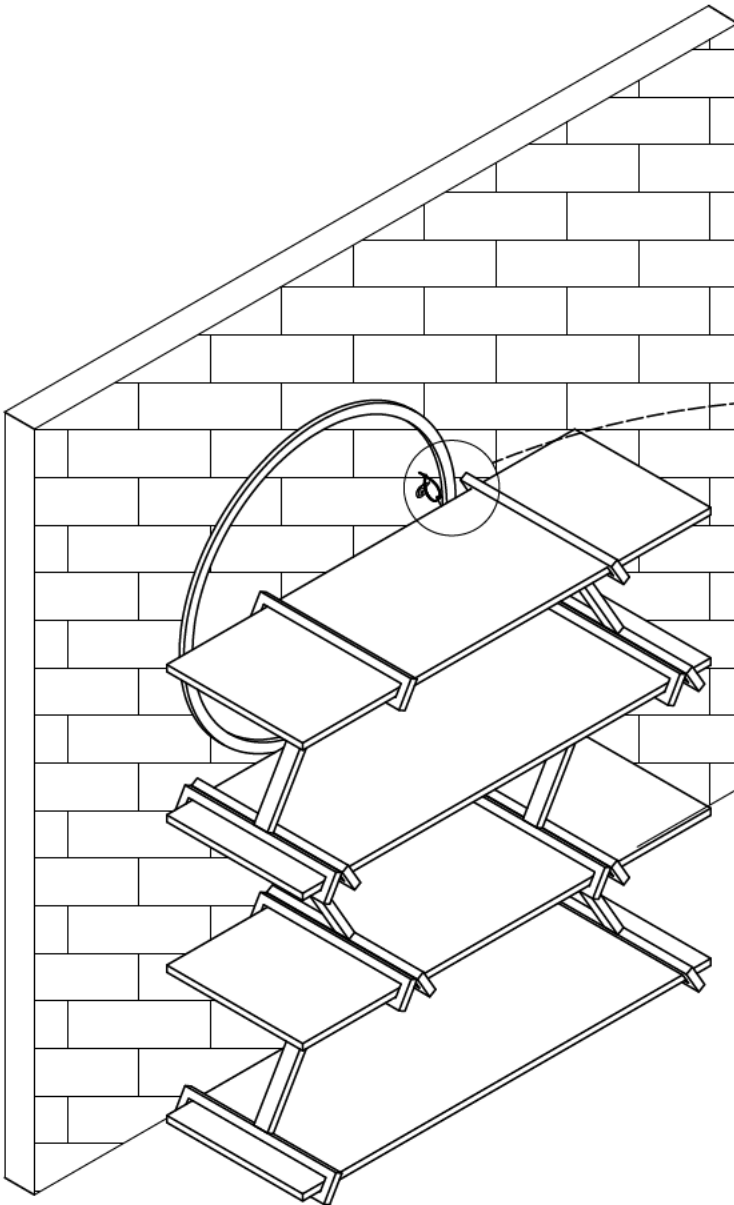

## ASSEMBLY COMPLETED



Please ensure the furniture rests on an even and flat surface. If the product wobbles or feels loose, double-check all bolts and/or screws are properly tightened and secured.

**TO PREVENT TIP OVER  
PRODUCT MUST BE  
ATTACHED TO WALL**



### Keep this handy!

Please retain this instruction manual and any order-related information for future reference.



### Lift, don't drag!

To avoid damage to product please always LIFT the product when transporting or adjusting the placement.

# ASSEMBLY INSTRUCTIONS

## Wall Mounting and Fixing



### EXPANSION WALL ANCHOR

Our provided expansion wall anchors are only suitable for masonry walls, such as drywall, plaster or concrete, and are best for holding lightweight items or for anti-tip prevention. If you are unsure of the correct wall anchor to use with the product, please request professional guidance. Liability for product damage or failure due to using the incorrect anchors will fall on the installer.

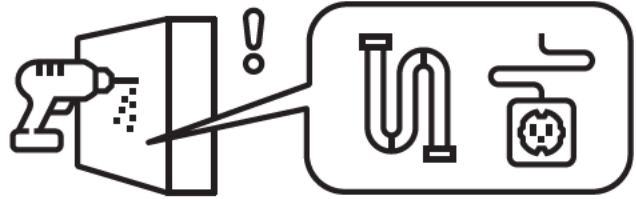

### CHECK BEFORE PROCEEDING

Prior to drilling or hammering, please check for wires or pipes. We recommend using a stud finder to locate a stud, which will offer more appropriate resistance and hold more weight.

## QUICK TIPS

1. If unsure of the proper size, always choose a larger screw and wall anchor.

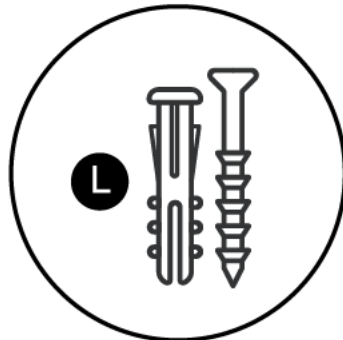

2. Match the drill bit to the wall anchor and hole size.

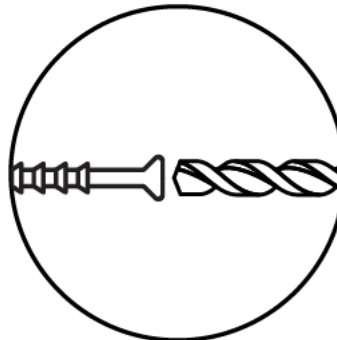

3. Only drill horizontally. Do not force the drill or enlarge the hole for the wall anchor.

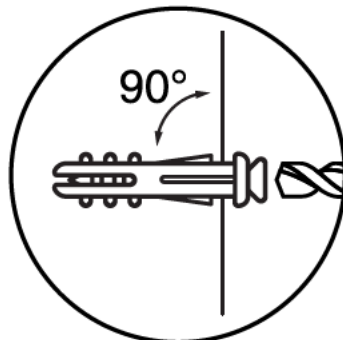

4. Take extra care when drilling into high walls or ceramic tiles. Wall anchors should be a tight fit for the hole. Never use wall anchors in ceilings.

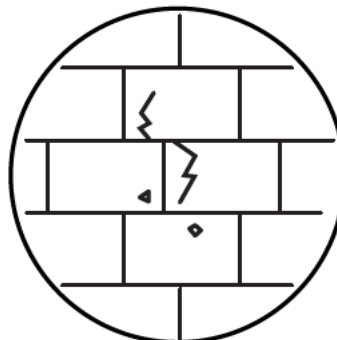

### MAINTENANCE



We recommend a yearly check to see if the wall anchor or screw has loosened. If so, please remove the existing wall anchor and screw, and use a new anchor.