

ASSEMBLY INSTRUCTIONS

TOOLS REQUIRED:

Allen key (supplied, part # G)

BEFORE YOU START:

1. Check the parts against the parts list to make sure all items are present.
2. Assemble your furniture on a soft, flat surface to avoid scratching the finish.
3. **CAUTION:** Do not over tighten screws, nuts or bolts during assembly.
4. Your furniture may require occasional tightening.

INSTRUCTIONS:

1. Carefully lay table top upside down on a flat, soft surface. Attach the post to the table frame. (see Figure 1)
2. Attach the post to the iron, using Bolt (D), Lock Washers (E) and Flat Washers (F). Tighten with Allen key (G). (see Figure 2).
3. Attach the iron to the table frame, using Bolt (A), Lock Washers (B) and Flat Washers (C). Tighten with Allen key (G). (see Figure 3).
4. Attach the base to the post, using Bolt (D), Lock Washers (E) and Flat Washers (F). Tighten with Allen key (G). (See Figure 4).

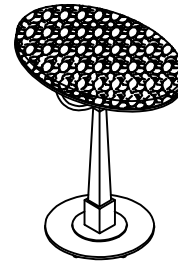

036-914

Figure 1

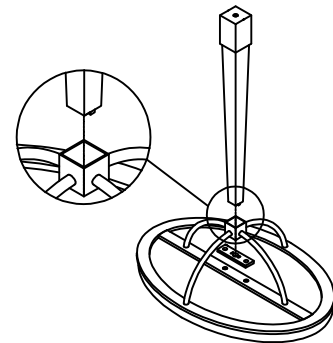

Figure 2

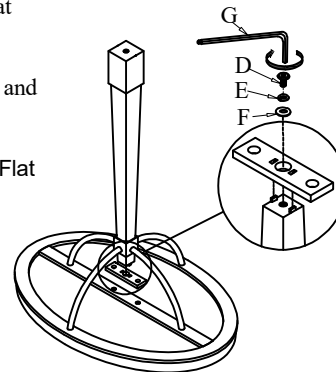
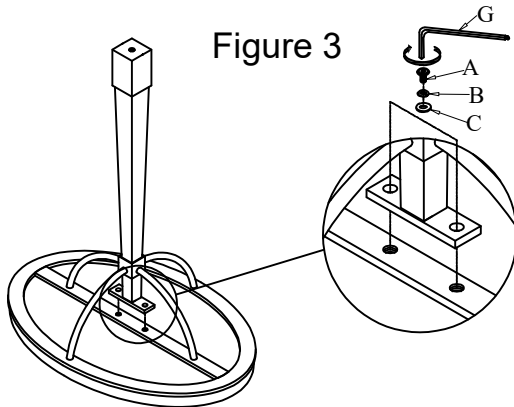









Figure 4



No.		Hardware List	Q'ty
A		Bolt Ø1/4xL5/8"	2
B		Lock Washer Ø1/4"xØ11x1mm	2
C		Flat Washer Ø1/4"xØ13x1mm	2
D		Bolt Ø5/16xL1"	2
E		Lock Washer Ø5/16xØ14x1mm	2
F		Flat Washer Ø5/16xØ18x1mm	2
G		Allen Key 4mm	1