

# **ASSEMBLY INSTRUCTIONS**

**ASSEMBLY TIPS:**







1. Remove hardware from box and sort by size
2. Please check to see that all hardware and parts are present prior to start of assembly.
3. Please follow attached instruction in the same sequence as numbered to assure fast & easy assembly.









**Warning!**

1. Don't attempt to repair or modify parts that are broken or defective. Please contact the store immediately.
2. This product is for home use only and not intended for commercial establishment

**PARTS IDENTIFICATION**

<b>A</b>		CHAIR BACK	2PCS
<b>B</b>		CUSHION SEAT WITH FRAME	2PCS
<b>C</b>		LEFT FRONT LEG	2PCS
<b>D</b>		RIGHT FRONT LEG	2PCS
<b>E</b>		RIGHT SIDE STRETCHER	2PCS
<b>F</b>		LEFT SIDE STRETCHER	2PCS
<b>G</b>		FRONT STRETCHER	2PCS

**HARDWARE IDENTIFICATION**

<b>1</b>		LONG BOLT	8PCS
<b>2</b>		MEDIUM BOLT	8PCS
<b>3</b>		SHORT BOLT	2PCS
<b>4</b>		LOCK WASHER	18PCS
<b>5</b>		FLAT WASHER	18PCS
<b>6</b>		ALLEN WENCH	2PCS
<b>7</b>		SCREW	12PCS

**NOTE : QUANTITIES SHOWN ARE FOR TWO CHAIRS**

**STEP 1**

- 1.1 Align & hand tighten cushion seat with frame to chair back bottom rail using short bolt, lock washer & flat washer.
- 1.2 Align & hand tighten cushion seat with frame to chair back leg using long bolt, lock washer & flat washer.
- 1.3 Tighten all bolts with Allen wrench.
- 1.4 Insert left and right side stretchers to chair back legs.

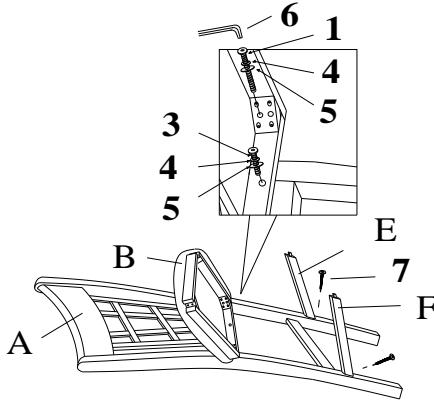

**STEP 2**

- 2.1 Insert front, left & right side stretchers to left and right front legs.
- 2.2 Then align & fasten left and right front legs to cushion seat with frame using medium bolt, lock washer & flat washer. TIGHTEN WITH ALLEN WRENCH.
- 2.3 Fasten front, left & right side stretchers to back, left & right front legs using screw. TIGHTEN WITH SCREW DRIVER ( NOT INCLUDED ).

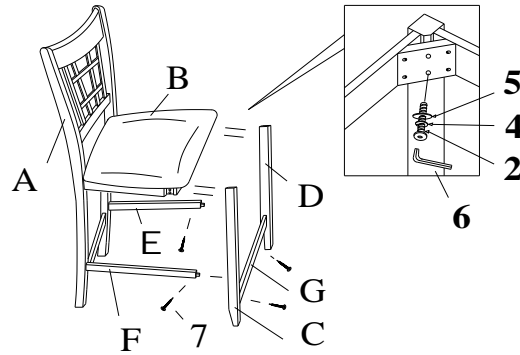

**STEP 3**

Complete.

