







# OFFICE CHAIR

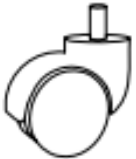
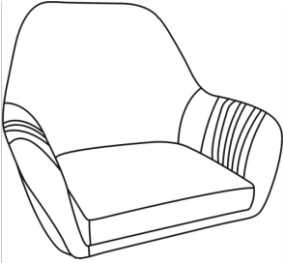

## ASSEMBLY INSTRUCTIONS

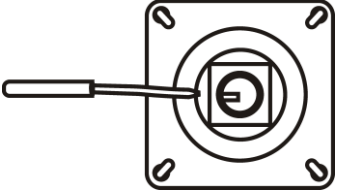
1	2	3
 <p data-bbox="233 954 379 1025"><b>GAS LIFT</b> 1PC</p>	 <p data-bbox="687 954 911 1025"><b>SWIVEL BASE</b> 1PC</p>	 <p data-bbox="1222 954 1350 1025"><b>CASTER</b> 5PCS</p>
4	5	6
 <p data-bbox="268 1458 360 1529"><b>SEAT</b> 1PC</p>	 <p data-bbox="715 1458 880 1529"><b>BASE CAP</b> 1PC</p>	 <p data-bbox="1123 1458 1461 1529"><b>BRACKET W/HANDLE</b> 1PC</p>
A	B	
 <p data-bbox="201 1962 424 2033"><b>BOLT M6X1/2"</b> 4PCS</p>	 <p data-bbox="743 1962 887 2033"><b>WRENCH</b> 1PC</p>	

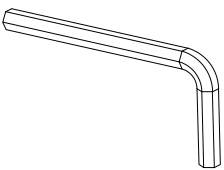
## STEP 1

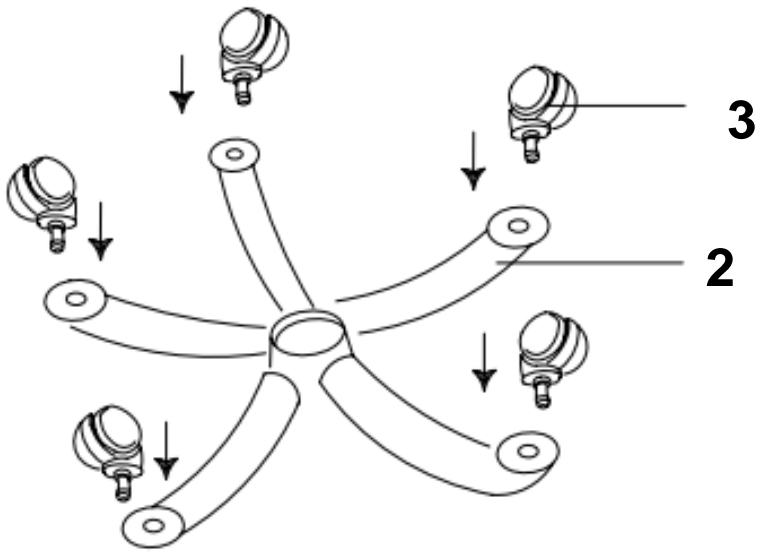

\*Please put all parts on a soft surface to prevent scratches.

Insert Caster (3) into Swivel Base (2) carefully as shown.

## STEP 2

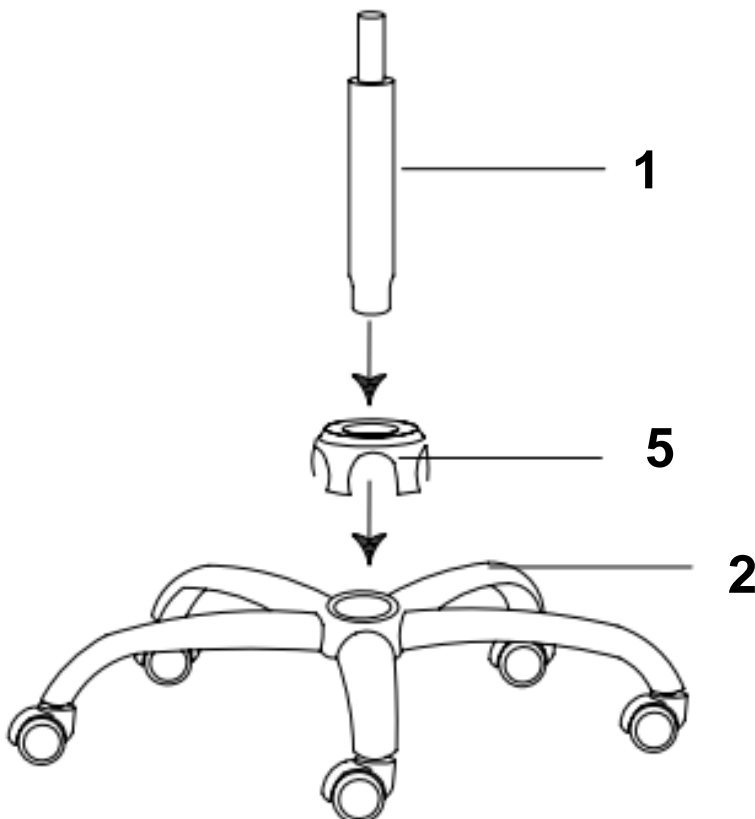

Insert Base cap (5) and Gas lift (1) into Swivel Base (2) carefully as shown.

### STEP 3

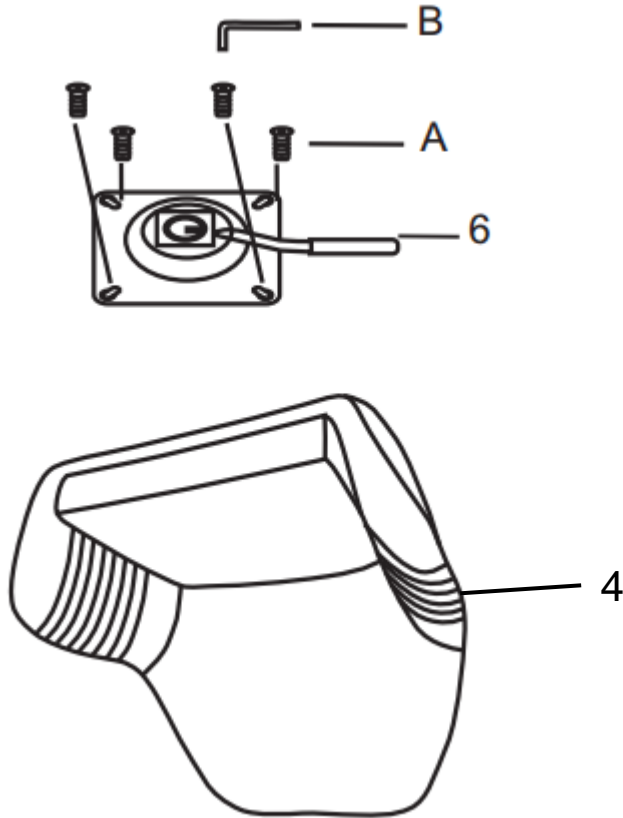

Attach Bracket w/Handle (6) to seat (4) by using bolt (A) and Wrench (B) as shown.

Tighten all bolts firmly!

### STEP 4

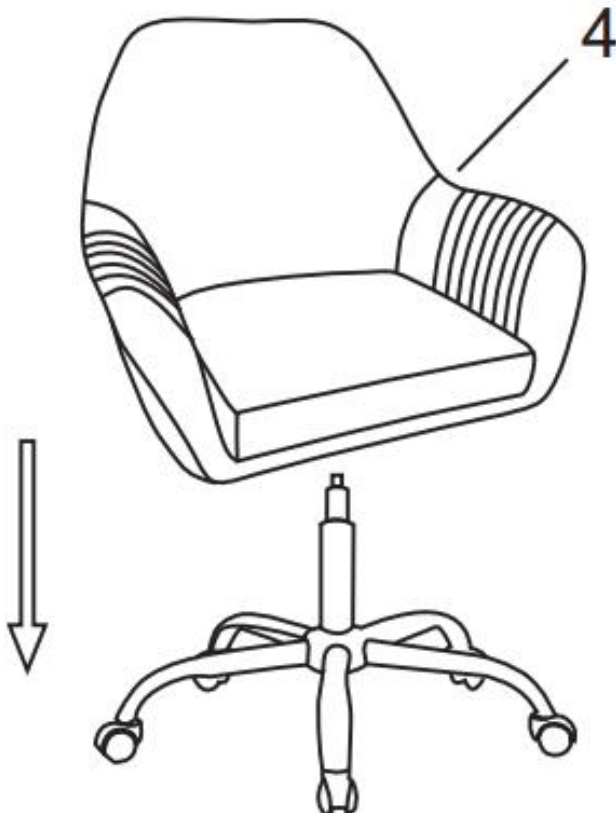

Insert Gas lift (1) into seat (4) by applying moderate downwards force to the seat (4) in order to secure it to the base as shown. Your perfect chair is completed.