

Office Chair











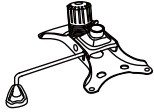

Installation Instruction

Thank you very much for buying office chair this time. In order to use this product safely, please be sure to read this "Installation instruction" carefully.

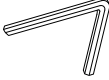

Installation Instruction

Note: Gloves are recommended to avoid injury during assembly

<p>A</p> 	<p>B</p> 	<p>C</p> 	<p>D</p> 	<p>E</p> 	<p>F</p> 	<p>G</p> 	<p>Hx8</p> 	<p>Ix8</p>  <p>M6X25mm</p>
<p>J</p> 		<p>Kx5</p>  <p>M6X16mm</p>	<p>Lx4</p>  <p>M6X20mm</p>					

ATTENTION:

Please make sure all the accessories are taken out from the backrest before installation, sand zip up carefully to avoid being stuck.

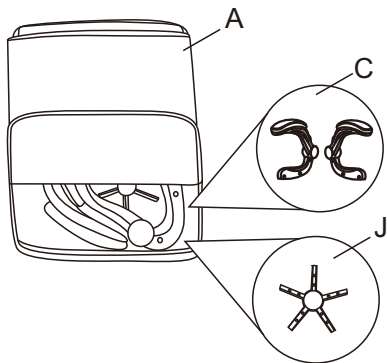

J1

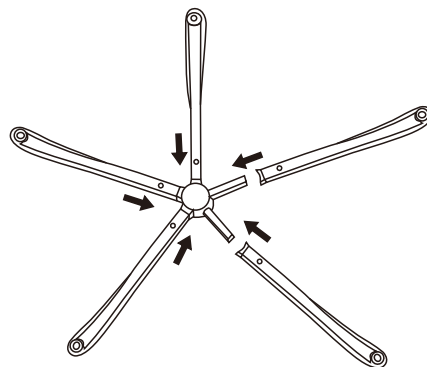

J2

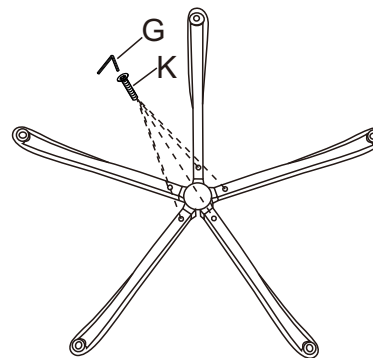

J3

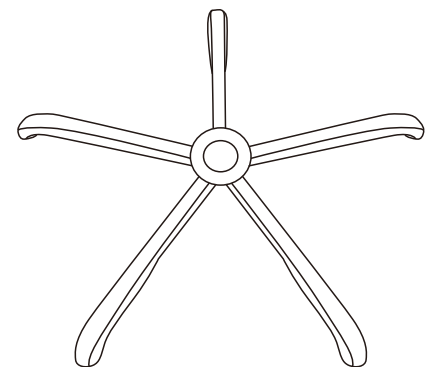

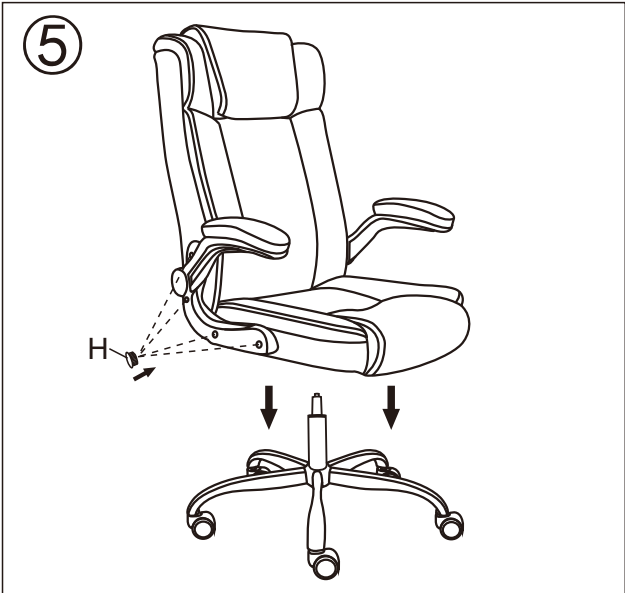
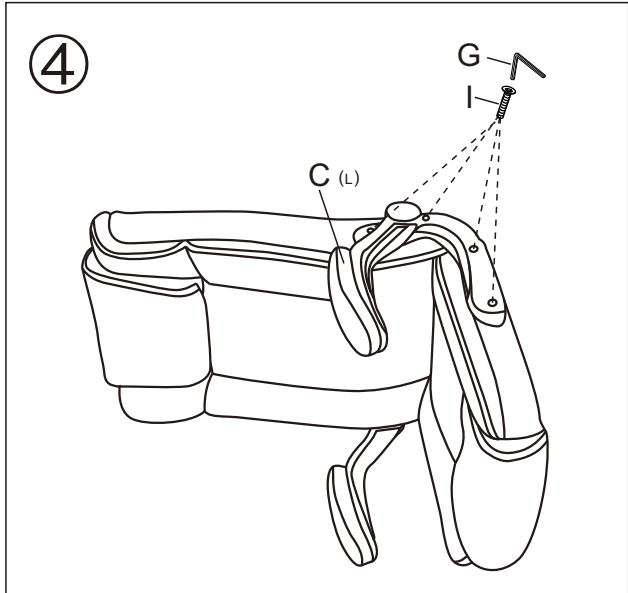
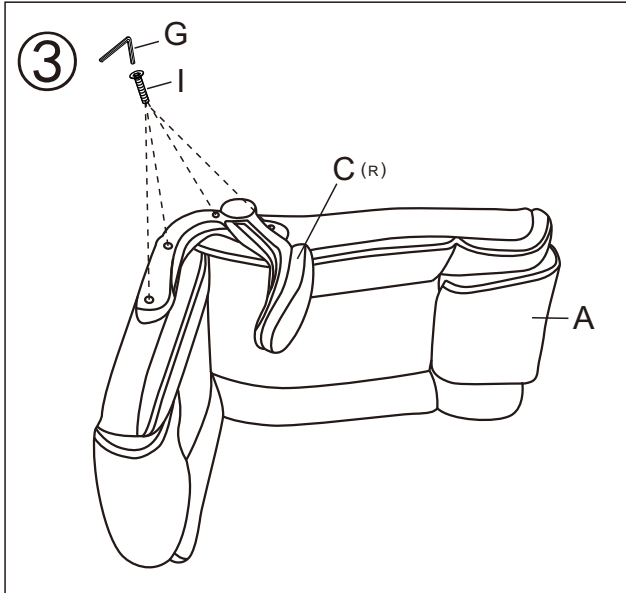
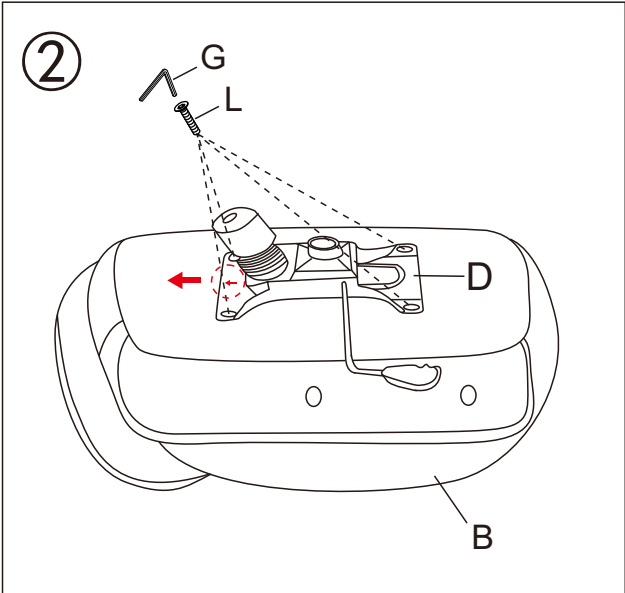
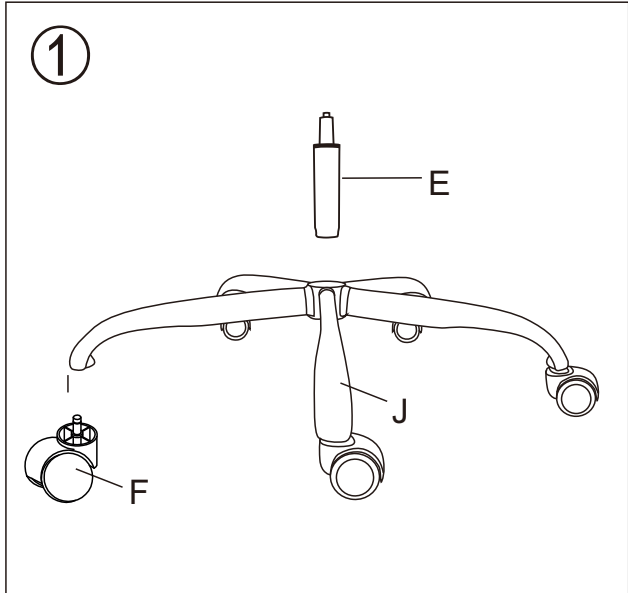

You have worked hard. Reward yourself for your efforts! Experience it now!

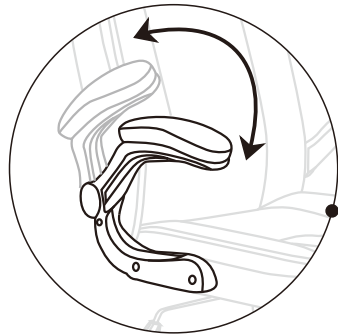

Armrest function:

The armrest can be moved for 90 degrees.

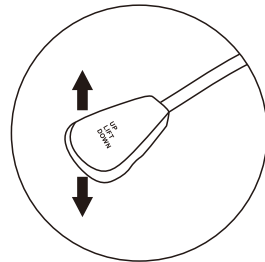

Adjustable Height:

Press the handle on the right side of the seat, you can adjust the chair height



Swiveling:

Can swivel and stop at any position.

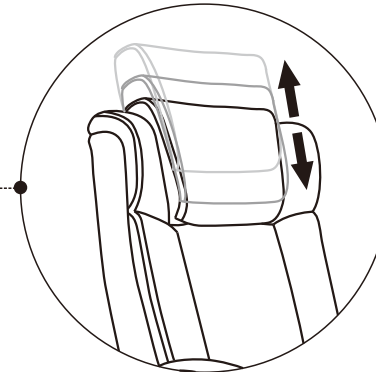

Headrest function:

The headrest can be adjusted from top to bottom, and stop at any position

▲ Precautions in use ▲

- Avoid direct sunlight or high temperature, damp and dry places
- Do not use on floors that slide easily
- It is recommended to retighten bolts and screws periodically on a two-month basis
- Please do not use in the state of loose bolts or screws.
- Please be careful not to let the moving parts of the hands and feet, etc.
- To remove significant dirt, use a diluted neutral detergent.
- Please do not sit hard on your seat. If you sit too hard, you will bear many times the load, which may break the chair.
- Please do not sit more than two people at a time
- Do not use push rods including adjusting bolts, screws, etc. if even one of them is lost, damaged or consumed, only until the correct parts are repaired
- ※ If the above points are not used, there may be a big accident, please be sure to comply with them.

Installationsanleitung











Vielen Dank, dass Sie diesen Bürostuhl gekauft haben. Um dieses Produkt sicher zu verwenden, lesen Sie bitte diese "Installationsanleitung sorgfältig durch".

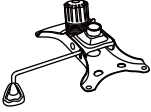

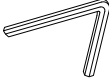
Installationsanleitung

P.4.2

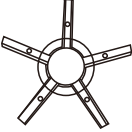
Hinweis: Es wird empfohlen, Handschuhe zu tragen, um Verletzungen während der Montage zu vermeiden.

A 	B 	C 	D 	E 	F 	G 	Hx8 	Ix8  M6X25mm	
J 		Kx5 	Lx4  M6X16mm			 M6X20mm			

ACHTUNG:

Bitte stellen Sie sicher, dass vor der Installation alle Zubehörteile aus der Rückenlehne entfernt werden, und schließen Sie den Reißverschluss vorsichtig, um ein Verklemmen zu vermeiden.

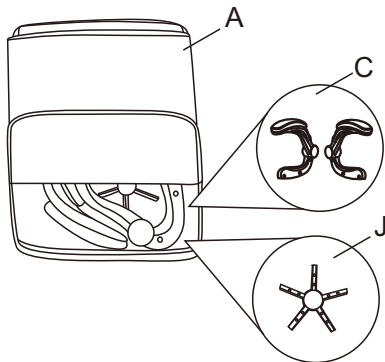

J1

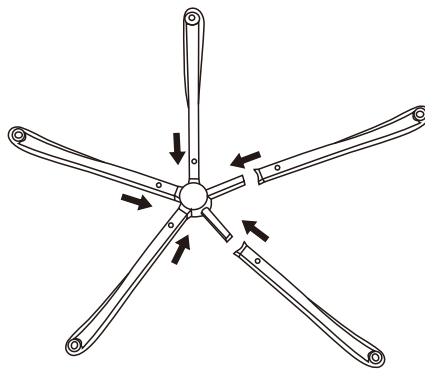

J2

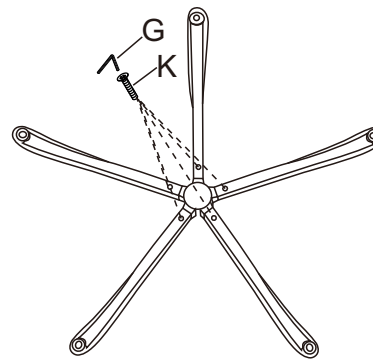

J3

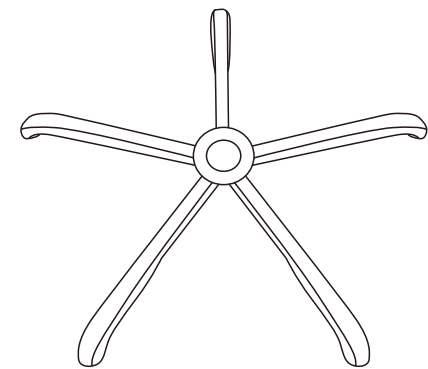

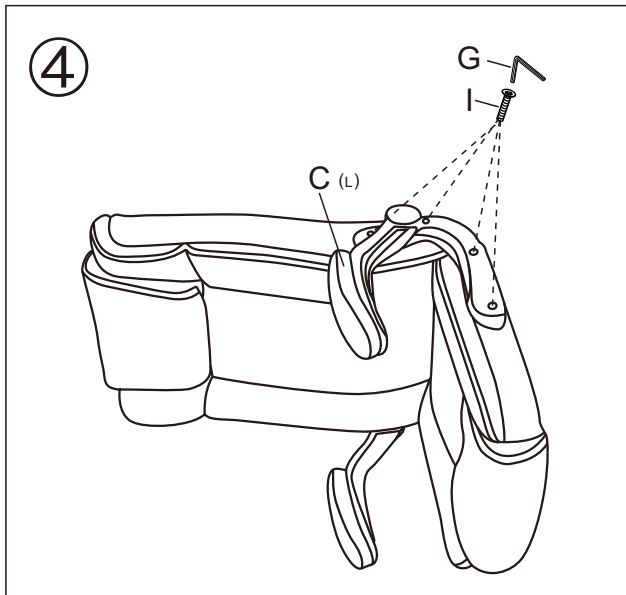
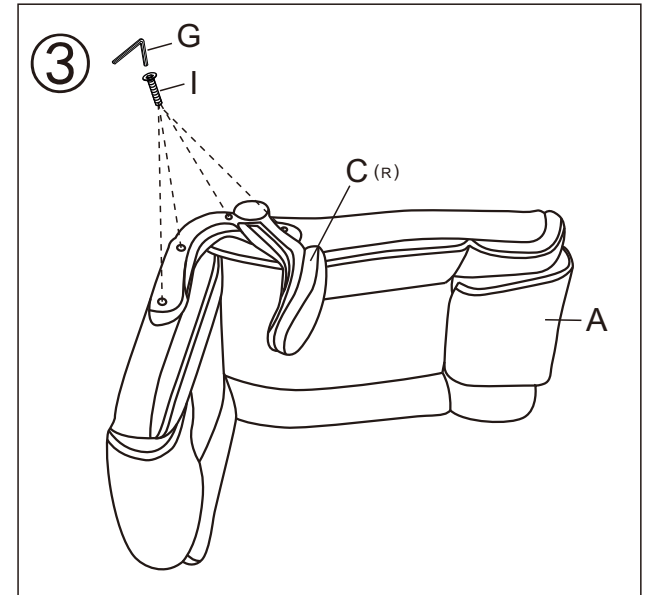
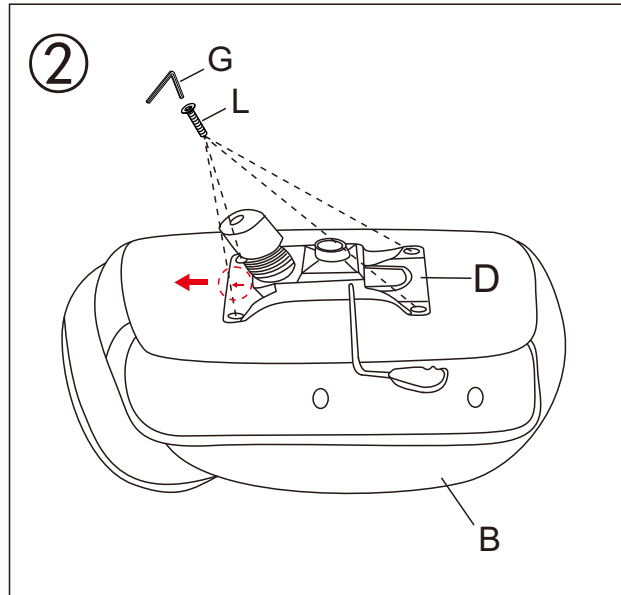
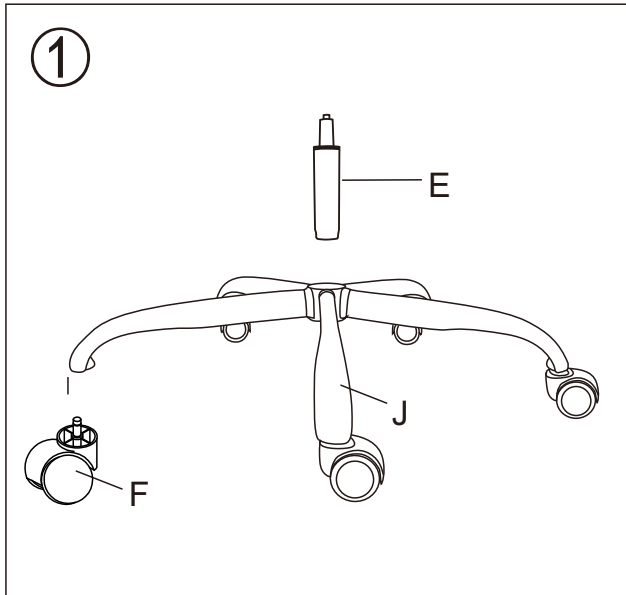

Sie haben hart gearbeitet. Belohnen Sie sich für Ihre Bemühungen! Erleben Sie es jetzt!

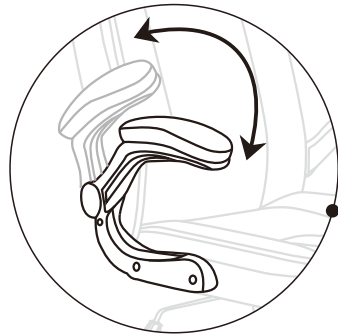

Armlehnenfunktion:

Die Armlehne kann um 90 Grad bewegt werden.

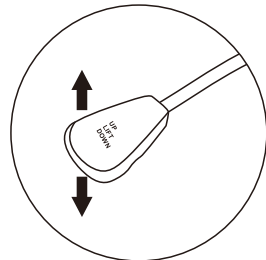

Höhenverstellung:

Drücken Sie den Griff auf der rechten Seite des Sitzes, um die Höhe des Stuhls zu verstellen.



Kopfstützenfunktion:

Die Kopfstütze kann von oben nach unten verstellt werden und in jeder Position stoppen.

Drehfunktion:

Der Stuhl kann sich drehen und in jeder Position stoppen.

Vorsichtsmaßnahmen bei der Verwendung

- Vermeiden Sie direkte Sonneneinstrahlung oder hohe Temperaturen, feuchte und trockene Orte.
- Nicht auf Böden verwenden, die leicht rutschen.
- Es wird empfohlen, die Bolzen und Schrauben regelmäßig alle zwei Monate nachzuziehen.
- Achten Sie bitte darauf, dass die beweglichen Teile der Hände und Füße usw. nicht beschädigt werden.
- Verwenden Sie zum Entfernen von starkem Schmutz ein verdünntes neutrales Reinigungsmittel.
- Bitte setzen Sie sich nicht zu hart auf Ihren Sitz. Wenn Sie zu hart sitzen, tragen Sie ein Vielfaches der Last, was zum Bruch des Stuhls führen kann.
- Bitte sitzen Sie nicht mehr als zwei Personen auf einmal
- Benutzen Sie die Schubstangen einschließlich der Einstellbolzen, Schrauben usw. nicht, wenn auch nur eine davon verloren gegangen, beschädigt oder verbraucht ist, sondern nur so lange, bis die richtigen Teile repariert sind.
- ※ Wenn die oben genannten Punkte nicht beachtet werden, kann es zu einem großen Unfall kommen, bitte halten Sie sich unbedingt daran.

Instructions d'installation









Merci beaucoup d'avoir acheté ce fauteuil de bureau. Pour utiliser ce produit en toute sécurité, veuillez lire attentivement ces "instructions d'installation".

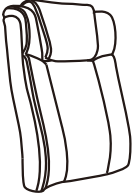

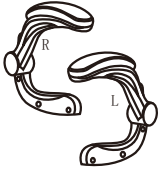
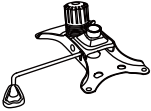
Instructions d'installation

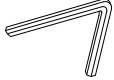
P.4.2

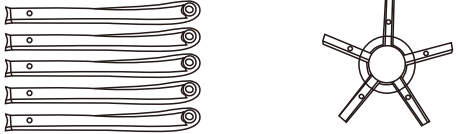
Remarque : Il est recommandé de porter des gants pour éviter les blessures pendant l'assemblage.

<p>A</p> 	<p>B</p> 	<p>C</p> 	<p>D</p> 	<p>E</p> 	<p>F</p> 	<p>G</p> 	<p>Hx8</p> 	<p>Ix8</p>  <p>M6X25mm</p>
<p>J</p> 		<p>Kx5</p>  <p>M6X16mm</p>	<p>Lx4</p>  <p>M6X20mm</p>					

ATTENTION:

Assurez-vous que tous les accessoires ont été retirés du dossier avant l'installation, et fermez soigneusement la fermeture éclair pour éviter de rester coincé.

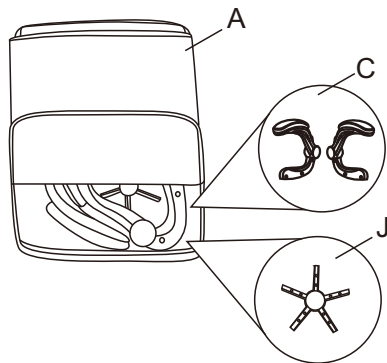

J1

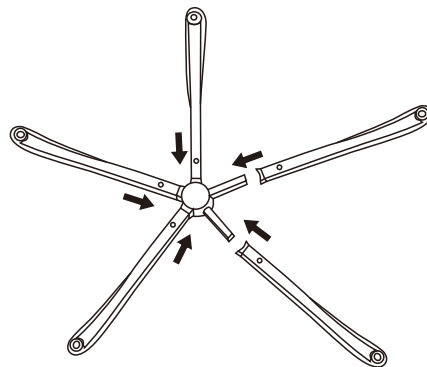

J2

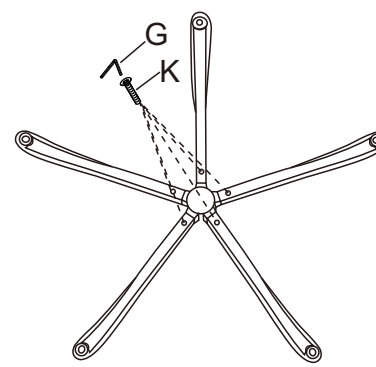

J3

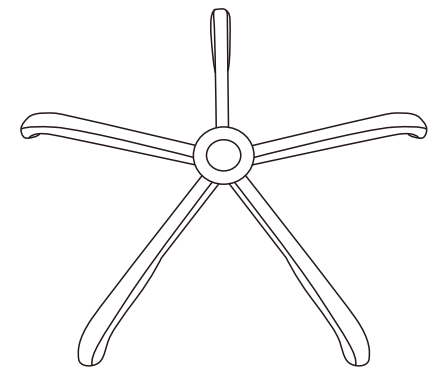

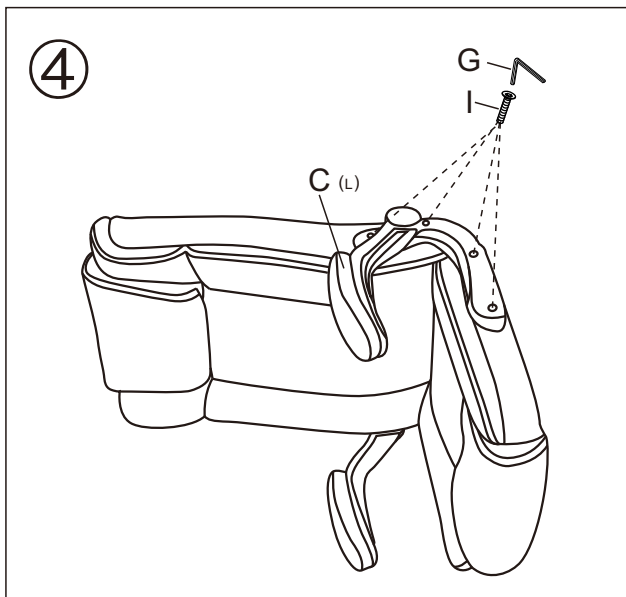
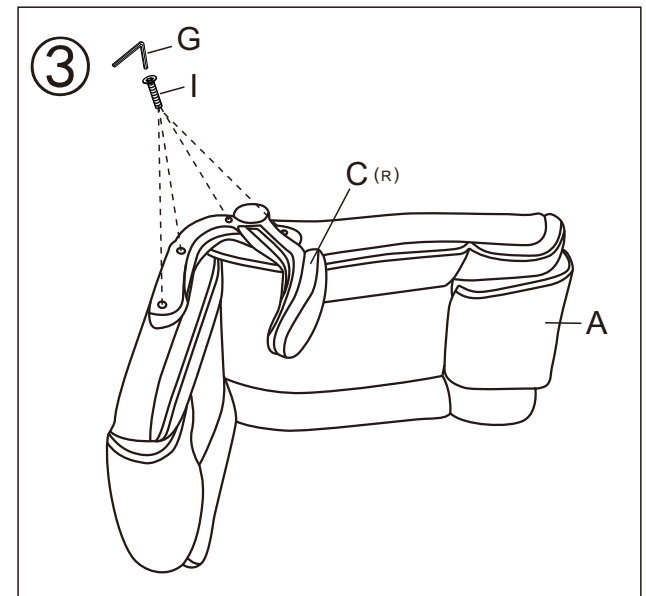
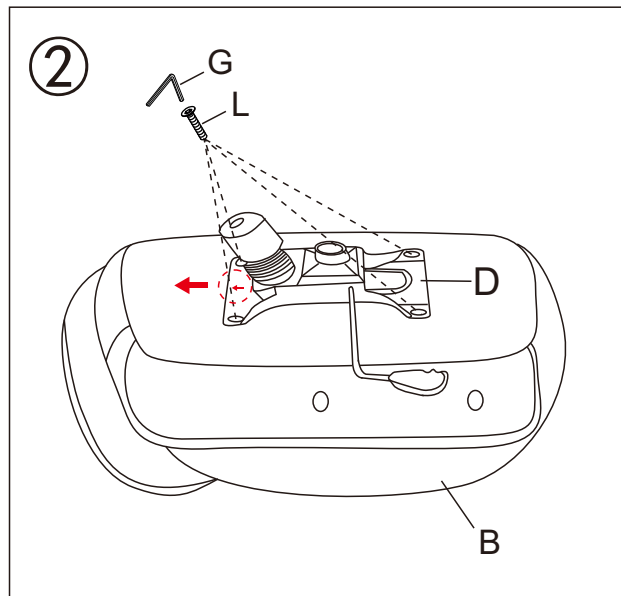
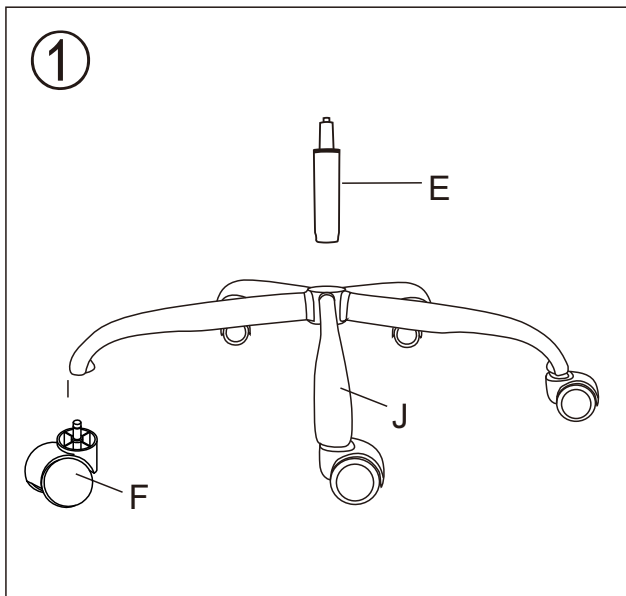

Vous avez bien travaillé. Récompensez-vous pour vos efforts ! Profitez-en maintenant !

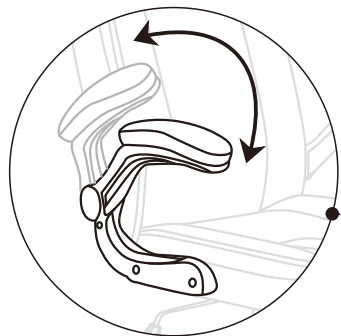

Fonction des accoudoirs :

Les accoudoirs peuvent être déplacés de 90 degrés.

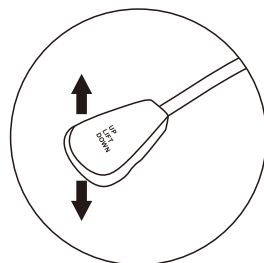

Hauteur réglable :

Appuyez sur la poignée du côté droit du siège pour ajuster la hauteur du fauteuil.

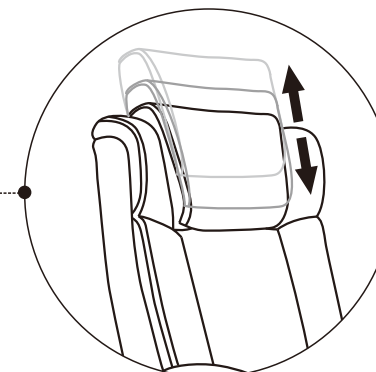
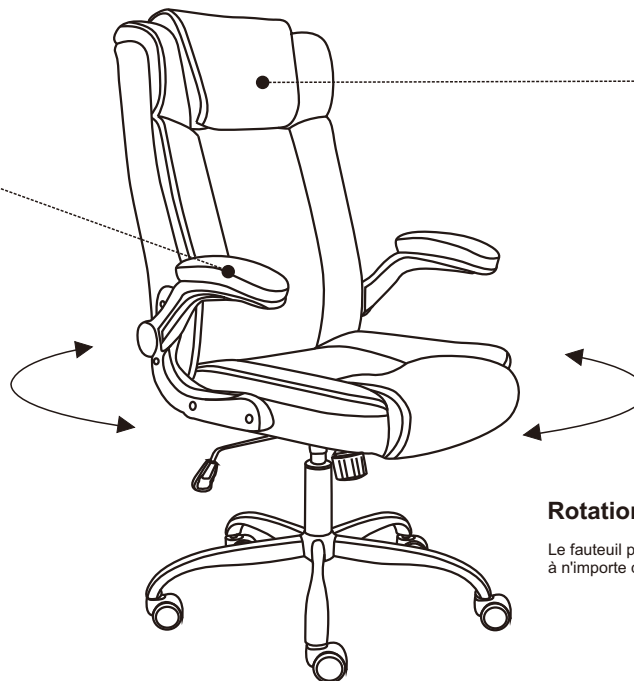

Fonction de l'appuie-tête :

L'appuie-tête peut être ajusté de haut en bas et s'arrêter à n'importe quelle position.

Rotation :

Le fauteuil peut pivoter et s'arrêter à n'importe quelle position.

⚠ Précautions d'emploi ⚠

- Évitez la lumière directe du soleil ou les températures élevées, les endroits humides et secs.
- Ne pas utiliser sur des sols qui glissent facilement.
- Il est recommandé de resserrer les boulons et les vis périodiquement sur une base de deux mois.
- Veuillez ne pas utiliser à l'état de boulons ou de vis desserrés, etc.
- Utilisez un détergent neutre dilué pour éliminer la saleté importante.

- S'il vous plaît, ne vous asseyez pas sur votre siège. Si vous vous asseyez trop fort, vous porterez plusieurs fois la charge, ce qui peut casser la chaise.
 - Veuillez ne pas vous asseoir plus de deux personnes à la fois.
 - N'utilisez pas de tiges de poussée, y compris les boulons de réglage, les vis, les vis, etc. si même l'un d'entre eux est perdu, endommagé ou consommé, seulement jusqu'à ce que les
 - ※ bonnes pièces soient réparées.
- Si les points ci-dessus ne sont pas utilisés, il peut y avoir un gros accident, assurez-vous de les respecter.

Instrucciones de instalación









Muchas gracias por comprar esta silla de oficina. Para usar este producto de manera segura, lea atentamente estas "instrucciones de instalación".

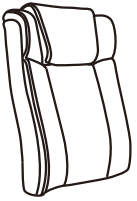

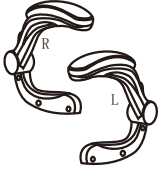
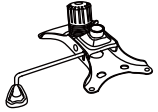
Instrucciones de instalación

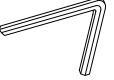
P.4.2

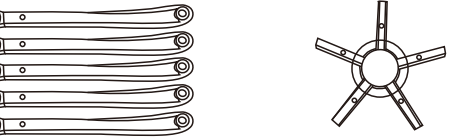
Nota: Se recomienda usar guantes para evitar lesiones durante el montaje.

A 	B 	C 	D 	E 	F 	G 	Hx8 	Ix8  M6X25mm
J 		Kx5  M6X16mm			Lx4  M6X20mm			

ATENCIÓN:

Por favor, asegúrese de que todos los accesorios se hayan retirado del respaldo antes de la instalación, y cierre la cremallera con cuidado para evitar que se atasque.

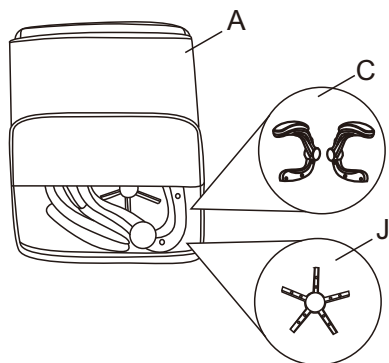

J1

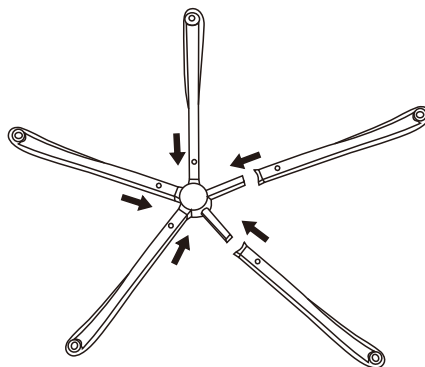

J2

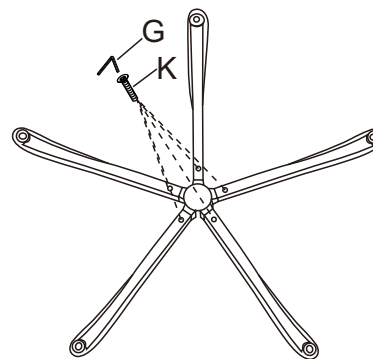

J3

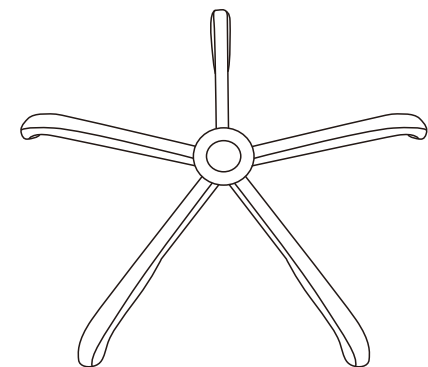

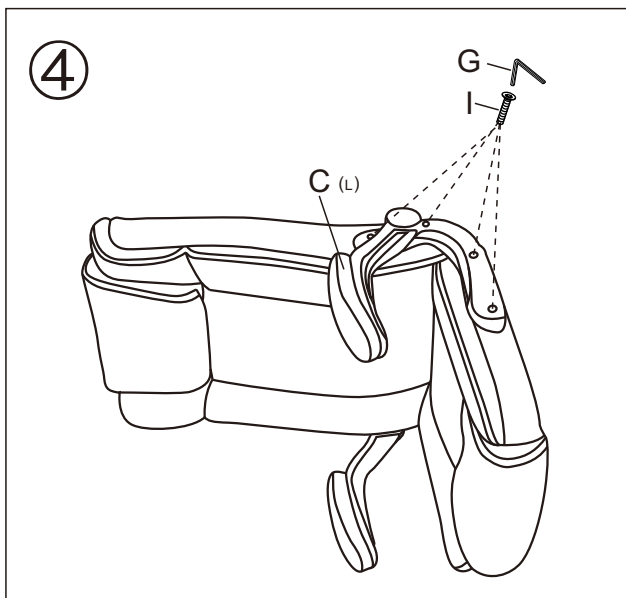
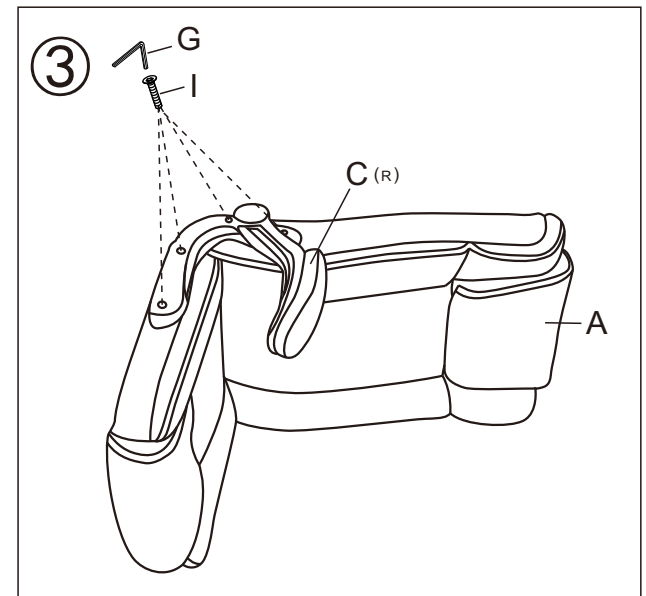
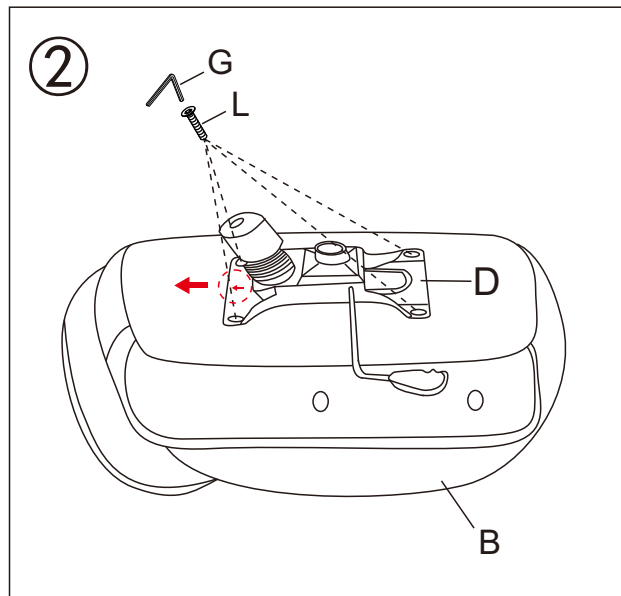
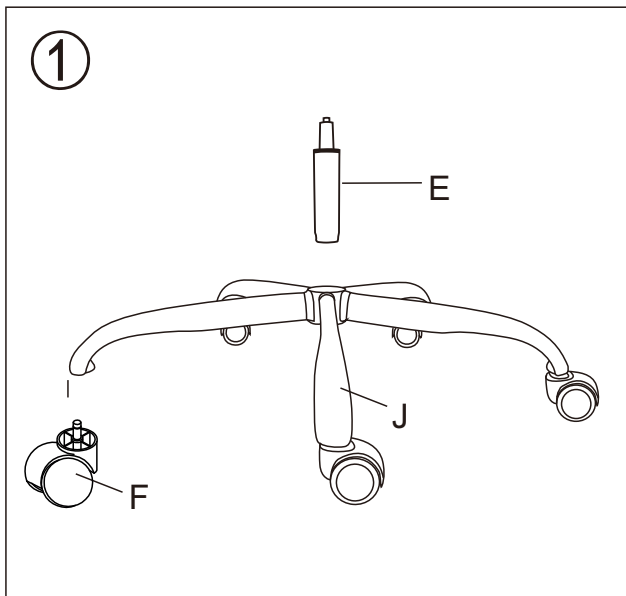

Ha trabajado duro. Recompénsate por tu esfuerzo. ¡Experimentélo ahora!

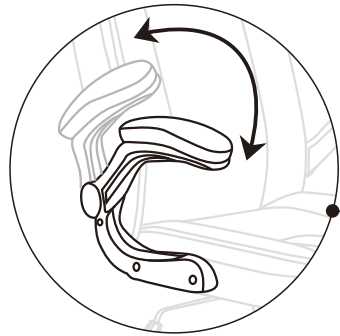

Función del reposabrazos:

El reposabrazos se puede mover 90 grados.

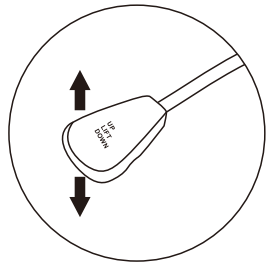

Altura ajustable:

Presione la manija en el lado derecho del asiento para ajustar la altura de la silla.

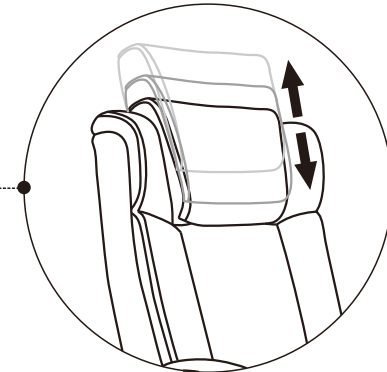

Función del reposacabezas:

El reposacabezas se puede ajustar de arriba hacia abajo y detenerse en cualquier posición.

Giro:

La silla puede girar y detenerse en cualquier posición.

▲ Precaución del uso ▲

- Evite la luz solar directa o altas temperaturas, lugares húmedos y secos.
- No lo use en suelos que se deslicen fácilmente.
- Se recomienda volver a apretar los pernos y tornillos periódicamente cada dos meses.
- No lo use en el estado de pernos o tornillos sueltos.
- Tenga cuidado de no dejar las partes móviles de las manos y los pies, etc.
- Para eliminar la suciedad significativa, utilice un detergente neutro diluido.
- No se sienta fuerte en su asiento. Si se sienta demasiado fuerte, soportará muchas veces la carga, lo que puede romper la silla.
- No se sienta más de dos personas a la vez.
- No use varillas de empuje, incluidos pernos de ajuste, tornillos, etc. Si uno de ellos se pierde, daña o consume, solo hasta que se reparen las piezas correctas.
- ※ Si no se usan los puntos anteriores, puede haber un gran accidente, asegúrese de cumplir con ellos..

Istruzioni di installazione

Grazie mille per aver acquistato questa sedia da ufficio. Per utilizzare questo prodotto in sicurezza, leggere attentamente queste "istruzioni di installazione".



Istruzioni di installazione

P.4.2

Nota: Si consiglia di indossare guanti per evitare infortuni durante il montaggio.

A	B	C	D	E	F	G	Hx8	Ix8
J	Kx5			Lx4				

ATTENZIONE

Prima di procedere all'installazione, assicurarsi che tutti gli accessori vengano rimossi dallo schienale prima dell'installazione e chiudere accuratamente la zip per evitare di rimanere bloccati.

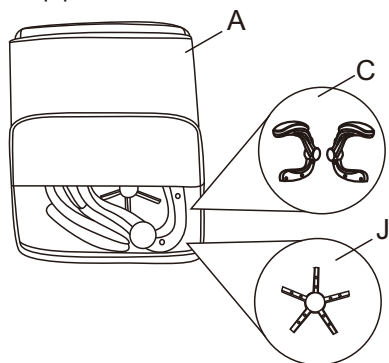

J1

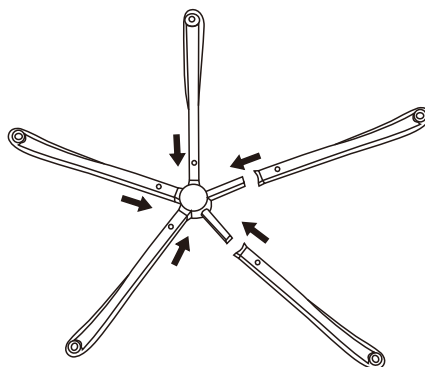

J2

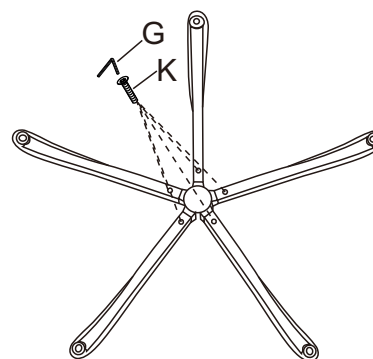

J3

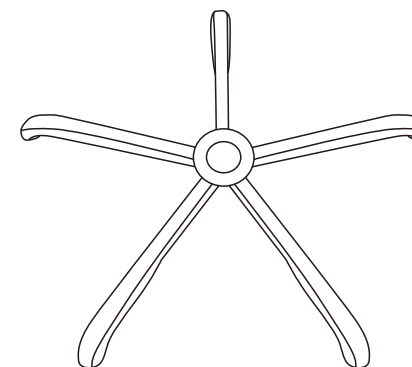

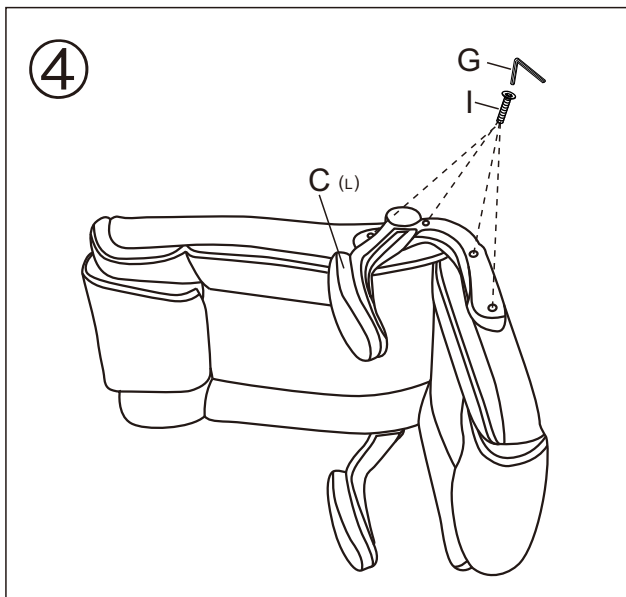
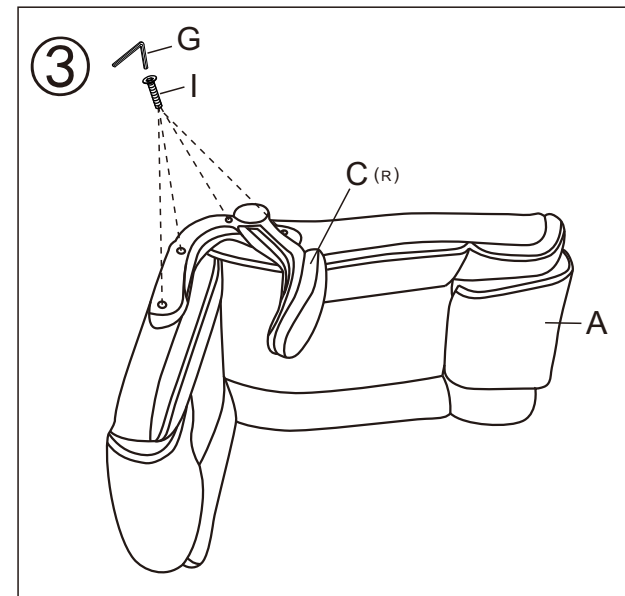
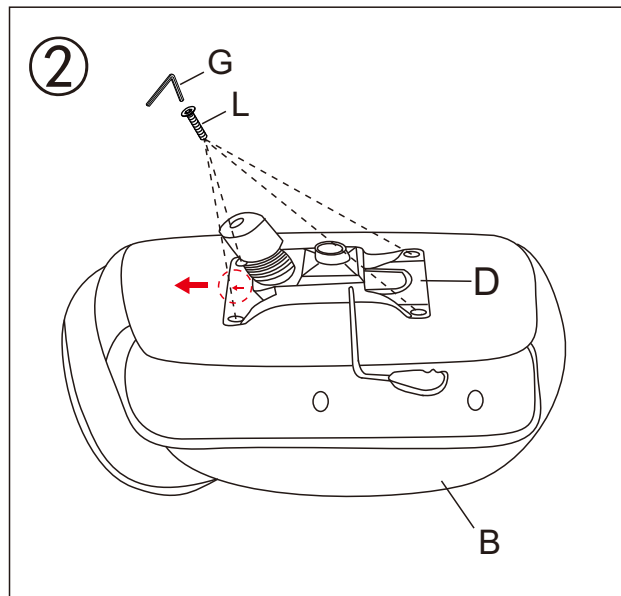
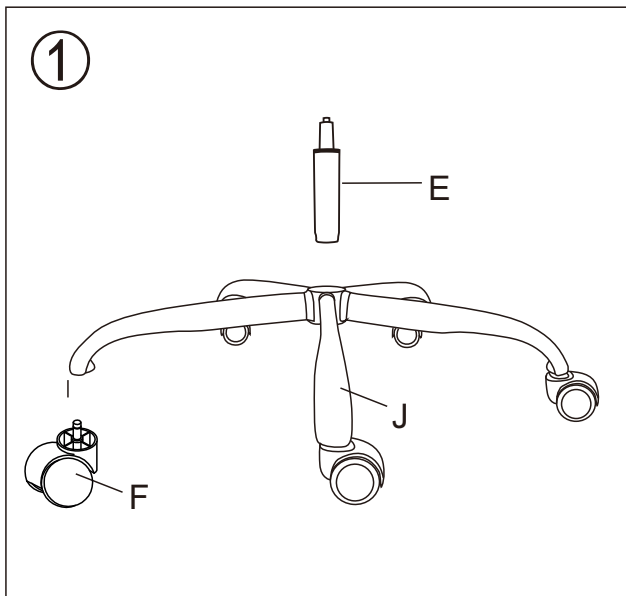

Avete lavorato sodo. Premiatevi per i vostri sforzi! Vivete l'esperienza ora!

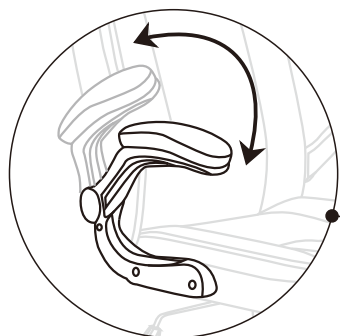

Funzione del bracciolo:

Il bracciolo può essere spostato di 90 gradi.

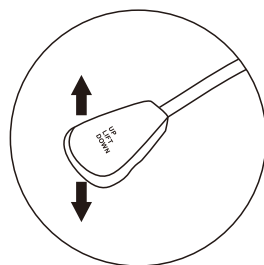

Altezza regolabile:

Premere la maniglia sul lato destro del sedile per regolare l'altezza della sedia.

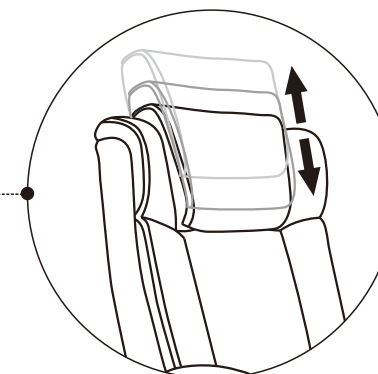
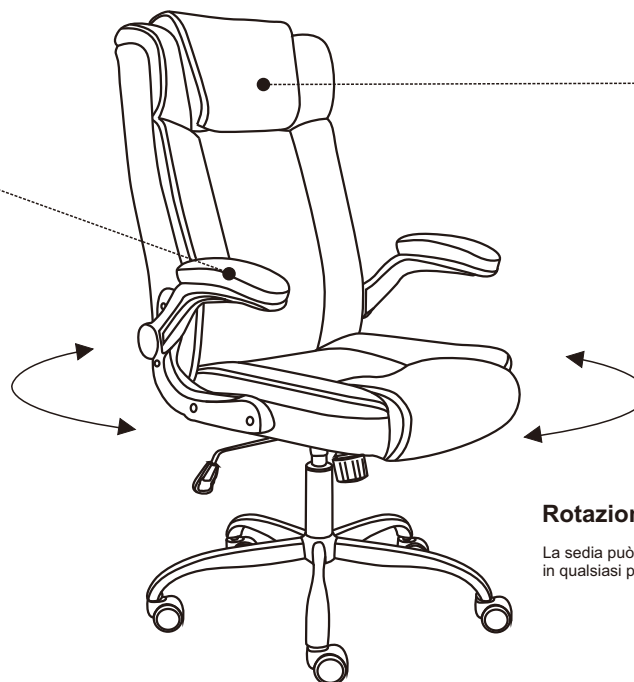

Funzione del poggiatesta:

Il poggiatesta può essere regolato dall'alto verso il basso e fermarsi in qualsiasi posizione.

Rotazione:

La sedia può ruotare e fermarsi in qualsiasi posizione.

⚠ Precauzioni d'uso ⚠

- Evitare la luce diretta del sole, le alte temperature o i luoghi umidi e asciutti.
- Non usarla su pavimenti che scivolano facilmente.
- Si consiglia di riserrare periodicamente i bulloni e viti ogni due mesi.
- Non usarla in caso di viti o bulloni allentati.
- Fare attenzione alle parti mobili delle mani e dei piedi, ecc.
- Per pulire lo sporco consistente, utilizzare un detergente neutro diluito.
- Non sedetevi con forza sul sedile. Se si siede con troppa forza, il carico sopportato sarà maggiore e la sedia potrebbe rompersi.
- Non far sedere più di due persone alla volta.
- Non usare aste di spinta compresi bulloni di regolazione, viti, ecc.
In casa di smarrito, danneggiato o consumato, fino a quando la riparazione di parti corrette
- ※ Se non si osservano i punti di cui sopra, può verificarsi un grave incidente, assicurarsi di osservarli.