

# HAPPINESS HAPPINESS INSTALLATION



## CAUTION

Parts are placed at the bottom of the product.

- If you have any questions with the product, please contact us by:
- **Email: [customerservice@zoy-living.com](mailto:customerservice@zoy-living.com)**  
(we will reply to you within 24 hours)

# Assembly Instructions



## CR0350BF51D

Your recliner comes packaged in **One** box. Carefully remove all of components from the packaging and set aside for assembly.

### CAUTION

DO NOT use any sharp objects to open plastic wrapped components as this may result damage to product or components .

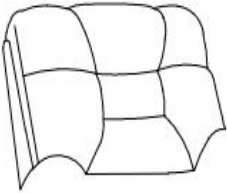
## Package Contents

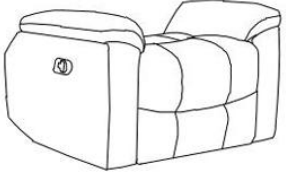
			
A*1 Chair Back	B*1 Left Ear	C*1 Right Ear	D*1 Chair Seat

## Installation Instruction

**Step 1:** Put out all the parts from master carton and check the parts are completed and undamaged according to the above package content list.

**Step 2:** Attach Chair Back(A) to Chair Seat(D) by aligning the metal grooves on backrest to brackets on the main frame as shown. Ensure the Chair Back(A) slides down fully over the brackets on the Chair Seat(D).

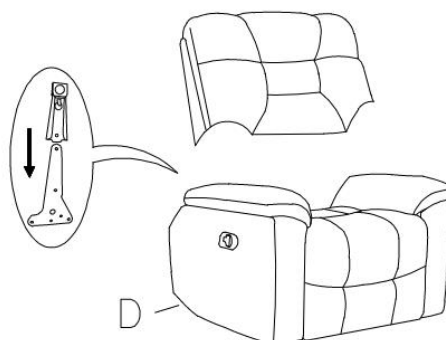

**Step3:** Attach Ears(B&C) to Chair Back(A) by aligning the metal grooves on backrest to brackets on the main frame as shown. Ensure the Ears(B&C) slides down fully over the brackets on the Chair Back(A).

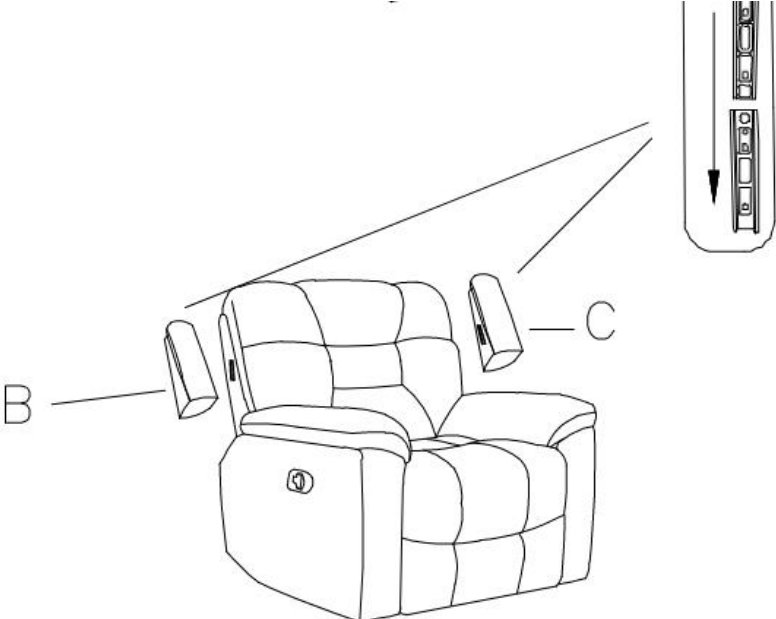

**Assembly Completed**

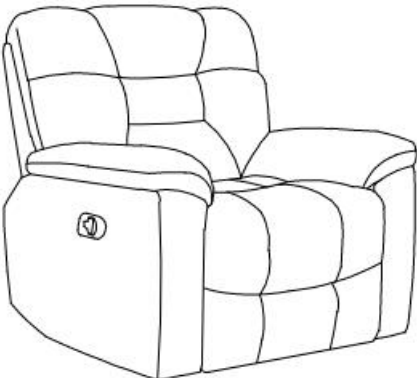

# SIZE DIMENSIONS

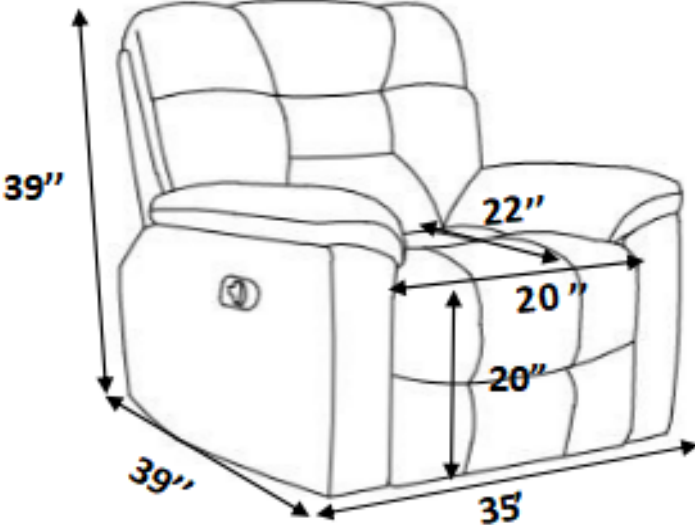

## Warnings

1. Please check if the components of the chair are all included and can be used normally.
2. Assemble all components according to the instruction correctly before you sit in the chair.
3. Please DO NOT sit on the armrests or footrest to eliminate the risk of tipping over.
4. If the chair is damaged or doesn't match the website description, please send clear pictures of the product and label of the carton to our service team for further help.
5. If the recliner doesn't work, you may try the following measures for self-checking firstly:
  - a) check if all the components are firmly connected;
  - b) check if the slides of the sofa are inserted correctly and firmly.

If the recliner still doesn't work, please feed the information back to our customer service in time and we will solve the matter as soon as possible.

6. If you have any questions about our products, please contact us by:

Email: [customerservice@zoy-living.com](mailto:customerservice@zoy-living.com) (we will respond to your inquiry within 24 hours)

