

DINING CHAIR

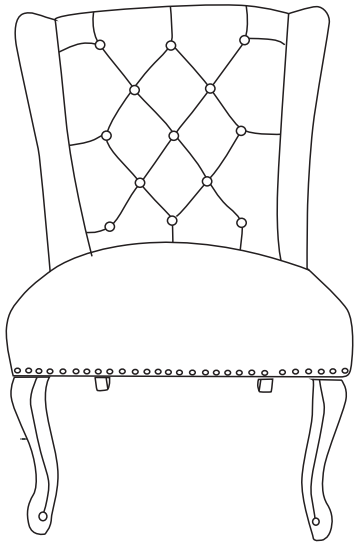

Thank you for purchasing the **DINING CHAIR**

Before you start, here are some helpful advice:

1. We suggest you spend a short time reading through this leaflet and then follow the simple step by step instructions.
2. Owing to the size and weight of the Chair , we recommend that it is assembled by two adults, on a carpeted or padded area, in the room that it is intended for. Approximate assembly time: 30 minutes.
3. Please do not use any tools other than those provided or recommended in these instructions.
4. Please do not throw away any of the packaging or instructions until you have checked all the components and hardware and the furniture is fully assembled.
5. Assemble all components loosely until advised to tighten. Depending on use, it may be necessary to tighten the components from time to time, so please save the tools that have been provided.
6. Please keep all pieces out of reach of children.



Hardware:

A		Bolt M8x65mm	X8
B		Plastic Washer	X8
C		Allen Wrench	X1

Component:

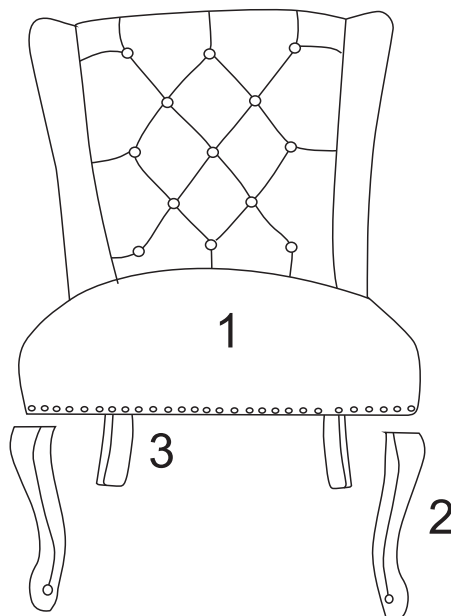

1 Chair Body x1

2 Front Leg x2

3 Back Leg x2

DINING CHAIR

STEP 1:

Please put the **Chair Body (1)** upside down on a carpeted or padded area by two adults.
Open the Velcro on the bottom of **Chair Body (1)** as shown, to make the corners fully visible.
Take out 4 pieces of **Legs (2&3)** and Hardware Package from the inside of **Chair Body(1)**.

Velcro on the bottom of Chair body

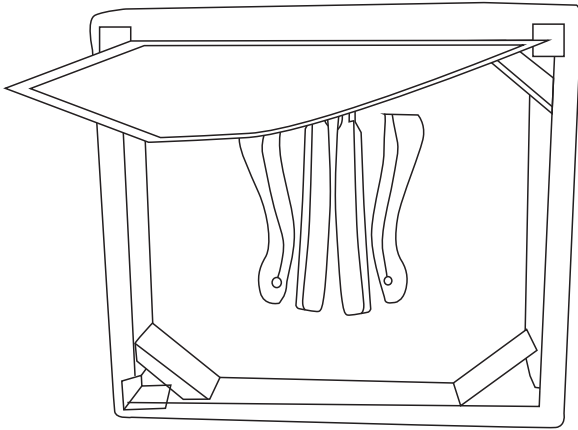

4pcs Chair Leg
+
Hardware Package

STEP 2:

Position one of **Front Legs (2)** at the corresponding wooden corner as shown.
Insert 2 pieces of **Bolts (A)** with 2 pieces of **Plastic Washers (B)** into the pre-drilled holes on the apron of **Chair Body (1)** through the pre-drilled holes on **Front Legs (2)**.
Repeat the same steps for the remaining **Front Leg (2)** and **Back Legs (3)**.
Use **Allen Wrench (C)** to tighten all the **Bolts (A)** clockwise as shown, but do not fully tighten **Bolts (A)** for either leg at this step.

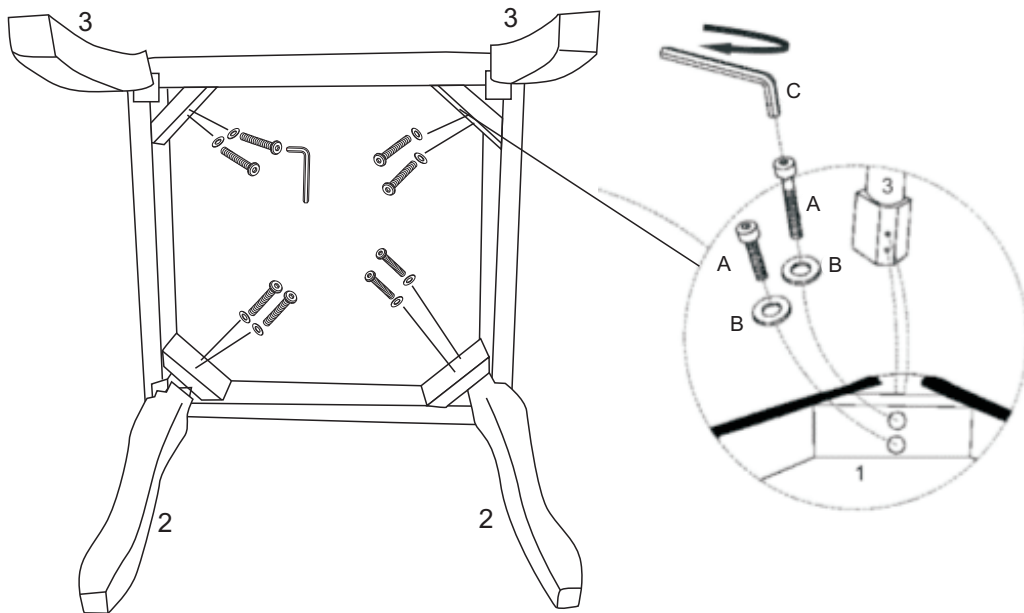

Ax8	Bx8	Cx1

Hardware & Tool required

DINING CHAIR

STEP 3:

Carefully turn over the assembled Chair.

Please put a heavy object or seat one adult on the top of the **Chair Body (1)** to pressure the chair for leveling all legs. Fully tighten the **Bolts (A)** with **Allen Wrench (C)**.

Close the Velcro on bottom of **Chair Body (1)**.

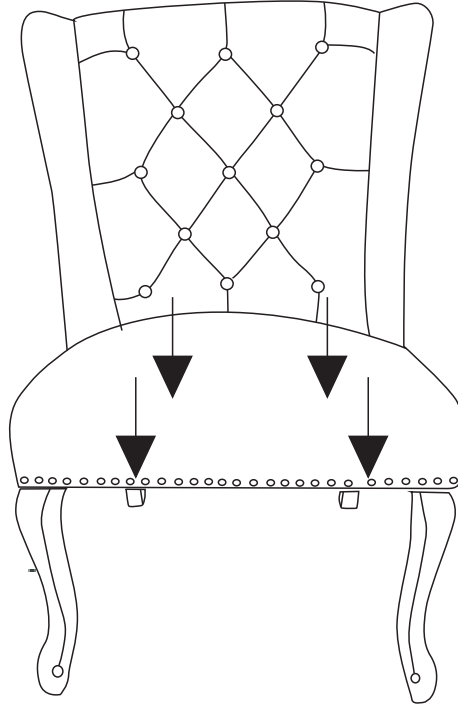

Assembly is completed. Your Chair is ready to be enjoyed now!