

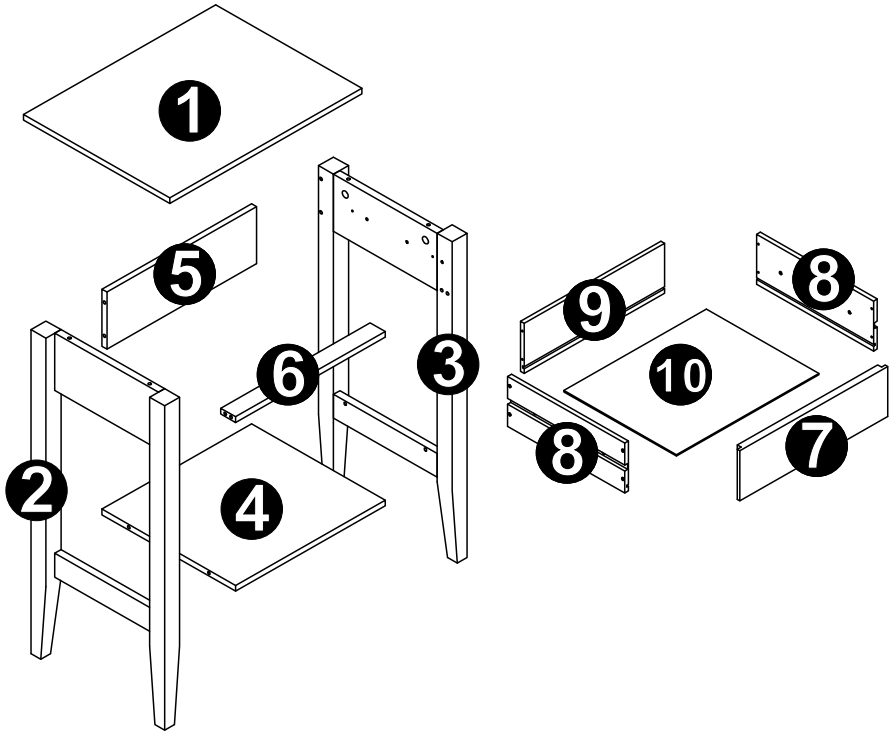

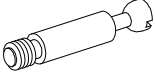



PARTS LIST

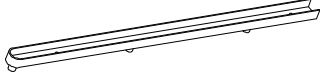

NO	QTY	DESCRIPTION
1	1	Roof
2	1	Left side leg
3	1	Right side leg
4	1	Base board
5	1	Back board
6	1	Front stiffener
7	1	Drawer panel
8	2	Drawer side plate
9	1	Drawer back board
10	1	Drawer baseboard

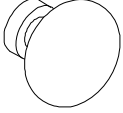
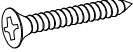
NO	PARTS	QTY	DESCRIPTION
A		14PCS	Eccentric rod
B		14PCS	Eccentric gear
C		2PCS	Wood plug
D		2PCS	Plastic slide way
E		4PCS	Self-tapping screw
F		1PC	Handle
G		8PCS	Self-tapping screw
H		1PC	Handle Screw
I		2PCS	Plastic damper

**TOOLS NEEDED FOR ASSEMBLY: FLAT & PHILLIPS SCREWDRIVER (NOT INCLUDED)
THE USE OF POWER SCREWDRIVER IS NOT RECOMMENDED**

STEP1

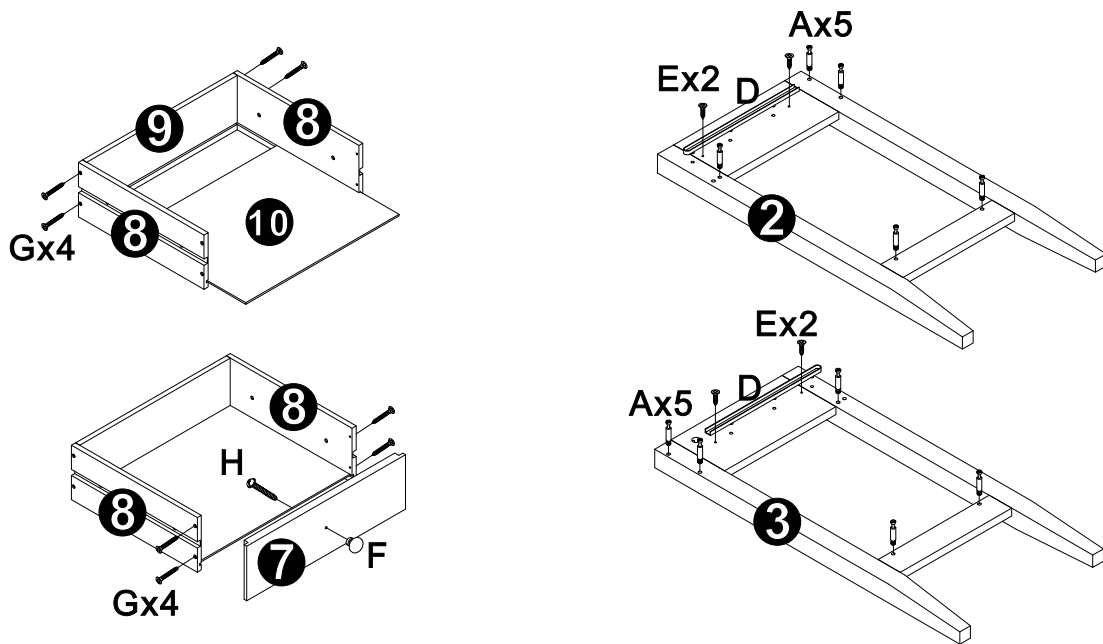

Step1

(1) Use screw G to lock plate No. 8 and No.9 together, put the plate No. 10 along the slot. And use the screw G locks number 7 and 8 plates together, then lock handle F to plate No.7 using handle screw H

(2) Use screw E locks the plastic slide way D on the plate No.2 and No.3, and locks the eccentric rod A on the plate No. 2 and No.3

STEP2

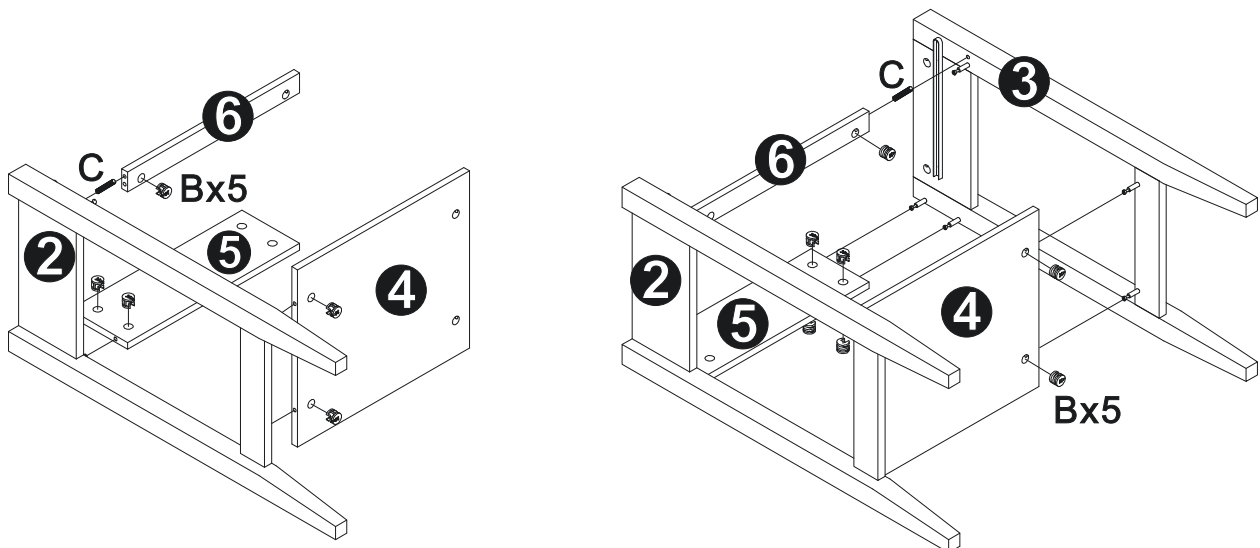

Step2

(1) Use the eccentric rod B locks plate No.2, No.4 and No.5 together, and use wood plug C connects plate No.2 and No.6 together, locking with eccentric rod B

(2) Use the eccentric rod B locks plate No.3, No.4 and No.5 together, and uses wood plug C connect plate No. 3 and No.6 together, locking with eccentric rod B

STEP3

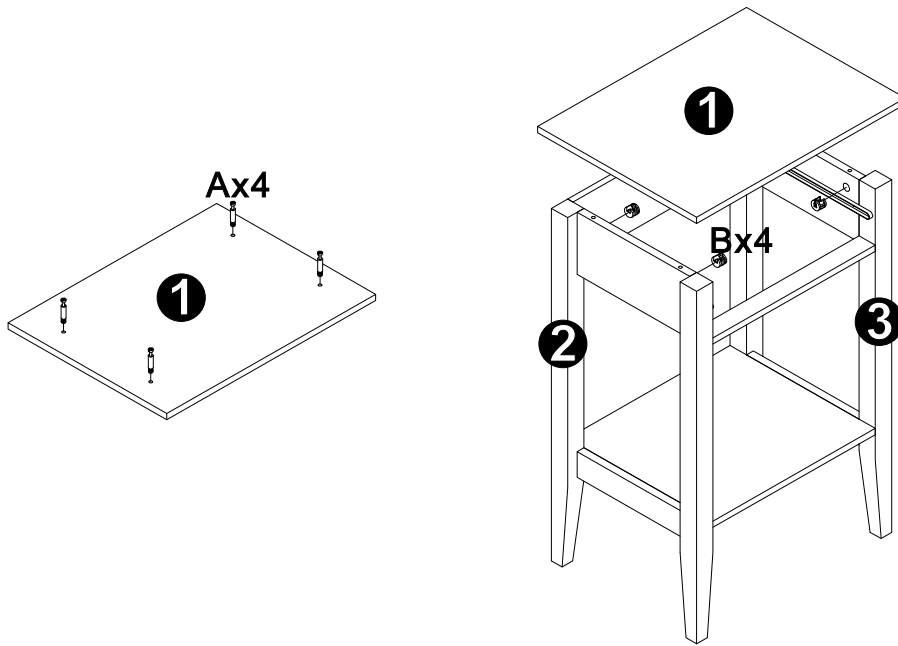

Step3

- (1) Lock eccentric rod A on the plate No.1.
- (2) Use the eccentric rod B locks No.1 plate with the assembled components together.

STEP4

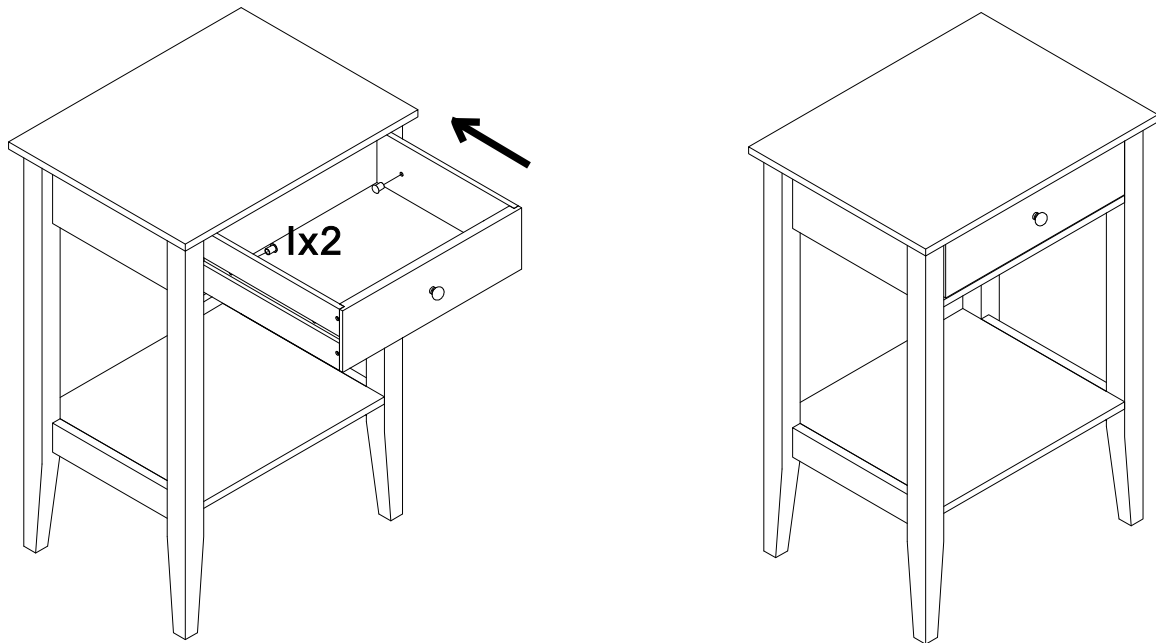

Step4

- (1) Put the assembled drawer along into orbit, and then put the plastic damper I in the hole.