



SKU:KHD-CY-TB05-UP

## Assembly Guide

### Tip!

Do check for all the components and screws listed in this guide before putting things together. If any part is missing, contact us at support@vecelo.com (US / CA ) or support-euteam@vecelo.com ( EU ) for the missing part.

### Return Policy

Your satisfaction is our top priority. If our product fails to satisfy you, please let us know how we can make things right for you. Our trained customer care team can handle most concerns and assist you with any questions you may have. Simply shoot them a message at support@vecelo.com(US/CA) or support-euteam@vecelo.com(EU) with your order number and question. To be eligible for a full-refund return, the item must be in pristine condition, in the original packaging, with all of the shipped components intact and not yet assembled, and with the item's unique proof of purchase.

### Trouble shooting:

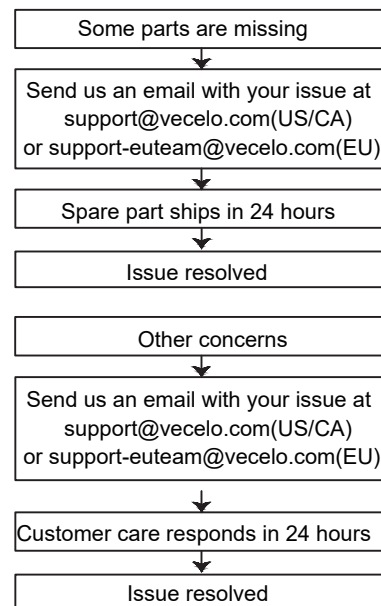

We run our own manufacturer, so rest assured about the quality consistency.

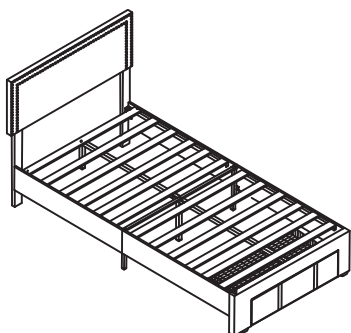

Item Description: Bed Frame

Model NO: CY-NO.1



SKU:KHD-CY-TB05-UP

## Montageanleitung

### Tipp!

ÜBERPRÜFEN Sie alle in dieser Anleitung aufgeführten Komponenten und Schrauben, bevor Sie die Bauteile zusammenbauen. Sollte ein Bauteil fehlen, kontaktieren Sie uns unter support-euteam@vecelo.com um Ersatz zu erhalten.

### Rückgabegerichtlinie

Ihre Zufriedenheit ist unsere oberste Priorität. Wenn Sie mit unserem Produkt nicht zufrieden sind, lassen Sie uns bitte wissen, wie wir die Angelegenheit für Sie in Ordnung bringen können. Unser geschultes Kundenbetreuer kann die meisten Anliegen lösen und unter Sie bei allen Ihren Fragen. Senden Sie uns einfach eine Nachricht an support-euteam@vecelo.com mit Ihrer Bestellnummer und Ihrer Frage. Um eine volle Rückerstattung zu erhalten, muss der Artikel in einwandfreiem Zustand sein und sich in der Originalverpackung mit allen gelieferten und noch nicht zusammengebaute Komponenten befinden. Zudem wird der eindeutige Kaufnachweis des Artikels.

### Problemlösung:

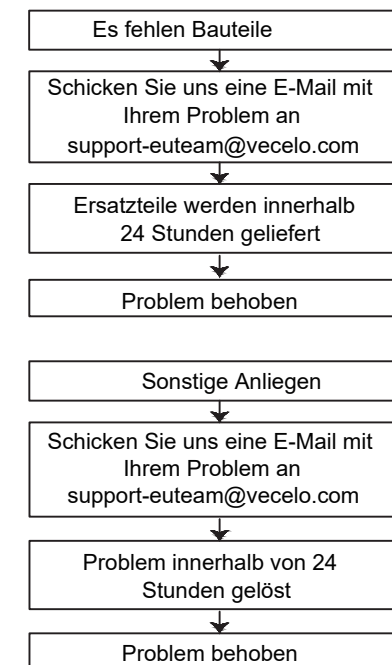

Wir stellen unsere Artikel selbst her, sodass Sie sich auf gleichbleibende Qualität verlassen können.

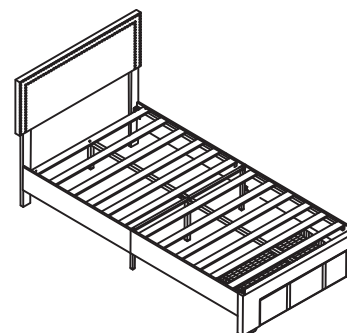

Item Description: Bettrahmen

Model NO: CY-NO.1

SKU:KHD-CY-TB05-UP



## Guide de montage

### Attention !

VÉRIFIEZ la présence de l'ensemble des éléments et vis énumérés dans ce guide avant de procéder au montage. Si une pièce venait à manquer, envoyez-nous un e-mail à support-euteam@vecelo.com pour nous le signaler.

### Politique de retour

Votre satisfaction est notre priorité absolue. Si notre produit ne vous donne pas entière satisfaction, n'hésitez pas à nous faire savoir ce que nous pouvons faire pour améliorer la situation. Notre équipe d'assistance à la clientèle qualifiée est en mesure de résoudre la plupart de vos problèmes et de répondre à toutes vos questions. Il vous suffit de leur envoyer un message à l'adresse support-euteam@vecelo.com en indiquant votre numéro de commande et votre question. Pour pouvoir bénéficier d'un remboursement intégral, l'article doit être en parfait état, dans son emballage d'origine, avec tous les composants expédiés intacts et non encore assemblés, et avec la preuve d'achat unique de l'article.

### Dépannage :

Certains pièces manquent

Envoyez-nous un e-mail en nous expliquant votre problème à support-euteam@vecelo.com

Pièces de rechange envoyées dans les 24 heures

Problème résolu

Vous avez d'autres problèmes ?

Envoyez-nous un e-mail en nous expliquant votre problème à support-euteam@vecelo.com

Problème résolu dans les 24 heures

Problème résolu

Nous assurons notre propre fabrication, donc soyez assuré de bénéficier d'une qualité constante.

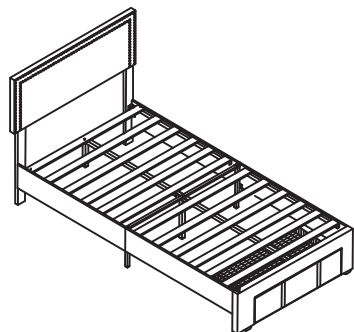

Item Description: Cadre de lit

Model NO: CY-NO.1

SKU:KHD-CY-TB05-UP



## Guida all'assemblaggio

### Suggerimento!

Controllare tutti i componenti e le viti elencati in questa guida prima di assemblare il tutto. Se manca qualche parte, contattaci a support-euteam@vecelo.com per le parti mancanti.

### Politica di reso

La vostra soddisfazione è la nostra massima priorità. Se il nostro prodotto non ti soddisfa, faccelo sapere e ti aiuteremo a risolvere il problema. Il nostro team di assistenza clienti qualificato può gestire la maggior parte delle preoccupazioni e assisterti per qualsiasi domanda tu possa avere. Inviaci semplicemente un messaggio a support-euteam@vecelo.com con il tuo numero d'ordine e la tua richiesta. Per essere idoneo a un reso con rimborso completo, l'articolo deve essere in ottime condizioni, nella confezione originale, con tutti i componenti intatti e non ancora assemblati, e con una prova d'acquisto valida.

### Risoluzione dei problemi:

Mancano alcune parti

Inviaci un'e-mail con il tuo problema a support-euteam@vecelo.com

Il pezzo di ricambio viene spedito in 24 ore

Problema risolto

Altre preoccupazioni

Inviaci un'e-mail con il tuo problema a support-euteam@vecelo.com

L'assistenza clienti risponde in 24 ore

Problema risolto

Gestiamo il nostro produttore, quindi riposati assicurato circa la consistenza di qualità.

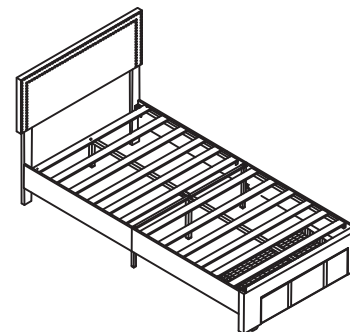

Descrizione dell'articolo: Telaio del letto

Modello NO: CY-NO.1



## Guía de montaje

### Consejo !

Verifique todos los componentes y tornillos. Enumerados en esta guía antes de poner las cosas juntos. Si falta alguna pieza, contáctanos al support-euteam@vecelo.com por los desaparecidos parte.

### Política de devoluciones

Su satisfacción es nuestra máxima prioridad. Si nuestro el producto no le satisface, háganoslo saber. CÓMO podemos hacer las cosas bien para usted. Nuestro equipo de atención al cliente capacitado puede manejar la mayoría inquietudes y ayudarle con cualquier pregunta es posible que tengas. Simplemente envíales un mensaje en support-euteam@vecelo.com con su número de pedido y pregunta. Ser elegible para una devolución con reembolso completo, el artículo debe estar en impecable estado, en el embalaje original, con todos los componentes enviados intactos y aún no ensamblado y con la característica única del artículo. Comprobante de compra.

SKU:KHD-CY-TB05-UP

Solución de problemas:

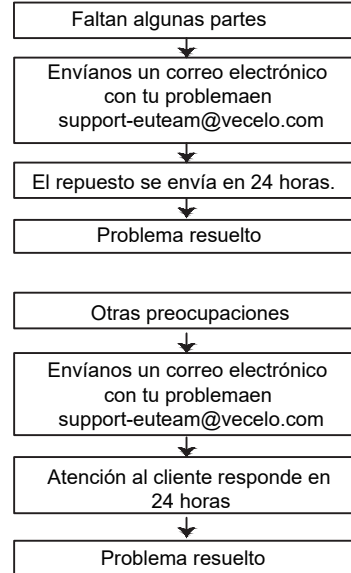

Dirigimos nuestro propio fabricante, así que descansa. Asegurado sobre la consistencia de la calidad

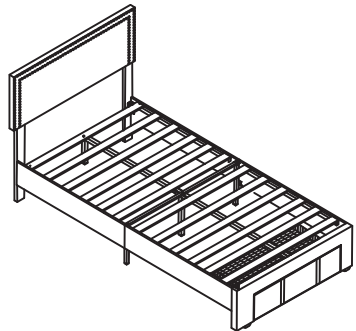

Descripción del artículo: Marco de la cama

Modelo NO: CY-NO.1

## CAUTION!



## ACHTUNG!



## ATTENTION !



## CAUTELA!







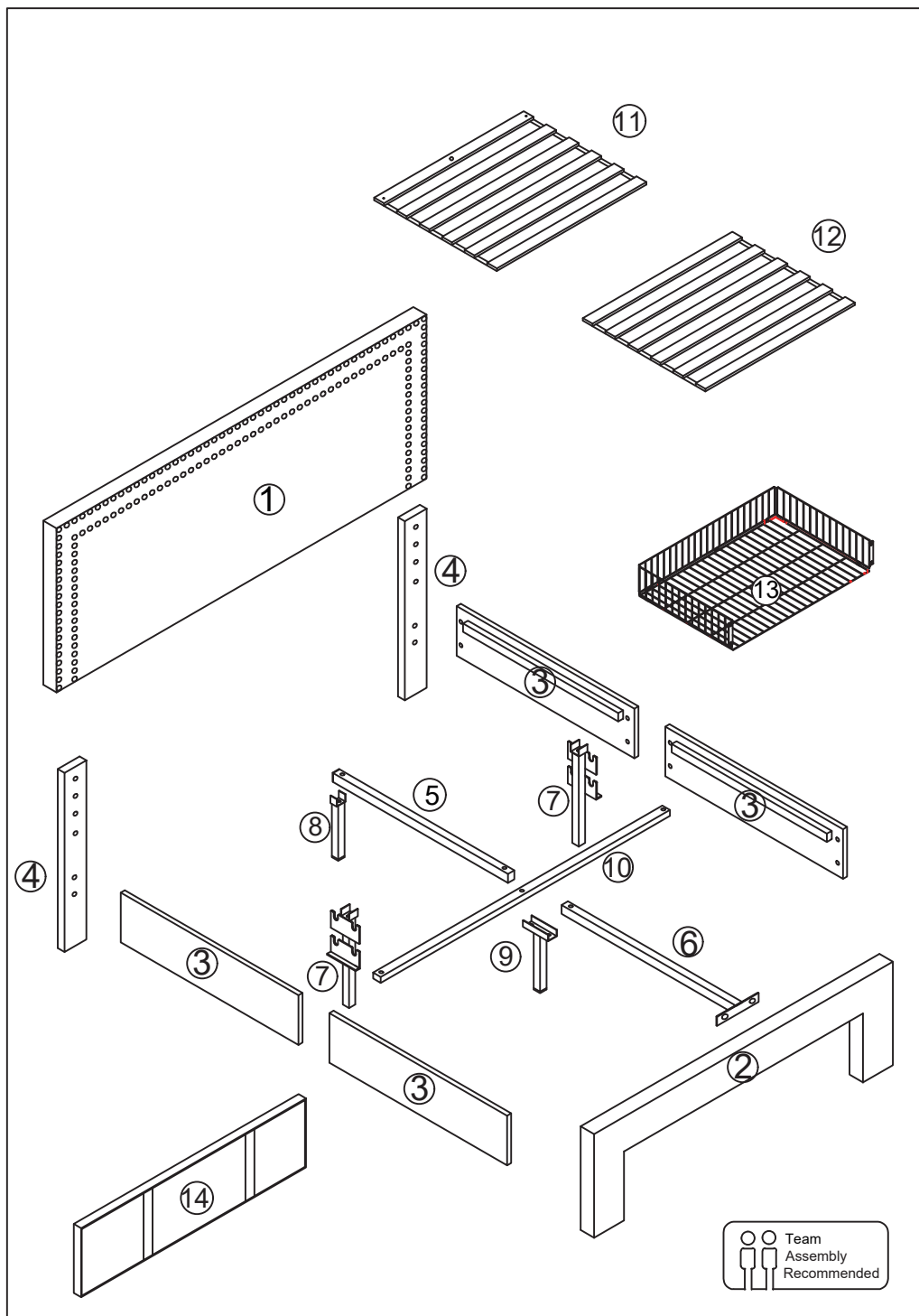







## PRECAUCIÓN !

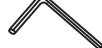

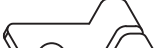

Components/ Bauteile / Composants / Componenti / Componentes					
①		1pcs	②		1pcs
③		4pcs	④		2pcs
⑤		1pcs	⑥		1pcs
⑦		2pcs	⑧		1pcs
⑨		1pcs	⑩		1pcs
⑪		1pcs	⑫		1pcs
⑬		1PCS	⑭		1pcs

Screws & Tools / Schrauben und Werkzeuge / Vis et outils / Viti e utensili / Tornillos y Herramientas					
(A)	 Bolt M6 x 15	5+1pcs	(B)	 Bolt M8 x 16	16+1pcs
(C)	 Bolt M8 x 25	14+1pcs	(D)	 Bolt M8 x 45	7+1pcs
(E)	 Spacer	4pcs	(F)	 SCREW M4*25	2pcs
(G)	 Allen Key M5	1pcs	(H)	 Allen Key M4	1pcs

Screws & Tools / Schrauben und Werkzeuge / Vis et outils / Viti e utensili / Tornillos y Herramientas					
(I)	 Angle iron	2pcs	(J)	 Angle iron	2pcs
(K)	 Hook	1pcs	(L)	 Plastic Buckles	2pcs
(M)	 Wheel	5pcs	(O)	 L-shaped bracket	2pcs

### Step 1



D\*4



E\*4



G\*1

- Each pair of holes corresponds to a mattress thickness as shown below.
- ★ Chaque paire de trous correspond à une épaisseur de matelas, comme indiqué ci-dessous.
- ▲ Jedes Paar Löcher entspricht einer Matratzenstärke, wie unten gezeigt.
- Ogni coppia di fori corrisponde ad uno spessore del materasso come mostrato di seguito.
- ✿ Cada par de agujeros corresponde al grosor del colchón, como se muestra a continuación.

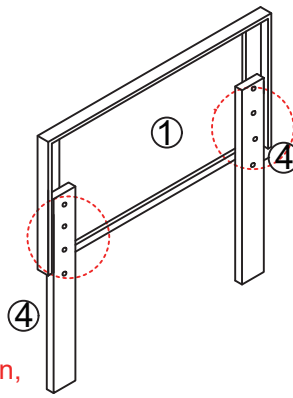

- Use these holes to fit a 12 inch thick mattress (45.6 inch tall overall)
- ★ Utilisez ces trous pour s'adapter à un matelas de 12 Centimètres d'épaisseur (45.6 Centimètres de hauteur totale)
- ▲ Jedes Paar Löcher entspricht einer Matratzendicke. Um eine 12-Zentimeter-Matratze anzupassen (Insgesamt 45.6 Zentimeter)
- Utilizzare questi fori per adattarsi a un materasso spesso 12 pollici (alto complessivamente 45.6 pollici)
- ✿ Utilice estos agujeros para adaptarse a un colchón de 12 pulgadas de grosor (45.6 pulgadas de alto en total)

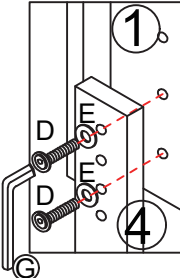

- Use these holes to fit a 10 inch thick mattress (43.6 inch tall overall)
- ★ Utilisez ces trous pour s'adapter à un matelas de 10 Centimètres d'épaisseur (43.6 Centimètres de hauteur totale)
- ▲ Jedes Paar Löcher entspricht einer Matratzendicke. Um eine 10-Zentimeter-Matratze anzupassen (Insgesamt 43.6 Zentimeter)
- Utilizzare questi fori per adattarsi a un materasso spesso 10 pollici (alto complessivamente 43.6 pollici)
- ✿ Utilice estos agujeros para adaptarse a un colchón de 10 pulgadas de grosor (43.6 pulgadas de alto en total)

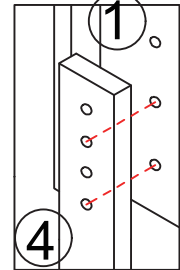

## Step 1

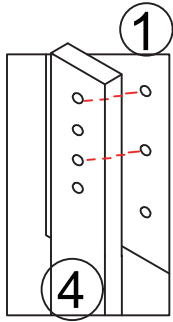

- Use these holes to fit a 8 inch thick mattress (41.6inch tall overall)
- ★ Utilisez ces trous pour s'adapter à un matelas de 8 Centimètres d'épaisseur (41.6 Centimètres de hauteur totale)
- ▲ Jedes Paar Löcher entspricht einer Matratzendicke. Um eine 8-Zentimeter-Matratze anzupassen (Insgesamt 41.6 Zentimeter)
- Utilizzare questi fori per adattarsi a un materasso spesso 8 pollici (alto complessivamente 41.6 pollici)
- ☀ Utilice estos agujeros para adaptarse a un colchón de 8 pulgadas de grosor (41.6 pulgadas de alto en total)

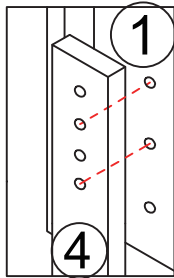

- Use these holes to fit a 6 inch thick mattress (39.6 inch tall overall)
- ★ Utilisez ces trous pour s'adapter à un matelas de 6 Centimètres d'épaisseur (39.6 Centimètres de hauteur totale)
- ▲ Jedes Paar Löcher entspricht einer Matratzendicke. Um eine 6-Zentimeter-Matratze anzupassen (Insgesamt 39.6 Zentimeter)
- Utilizzare questi fori per adattarsi a un materasso spesso 6 pollici (alto complessivamente 39.6 pollici)
- ☀ Utilice estos agujeros para adaptarse a un colchón de 6 pulgadas de grosor (39.6 pulgadas de alto en total)

## Step 2

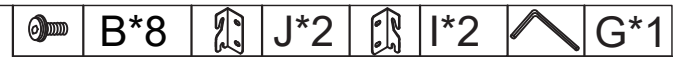

**Tips:**  
**Must Keep the Brackets**  
**Lay Toward the Ground**

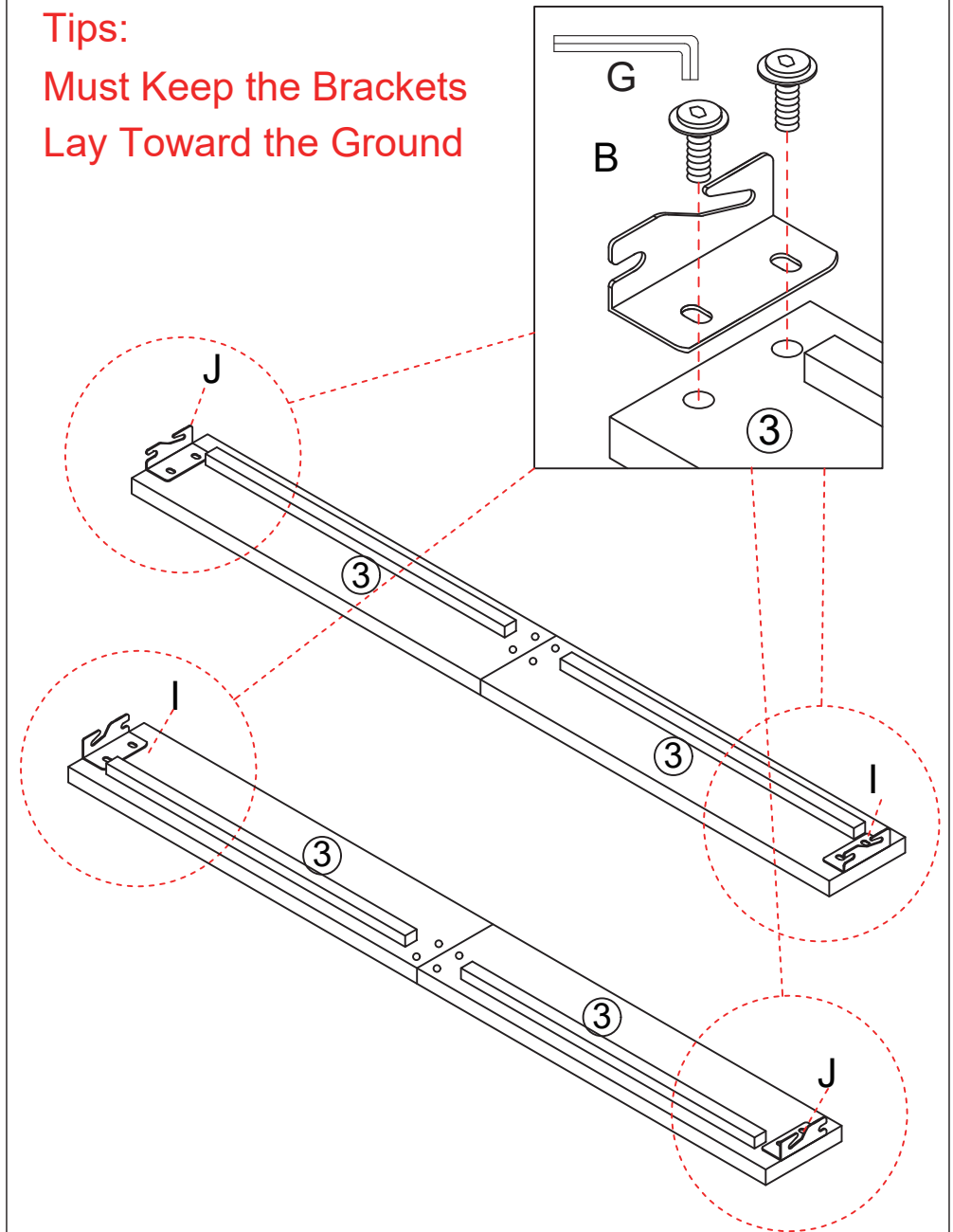

Step 3

B\*8 G\*1

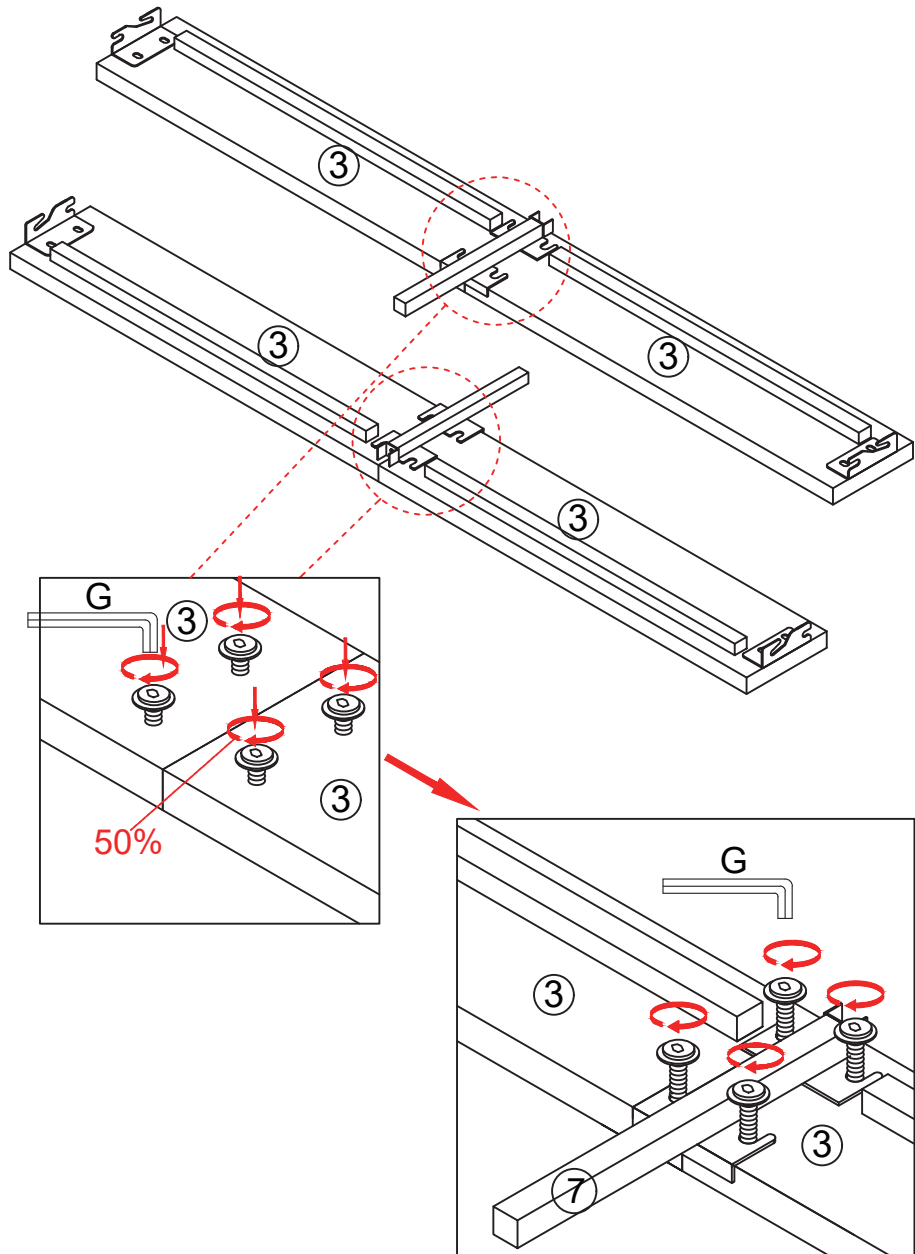

Step 4

C\*8 G\*1

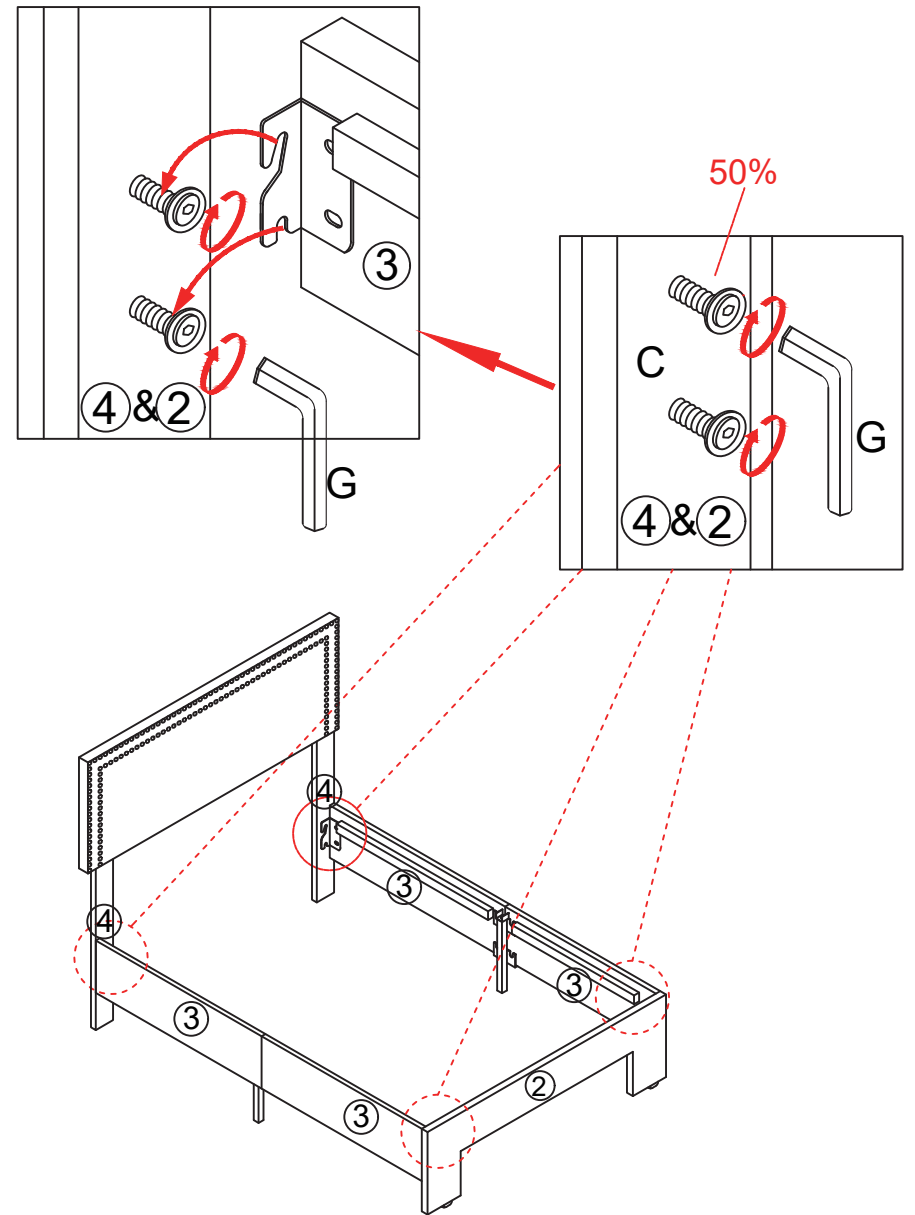

Step 5

C\*2 G\*1

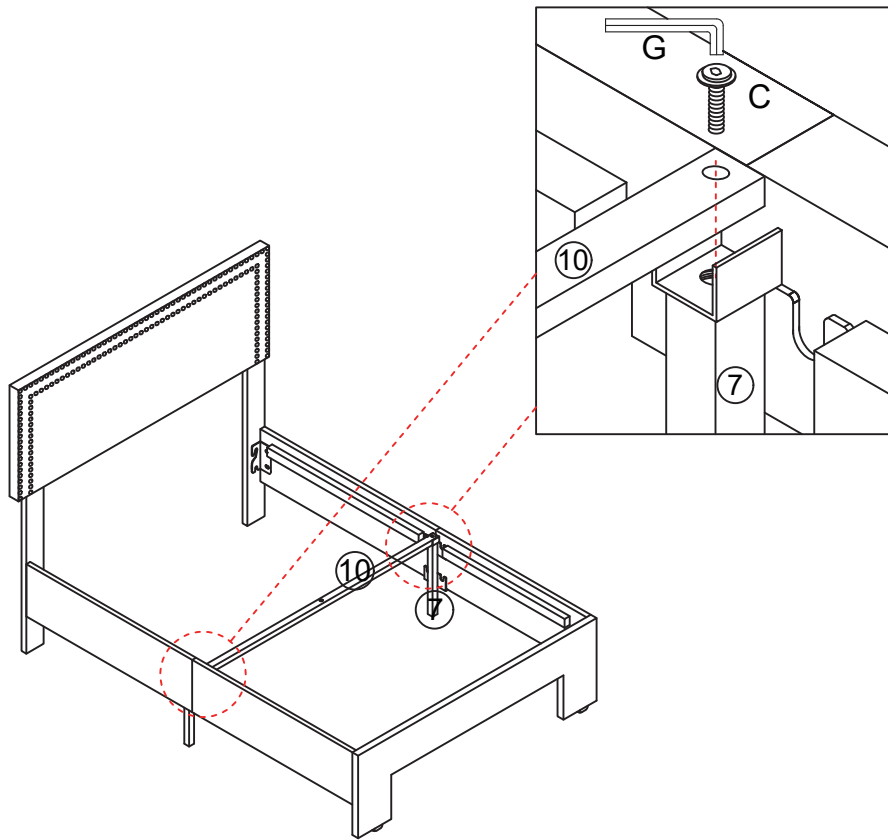

Step 6

C\*2 D\*2 G\*1

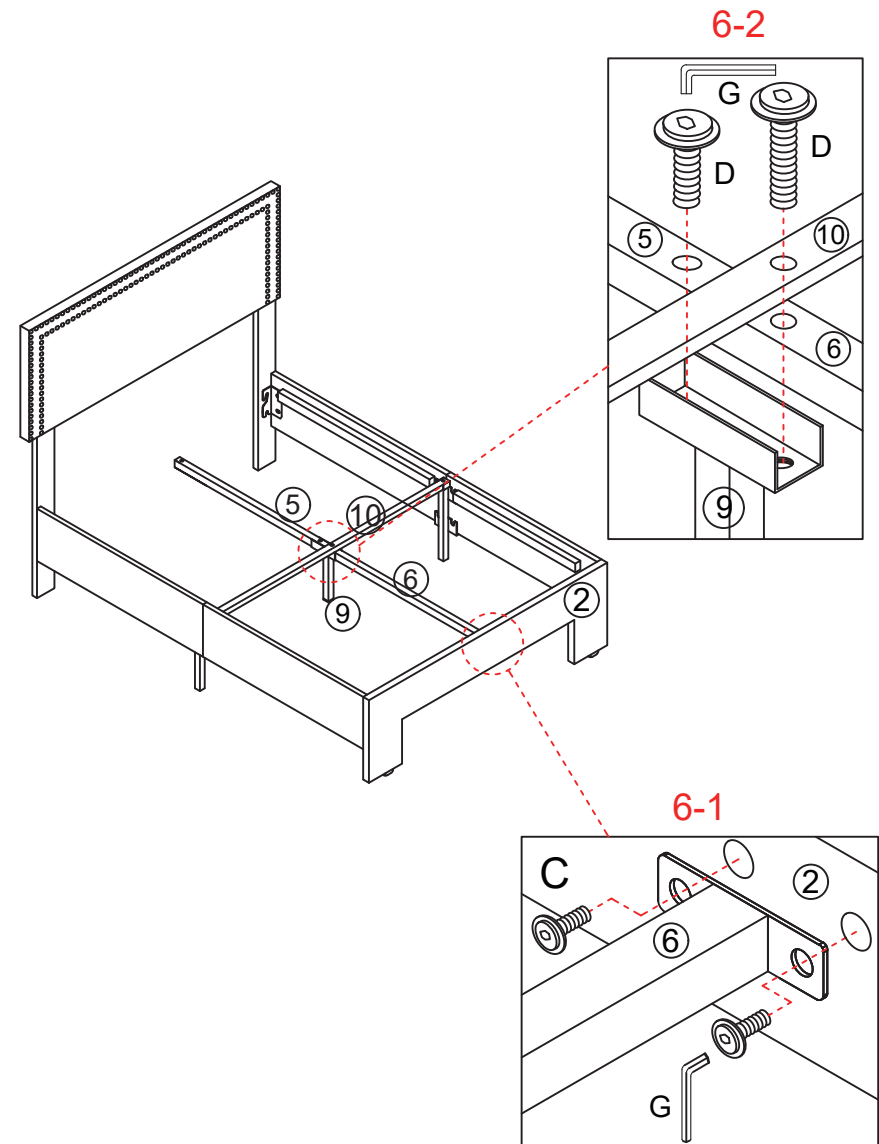

Tighten the original screw

# Step 7

C\*2 O\*2 G\*1

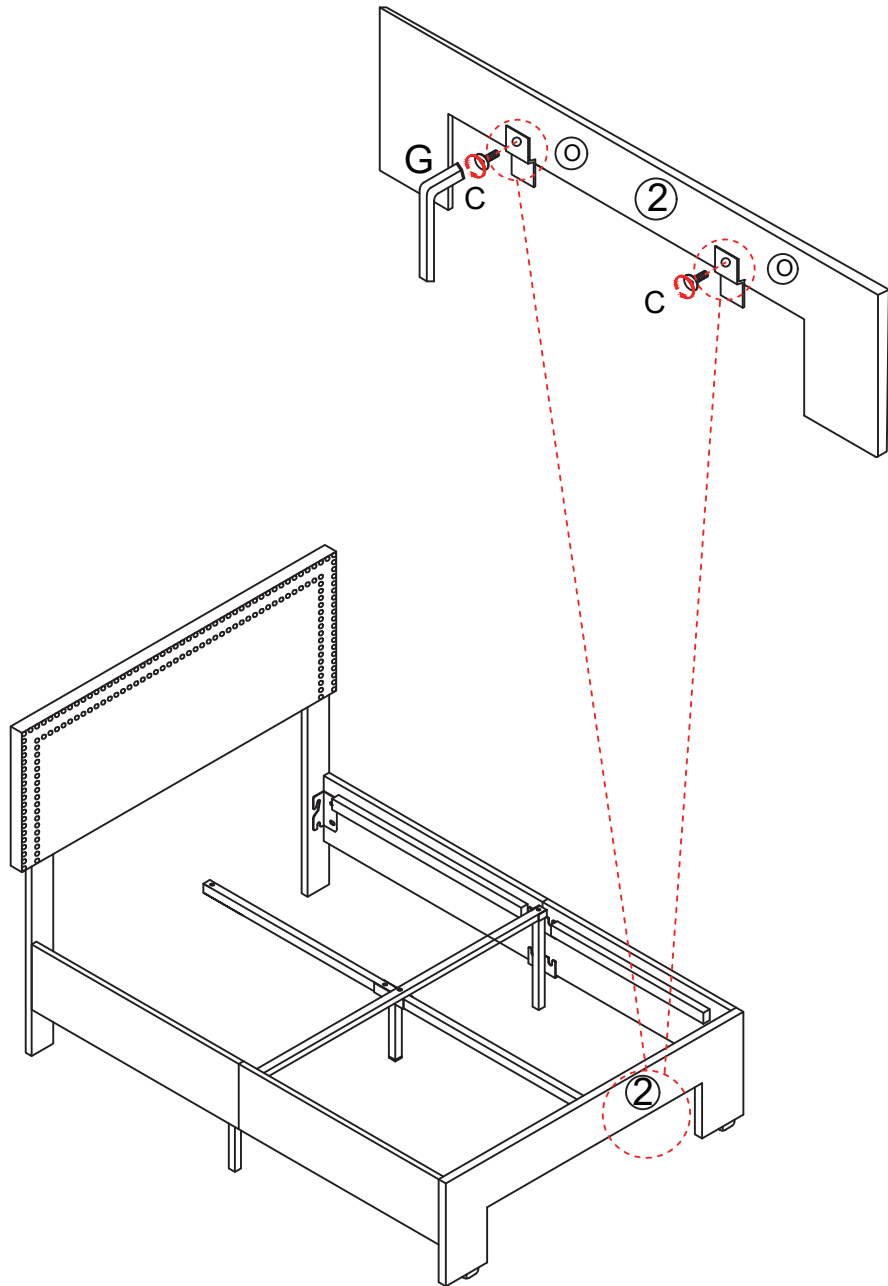

# Step 8

 please make sure the hole position.

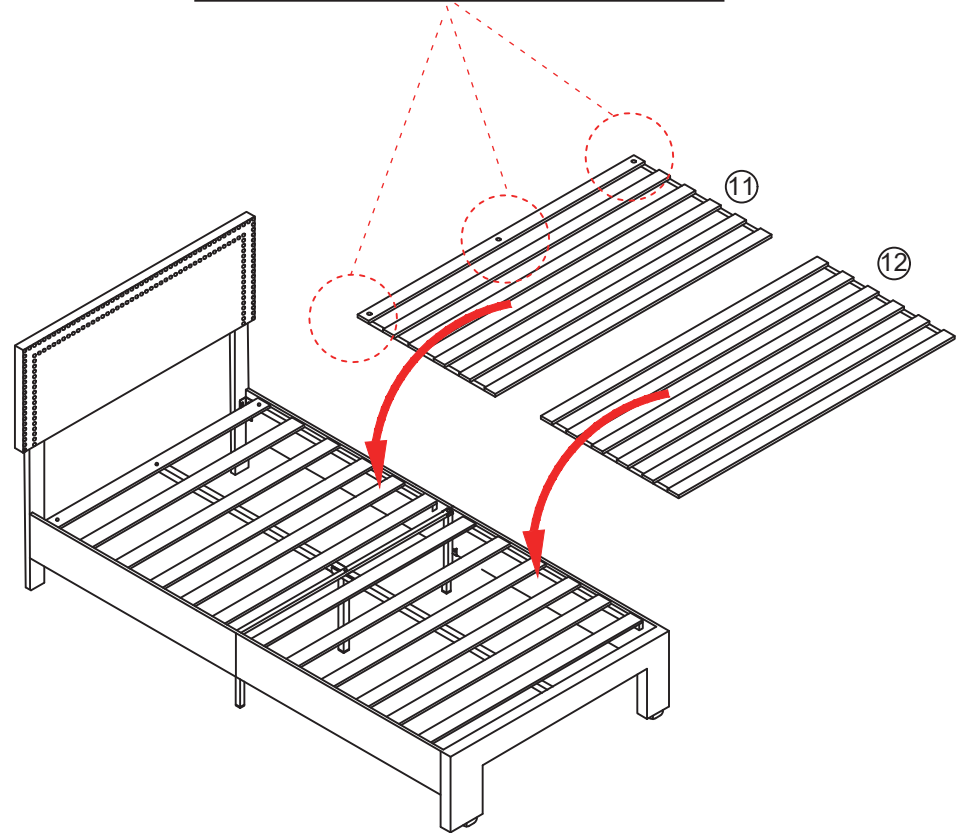

Step 9

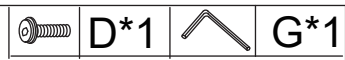

 please tighten the screw.

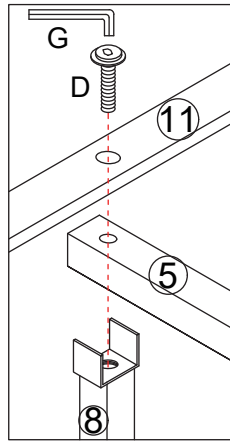
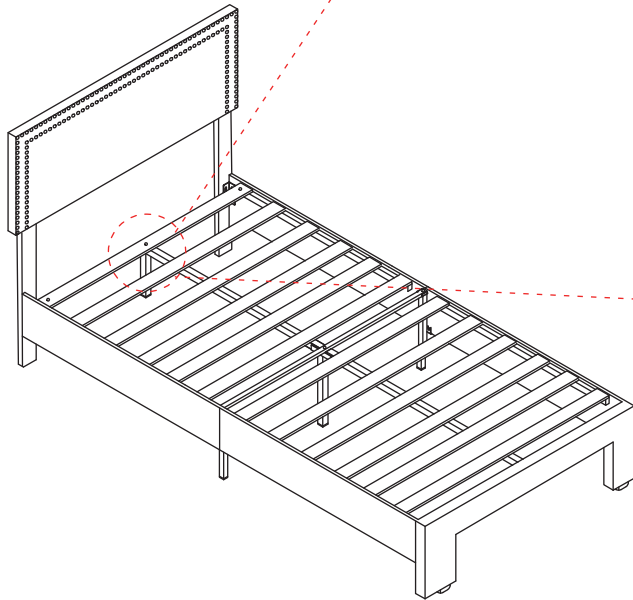

Step10

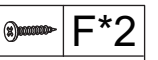

 please tighten the screw.

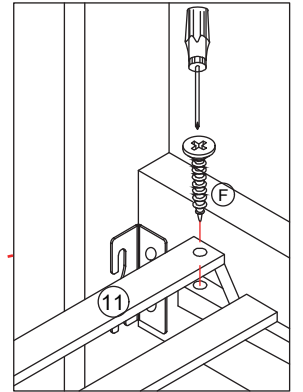
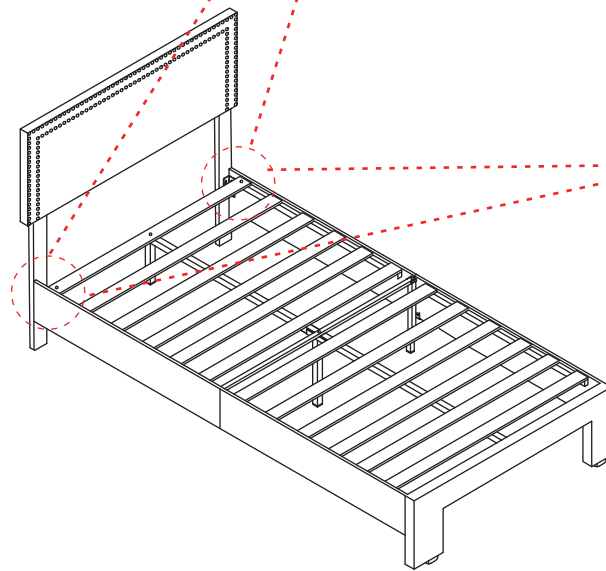

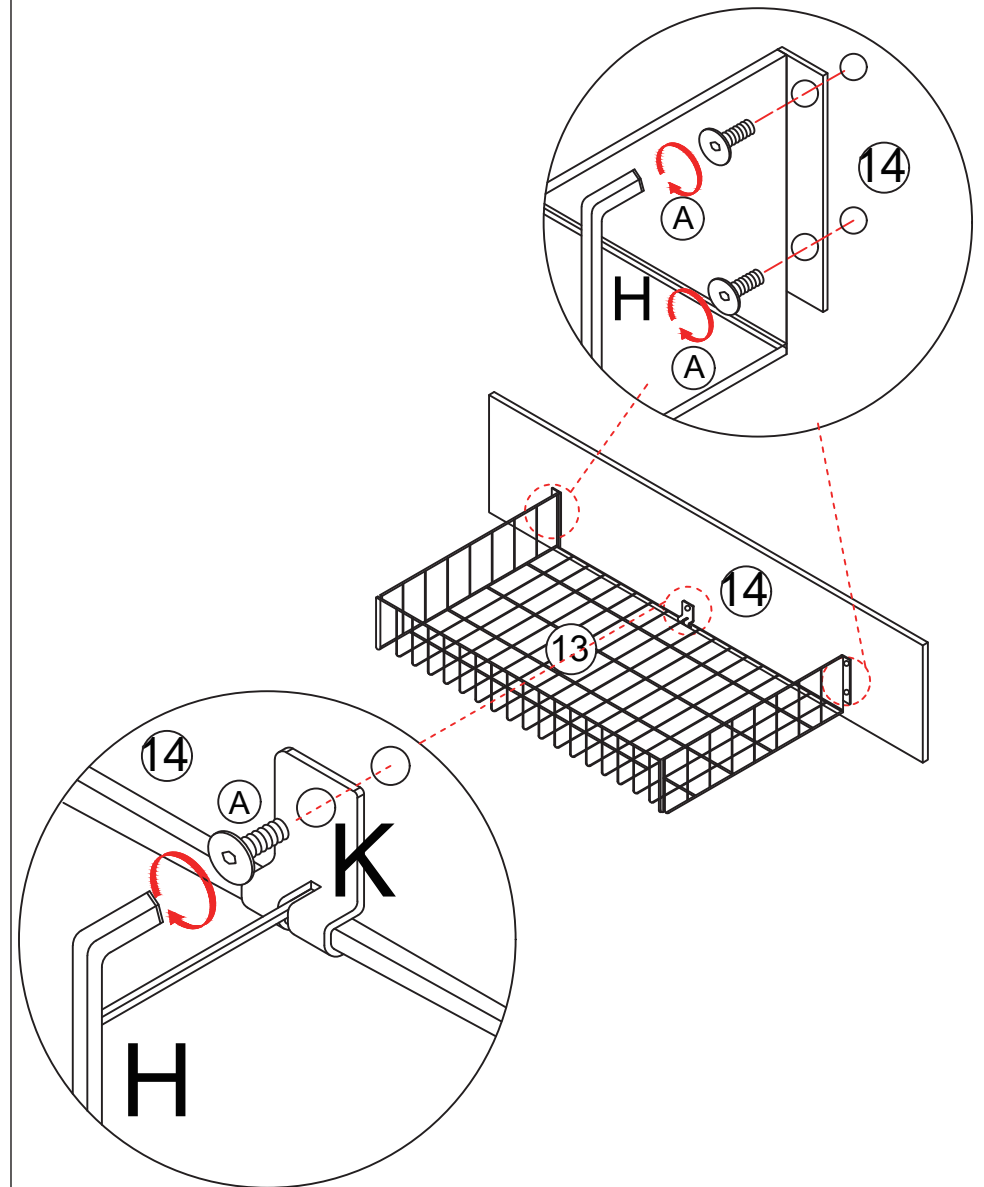
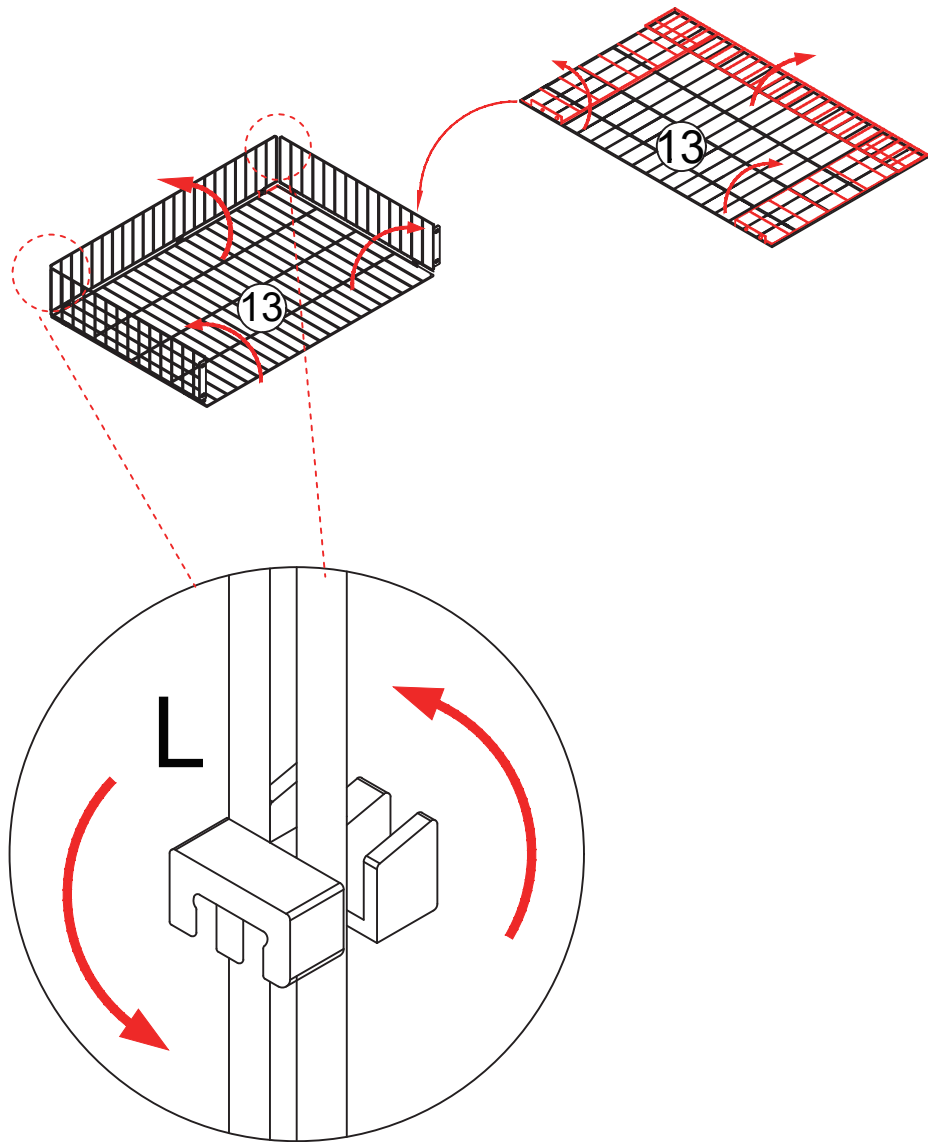

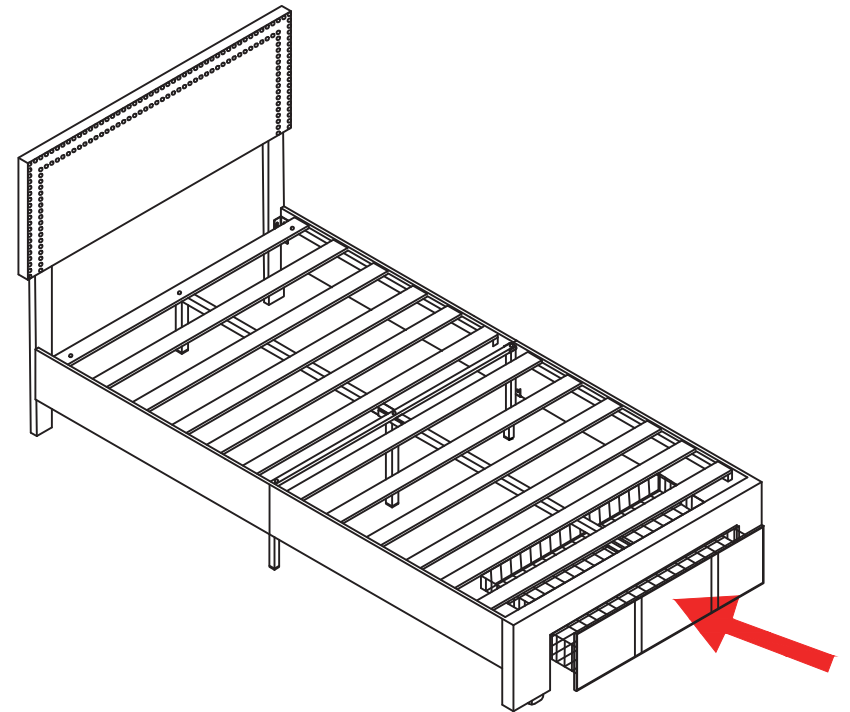
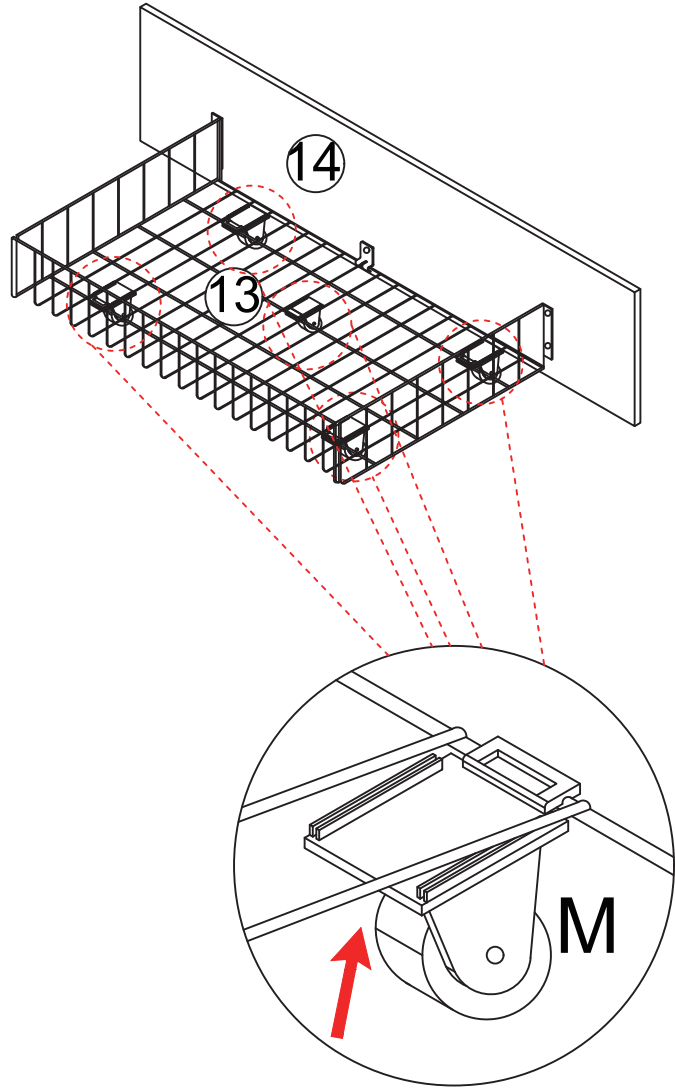

## Step15

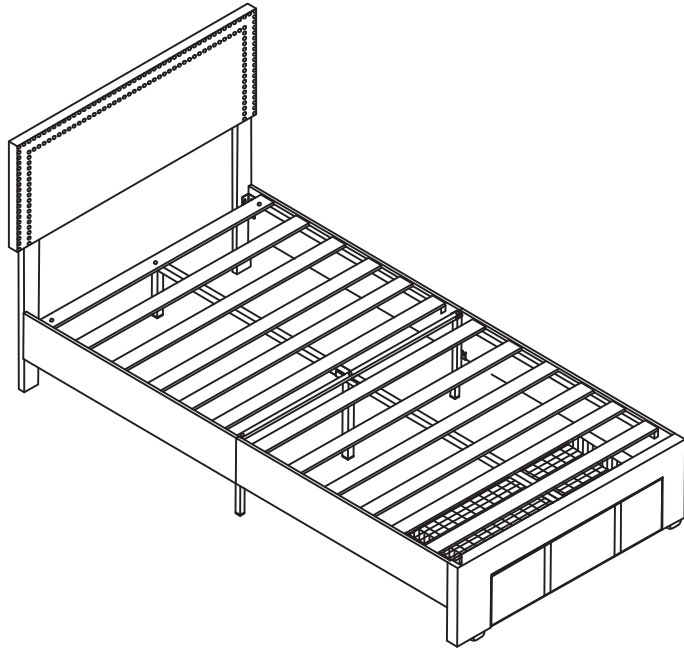

- Note: Now remember to double check all screws are properly fastened.
- ★ Hinweis: Vergessen Sie jetzt nicht, zu überprüfen, ob alle Schrauben richtig angezogen sind.
- ▲ Remarque : N'oubliez pas de vérifier que toutes les vis sont bien serrées.
- Nota: Ora ricordati di ricontrollare che tutte le viti siano correttamente fissate.
- ✿ Nota: Ahora recuerde volver a verificar que todos los tornillos estén correctamente apretados.

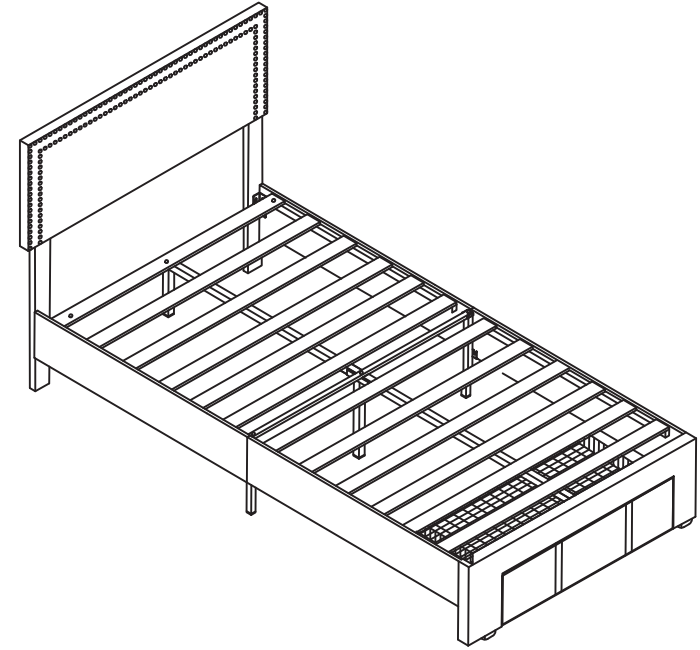

CONTACT US  
KONTAKTIEREN SIE UNS  
NOUS CONTACTER  
CONTATTACI  
CONTÁCTENOS



Tel: +1(570)530-2113  
E-mail: [support@vecelo.com](mailto:support@vecelo.com) ( US/CA )  
E-mail: [support-euteam@vecelo.com](mailto:support-euteam@vecelo.com) ( EU/FR/DE/ES/IT )  
Website: [www.vecelo.com](http://www.vecelo.com)