

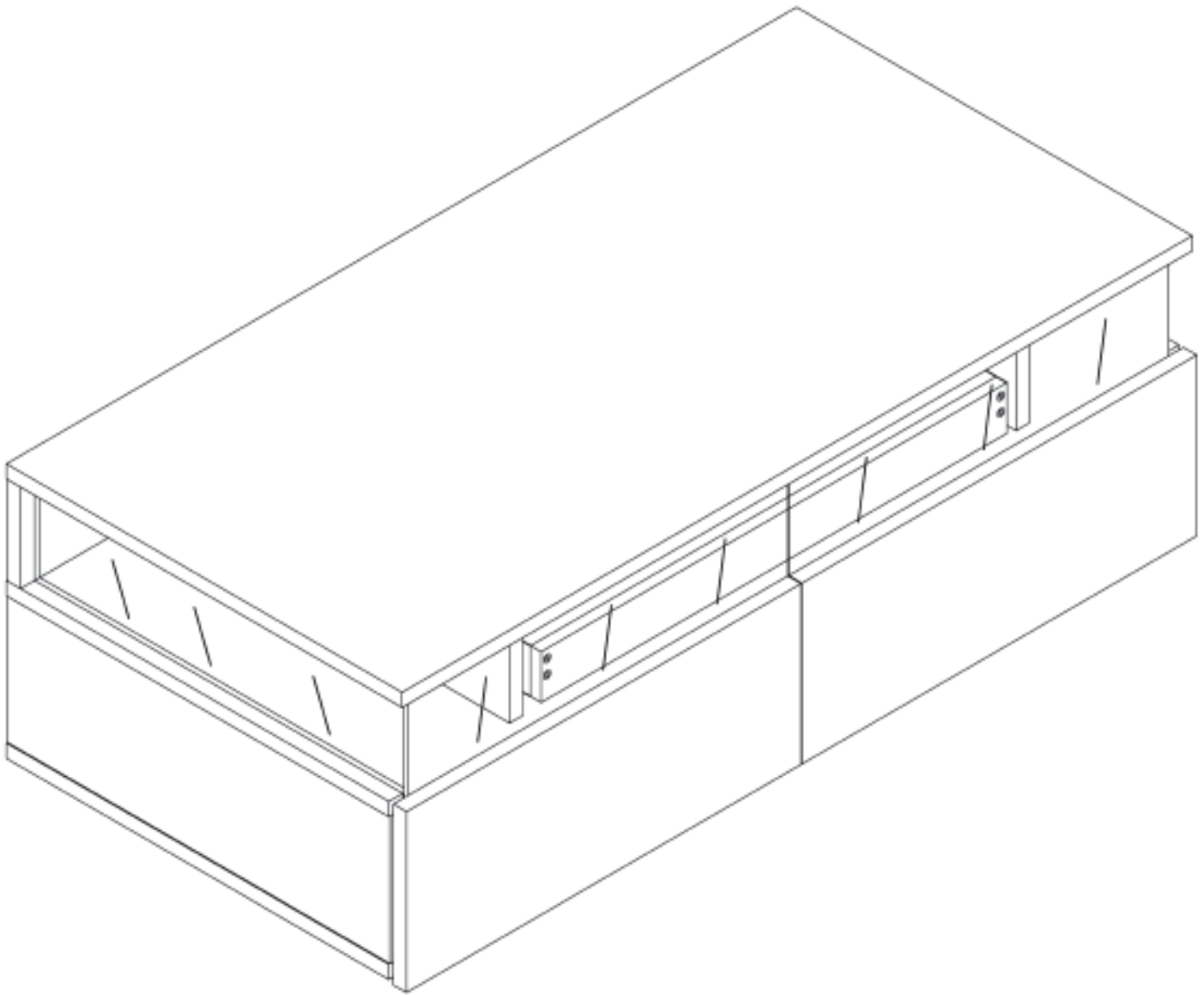





Product manual

Gebrauchsanweisung
Manuel du produit
Manual del producto
Manuale del prodotto

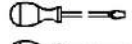

 2PERS	 45 MIN	Tool Required Not Provided	
			



[DE]

Warnung: Lesen Sie die Anleitung vor dem Zusammenbau bitte vollständig durch. Überprüfen Sie, ob Sie alle auf den Seiten aufgeführten Komponenten und Werkzeuge haben.

Warnung: Legen Sie alle Teile auf eine ebene Fläche. Legen Sie eine weiche Decke oder Ähnliches darunter, um sie vor Kratzern oder Flecken zu schützen. Vermeiden Sie es, Komponenten über den Boden zu ziehen oder zu schieben.

Warnung: Überprüfen Sie regelmäßig alle Beschläge und Befestigungen, um sicherzustellen, dass sie sicher sind und um Unfälle zu vermeiden. Wenn Teile fehlen, kaputt, beschädigt oder abgenutzt sind, verwenden Sie das Produkt nicht weiter, bis es mit vom Hersteller autorisierten Teilen repariert wurde.

Warnung: Lassen Sie Kinder nicht auf die Möbel klettern, da dies zum Umkippen und zu schweren Verletzungen führen kann. Bauen Sie die Möbel außerhalb der Reichweite von Kindern zusammen.

Warnung: Stellen Sie die Möbel nicht in die Nähe von Feuerquellen oder heißen Gegenständen, um Brandgefahr zu vermeiden.

Warnung: Reinigen Sie die Möbel mit einem feuchten Tuch oder Alkohol. Verwenden Sie keine Reinigungsmittel mit ätzenden Chemikalien.

[EN]

Warning: Please read instructions fully before starting assembly. Check you have all the components and tools listed on pages.

Warning: Please place all parts on a flat surface. Place a soft blanket or similar underneath to protect against scratches or stains. Avoid dragging or sliding components across the floor.

Warning: Regularly check all fittings and fastenings to ensure they are secure and to prevent accidents. If any parts are missing, broken, damaged, or worn, discontinue use of the product until repairs have been made using factory authorized parts.

Warning: Do not allow children to climb on the furniture as this may result in tipping and serious personal injury. Assemble the furniture away from the reach of children.

Warning: Do not place furniture close to fire sources or high-temperature objects to avoid the risk of fire.

Warning: Clean furniture with a damp cloth or alcohol, avoid using cleaning agents containing corrosive chemicals.

[FR]

Avertissement : Veuillez lire entièrement les instructions avant de commencer l'assemblage. Vérifiez que vous disposez de tous les composants et outils répertoriés sur les pages.

Avertissement : Veuillez placer toutes les pièces sur une surface plane. Placez une couverture douce ou similaire en dessous pour les protéger des rayures ou des taches. Évitez de faire glisser les composants sur le sol.

Avertissement : Vérifiez régulièrement tous les raccords et fixations pour vous assurer qu'ils sont bien fixés et pour éviter les accidents. Si des pièces manquent, sont cassées, endommagées ou usées, cessez d'utiliser le produit jusqu'à ce que des réparations aient été effectuées à l'aide de pièces autorisées par l'usine.

Avertissement : Ne laissez pas les enfants grimper sur les meubles car cela pourrait entraîner un basculement et des blessures graves. Assemblez les meubles hors de portée des enfants.

Avertissement : Ne placez pas les meubles à proximité de sources de feu ou d'objets à haute température pour éviter tout risque d'incendie.

Avertissement : Nettoyez les meubles avec un chiffon humide ou de l'alcool, évitez d'utiliser des produits de nettoyage contenant des produits chimiques corrosifs.



[IT]

Attenzione: leggere attentamente le istruzioni prima di iniziare il montaggio. Verificare di avere tutti i componenti e gli strumenti elencati nelle pagine.

Attenzione: posizionare tutte le parti su una superficie piana. Posizionare una coperta morbida o simile sotto per proteggere da graffi o macchie. Evitare di trascinare o far scivolare i componenti sul pavimento.

Attenzione: controllare regolarmente tutti i raccordi e i dispositivi di fissaggio per assicurarsi che siano sicuri e per prevenire incidenti. Se alcune parti sono mancanti, rotte, danneggiate o usurate, interrompere l'uso del prodotto fino a quando non siano state eseguite le riparazioni utilizzando parti autorizzate dalla fabbrica.

Attenzione: non consentire ai bambini di arrampicarsi sui mobili poiché ciò potrebbe causare ribaltamenti e gravi lesioni personali. Montare i mobili lontano dalla portata dei bambini.

Attenzione: non posizionare i mobili vicino a fonti di fuoco o oggetti ad alta temperatura per evitare il rischio di incendio.

Attenzione: pulire i mobili con un panno umido o alcol, evitare di utilizzare detergenti contenenti sostanze chimiche corrosive.

[ES]

Advertencia: Lea las instrucciones completamente antes de comenzar el montaje. Compruebe que tiene todos los componentes y herramientas que se enumeran en las páginas.

Advertencia: Coloque todas las piezas sobre una superficie plana. Coloque una manta suave o algo similar debajo para protegerlas de rayones o manchas. Evite arrastrar o deslizar los componentes por el piso.





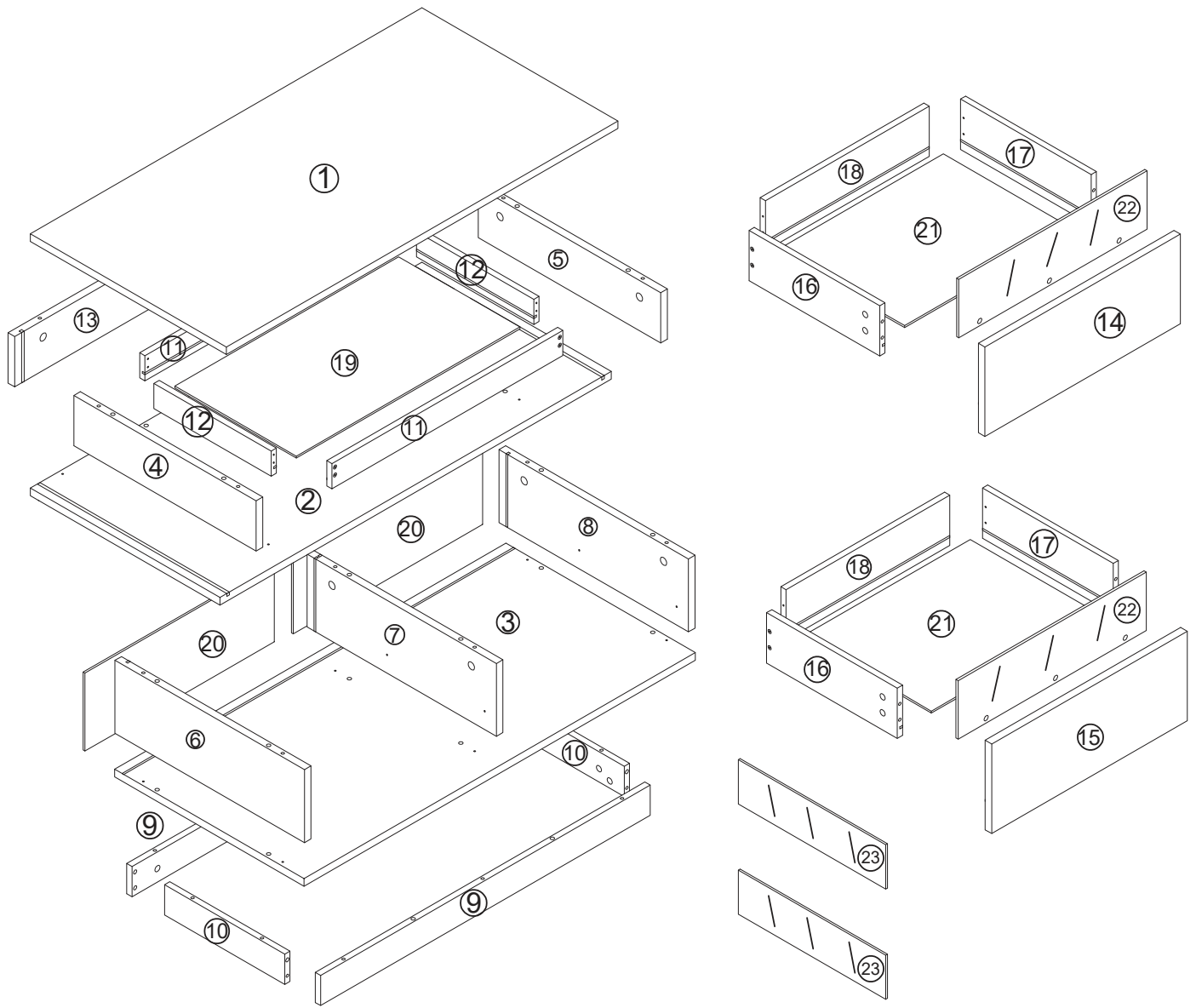

Advertencia: Verifique regularmente todos los accesorios y fijaciones para asegurarse de que estén seguros y evitar accidentes. Si falta alguna pieza, está rota, dañada o desgastada, deje de usar el producto hasta que se hayan realizado las reparaciones con piezas autorizadas de fábrica.

Advertencia: No permita que los niños se suban a los muebles, ya que esto puede provocar que se vuelquen y lesiones personales graves. Monte los muebles fuera del alcance de los niños.

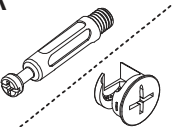
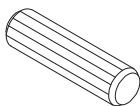
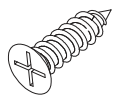
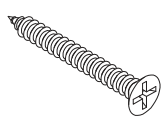
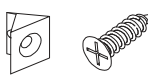
Advertencia: No coloque los muebles cerca de fuentes de fuego u objetos de alta temperatura para evitar el riesgo de incendio.

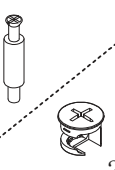
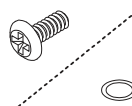
Advertencia: Limpie los muebles con un paño húmedo o alcohol, evite usar agentes de limpieza que contengan químicos corrosivos.

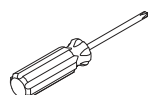

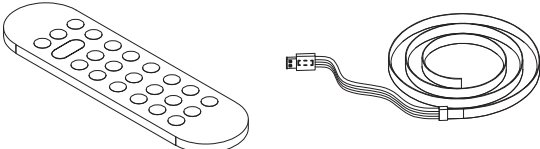
<p>A</p>  <p>13PCS</p>	<p>B 8*40</p>  <p>24PCS</p>	<p>C $\phi 3.5 \times 12$</p>  <p>26PCS</p>	<p>D $\phi 3.5 \times 30$</p>  <p>29PCS</p>	<p>E $\phi 3.5 \times 12$</p>  <p>7PCS</p>	<p>F 6*30</p>  <p>8PCS</p>
<p>G</p>  <p>22PCS</p>	<p>H $\phi 6 \times 15$</p>  <p>6PCS</p>	<p>I</p> <ul style="list-style-type: none"> CL CR DL DR <p>2SETS</p>	<p>J</p>  <p>16PCS</p>	<p>K</p>  <p>1PCS</p>	<p>L</p>  <p>10PCS</p>
<p>M</p>  <p>1PCS</p>					

BOX 1-1	
1	899*450*15=1
2	899*435*15=1
3	899*435*15=1
4	409*100*15=1
5	409*100*15=1
6	435*145*15=1
7	435*145*15=1
8	435*145*15=1
9	757*60*12=2
10	276*60*12=2
11	530*50*12=2
12	269*50*12=2
13	899*100*15=1
14	449*178*15=1
15	449*178*15=1
16	300*100*15=2
17	300*100*15=2
18	376*100*15=2
19	514*279*3=1
20	435*155*3=2
21	386*297*3=2
22	432*133*5=2
23	419*109*5=2

465*150*40

Hardware fittings

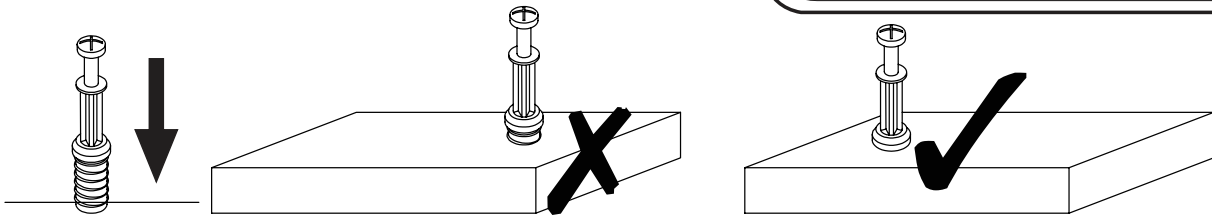

EN_QUICKFIT:Tighten quickfit until shoulder is flush with panel.Do not overtighten or undertighten.

FR_RACCORD RAPIDE:Faites serrer le raccord rapide jusqu'à ce que l'épaulement soit parfaitement encastré dans le panneau. Il ne faut ni trop serrer ni insuffisamment serrer.

ES_QUICKFIT:Apriete quickfit hasta que el hombro se descargue con el panel. NO lo sobreapriete ni lo apriete poco.

DE_QUICKFIT:Ziehen Sie den Quickfit fest, bis die Schulter mit der Platte bündig ist. Bitte nicht zu fest oder zu schwach anziehen.

IT_MONTAGGIO RAPIDO:Stringere il montaggio rapido fino a quando la spalla è a filo con il pannello, non stringere troppo o troppo poco.

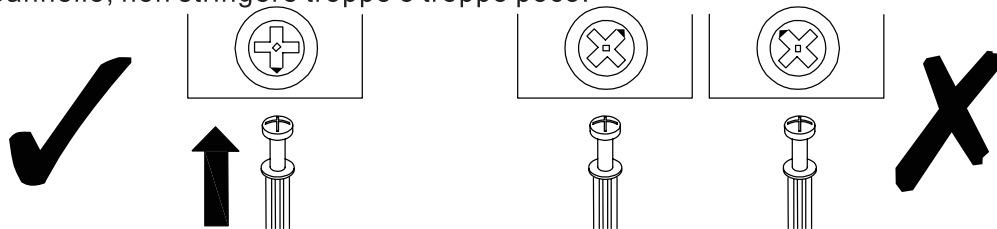

EN_CAM LOCK:When fitting cam lock, ensure starting position is correct before you insert connecting quickfit.

FR_SERRURE BATTEUSE:Avant d'insérer la serrure batteuse, veuillez à la bonne orientation avant d'insérer le raccord rapide.

ES_CIERRE DE LA CÁMARA:Cuando instale el cierre de la cámara, asegúrese de que la posición de inicio es correcta antes de que inserte el quickfit conector.

DE_CAM-LOCK:Achten Sie bei der Montage des Cam-Locks auf die richtige Ausgangsposition, bevor Sie den Quickfit einsetzen.

IT_BLOCCAGGIO A CAMMA:Quando si monta il bloccaggio a camma, assicurarsi che la posizione iniziale sia corretta prima di inserire il montaggio rapido di collegamento.

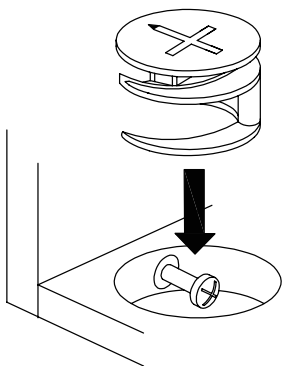

EN_Quickfit head should be in the centre of the cam lock when the two panels are joined.

Cam lock should be inserted before quickfit.

FR_Lorsque les deux panneaux sont assemblés, la tête du raccord rapide doit reposer au centre de la serrure batteuse.

Il faut insérer la serrure batteuse avant le raccord rapide.

ES_El cabezal del quickfit debe estar en el centro del cierre de la cámara cuando se unan los dos paneles.

Se debe insertar el cierre de la cámara antes que el quickfit.

DE_Der Quickfit-Kopf sollte sich in der Mitte des Cam-Locks befinden, wenn die beiden Platten zusammengefügt sind.

Der Cam-Lock sollte vor dem Quickfit eingesetzt werden.

IT_La testa del montaggio rapido deve trovarsi al centro del bloccaggio a camma quando i due pannelli sono uniti.

Il Bloccaggio a Camma deve essere inserito prima del montaggio rapido.

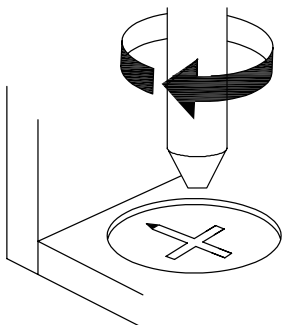

EN_Turn cam lock clockwise to tighten.

FR_Faites tourner la serrure batteuse dans le sens des aiguilles d'une montre pour la resserrer.

ES_Gire el cierre de la cámara en sentido horario para apretarlo.

DE_Drehen Sie den Cam-Lock im Uhrzeigersinn, um ihn festzuziehen.

IT_Ruotare il bloccaggio a camma in senso orario per stringere.

1

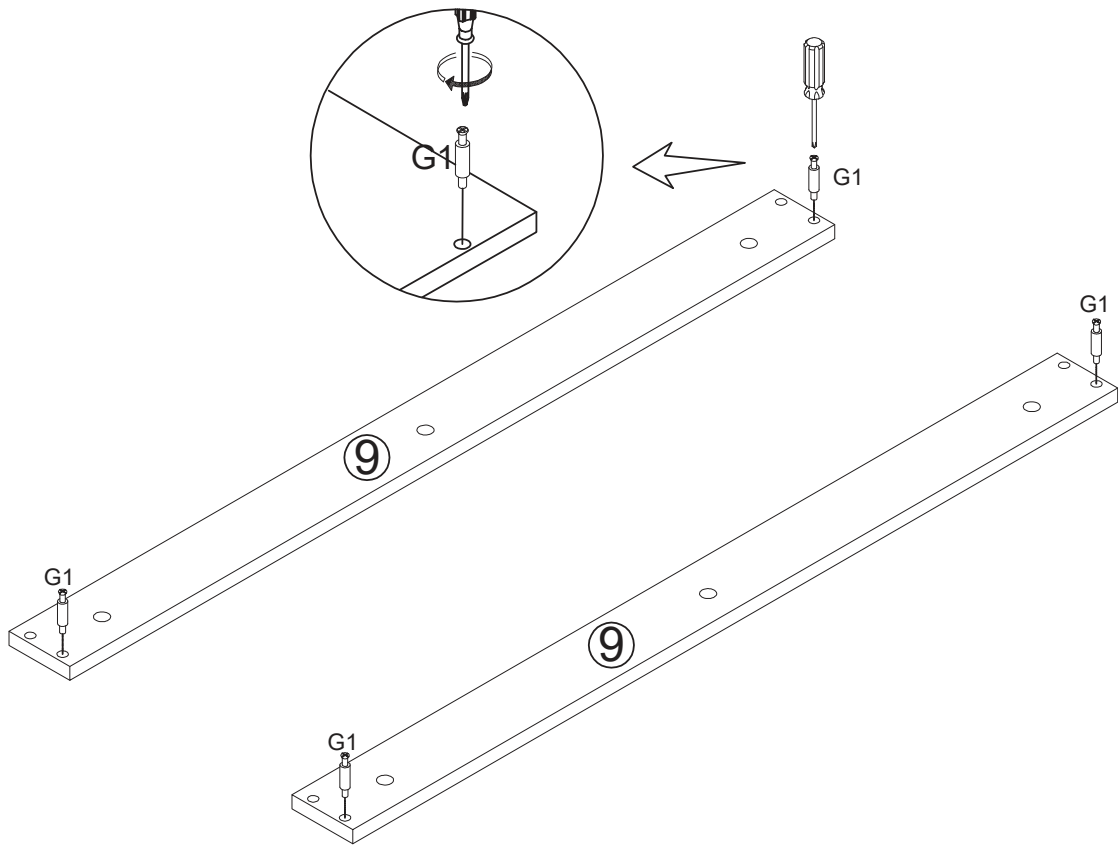

G1
4PCS

2

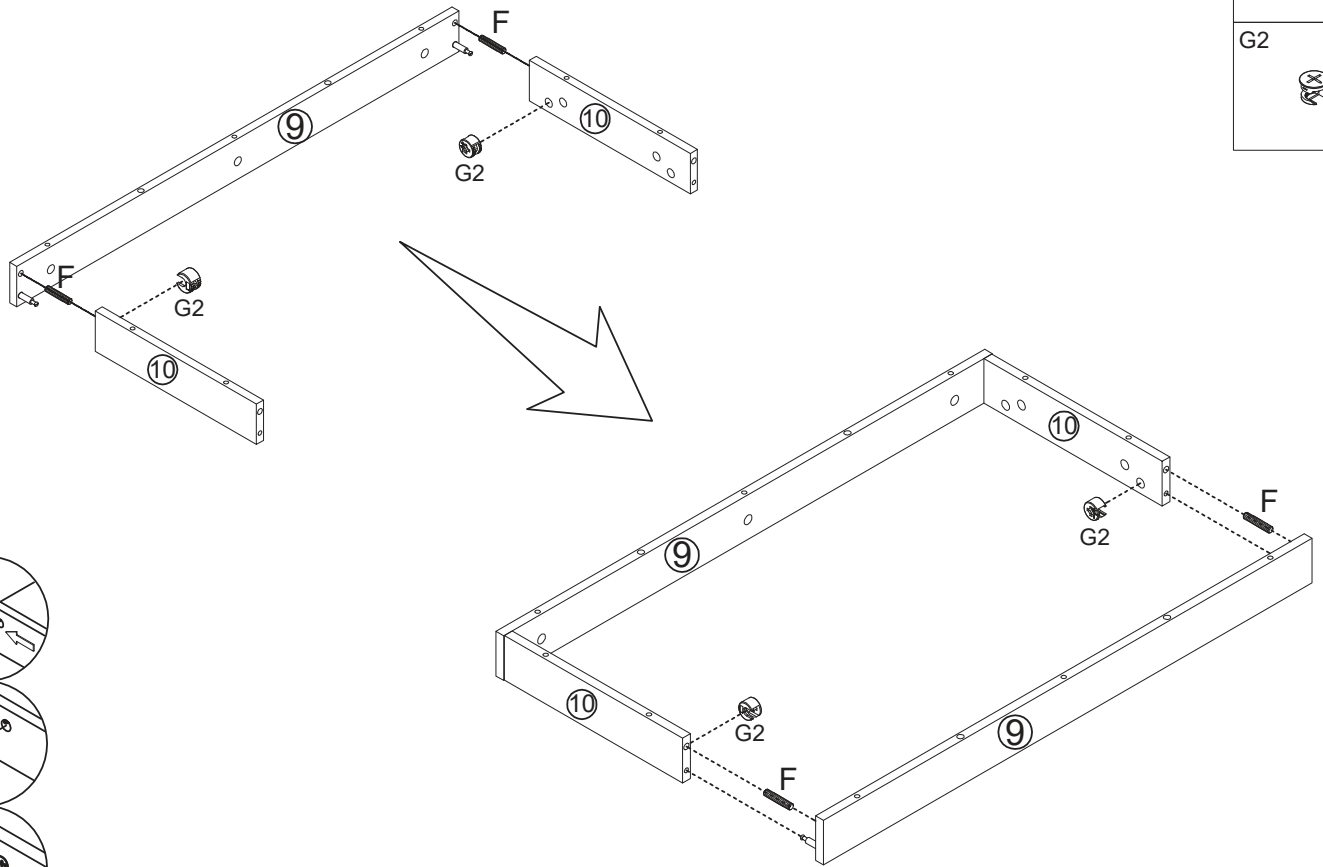

F 6*30
4PCS

G2
4PCS

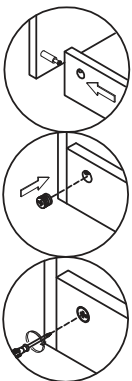

3

G1
10PCS

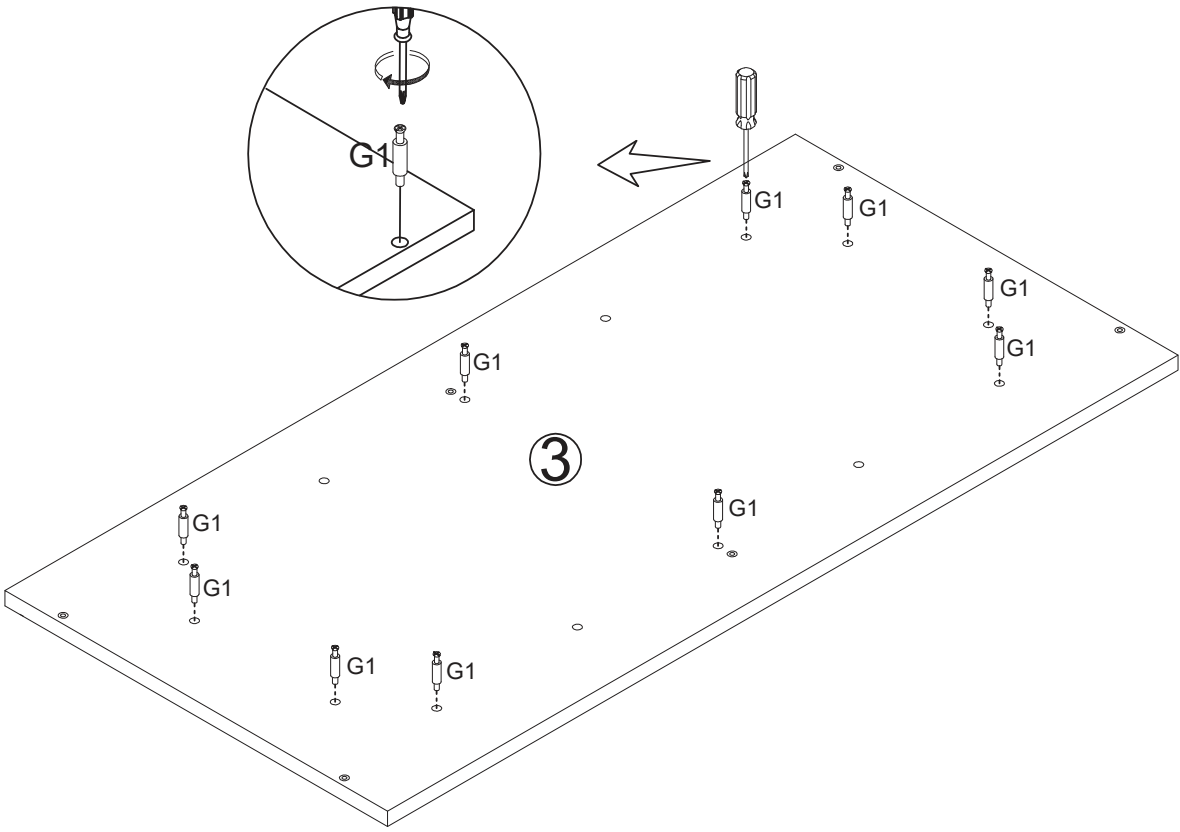

4

F
6*30
4PCS

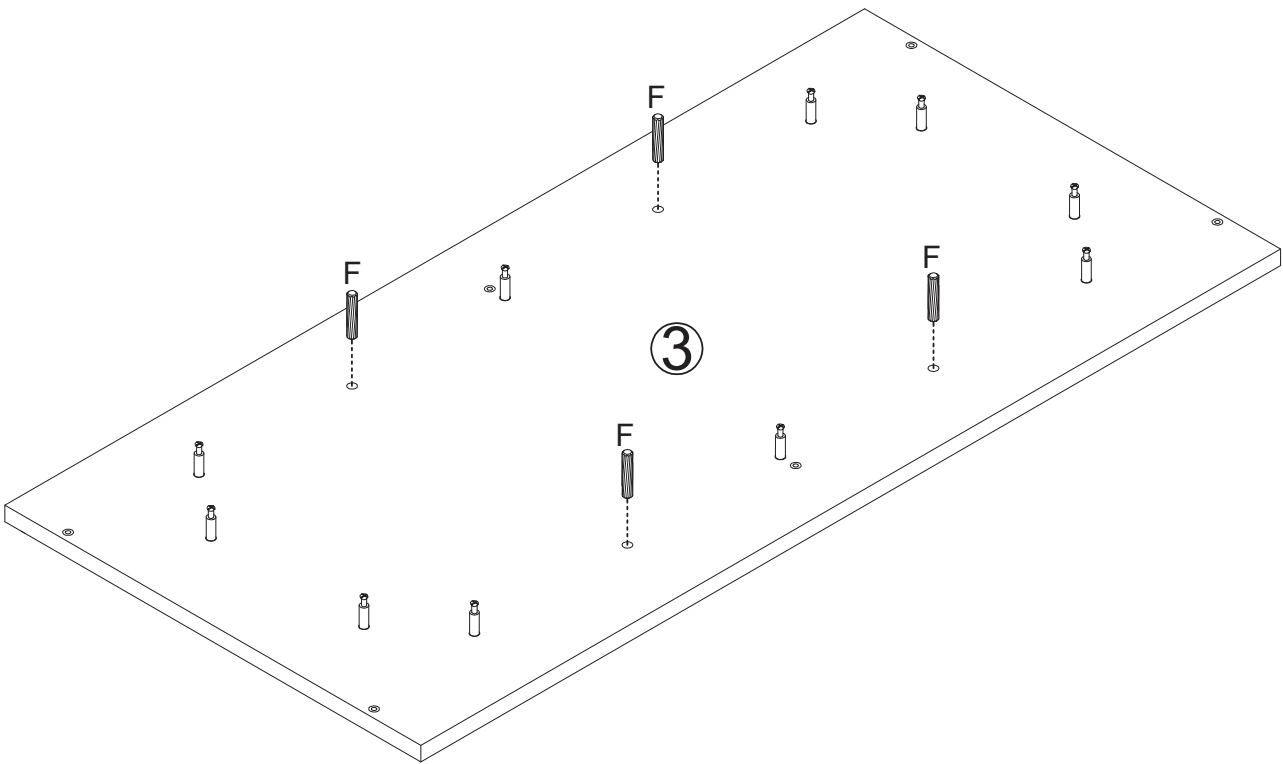

5

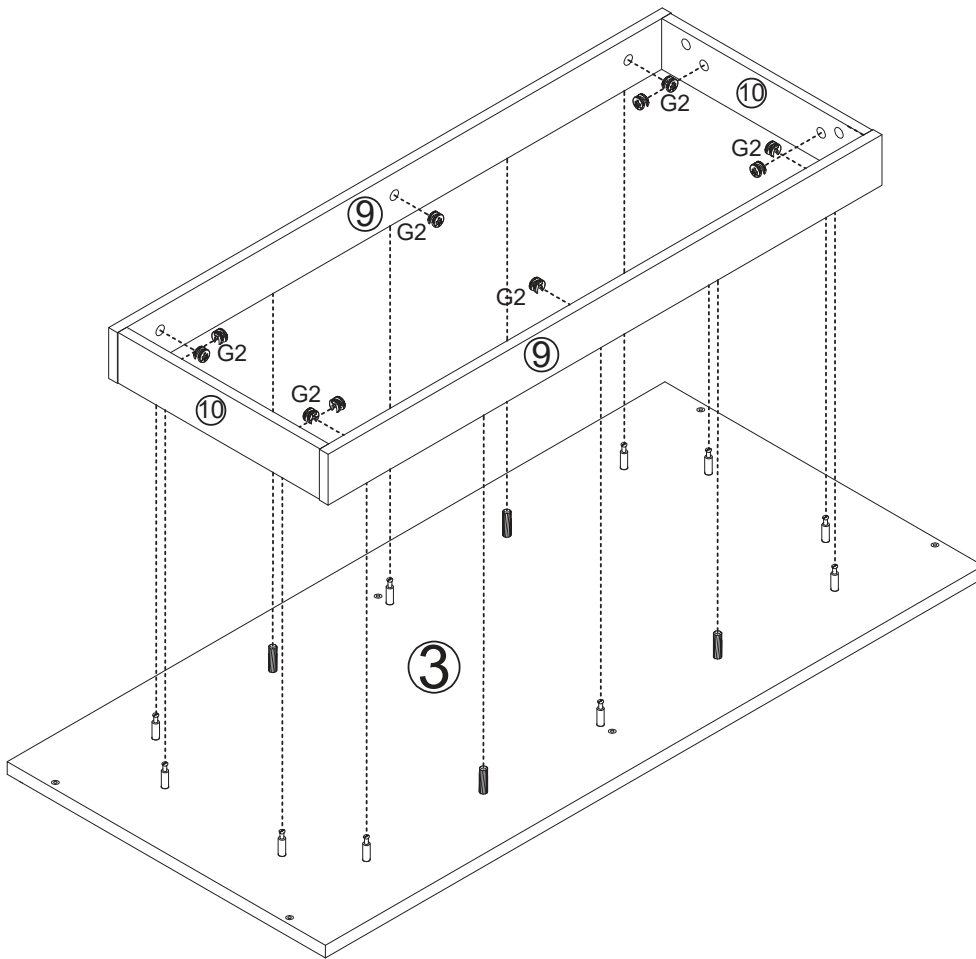

G2



10PCS

6

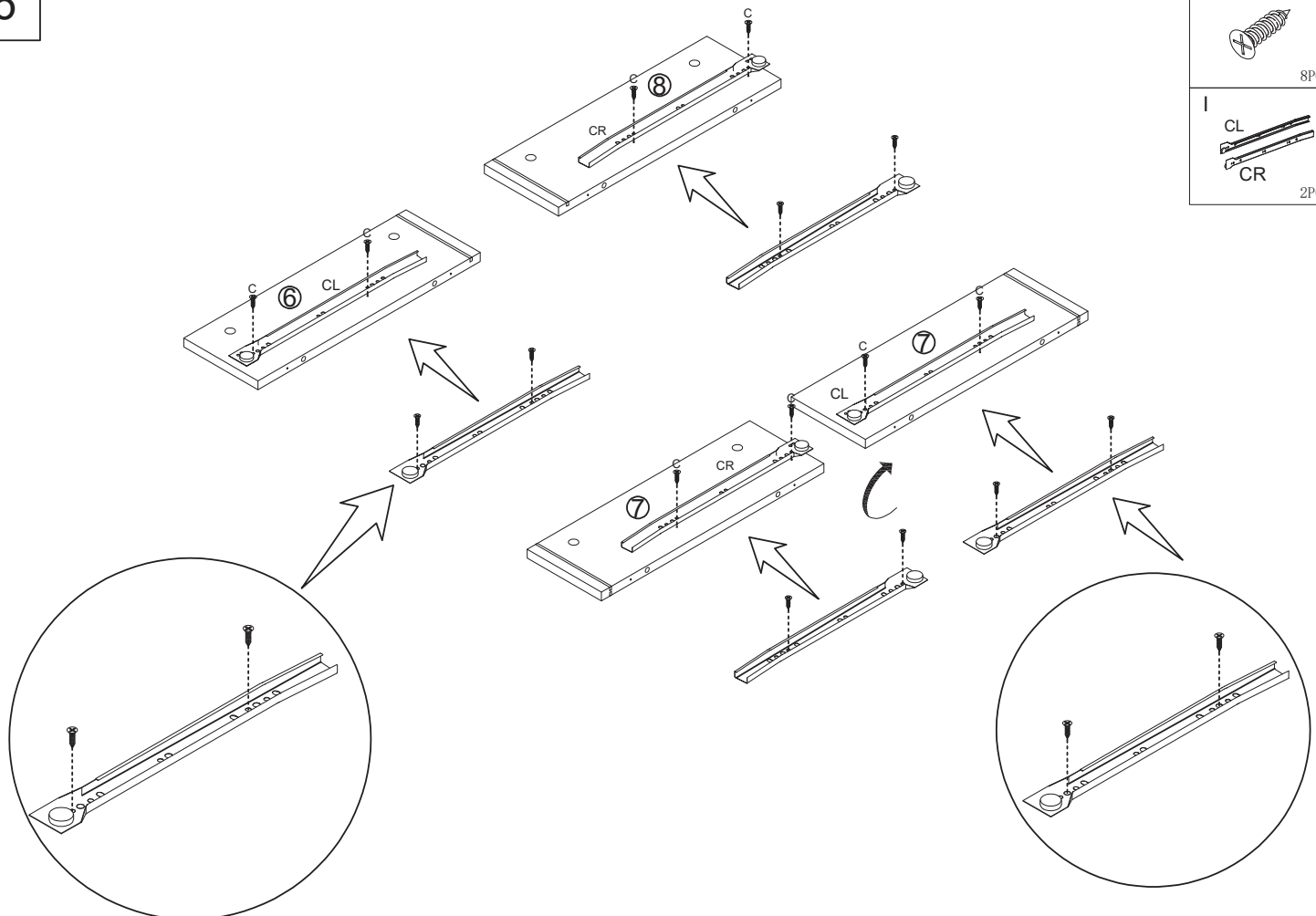

C

Ø3.5x12



8PCS

I



2PCS

CL

CR

7

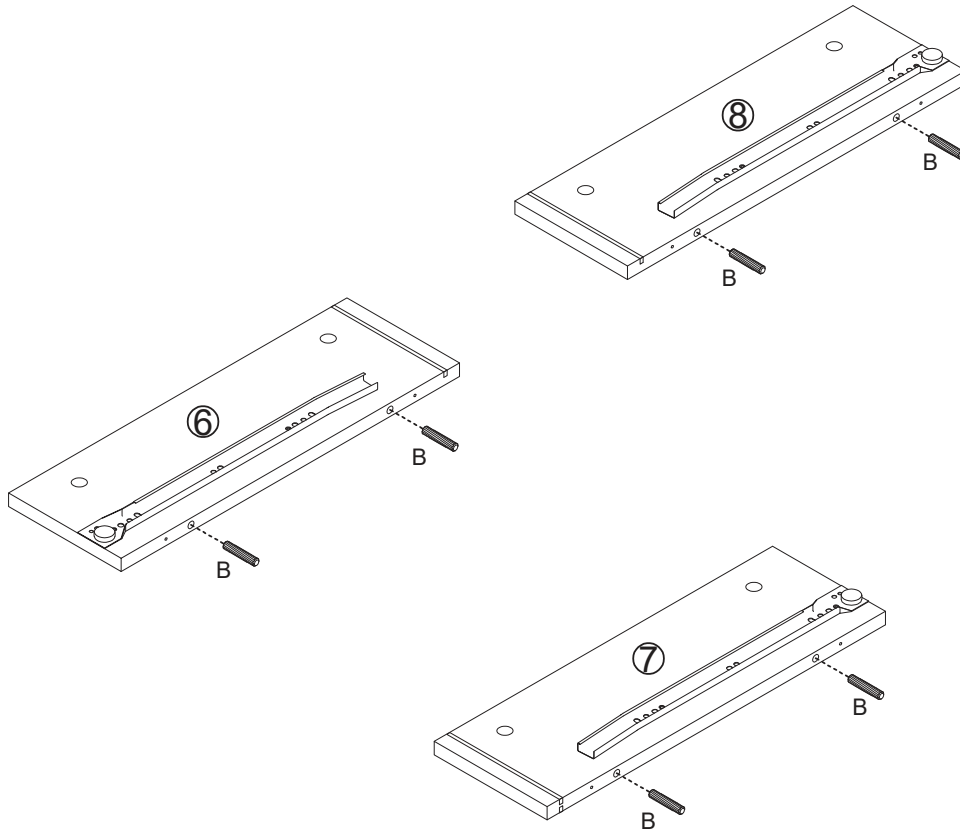
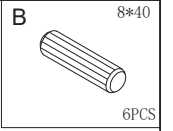

8

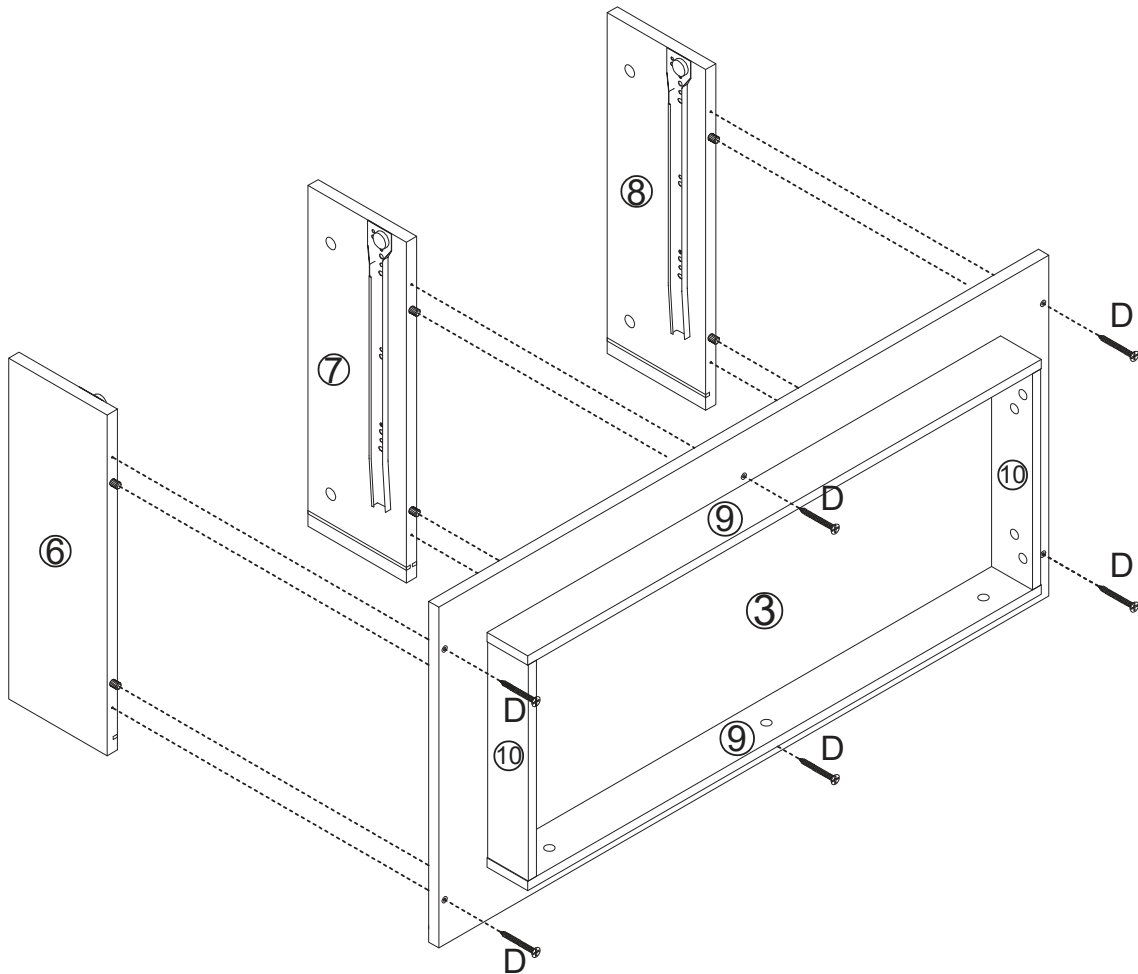
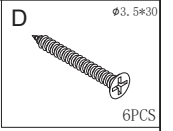

9

B 8*40
6PCS

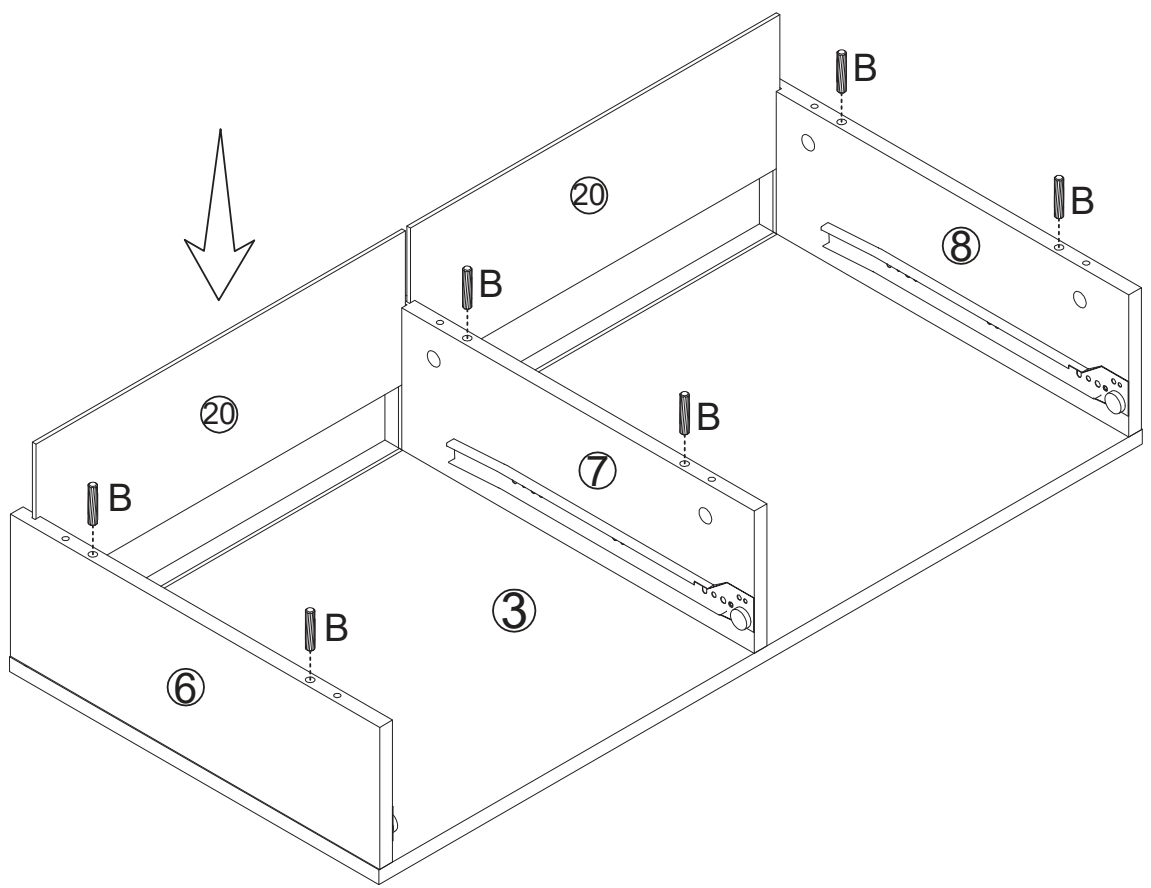

10

B 8*40
6PCS

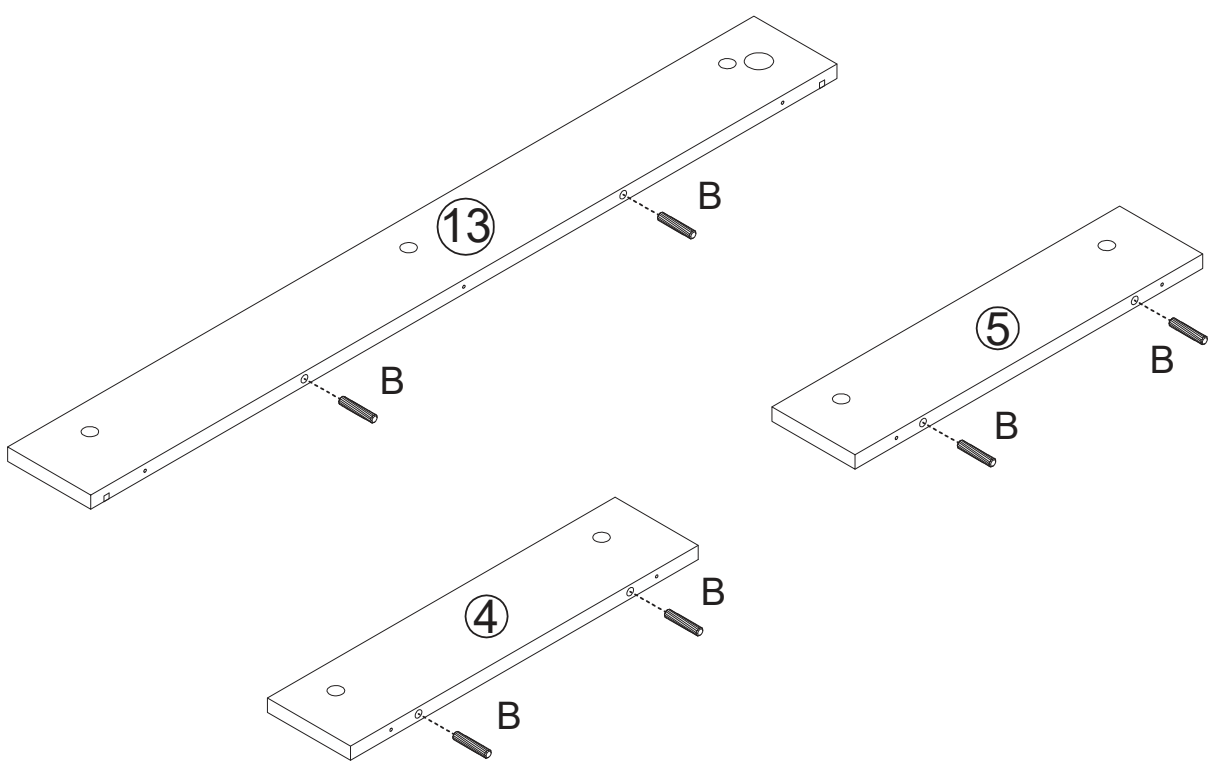

11

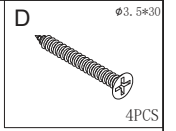
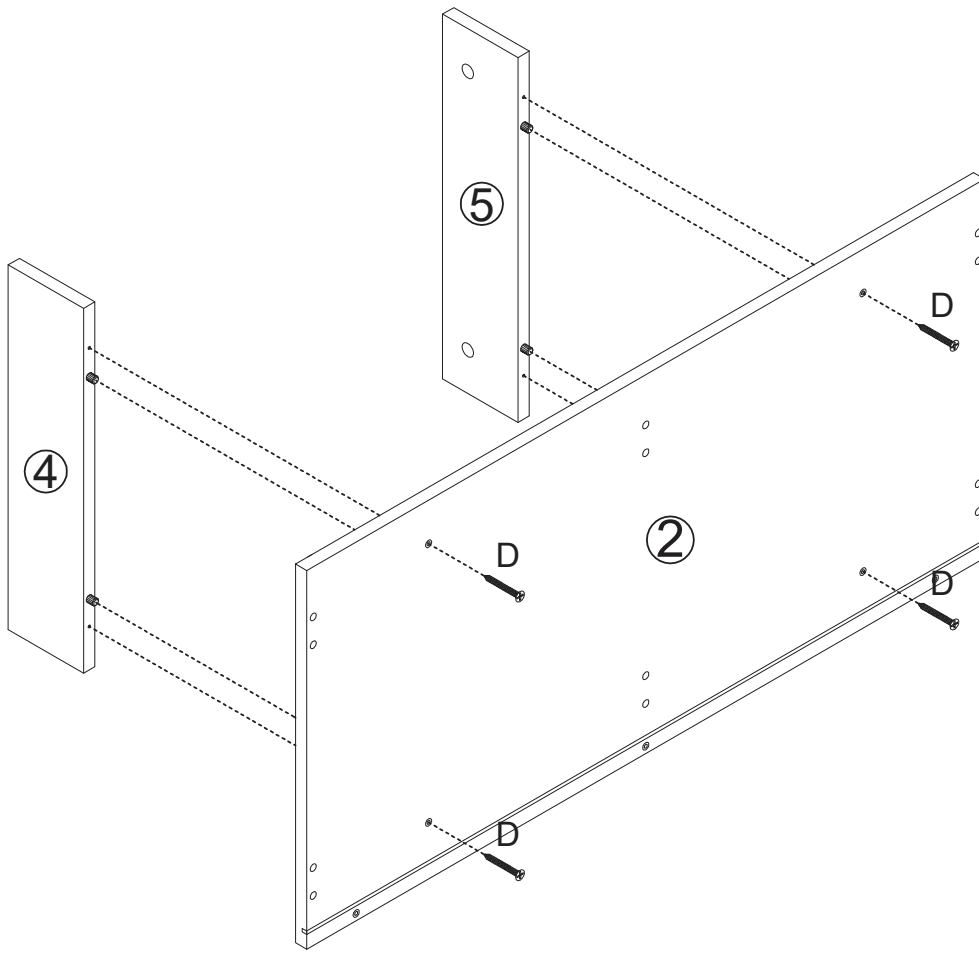

12

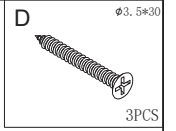
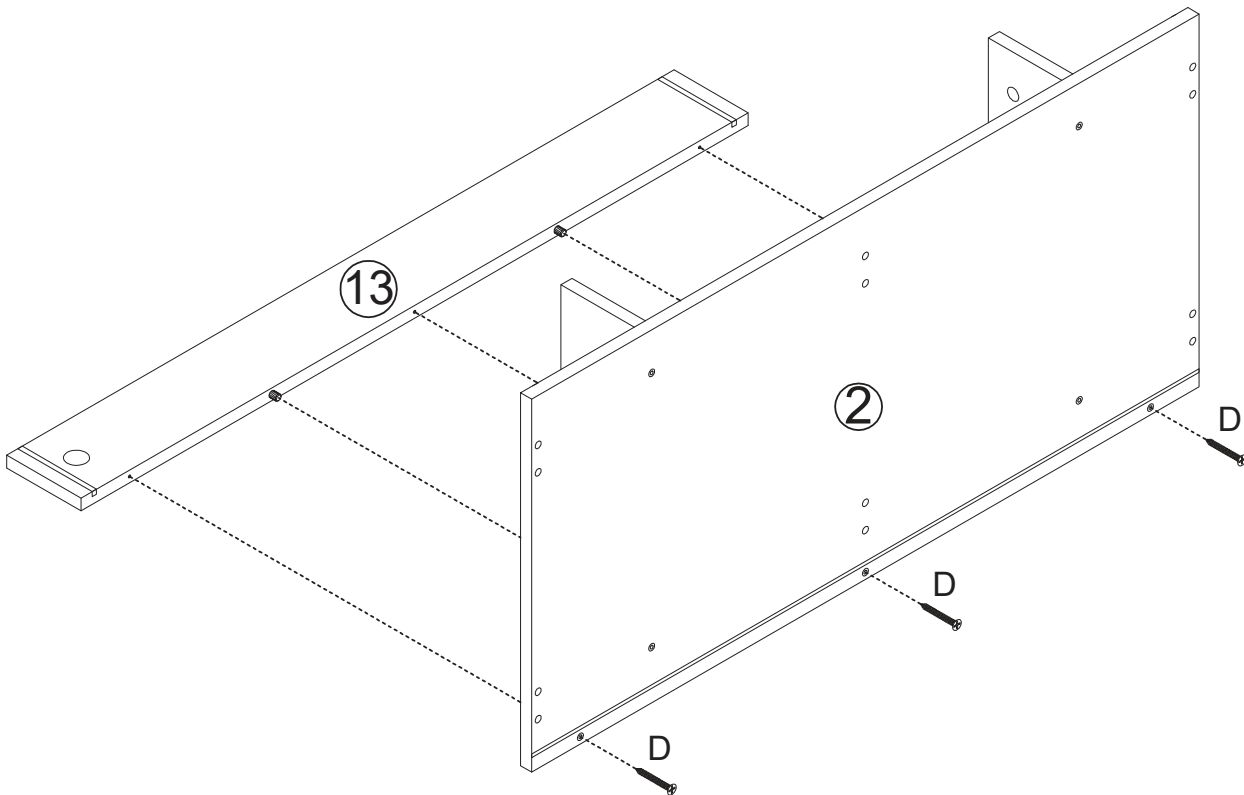

13

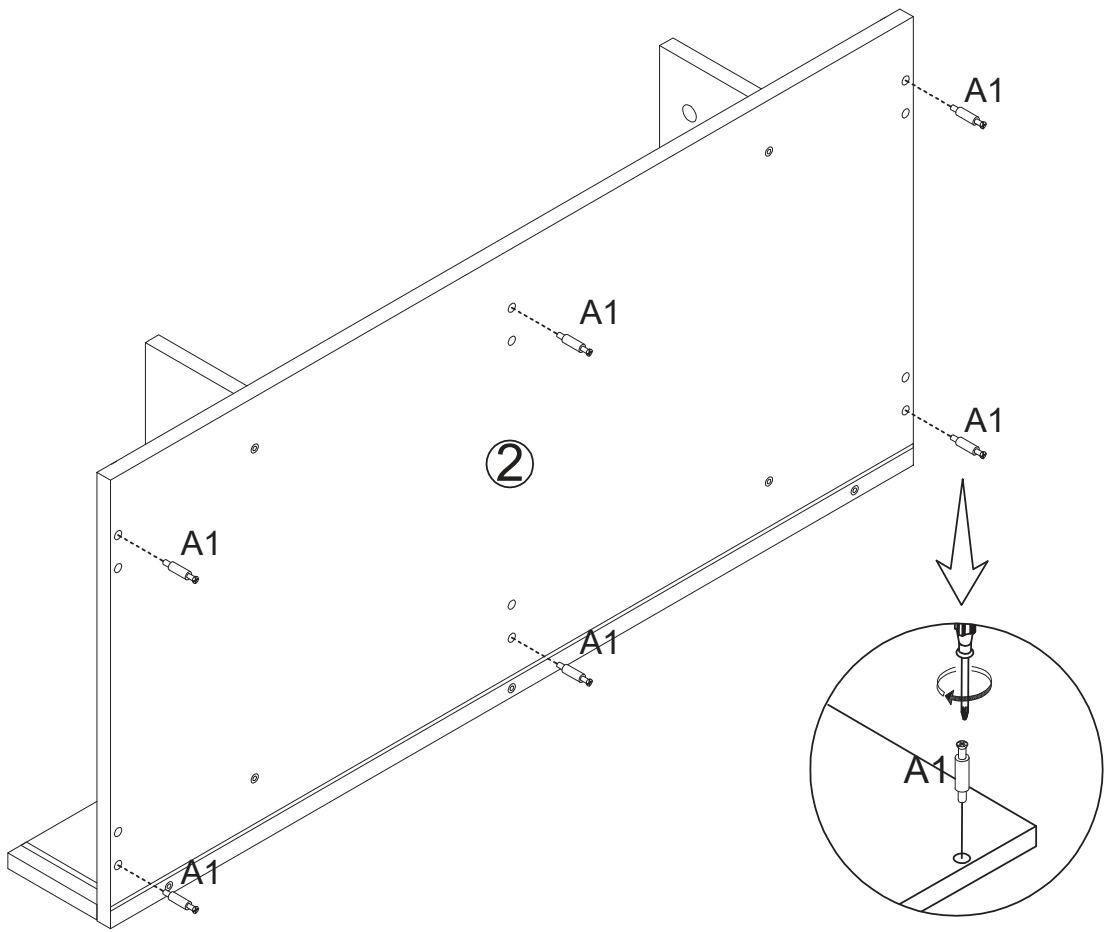

A1
6PCS

14

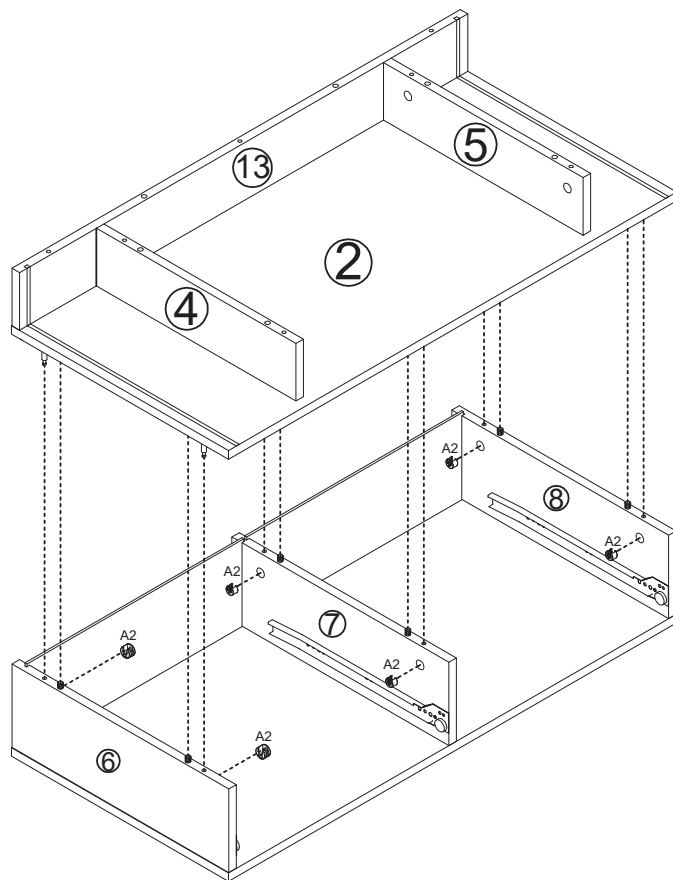

A2
6PCS

15

B 8*40
6PCS

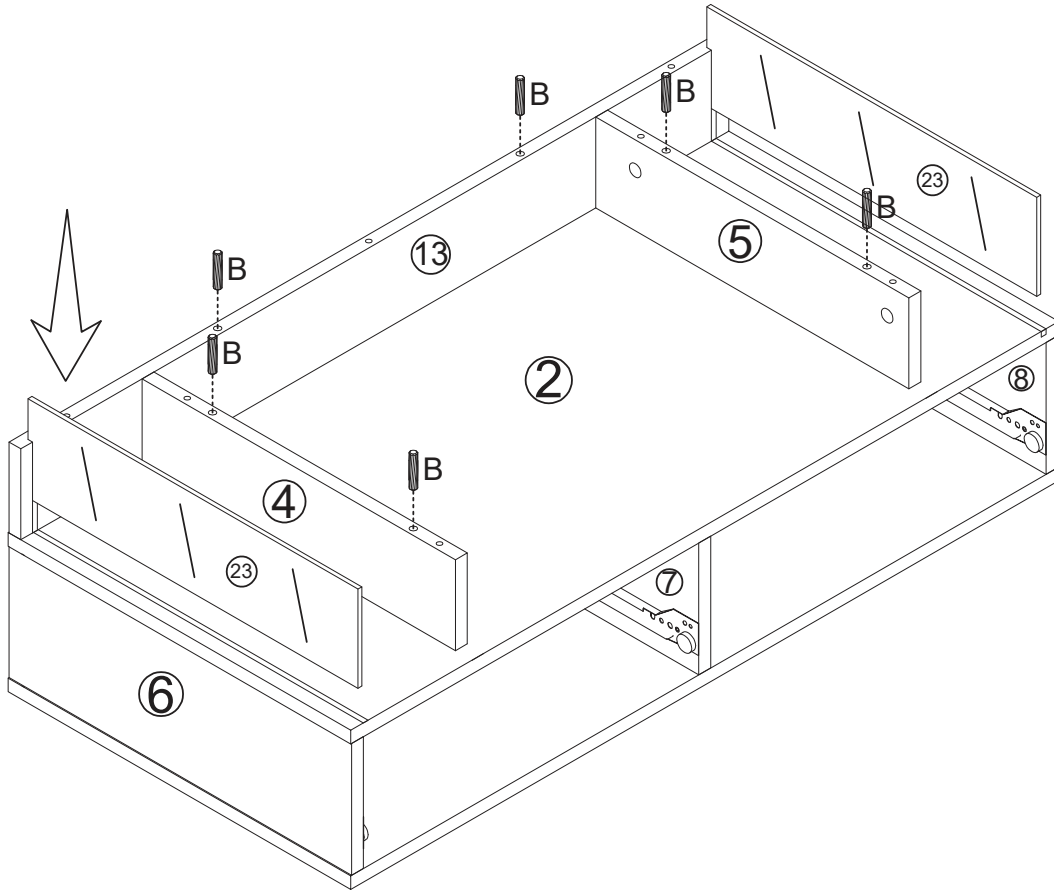

16

A1 7PCS

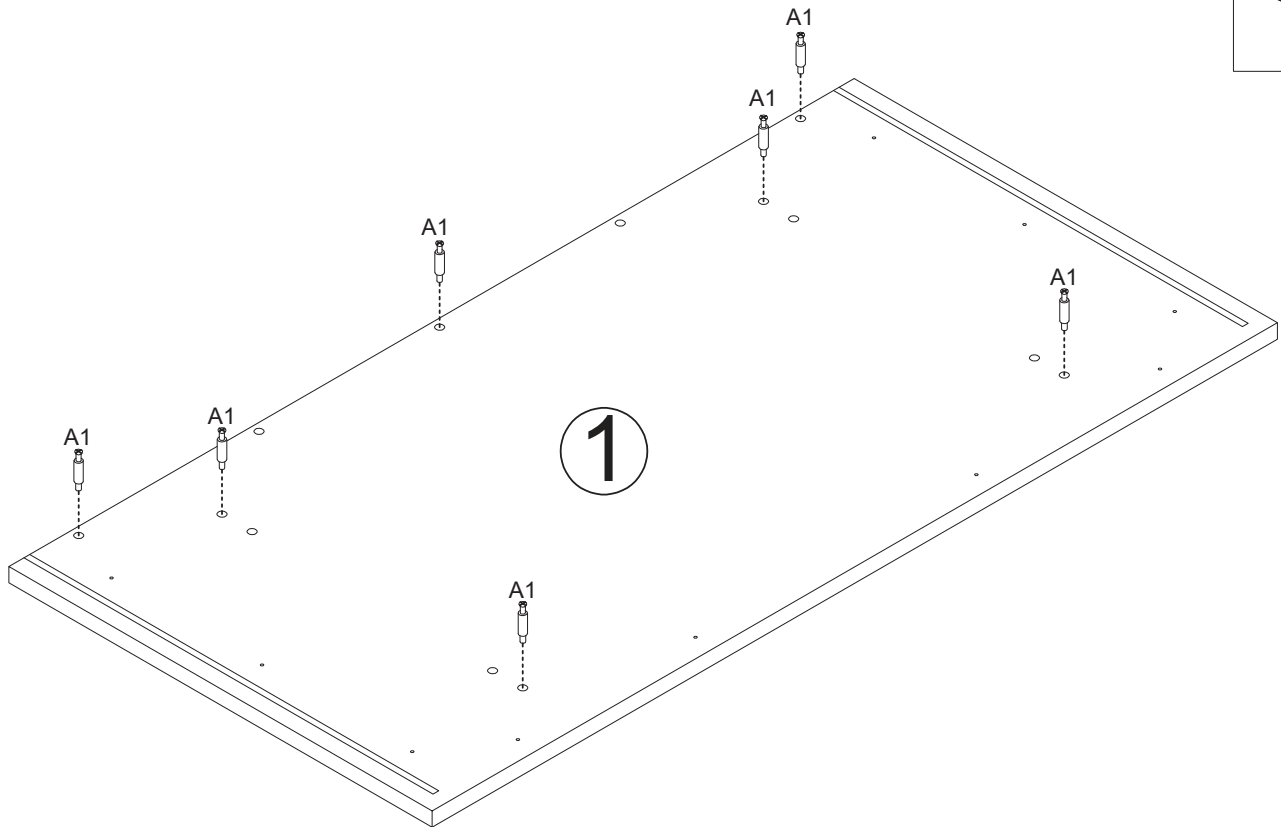

17

DE: "Scannen Sie den QR-Code, um die App zur Steuerung des LED-Lichts herunterzuladen." UK: "Scan the QR code to download the app to control the LED light."

IT: "Scansiona il codice QR per scaricare l'app per controllare la luce LED."

FR: "Scannez le code QR pour télécharger l'application afin de contrôler la lumière LED." ES: "Escanea el código QR para descargar la aplicación y controlar la luz LED."

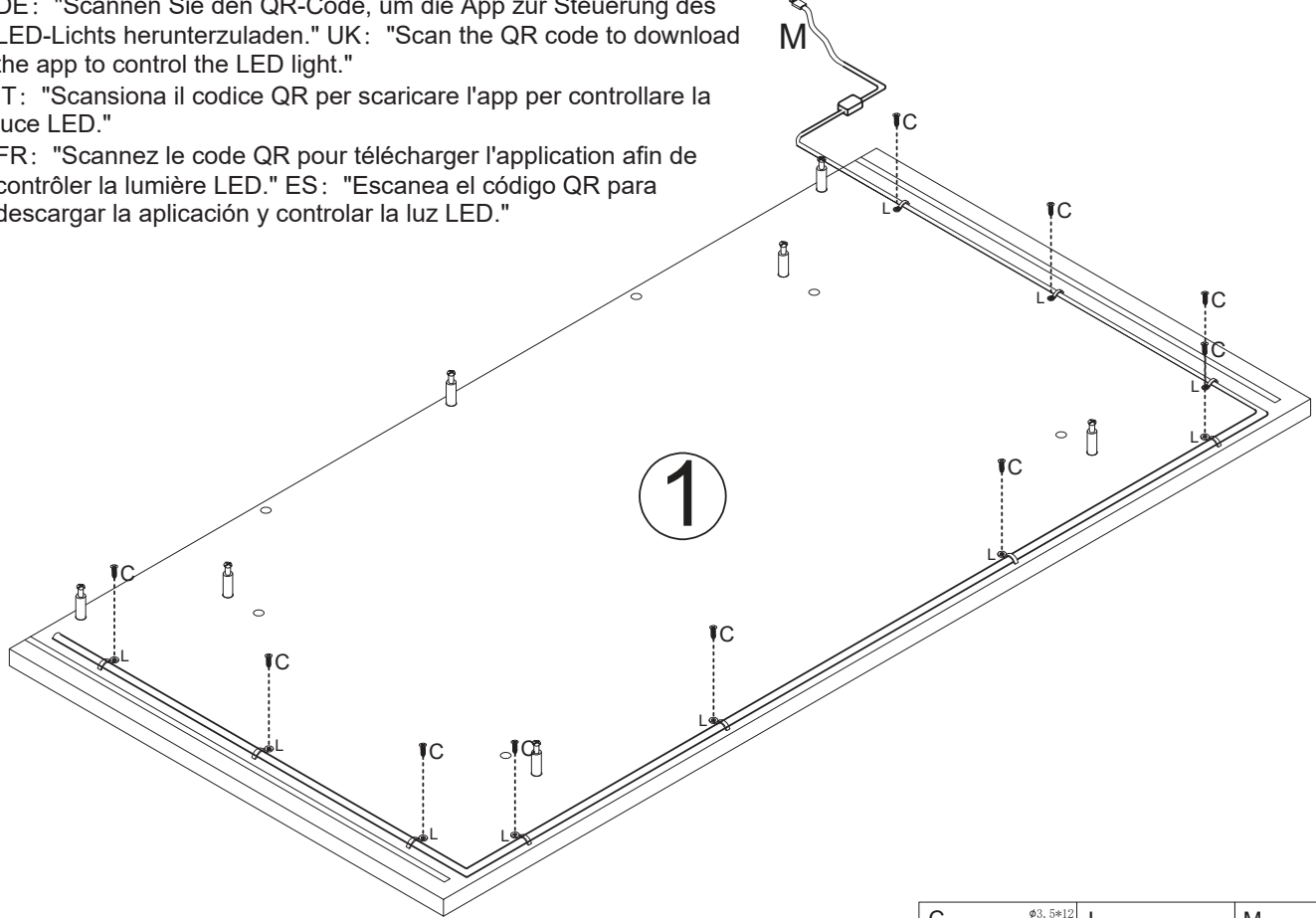

<p>C</p>  <p>10PCS</p>	<p>L</p>  <p>10PCS</p>	<p>M</p>  <p>1PCS</p>
--	--	---

18

<p>A2</p>  <p>7PCS</p>

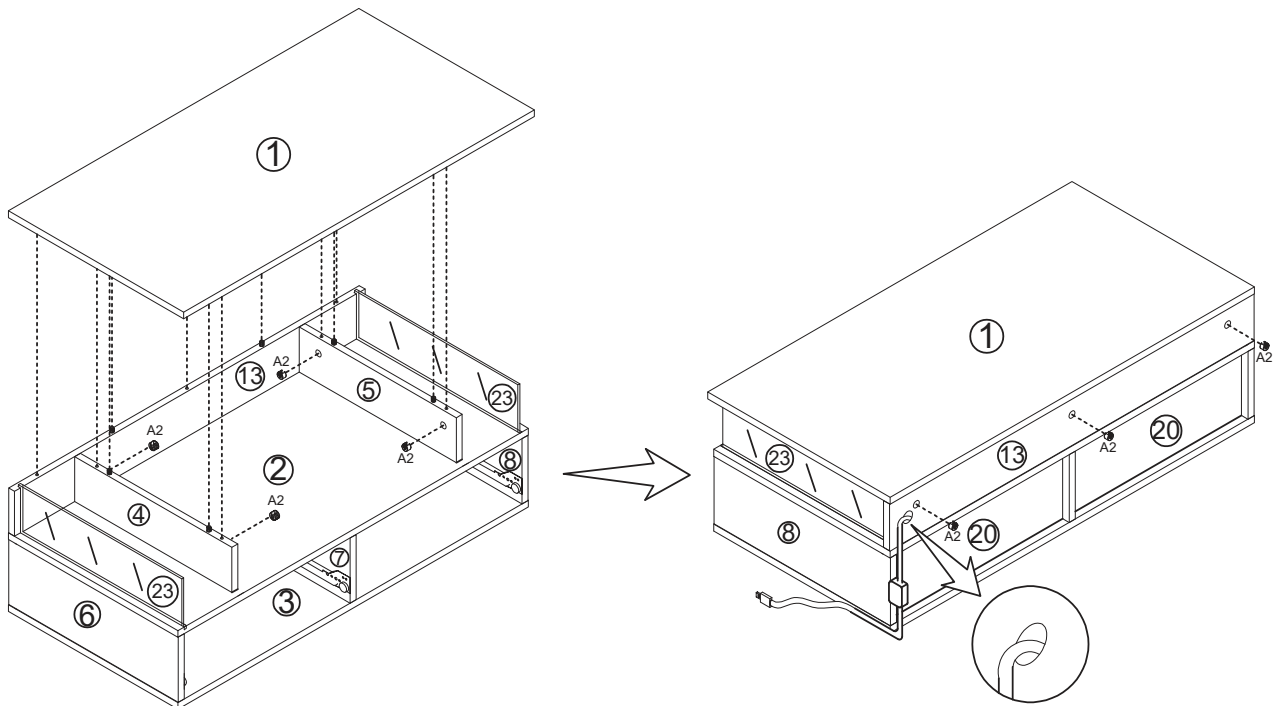

Attention: Lead out the light strip plug from this circular hole

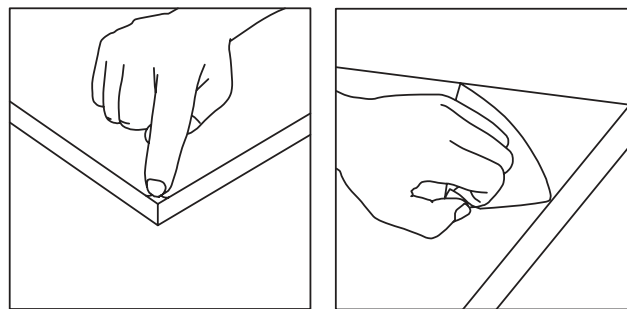
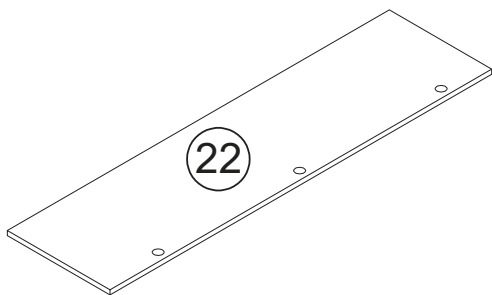
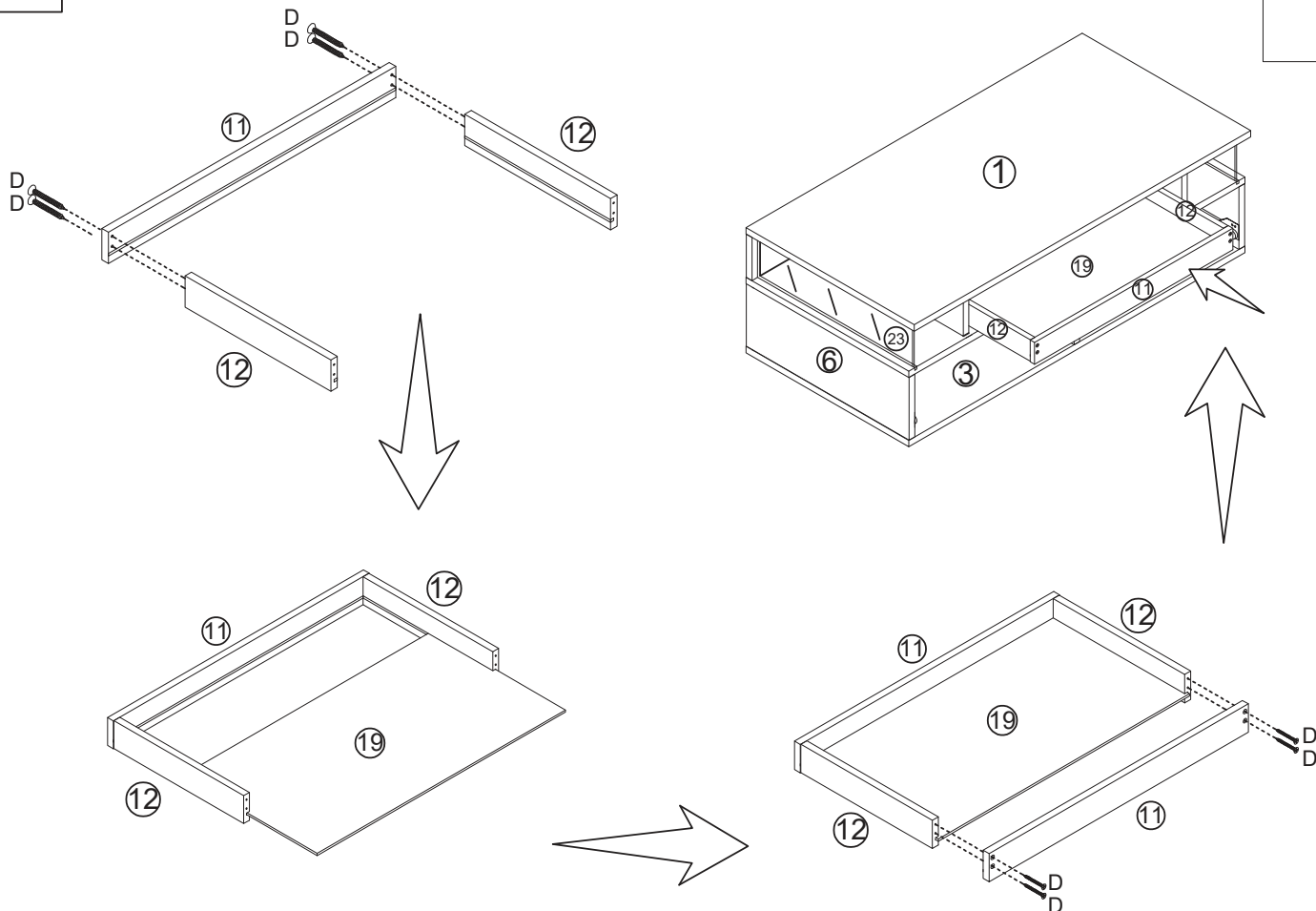

[DE]

BITTE BEACHTEN: Teilenummer 22 ist mit einer dichten Kunststoffschutzfolie überzogen.

Wenn das Produkt nach der Demontage Kratzer aufweist, machen Sie sich bitte keine Sorgen, es handelt sich nicht um einen Produktschaden. Bitte ziehen Sie die schützende Kunststofffolie langsam entlang der Kante von der Oberfläche ab.

Nach dem Abziehen wird das Produkt glatt und sauber.

[EN]

PLEASE NOTE: Part number 22 are covered with a tight plastic protective film.

If there are scratches on the product after disassembly, please don't worry, it's not product damage. Please slowly tear off the protective plastic film on the surface along the edge.

After peeling off, the product becomes smooth and clean.

[FR]

REMARQUE: les pièces numéro 22 sont recouvertes d'un film protecteur en plastique étanche. Si le produit présente des rayures après le démontage, ne vous inquiétez pas, il ne s'agit pas d'un dommage au produit. Retirez lentement le film protecteur en plastique sur la surface le long du bord. Une fois décollé, le produit devient lisse et propre.

[IT]

NOTA BENE: Il numero di parte 22 è coperto da una pellicola protettiva in plastica stretta.

Se ci sono graffi sul prodotto dopo lo smontaggio, non preoccuparti, non è un danno al prodotto. Strappare lentamente la pellicola protettiva in plastica sulla superficie lungo il bordo. Dopo averla staccata, il prodotto diventa liscio e pulito.

[ES]

NOTA: La pieza número 22 está cubierta con una película protectora de plástico.

Si hay rayones en el producto después de desmontarlo, no se preocupe, no se trata de daños en el producto. Retire lentamente la película protectora de plástico de la superficie a lo largo del borde. Después de despegarla, el producto quedará liso y limpio.

20

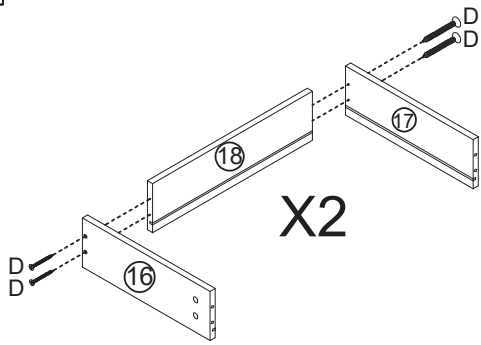

X2

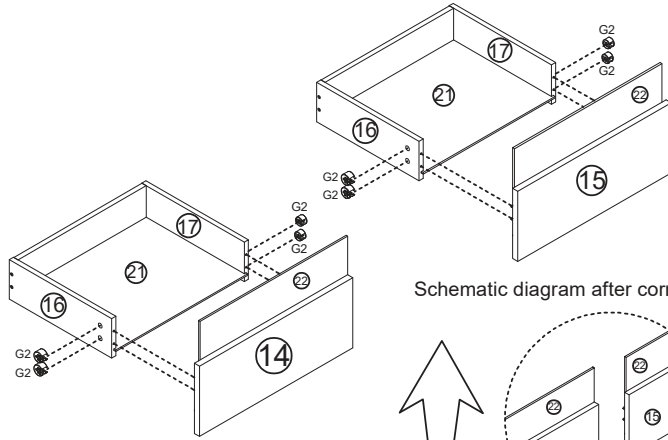

Schematic diagram after correct installation

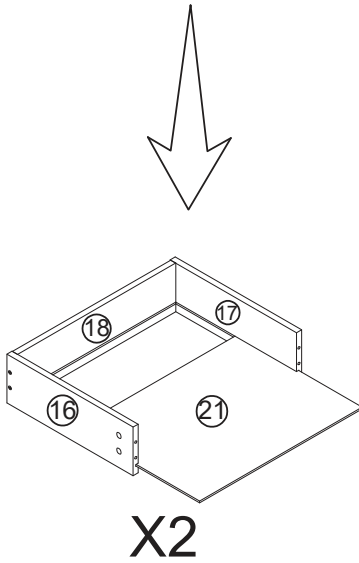
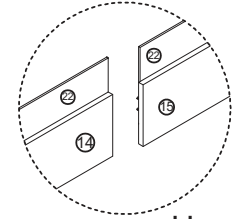

X2

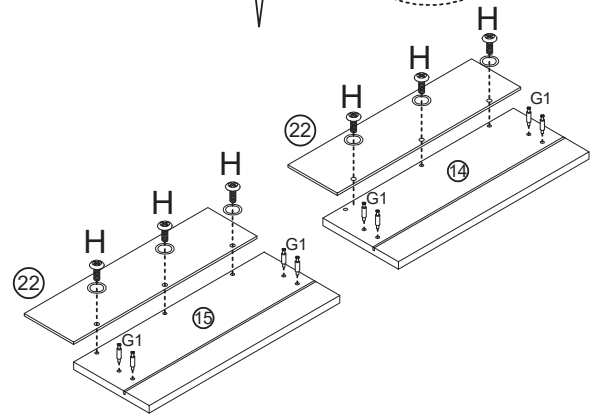

D	Ø3, 5x30
	8PCS
G	
	8PCS
H	
	6PCS

21

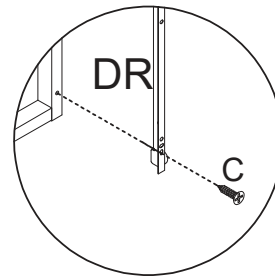
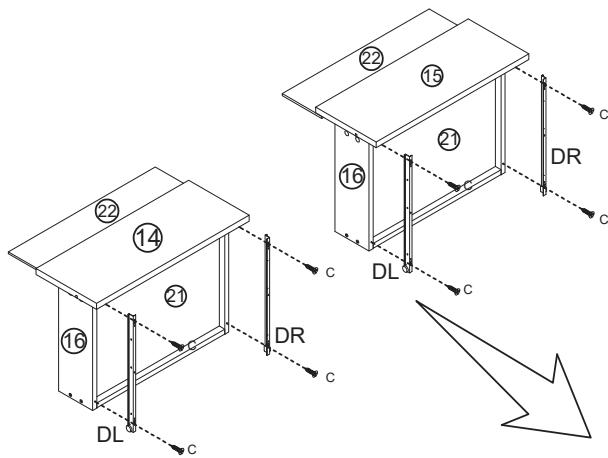

C	Ø3, 5x12
	8PCS
I	
	2PCS

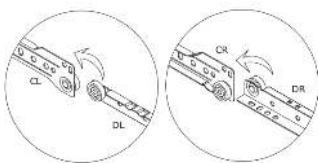
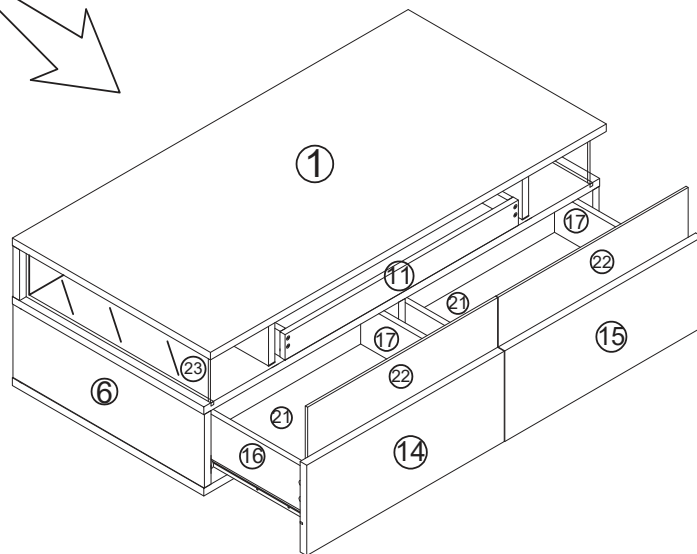

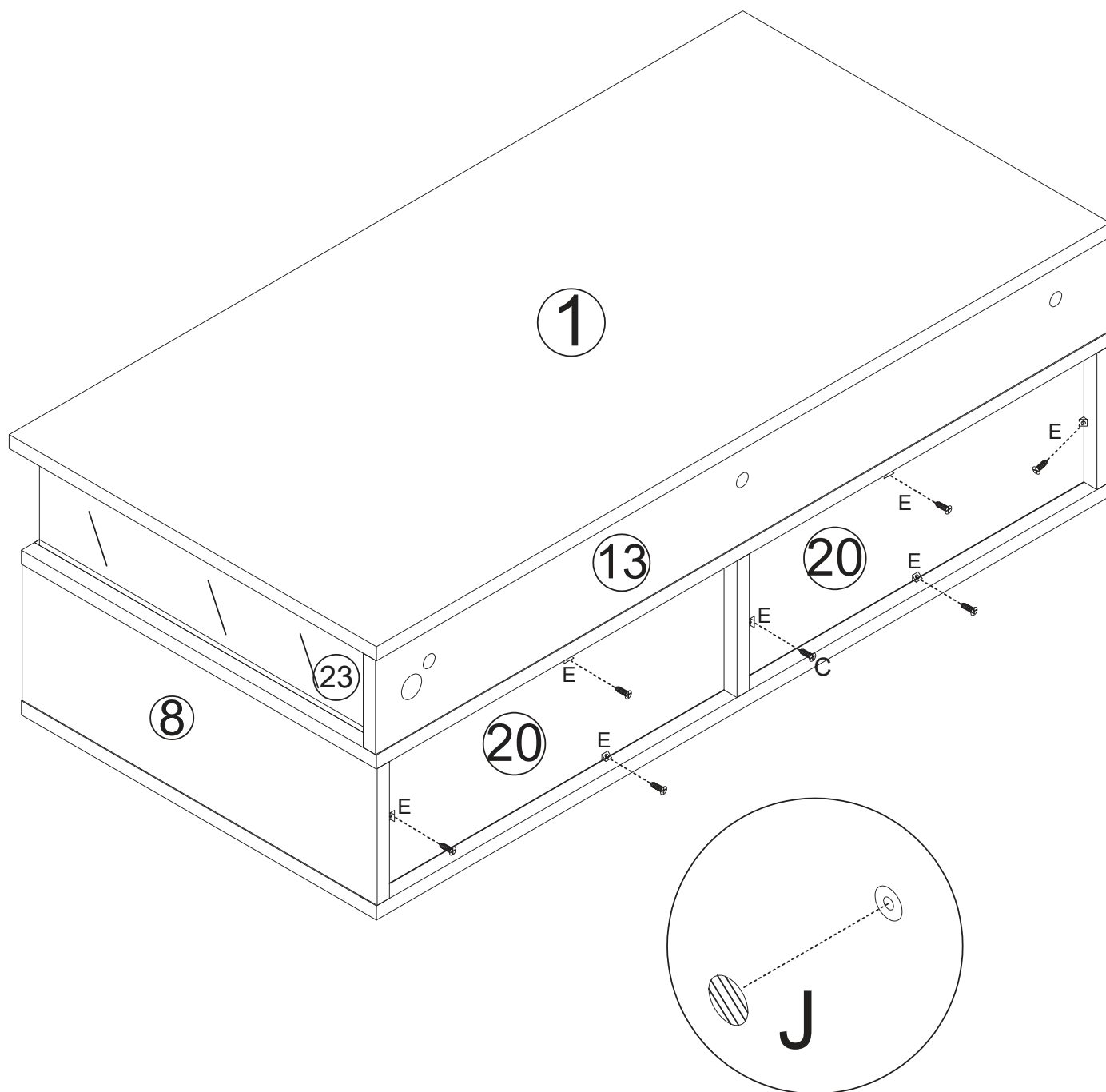

UK: After installing the product, stick the number J on the perforated position.

FR: Une fois le produit installé, collez le numéro J à l'endroit où il ya des trous.

DE: Nach der Installation des Produkts kleben Sie die Nummer J auf die perforierte Position.

IT: Dopo l'installazione del prodotto, fissare il numero J sulla posizione perforata.

ES: Después de instalar el producto, pegue el número J en la posición perforada.

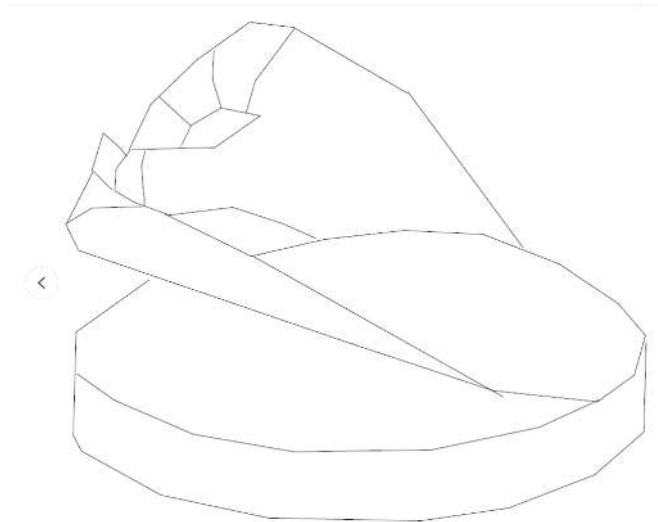

[DE]

BITTE BEACHTEN: Teilenummer 1 14 15

ist mit einer dichten Kunststoffschutzfolie überzogen. Wenn das Produkt nach der Demontage Kratzer aufweist, machen Sie sich bitte keine Sorgen, es handelt sich nicht um einen Produktschaden. Bitte ziehen Sie die schützende Kunststoffolie langsam entlang der Kante von der Oberfläche ab. Nach dem Abziehen wird das Produkt glatt und sauber.

[EN]

PLEASE NOTE: Part number 1 14 15 are covered with a tight plastic protective film. If there are scratches on the product after disassembly, please don't worry, it's not product damage. Please slowly tear off the protective plastic film on the surface along the edge. After peeling off, the product becomes smooth and clean.

[FR]

REMARQUE : les pièces numéro 1 14 15 sont recouvertes d'un film protecteur en plastique étanche. Si le produit présente des rayures après le démontage, ne vous inquiétez pas, il ne s'agit pas d'un dommage au produit. Retirez lentement le film protecteur en plastique sur la surface le long du bord. Une fois décollé, le produit devient lisse et propre.

[IT]

NOTA BENE: il numero di parte 1 14 15

è coperto da una pellicola protettiva in plastica stretta. Se ci sono graffi sul prodotto dopo lo smontaggio, non preoccuparti, non è un danno al prodotto. Strappare lentamente la pellicola protettiva in plastica sulla superficie lungo il bordo. Dopo averla staccata, il prodotto diventa liscio e pulito.

[ES]

NOTA: La pieza número 1 14 15 está cubierta con una película protectora de plástico. Si hay rayones en el producto después de desmontarlo, no se preocupe, no se trata de daños en el producto. Retire lentamente la película protectora de plástico de la superficie a lo largo del borde. Después de despegarla, el producto quedará liso y limpio.

[DE]

HINWEIS: Der Akku in der Fernbedienung erfordert, dass Sie Sie selbst kaufen und installieren.

Modell: CR2025 3.V

[EN]

NOTE: The battery in the remote control requires you to purchase and install it yourself.

Model: CR2025 3.V

[FR]

REMARQUE : La pile de la télécommande est requise, que vous les achetez et les installez vous-même.

Modèle : CR2025 3.V

[IT]

NOTA: la batteria del telecomando richiede, che li acquisti e li installi tu stesso.

Modello: CR2025 3.V

[ES]

NOTA: La batería del control remoto requiere, que los compre e instale usted mismo.

Modelo: CR2025 3.V

1



2



3



4



5



6



Modell : CR2025 3.V

7



8



LED2022-24KEY

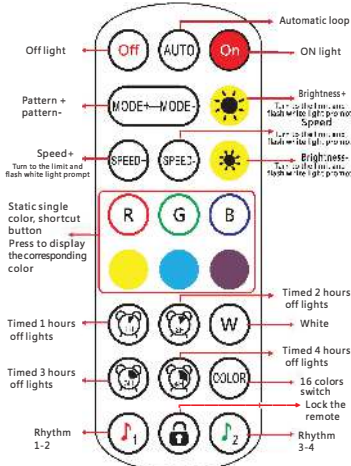

Rhythm 1-2: Single click to switch to 1-2 rhythm mode
 Rhythm 3-4: Click to cycle through the 3-4 rhythm mode
 Remote control lock: After pressing, the remote control is locked, pressing the switch is available, other keys are invalid. After pressing once, the unlock button can be used. After the remote control is locked, press the switch to unlock the remote control.

1

APP Manual

1. Software Overview

1.1 Overview

This is a mobile APP to control LED strip by both IOS and Android phones. The traditional control ways like infrared, 433MHz, 2.4GHz and others old wired ways will be replaced by mobile phone control way with convenient, powerful and suitable features.

Through this mobile APP, you can not only control the color, brightness and color temperature of the LED strips but also set up all kinds of fancy flash mode; Also this APP can change the light of the LED strip according to the rhythm of the music. This APP can set and control several LED strips through Bluetooth and the operation is very simple, easy to learn and easy to use.

1.2 Features

- Adjust color LED strips with 60,000 colors to change color and brightness and adjust monochrome LED strips to change brightness and color temperature
- Play music or turn on a sound playback device, you can let the light change the color and brightness with the rhythm of music, the music rhythm beautiful
- Inside multiple setting mode for color change and control LED strips without mobile
- Long distance control with omni-directional antenna, and many-to-many group control mode
- Once the connection is successful, connect automatically next time

1.3 Performance

APP is easy for use as well as great compatible with all kinds of smart phones; After the actual test of hundreds of mobile phones verification, the compatibility is above 95% of mobile phones in the market. APP is small and convenient, it consumes less system resources, so the requirements of the mobile configuration are low. Control delay is small, the operation feels good, light control is smooth with people's visual sense.

2. Operating Environment

This APP program requires phones of system above Android 4.3 and IOS 8.0. Mobile phone configuration is not limited.

3. Instructions

Note: Android version and IOS version download and use the same method, here in the Android version as an example.

3.1 APP Download

2

3.2 App Operation

(1) Click on the LotusLantern APP icon, enter the APP page:



(2) After entering the APP interface, if Bluetooth is not enabled, "an application wants to enable the Bluetooth function of this device." Click (Allow)



3

(4) Click to enter the app list and lamp list



(5) Click to RGB manual adjustment view: (6) switch to the mode interface:

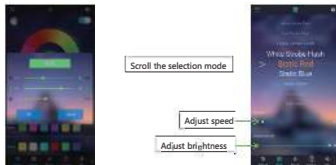

4

(7) switch to the music rhythm interface:



(8) Switch to the online music interface:



(9) Switch to the microphone rhythm interface:



5

Music rhythm through the microphone on the product



(10) Switch to the schedule interface:



(11) Switch to the manually assign color interface:

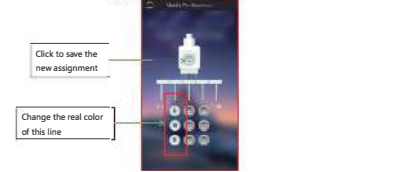

6