

**INSTRUCTIONS D'ASSEMBLAGE
ASSEMBLY INSTRUCTIONS**

**BUREAU - 48"L / NOYER / METAL ARGENT
COMPUTER DESK - 48"L / WALNUT / SILVER METAL**



**POUR DE L'ASSISTANCE OU POUR COMMANDER
DES PIÈCES CONTACTEZ NOTRE DÉPARTEMENT
DE SERVICE À LA CLIENTÈLE.**

**FOR ASSISTANCE OR TO ORDER PARTS
CONTACT OUR CUSTOMER SERVICE DEPARTMENT**



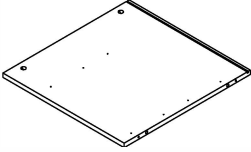
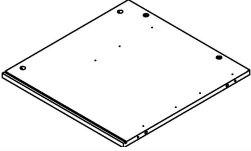
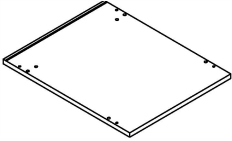
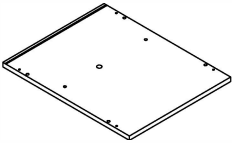
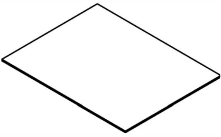
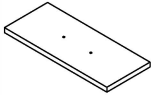
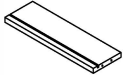
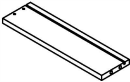
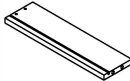
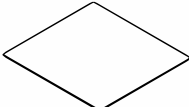



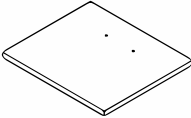
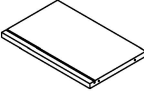
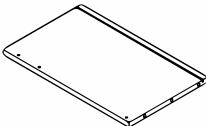
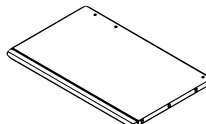
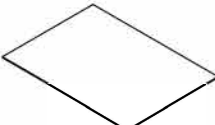
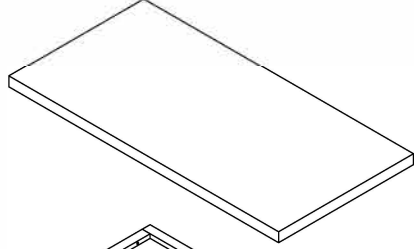
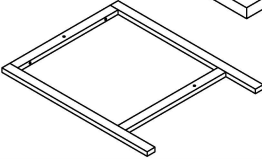
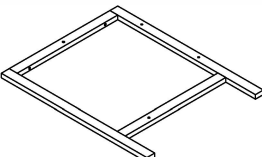
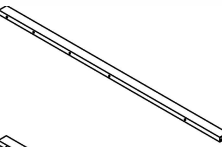
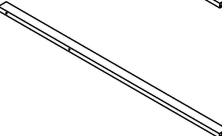



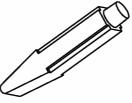

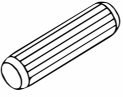
IDENTIFICATION DES PIÈCES PARTS IDENTIFICATION

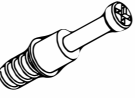
1		PANNEAU CÔTÉ GAUCHE LEFT SIDE PANEL	1MC 1PC
2		PANNEAU CÔTÉ DROIT RIGHT SIDE PANEL	1MC 1PC
3		PANNEAU DU BAS BOTTOM PANEL	1MC 1PC
4		PANNEAU DU DESSUS TOP PANEL	1MC 1PC
5		PANNEAU ARRIÈRE BACK PANEL	1MC 1PC
6		PANNEAU DEVANT DU TIROIR DRAWER FRONT PANEL	1MC 1PC
7		PANNEAU ARRIÈRE DU TIROIR DRAWER BACK PANEL	1MC 1PC
8		PANNEAU CÔTÉ GAUCHE DU TIROIR LEFT DRAWER SIDE PANEL	1MC 1PC
9		PANNEAU CÔTÉ DROIT DU TIROIR RIGHT DRAWER SIDE PANEL	1MC 1PC
10		PANNEAU DU FOND DU TIROIR DRAWER BOTTOM PANEL	1MC 1PC

IDENTIFICATION DES PIÈCES PARTS IDENTIFICATION

11		PANNEAU DEVANT DU TIROIR DRAWER FRONT PANEL	1MC 1PC
12		PANNEAU ARRIÈRE DU TIROIR DRAWER BACK PANEL	1MC 1PC
13		PANNEAU CÔTÉ GAUCHE DU TIROIR LEFT DRAWER SIDE PANEL	1MC 1PC
14		PANNEAU CÔTÉ DROIT DU TIROIR RIGHT DRAWER SIDE PANEL	1MC 1PC
15		PANNEAU DU FOND DU TIROIR DRAWER BOTTOM PANEL	1MC 1PC
16		DESSUS DE TABLE TABLE TOP	1MC 1PC
17		PATTE (GAUCHE) LEG (LEFT)	1MC 1PC
18		PATTE (DROIT) LEG (RIGHT)	1MC 1PC
19		BARRE TRANSVERSALE CROSSBAR	1MC 1PC
20		BARRE TRANSVERSALE CROSSBAR	1MC 1PC

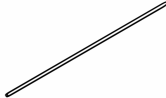
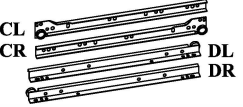
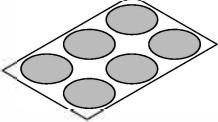
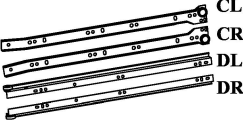
IDENTIFICATION DES PIÈCES DE MONTAGE
HARDWARE IDENTIFICATION

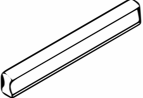
A		COLLE/GLUE(15g)	1MC / PC	K		23mm	4MCX / PCS
B		ø8 x 30mm	14MCX / PCS	L		28mm	6MCX / PCS
C		35mm	8MCX / PCS	M		62mm	8MCX / PCS
D		ø15x12mm	8MCX / PCS	N		63mm	3MCX / PCS
E		35mm	8MCX / PCS	O		ALLEN WRENCH 57x21mm	1MC / PC
F		42mm	4MCX / PCS	P		332mm	2MCX / PCS
G		CL CR DL DR 350mm	1 ENS / SET	Q		ø20mm	2MCX / PCS
H		CL CR DL DR 450mm	1 ENS / SET				
I		12mm	26MCX / PCS				
J		120mm	2MCX / PCS				

ÉTAPE / STEP 1

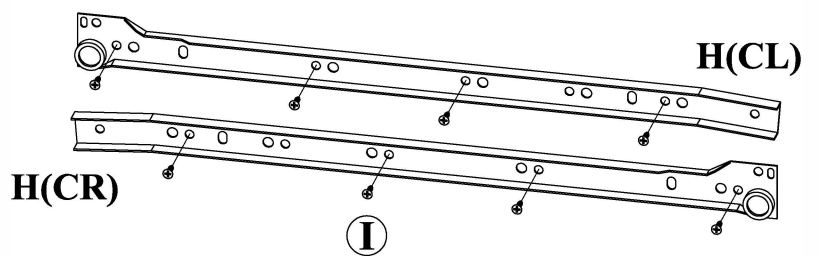
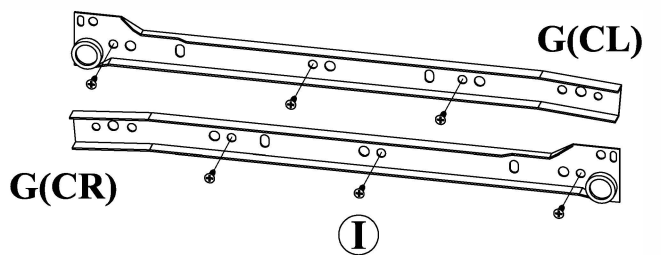
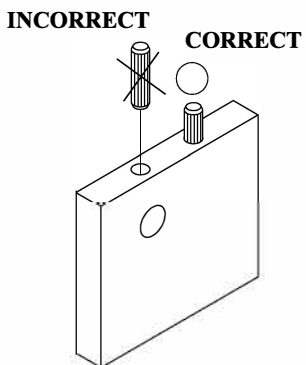
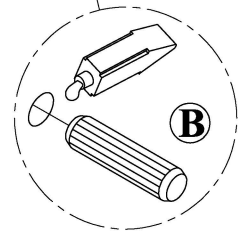
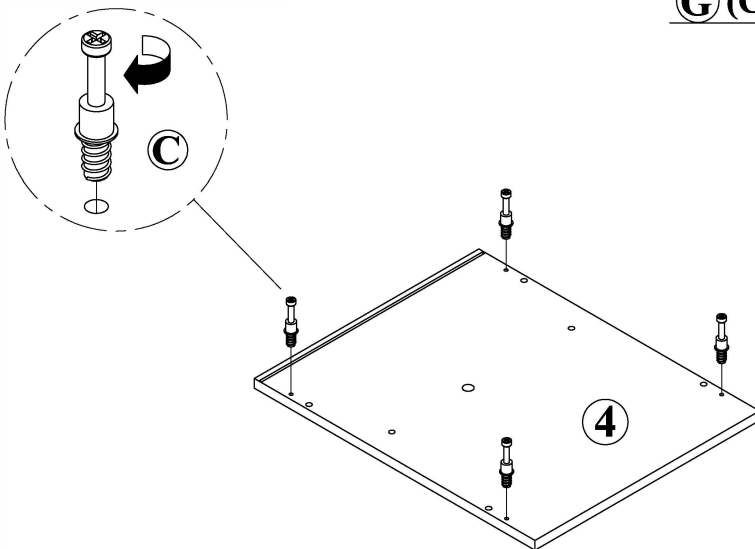
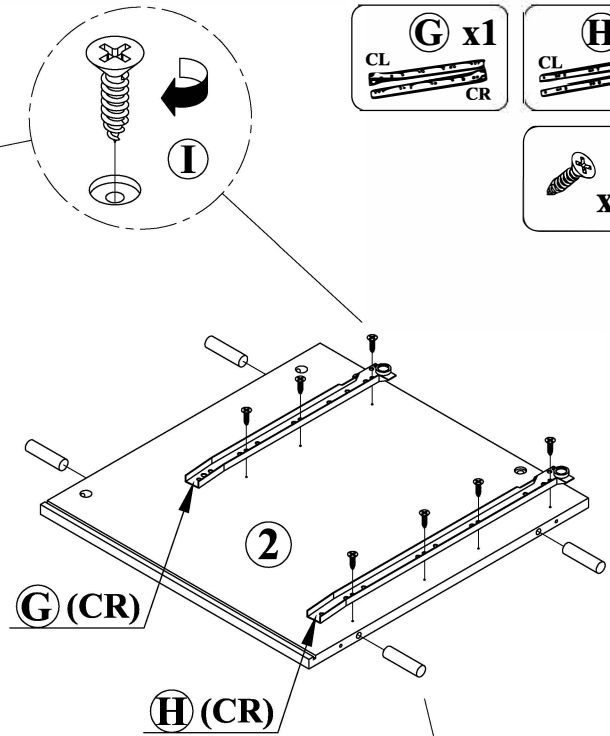
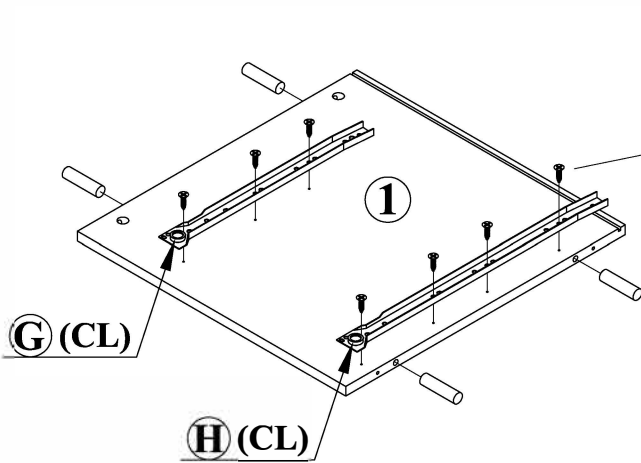
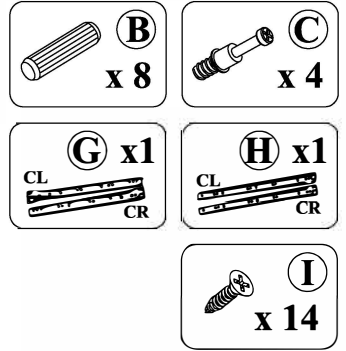

La colle (A) doit être utilisée aux endroits indiqués afin de solidifier l'étagère assemblée.
The Glue (A) should be used in the indicated locations to help solidify the assembled unit.

ÉTAPE / STEP 2

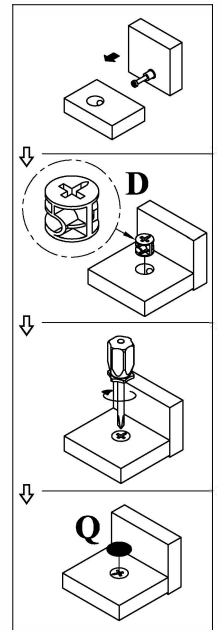
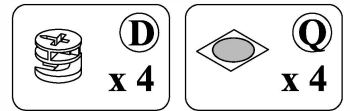
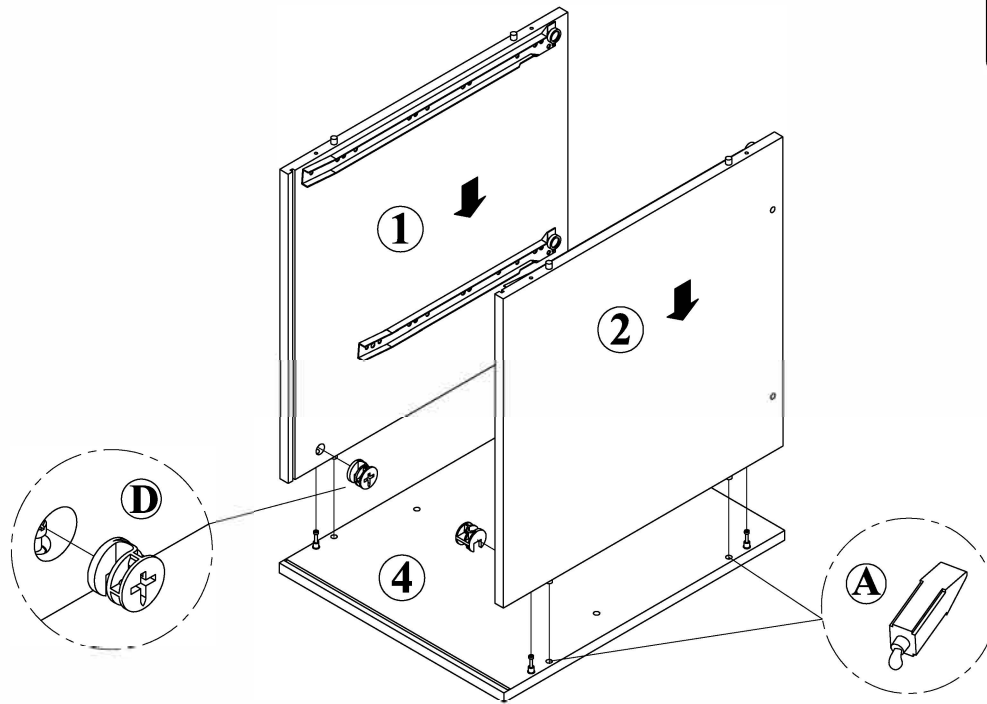

ÉTAPE / STEP 3

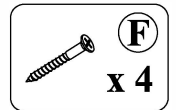
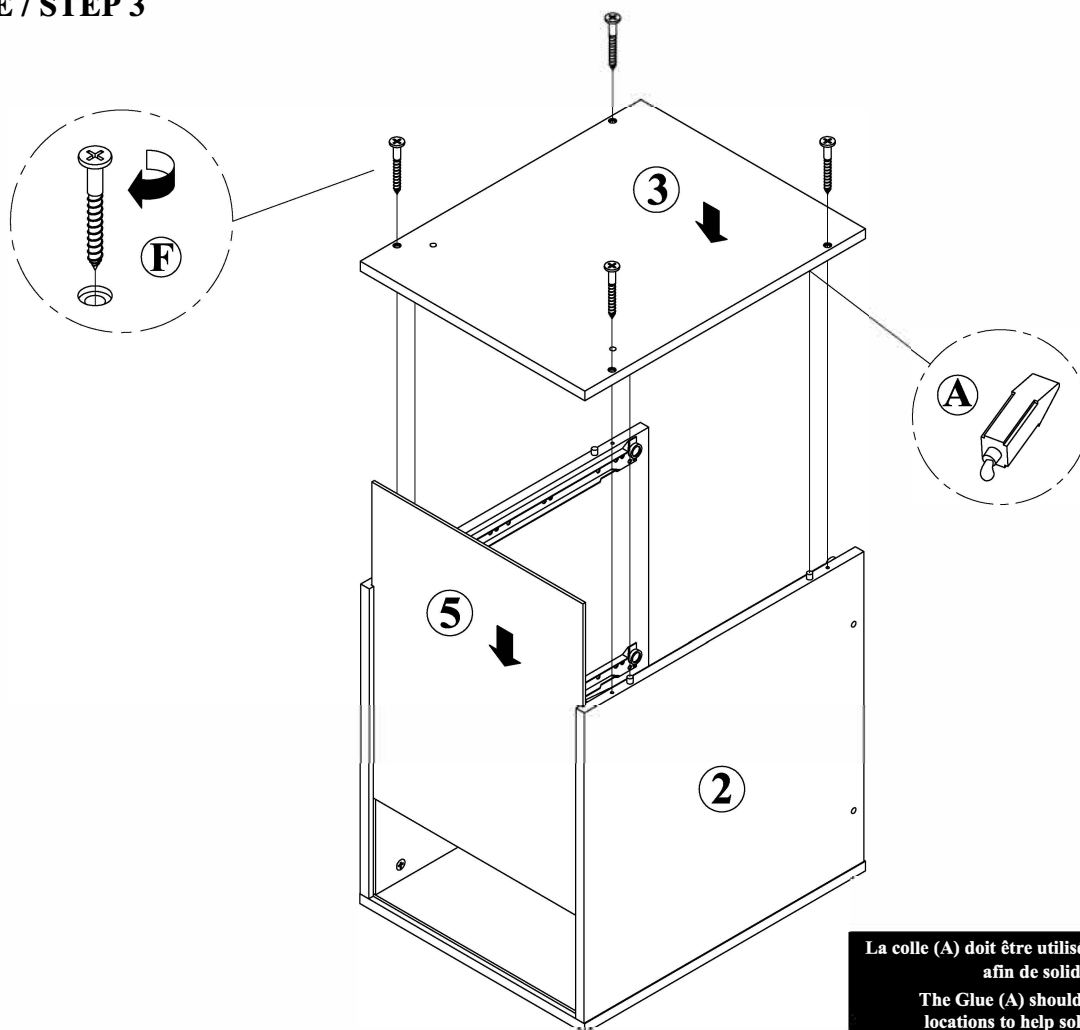

La colle (A) doit être utilisée aux endroits indiqués afin de solidifier l'étagère assemblée.
The Glue (A) should be used in the indicated locations to help solidify the assembled unit.

ÉTAPE / STEP 4

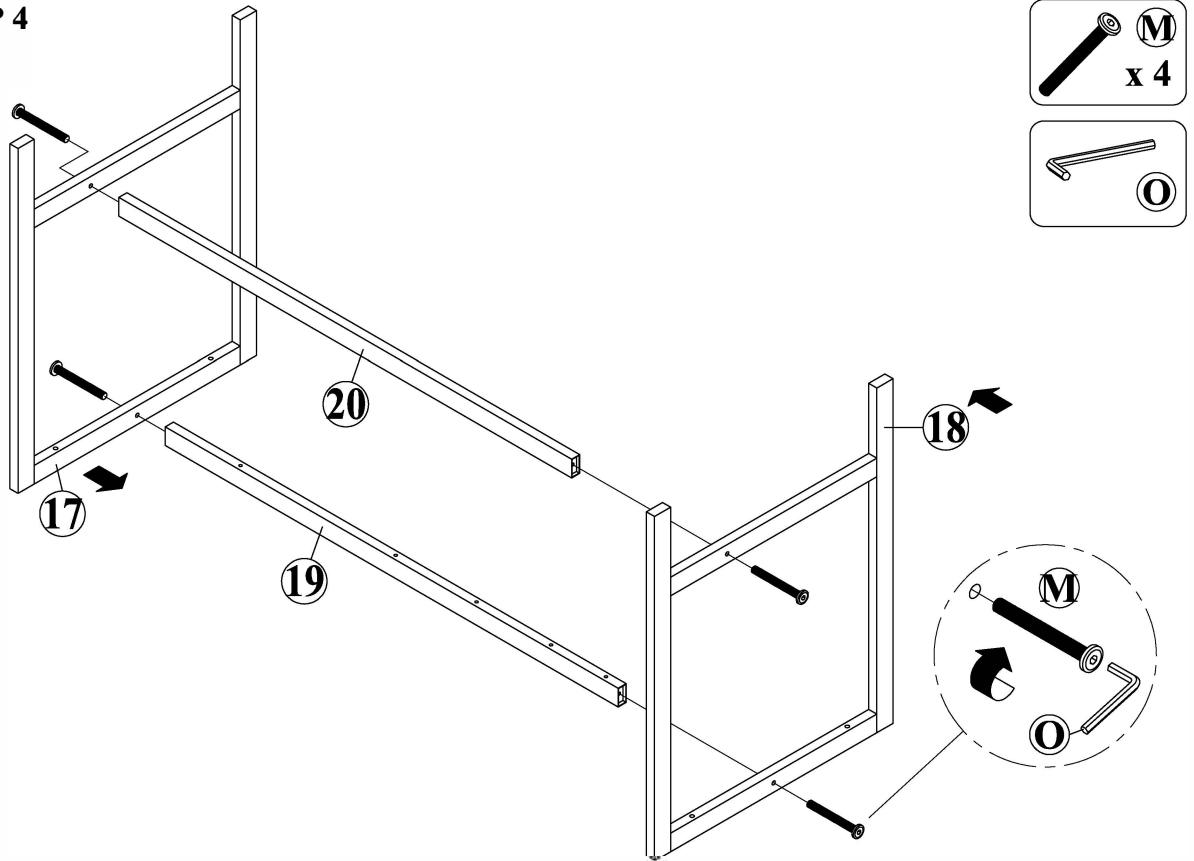

ÉTAPE / STEP 5

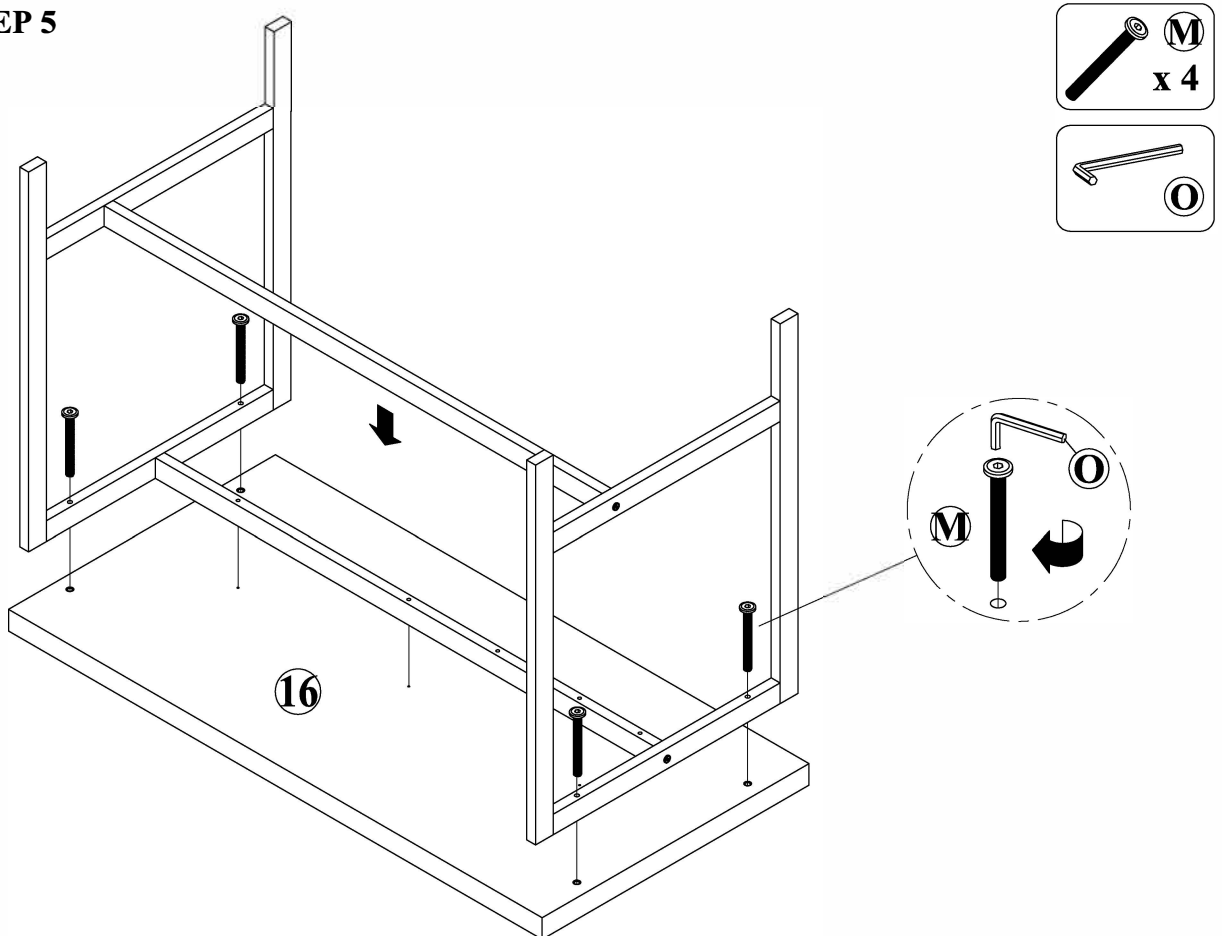

ÉTAPE / STEP 6

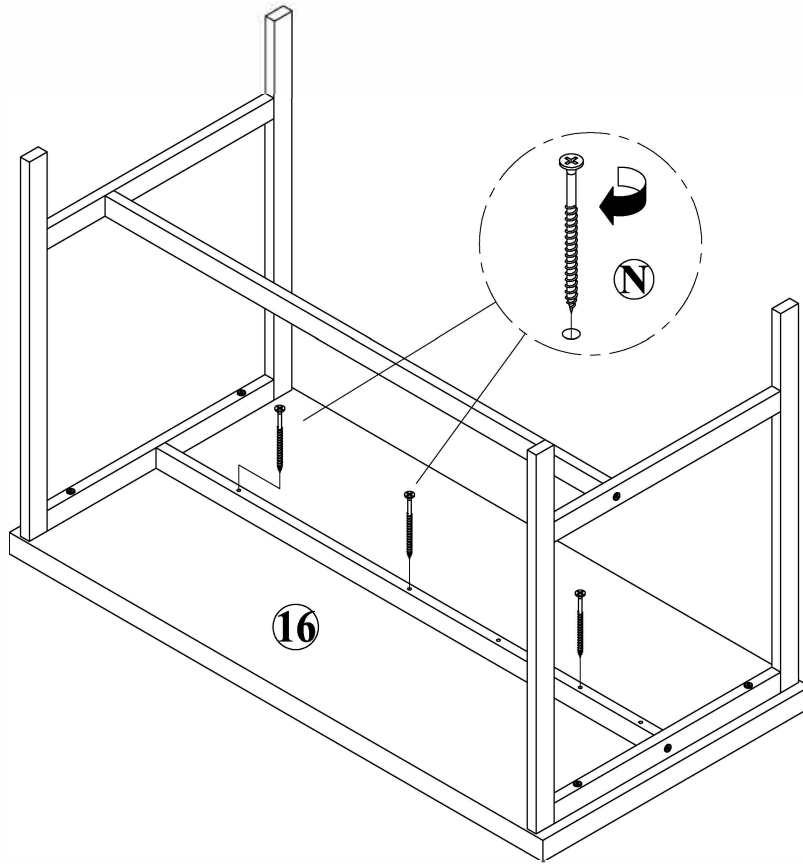
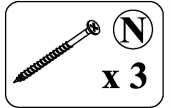

ÉTAPE / STEP 7

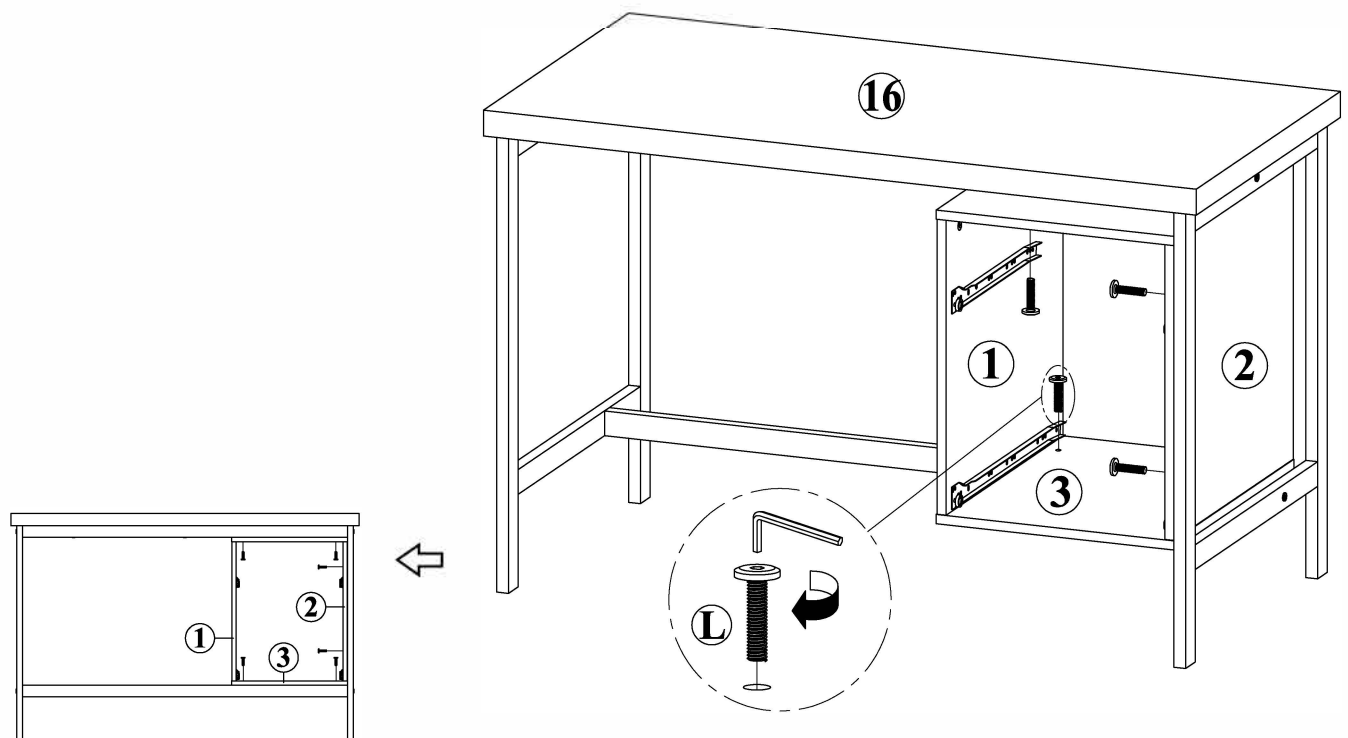
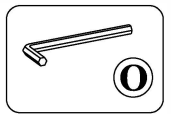
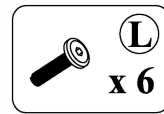

ÉTAPE / STEP 8-1

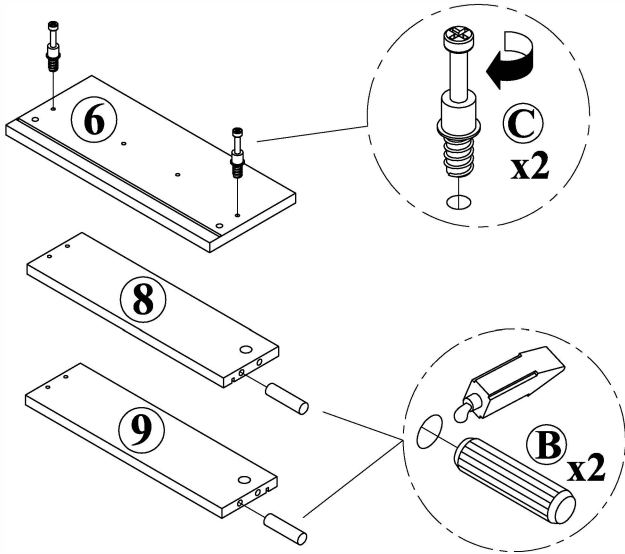

ÉTAPE / STEP 8-2

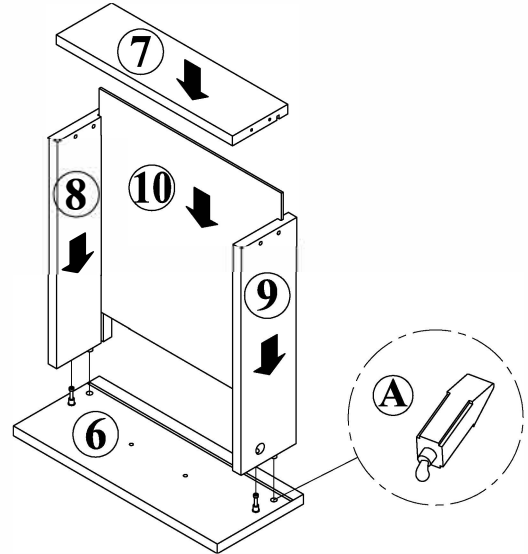

ÉTAPE / STEP 8-3

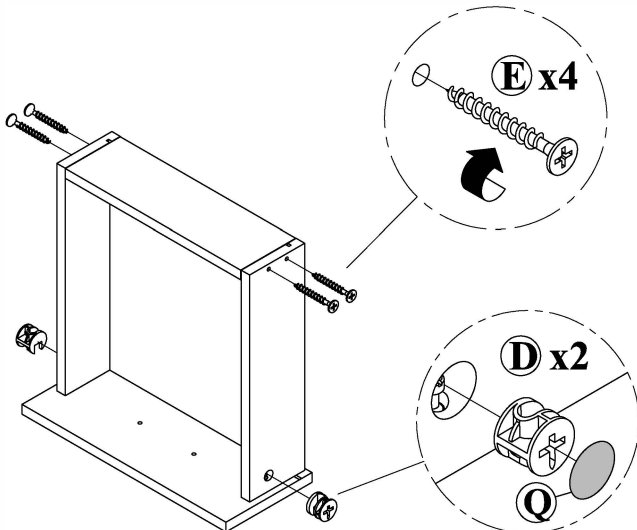

ÉTAPE / STEP 8-4

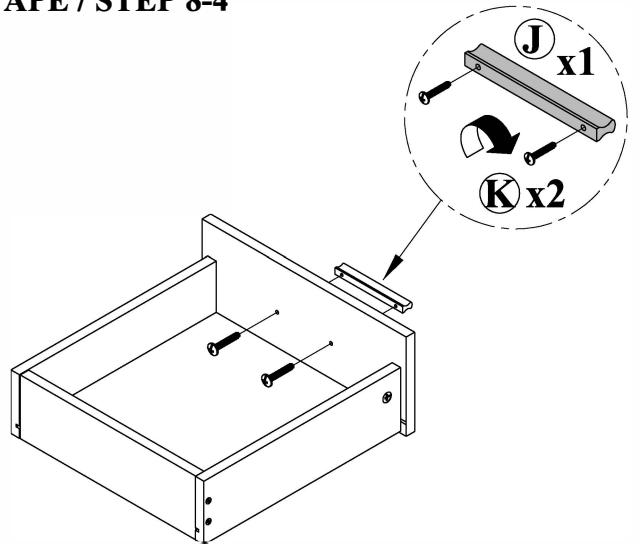

ÉTAPE / STEP 8-5

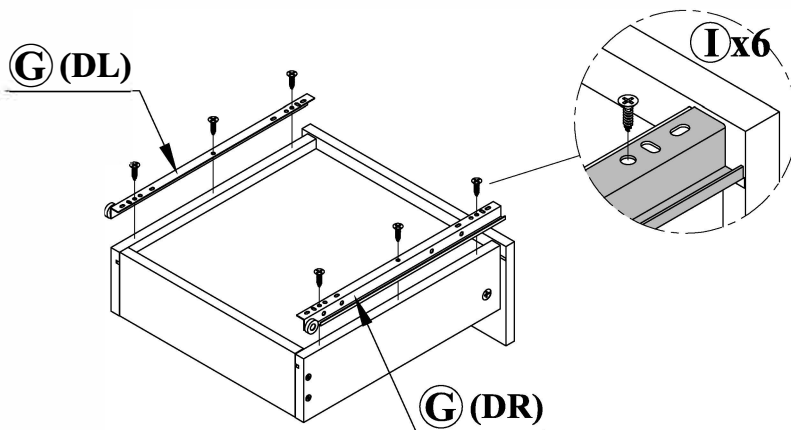

La colle (A) doit être utilisée aux endroits indiqués afin de solidifier l'étagère assemblée.
The Glue (A) should be used in the indicated locations to help solidify the assembled unit.

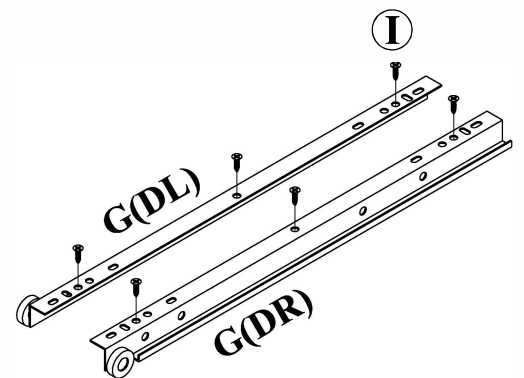

ÉTAPE / STEP 9-1

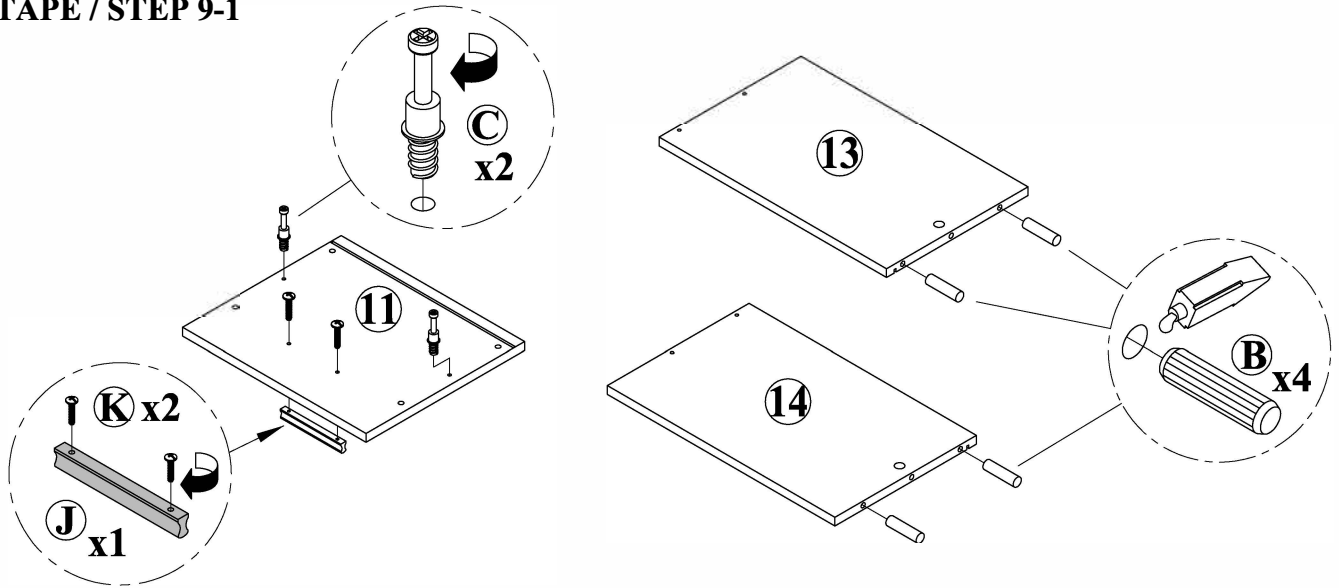

ÉTAPE / STEP 9-2

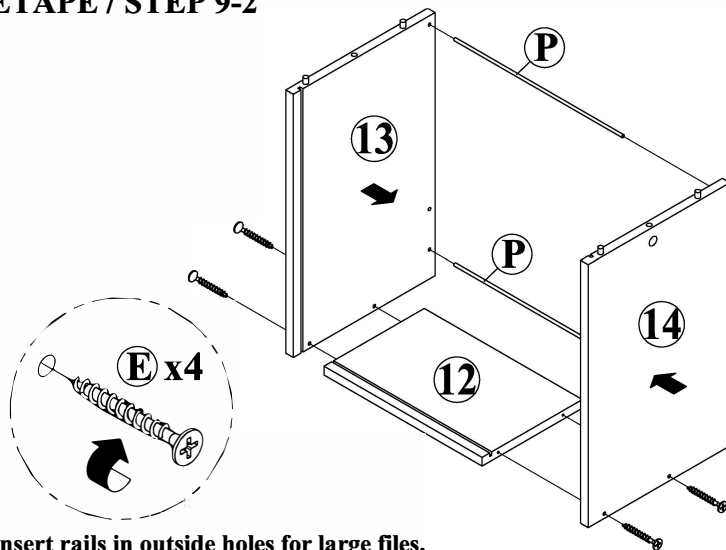

Insert rails in outside holes for large files.
Insert rails in inside holes for small files.

ÉTAPE / STEP 9-3

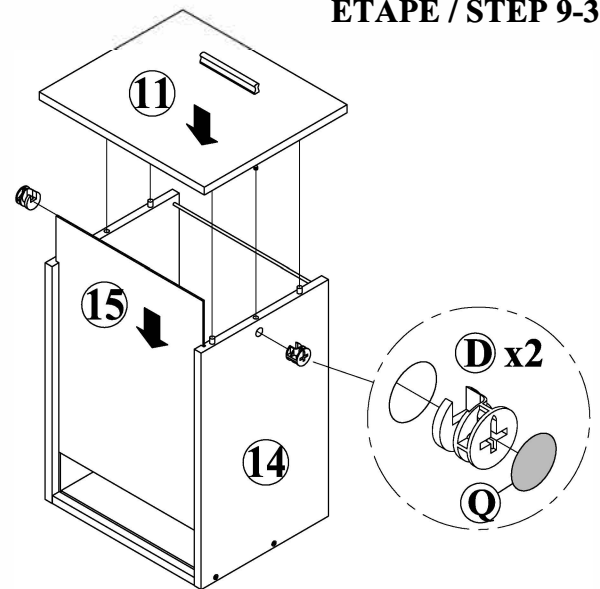

ÉTAPE / STEP 9-4

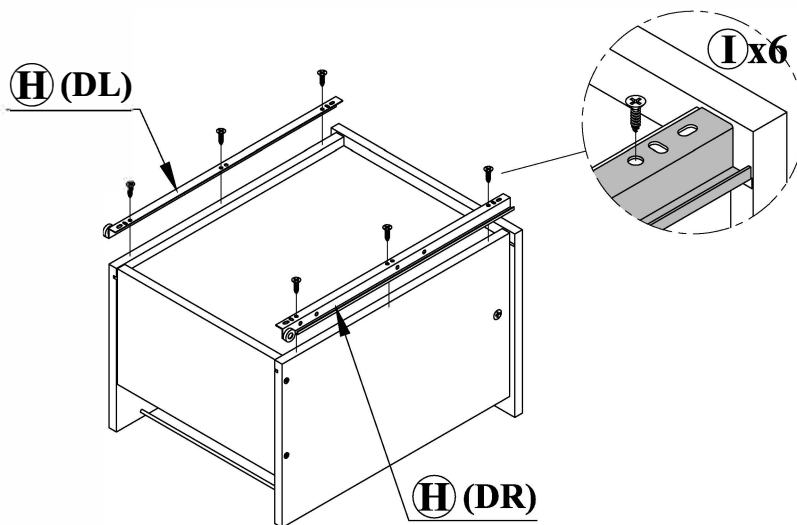

La colle (A) doit être utilisée aux endroits indiqués
afin de solidifier l'étagère assemblée.
The Glue (A) should be used in the indicated
locations to help solidify the assembled unit.

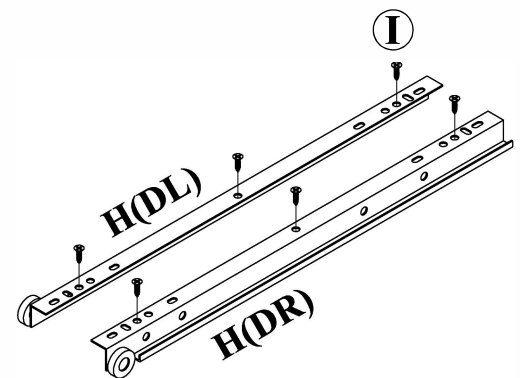

ÉTAPE / STEP 10

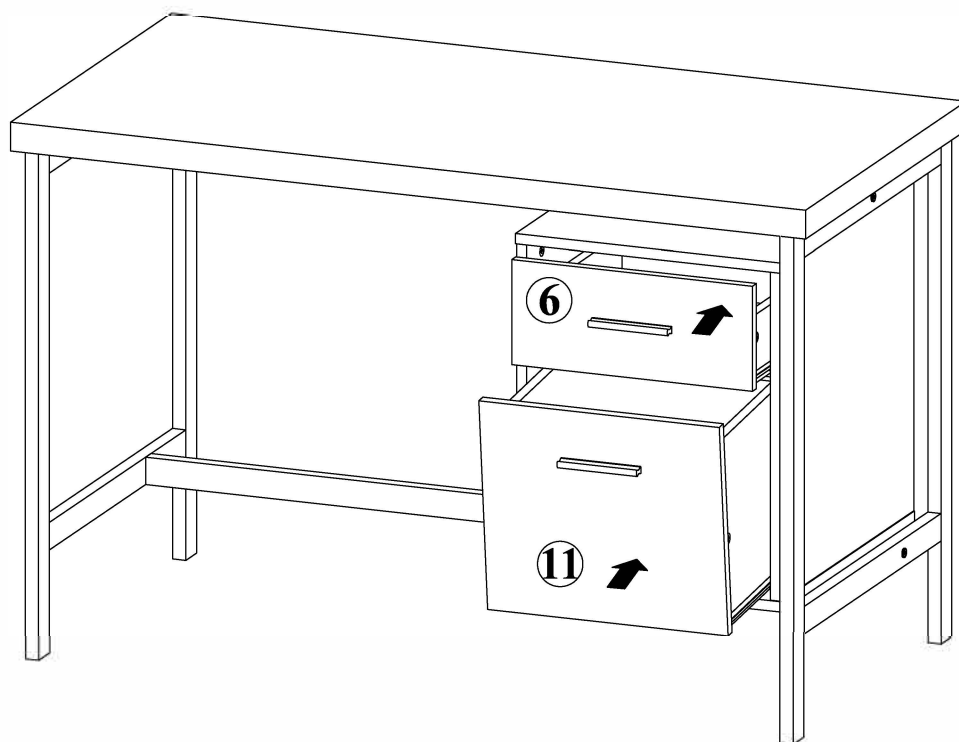

ÉTAPE / STEP 11

