

ASSEMBLY INSTRUCTIONS
COASTER FINE FURNITURE

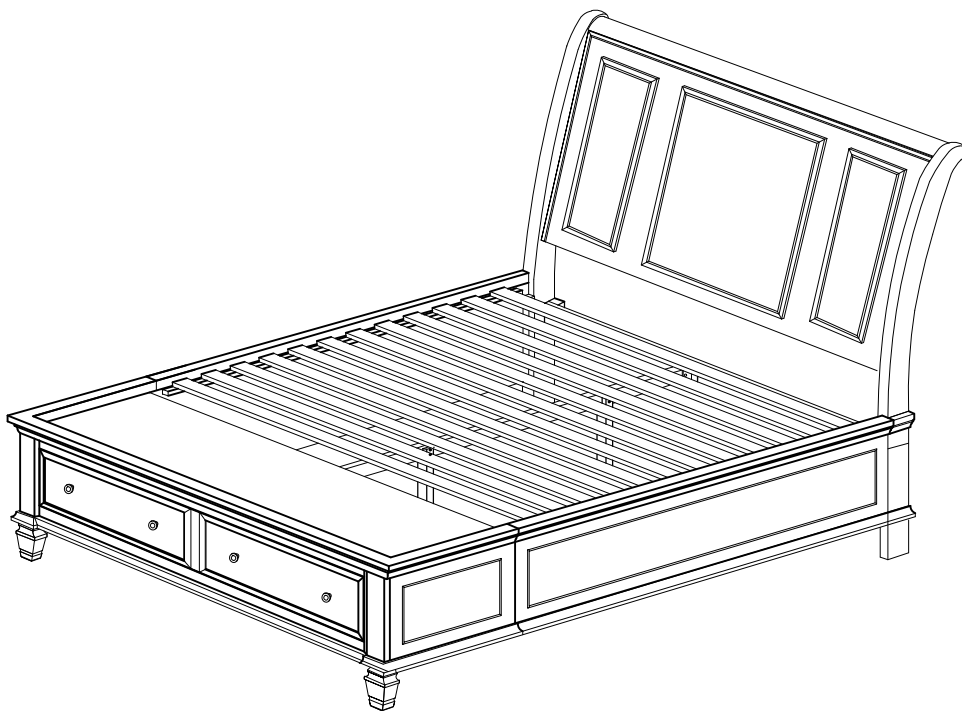

Fine Furniture for every stage of life

201309KE (B1-B3)
Eastern King Storage Bed

REVISION 0 : 06/03/2011
REVISION 1 : 09/27/2011
REVISION 2 : 07/17/2012
REVISION 3 : 08/29/2012
REVISION 4 : 11/28/2012
REVISION 5 : 03/17/2016
REVISION 6 : 08/14/2018
REVISION 7 : 12/04/2019
REVISION 8 : 08/06/2020

ITEM: 201309KE (B1-B3)



ASSEMBLY INSTRUCTIONS

ASSEMBLY TIPS:

1. Remove hardware from box and sort by size.
2. Please check to see that all hardware and parts are present prior to start of assembly.
3. Please follow attached instructions in the same sequence as numbered to assure fast & easy assembly.



WARNING!

1. Don't attempt to repair or modify parts that are broken or defective. Please contact the store immediately.
2. This product is for home use only and not intended for commercial establishments.

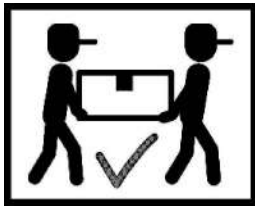





ASSEMBLY TIME





35 MINUTES

PARTS IDENTIFICATION

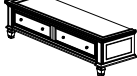

B1 (BOX 1)

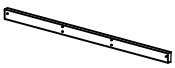
A	HEADBOARD PANEL		1PC
B1	LEFT HEADBOARD LEG		1PC
B2	RIGHT HEADBOARD LEG		1PC
H	HEADBOARD BOTTOM RAIL		1PC

B2 (BOX 2)

C	STORAGE FOOTBOARD		1PC
E	CENTER RAIL SUPPORT WITH LEVELER		2PCS
F	CENTER RAIL		1PC
G	ROLL SLAT (12PCS)		1SET

B3 (BOX 3)

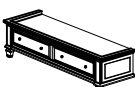
D1	LEFT BED RAIL		1PC
D2	RIGHT BED RAIL		1PC
HB	201309KE (B1) FROM BOX 1 HEADBOARD COMPLETE		1PC
C	201309KE (B2) FROM BOX 2 STORAGE FOOTBOARD		1PC

ITEM: 201309KE (B1-B3)



ASSEMBLY INSTRUCTIONS

ASSEMBLY TIPS:

1. Remove hardware from box and sort by size.
2. Please check to see that all hardware and parts are present prior to start of assembly.
3. Please follow attached instructions in the same sequence as numbered to assure fast & easy assembly.







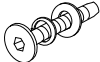

WARNING!

1. Don't attempt to repair or modify parts that are broken or defective. Please contact the store immediately.
2. This product is for home use only and not intended for commercial establishments.

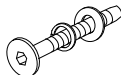
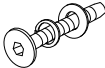
HARDWARE IDENTIFICATION

Z-B1 (BOX 1) - HARDWARE PACK IS LOCATED IN 201309KE (B1)

1	ALLEN WRENCH (M4 x 110mm - BLK)		1PC
2	SHORT BOLT (M6 x 35mm - BLK)		8PCS
3	WOOD DOWEL (M8 x 30mm)		12PCS
4	LONG FLAT HEAD SCREW (#8 x 1 1/8" - BLK)		24PCS
5	LONG BOLT (M6 x 60mm - BLK)		10PCS
6	MEDIUM BOLT (M6 x 45mm - BLK)		6PCS
7	SHORT FLAT HEAD SCREW (M4 x 20mm - BLK)		8PCS
8	WRENCH (2 x 24.5 x 85 - RBW)		1PC
9	HEX NUT (M6 - RBW)		2PCS
10	U BRACKET (26 x 63 x 70mm - RBW)		2PCS

NOTE:

Phillips head screw driver is required in the assembly process; however, manufacturer does not provide this item.

ITEM: 201309KE (B1-B3)



ASSEMBLY INSTRUCTIONS

STEP 1

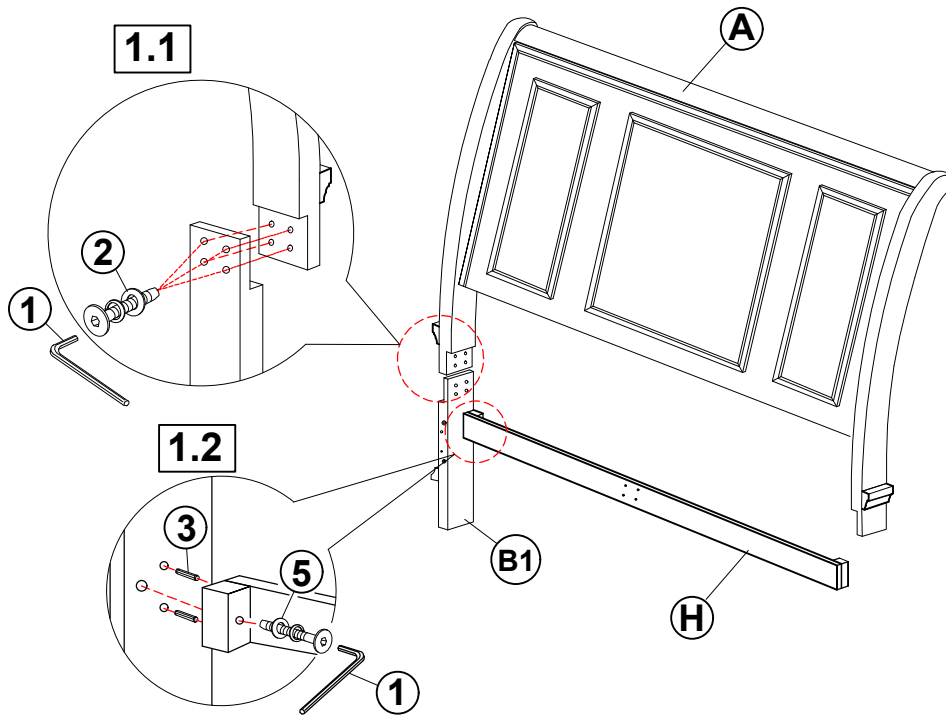

STEP 2

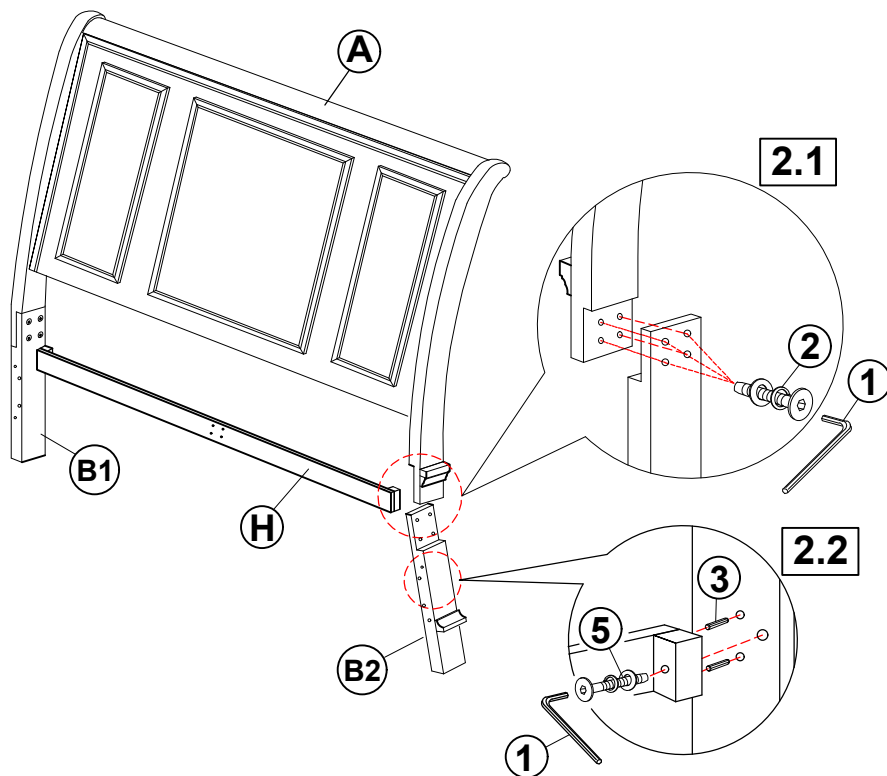

ITEM: 201309KE (B1-B3)



ASSEMBLY INSTRUCTIONS
STEP 3

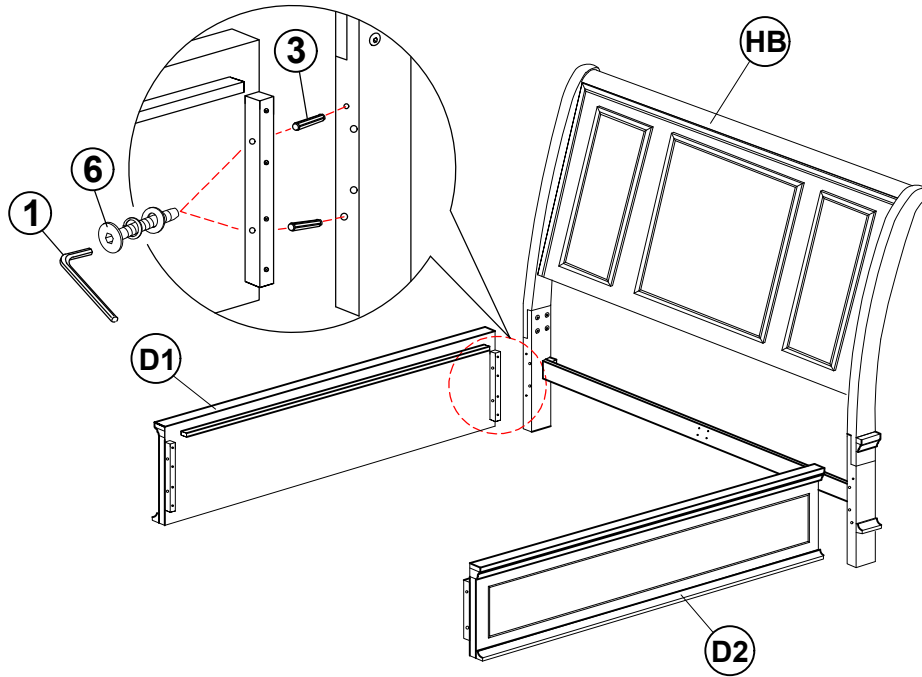

STEP 4

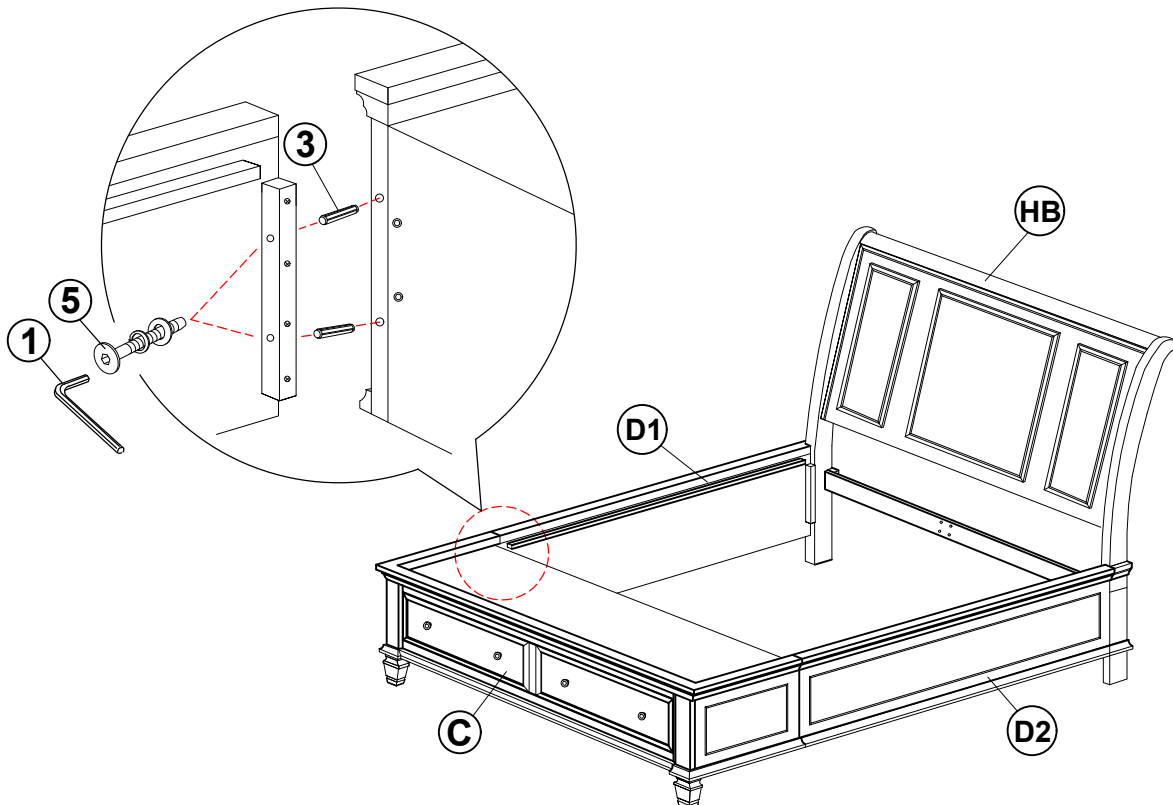

ITEM: 201309KE (B1-B3)



ASSEMBLY INSTRUCTIONS
STEP 5

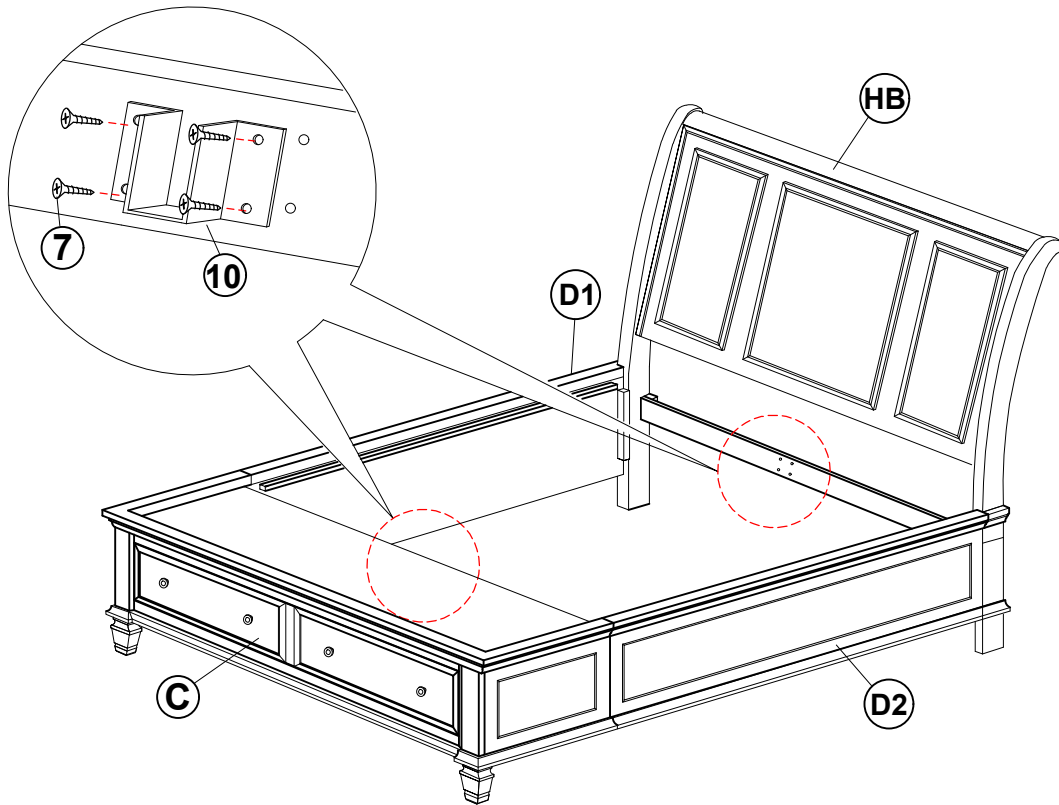

STEP 6

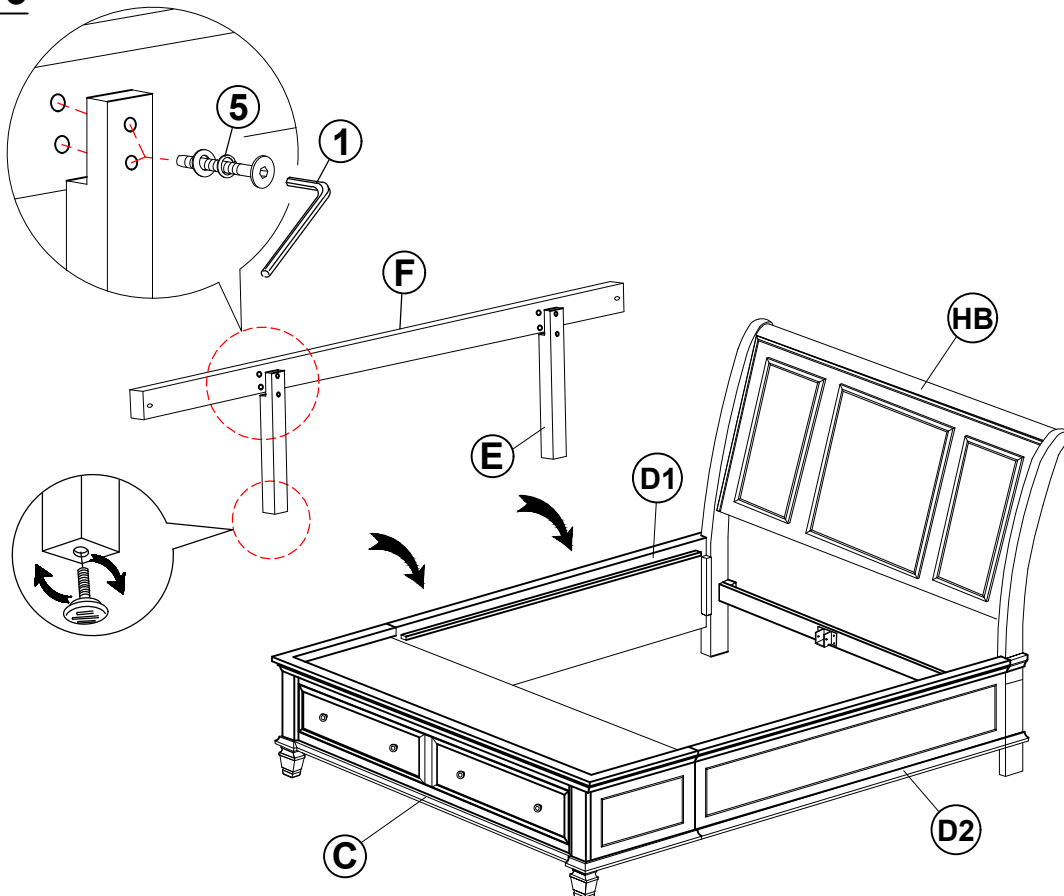

ITEM: **201309KE (B1-B3)**



ASSEMBLY INSTRUCTIONS
STEP 7

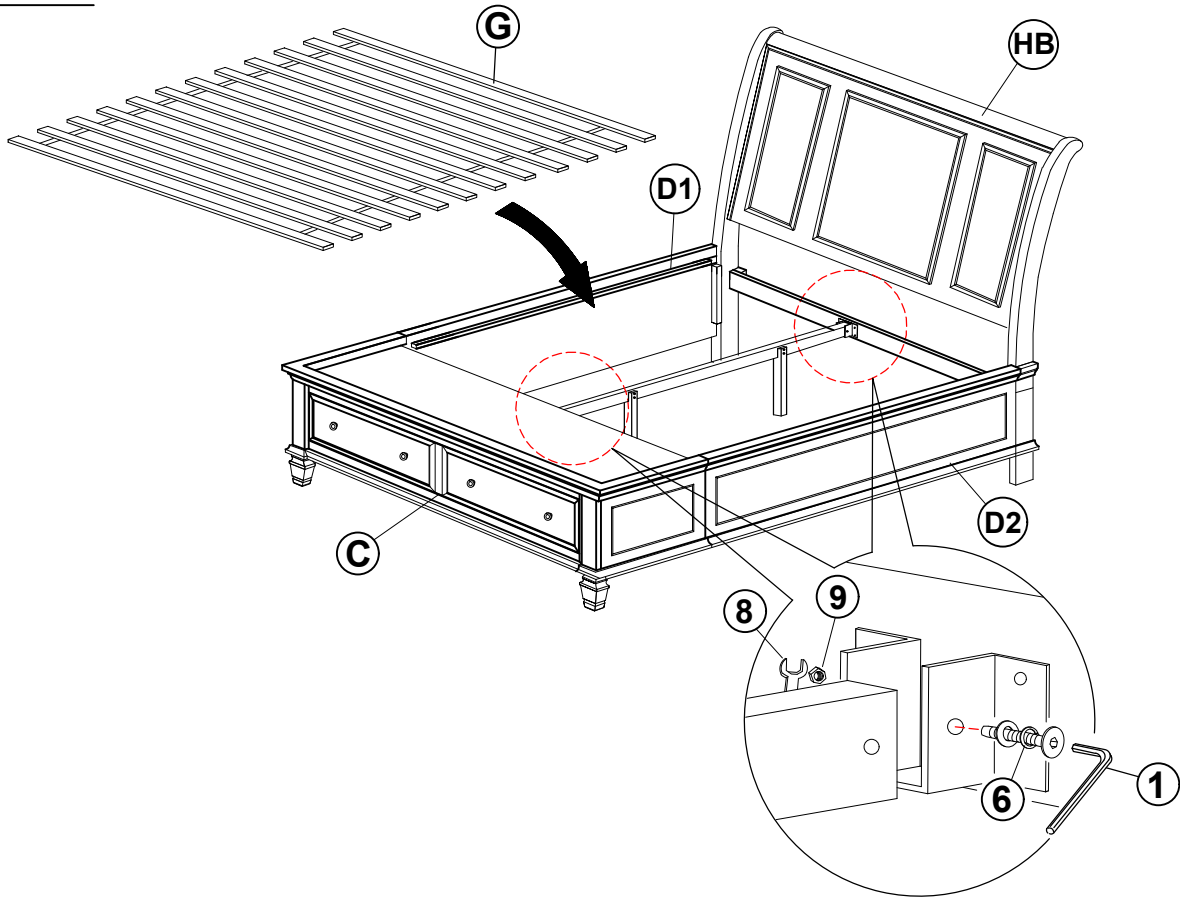

STEP 8

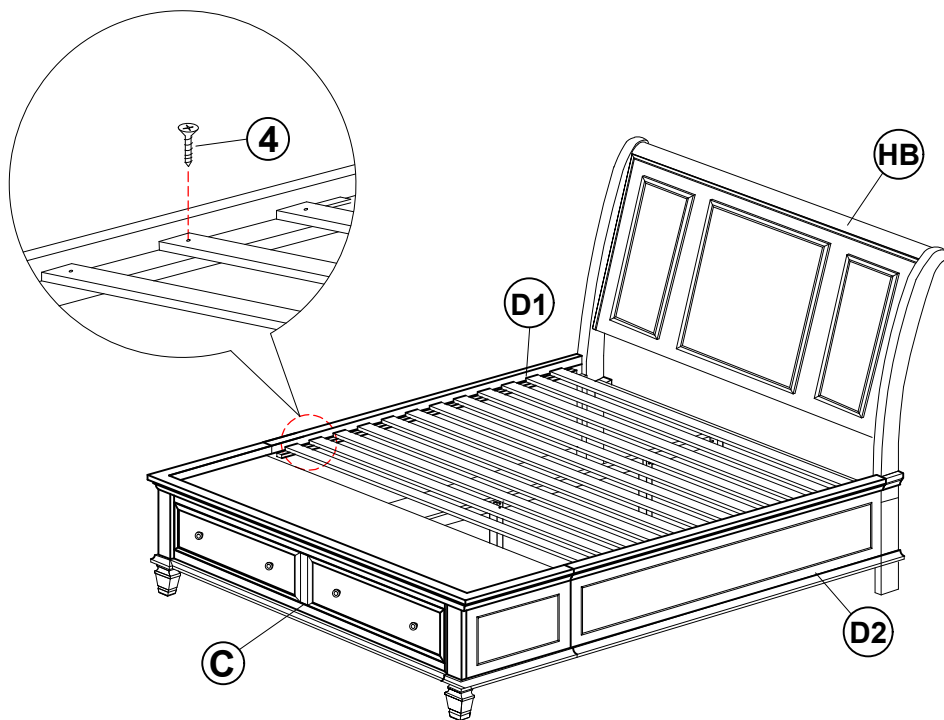

ITEM: **201309KE (B1-B3)**



ASSEMBLY INSTRUCTIONS

STEP 9

COMPLETE

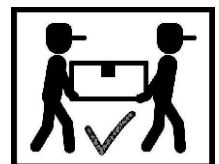
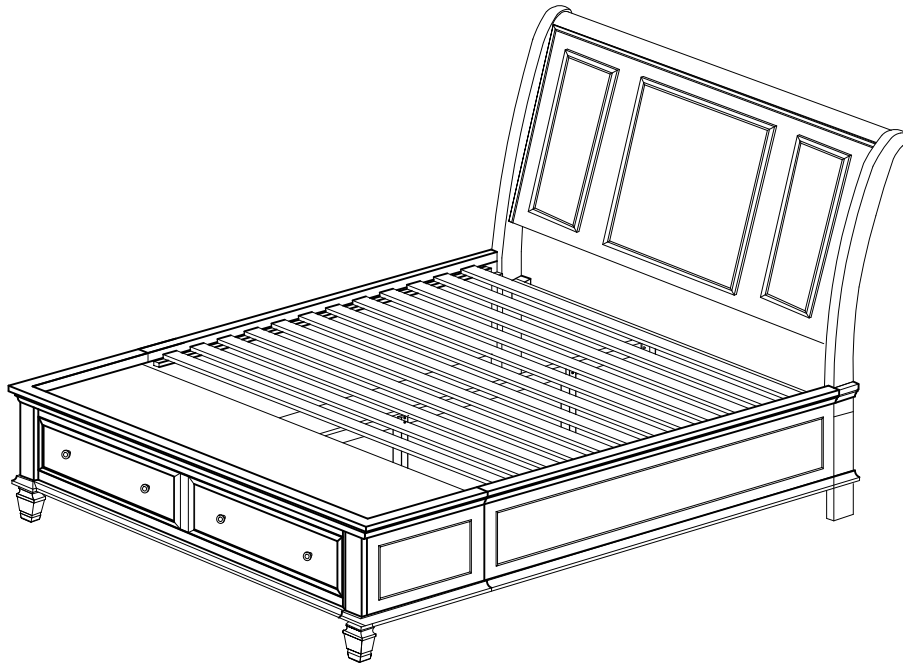

ITEM: **201309KE (B1-B3)**



Inner Size : 76.00"W X 81.00"D

Inner Size of Drawer : 33.00"W X 14.75"D X 5.50"H X 0.25"T

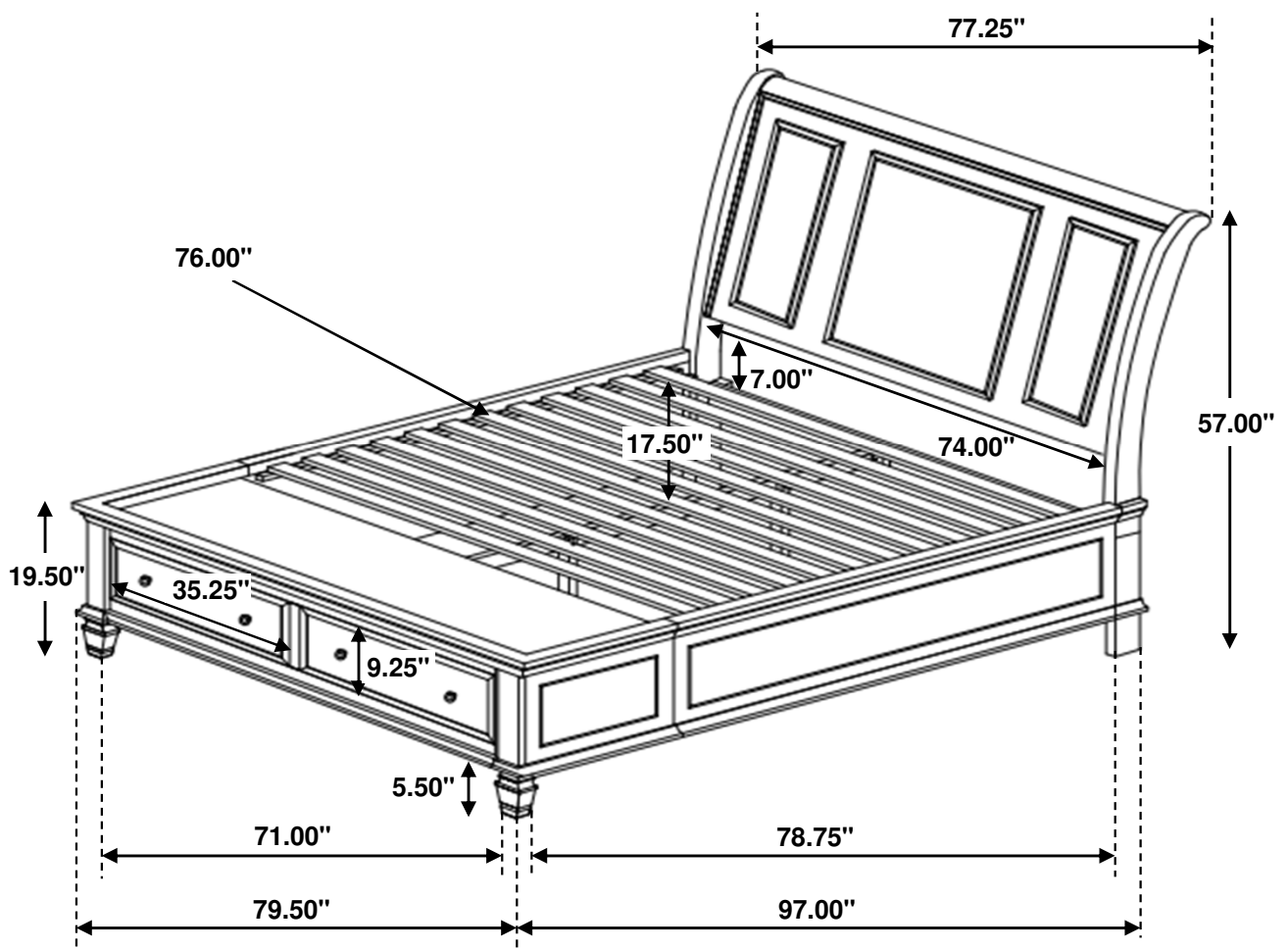

Note : Dimension tolerance $\pm 5\%$