

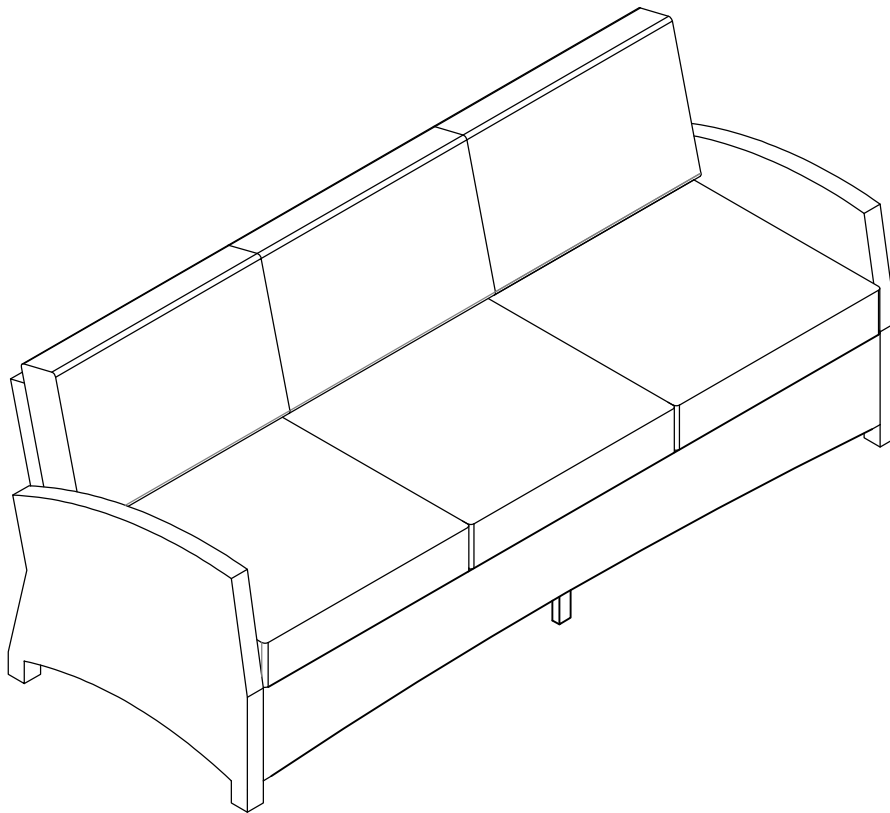

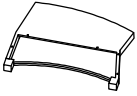

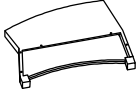

# Installation & Assembly

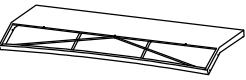
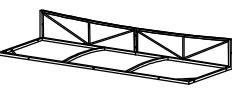



## A Sofa



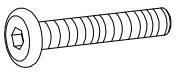
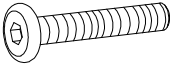
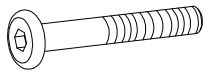

## Part List

<p><b>A</b></p> 	<p><b>B</b></p> 	<p><b>C</b></p> 	<p><b>D</b></p> 	<p><b>E</b></p> 
<p>Left Arm Panel 1PC</p>	<p>Right Arm Panel 1PC</p>	<p>Back Panel 1PC</p>	<p>Seat Panel 1PC</p>	<p>Center Leg 1PC</p>
<p><b>F</b></p> 	<p><b>G</b></p> 	<p><b>H</b></p> 	<p><b>I</b></p> 	
<p>Cover Of Seat Cushion 3PCS</p>	<p>Inner Of Seat Cushion 3PCS</p>	<p>Cover Of Back Cushion 3PCS</p>	<p>Inner Of Back Cushion 3PCS</p>	

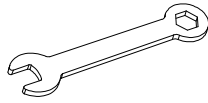
## Hardware List

<p><b>#1</b></p>  <p>M6*45mm</p>	<p><b>#2</b></p>  <p>M6*55mm</p>	<p><b>#3</b></p>  <p>M6*65mm</p>	<p><b>#4</b></p>  <p>M6mm</p>	<p><b>#5</b></p>  <p>M6mm</p>
<p>Short Bolt 2PCS</p>	<p>Medium Bolt 6PCS</p>	<p>Long Bolt 7PCS</p>	<p>Washer 22PCS</p>	<p>Nut 7PCS</p>
<p><b>#6</b></p>  <p>M6mm</p>	<p><b>#7</b></p>  <p>M6mm</p>			
<p>Allen Key 1PC</p>	<p>Wrench 1PC</p>			

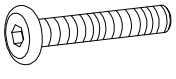
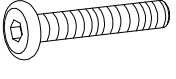
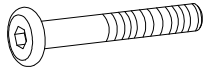
## Extra Hardware List

<p><b>#1</b></p>  <p>M6*45mm</p>	<p><b>#2</b></p>  <p>M6*55mm</p>	<p><b>#3</b></p>  <p>M6*65mm</p>	<p><b>#4</b></p>  <p>M6mm</p>	<p><b>#5</b></p>  <p>M6mm</p>
<p>Short Bolt 1PC</p>	<p>Medium Bolt 1PC</p>	<p>Long Bolt 1PC</p>	<p>Washer 2PCS</p>	<p>Nut 1PC</p>

## Sofa Assembly

Step 1. Lay left arm panel (part A) down on a soft flat surface, such as carpet, as shown below. Attach back panel (part C) to assembled unit (parts B & C) using medium bolts (part 2), flat washers (part 4) and allen key (part 6).

NOTE: Please do not fully tighten bolts until unit is fully assembled.

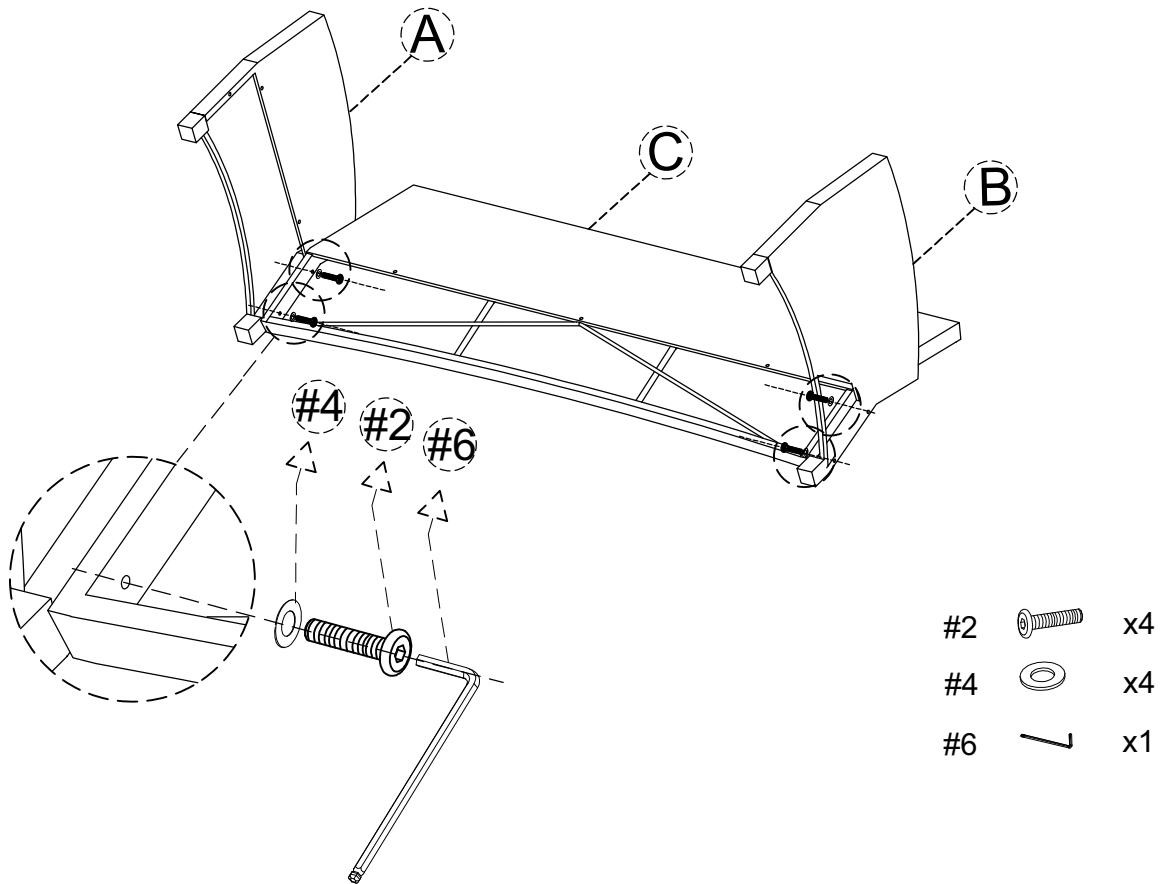

Step 2. Attach seat panel (part D) to assembled unit (parts A, B & C) using long bolts (part 3), flat washers (part 4), nuts (part 5), allen key (part 6) and wrench (part 7).

NOTE: Please do not fully tighten bolts until unit is fully assembled.

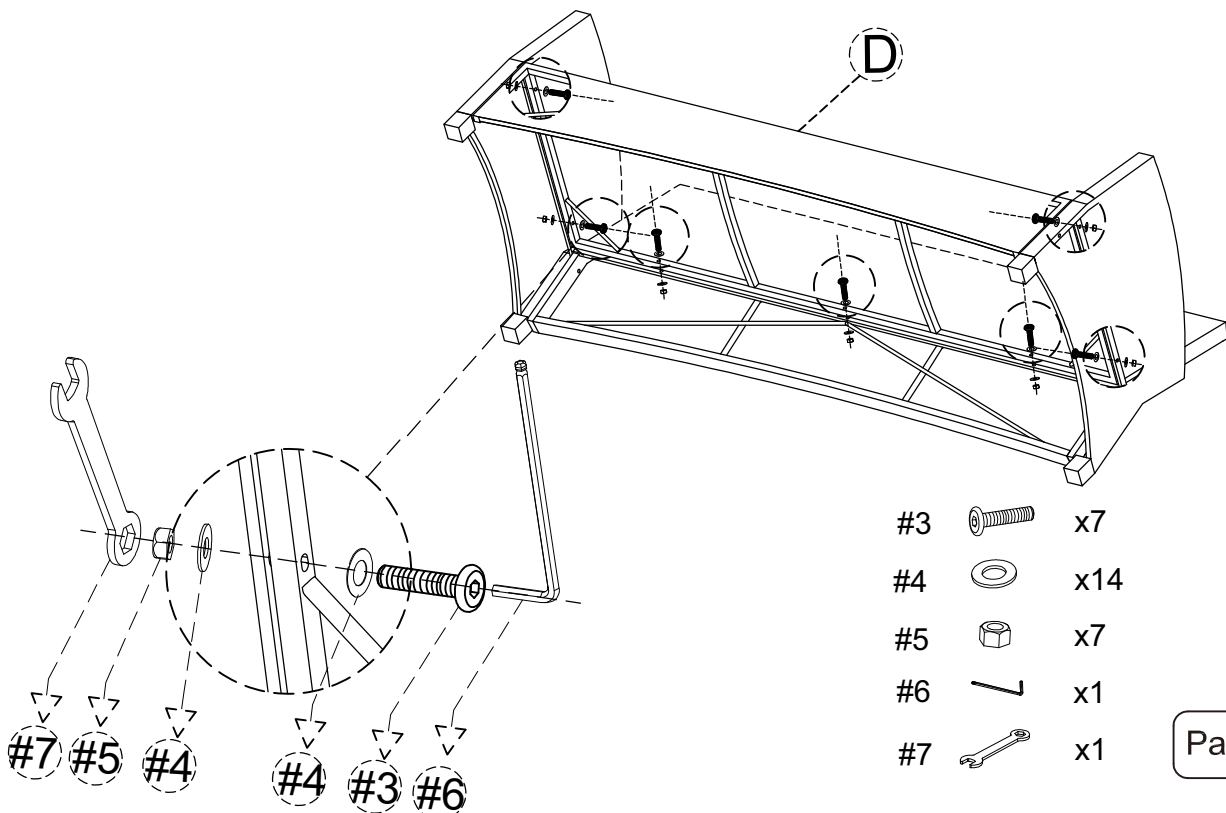

Step 3. Attach center leg (part G) to assembled unit (parts A,B,C&D) using short bolts (part 1), medium bolts (part 2), flat washers (part 3) and allen key (part 5) .

NOTE:Please fully tighten all bolts at this time.

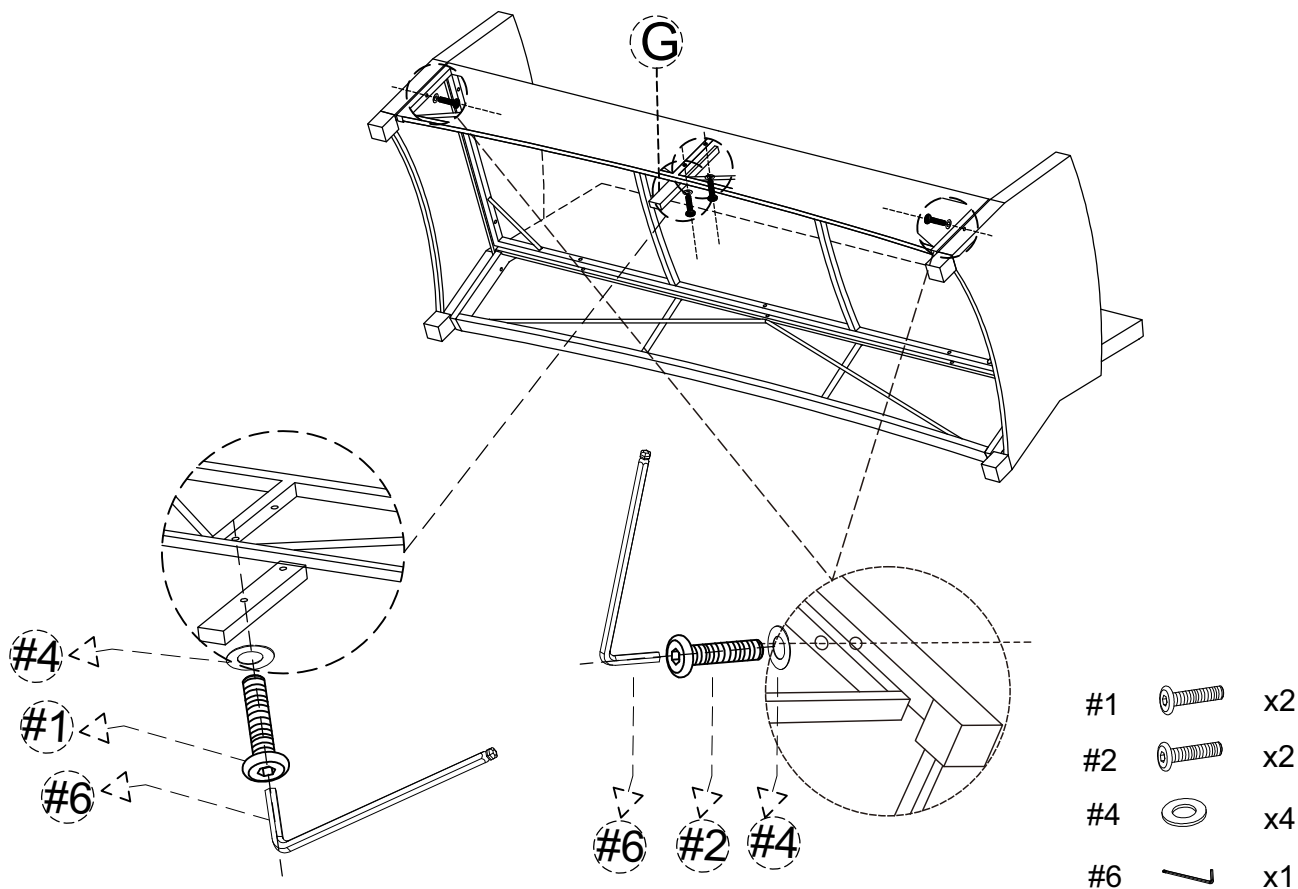

Step 4. Insert inner of seat cushion (G) into cover of seat cushion (F).  
Insert inner of back cushion (I) into cover of back cushion (H).

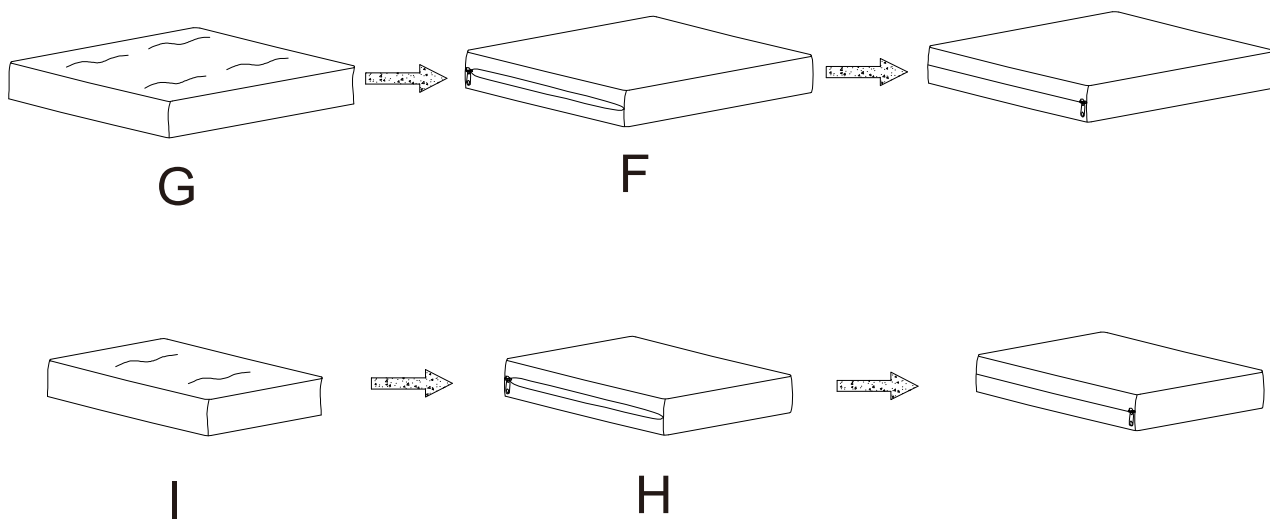

Step 5. Place the assembled furniture in your desired location. Add seat cushions and back cushions. Enjoy!

