

ASSEMBLY

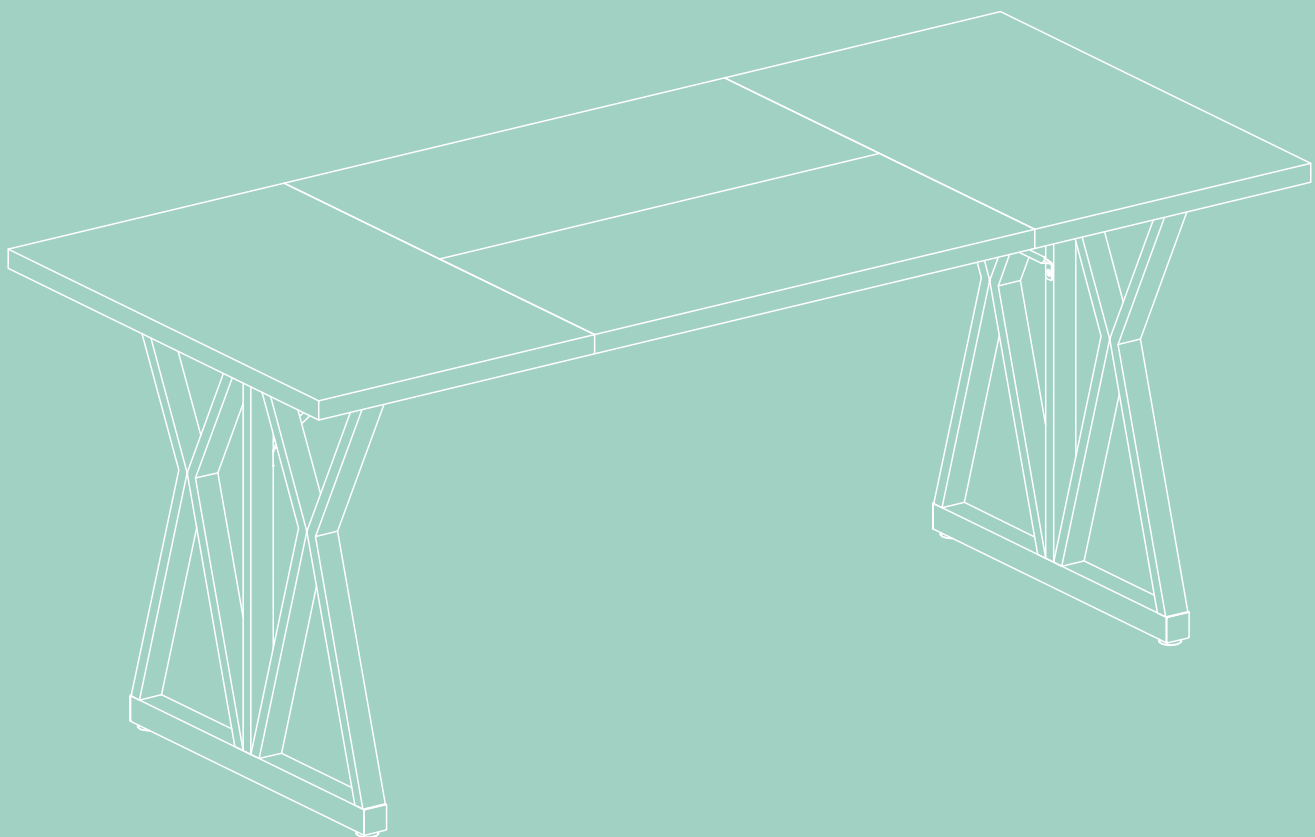

INSTRUCTIONS



Made in China

THIS INSTRUCTIONS CONTAINS IMPORTANT SAFETY INFORMATION.
PLEASE READ BEFORE ASSEMBLY AND KEEP FOR FUTURE REFERENCE



Assembly Notes

1. Please unpack all parts carefully before attempting to assemble, and ensure all parts are included and complete.
2. Assemble this item on a flat carpet or other soft places to avoid scratching and damaging the surface of items.
3. Please pay attention to how tight the screws need to be at each step.
4. We highly recommend watching the installation video for this product to make setup quicker and easier. If you encounter any problems during the assembly, please email with order ID and detailed description and we will provide you with professional technical support.



Precautions

1. There are small screws in the package, please keep them out of reach of children to prevent any accidents.
2. Children are forbidden to climb or play on the product to avoid any injury.
3. Keep plastic packing bags out of reach of children to avoid any potential danger.
5. This product is intended for indoor use only.
6. Keep the product away from fire sources and high temperatures. Do not expose the product to direct sunlight.
7. Maximum weight capacity: 300 lbs / 136kg. Please do not exceed the weight limitations of this item.

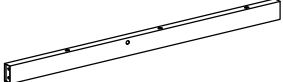
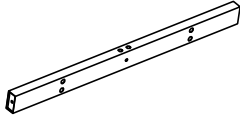
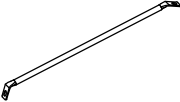
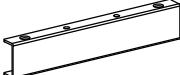
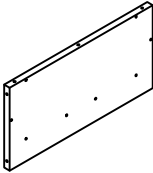
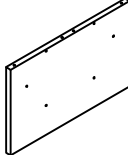
Part List

			
①×2pcs	②×1pc	③×4pcs	④×2pcs
			
⑤×2pcs	⑥×2pcs	⑦×2pcs	⑧×2pcs

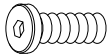
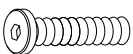
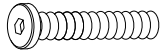
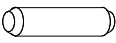
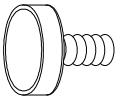
Hardware List

A	X8	B	X12+1	C	X20+2	D	X12+1
							
M6x12mm		M6x35mm		M6x55mm		M6x60mm	
E	X11+1	F	X4	G	X1		
							
Φ8x30mm		Φ32mm		M4			

Step 1

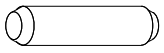

Φ8x30mm

Ⓔ × 3 pcs

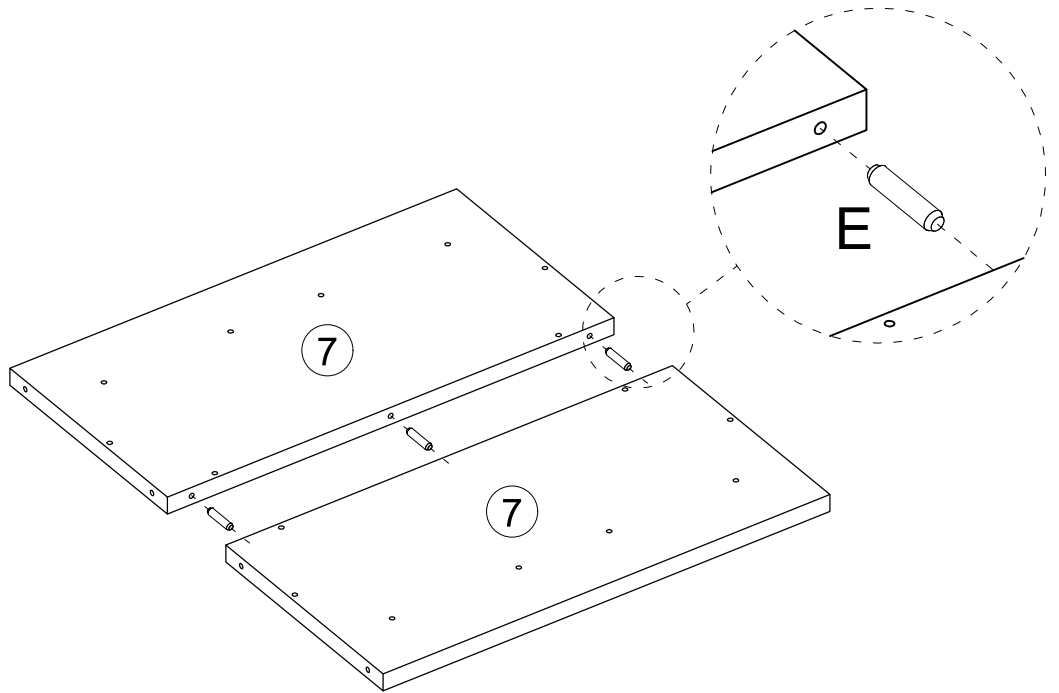

Step 2



Φ8x30mm

Ⓔ × 8 pcs

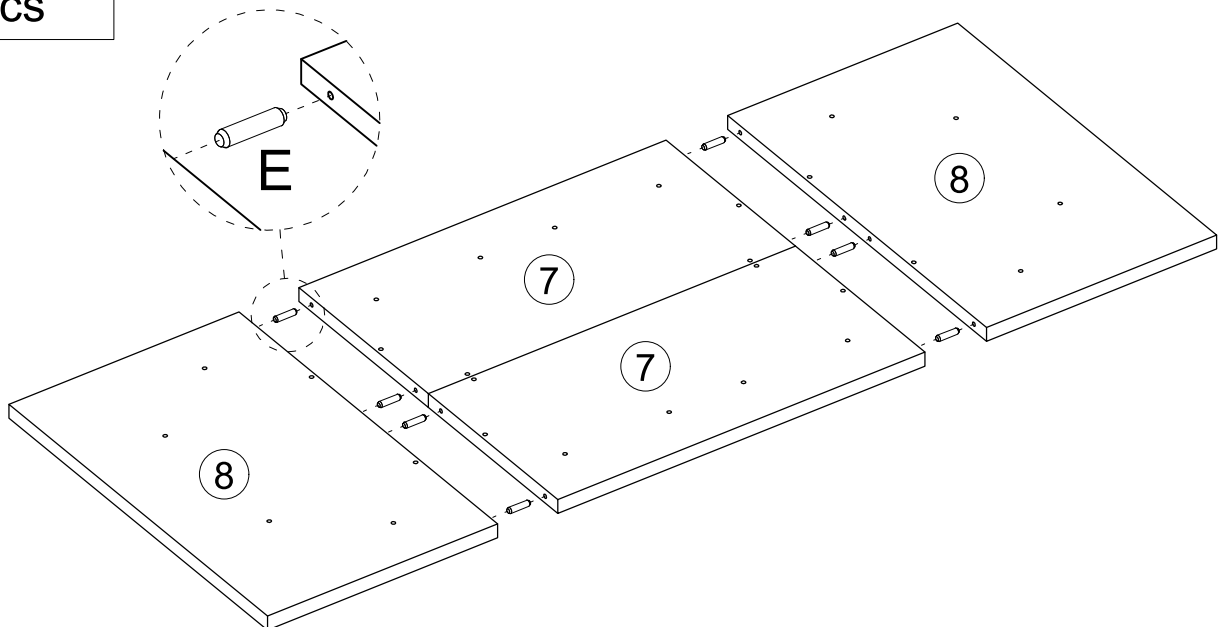

Step 3

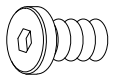

M6x12mm

Ⓐ ×4pcs

Please tighten screws to 75%.

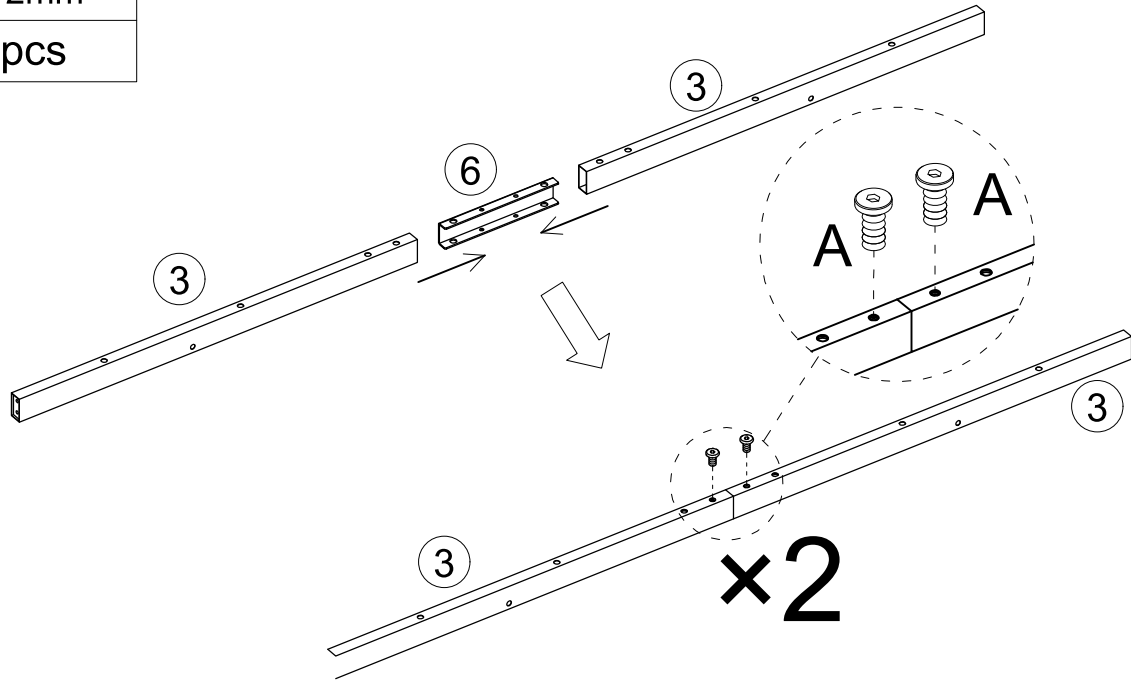
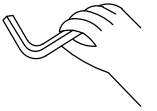
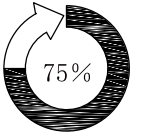

Step 4

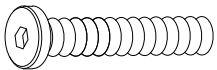

M6x60mm

Ⓓ ×4pcs

Please tighten screws to 75%.

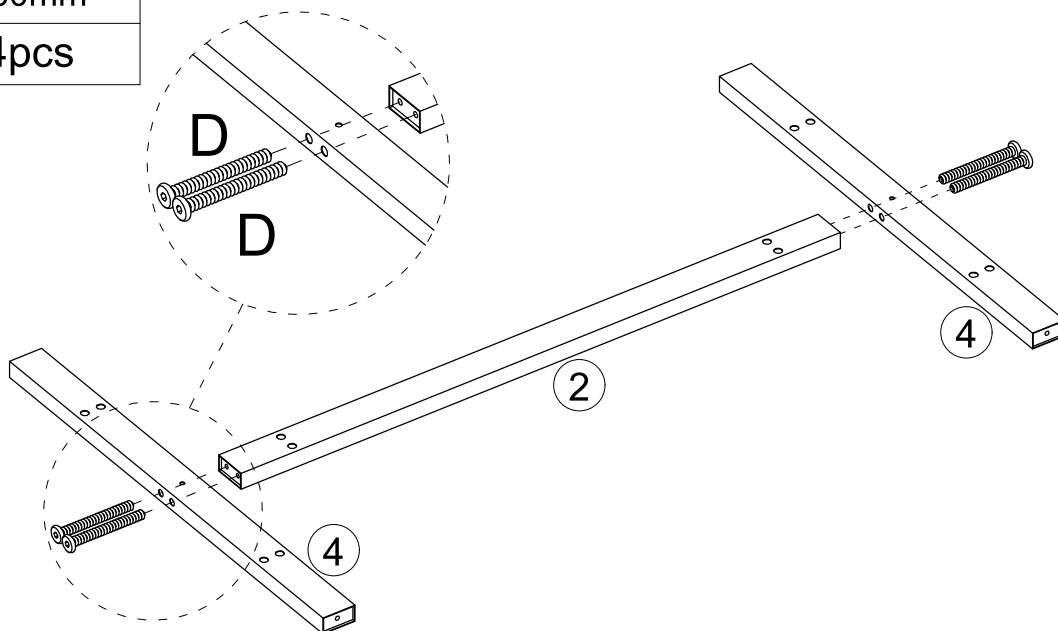
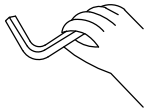

Step 5

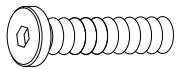

M6x55mm

Ⓒ ×4pcs

Please tighten screws to 75%.

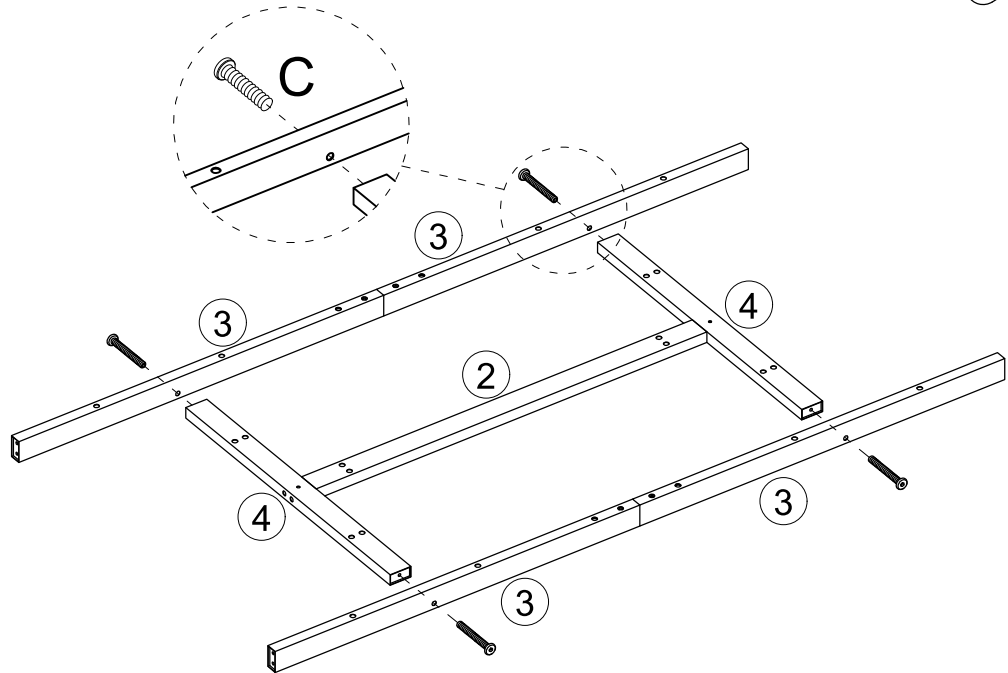
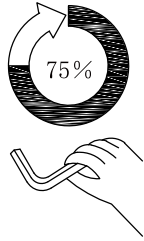

Step 6

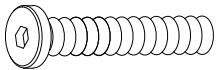

M6x60mm

Ⓓ ×8pcs

Please tighten screws to 75%.

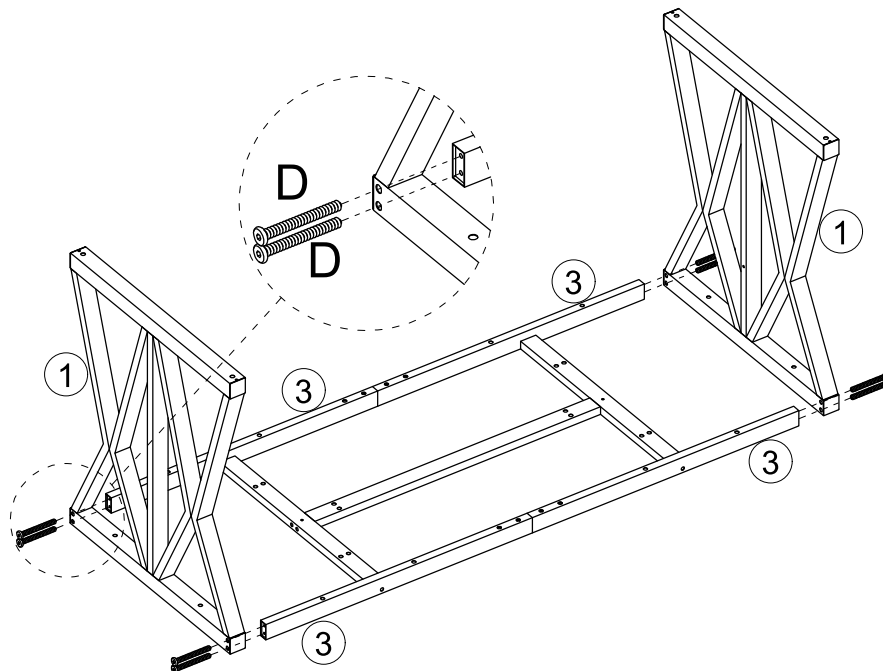
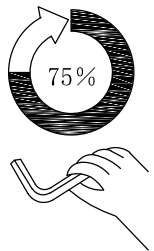

Step 7

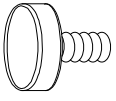

Φ32mm

F × 4pcs

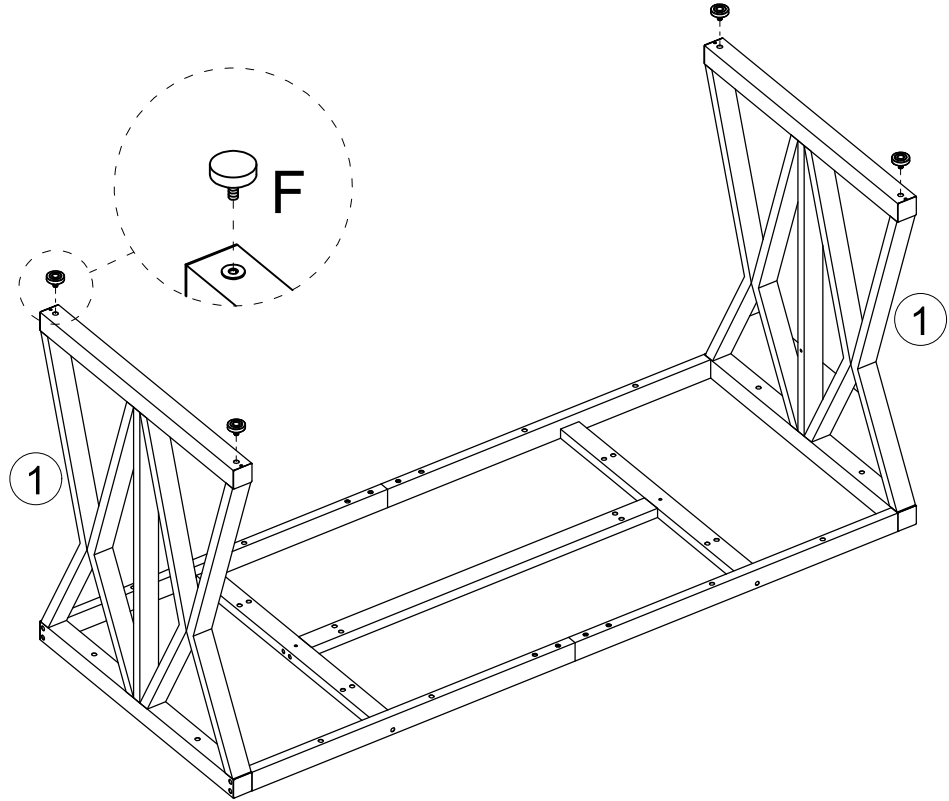

Step 8

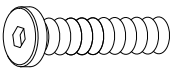

M6x55mm

C × 16pcs

Please tighten screws to 75%.

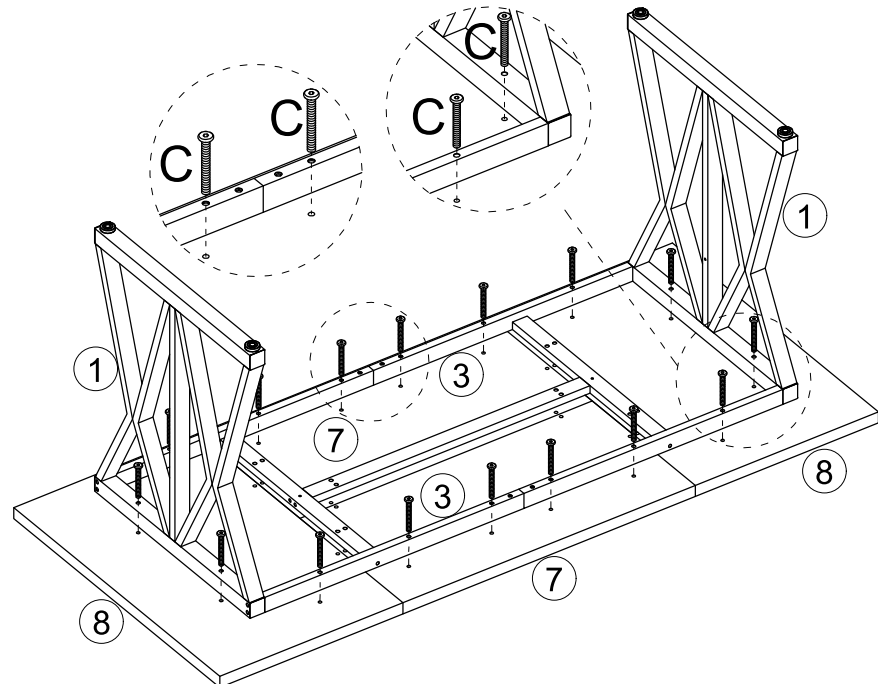
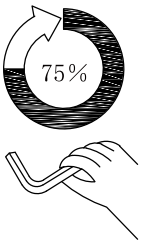

Step 9

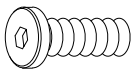

M6x35mm

Ⓑ × 12 pcs

Please tighten the screws from step 9 to 75%. Once all of them are in place, tighten all screws from steps 1-9 to 100%.

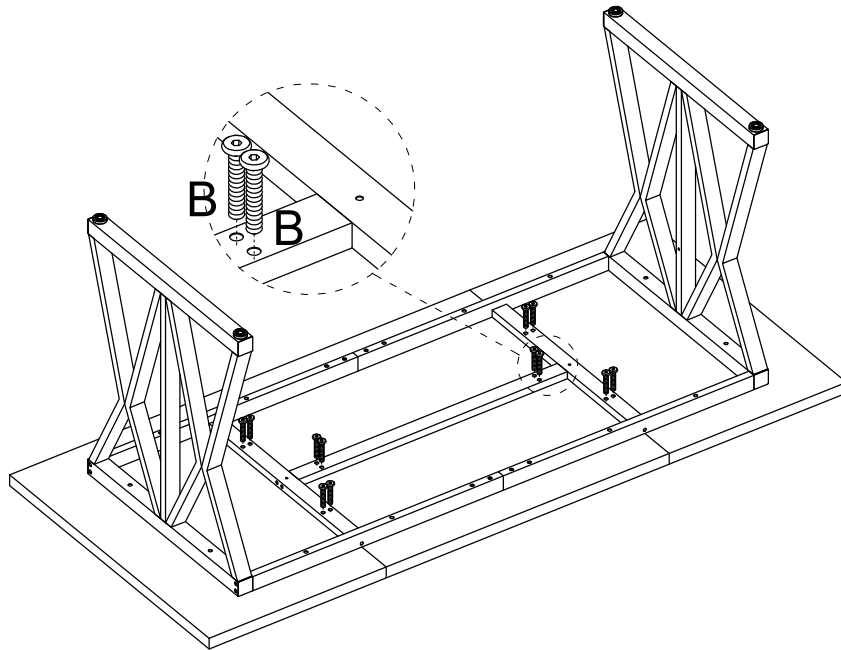
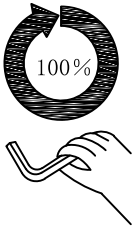

Step 10

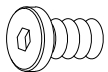

M6x12mm

Ⓐ × 4 pcs

Please tighten screws to 100%.

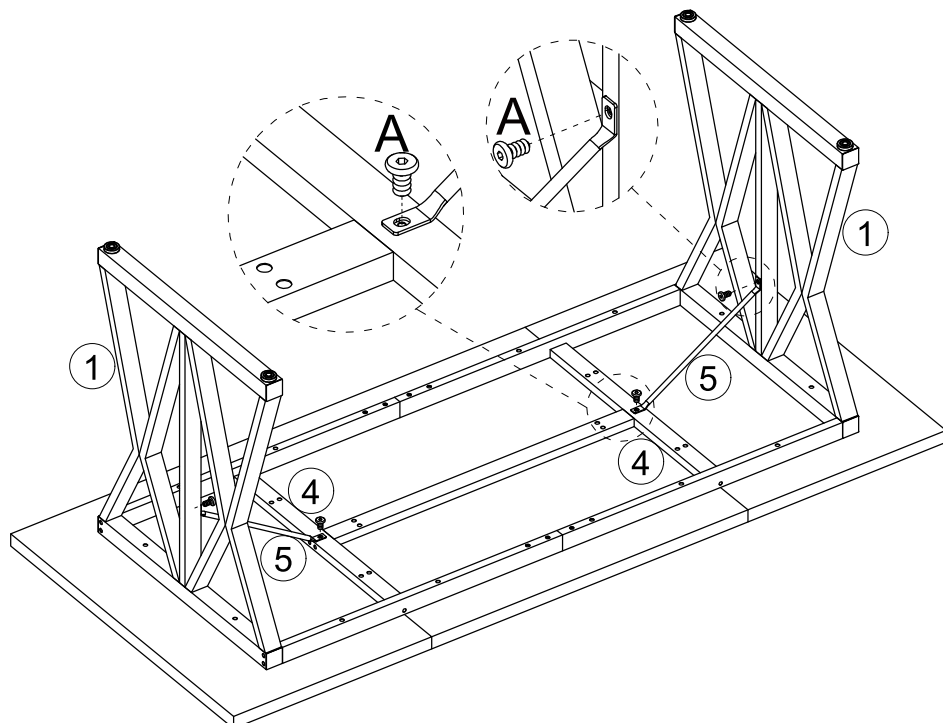
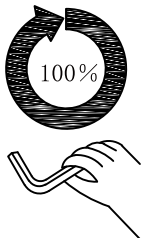

Step 11

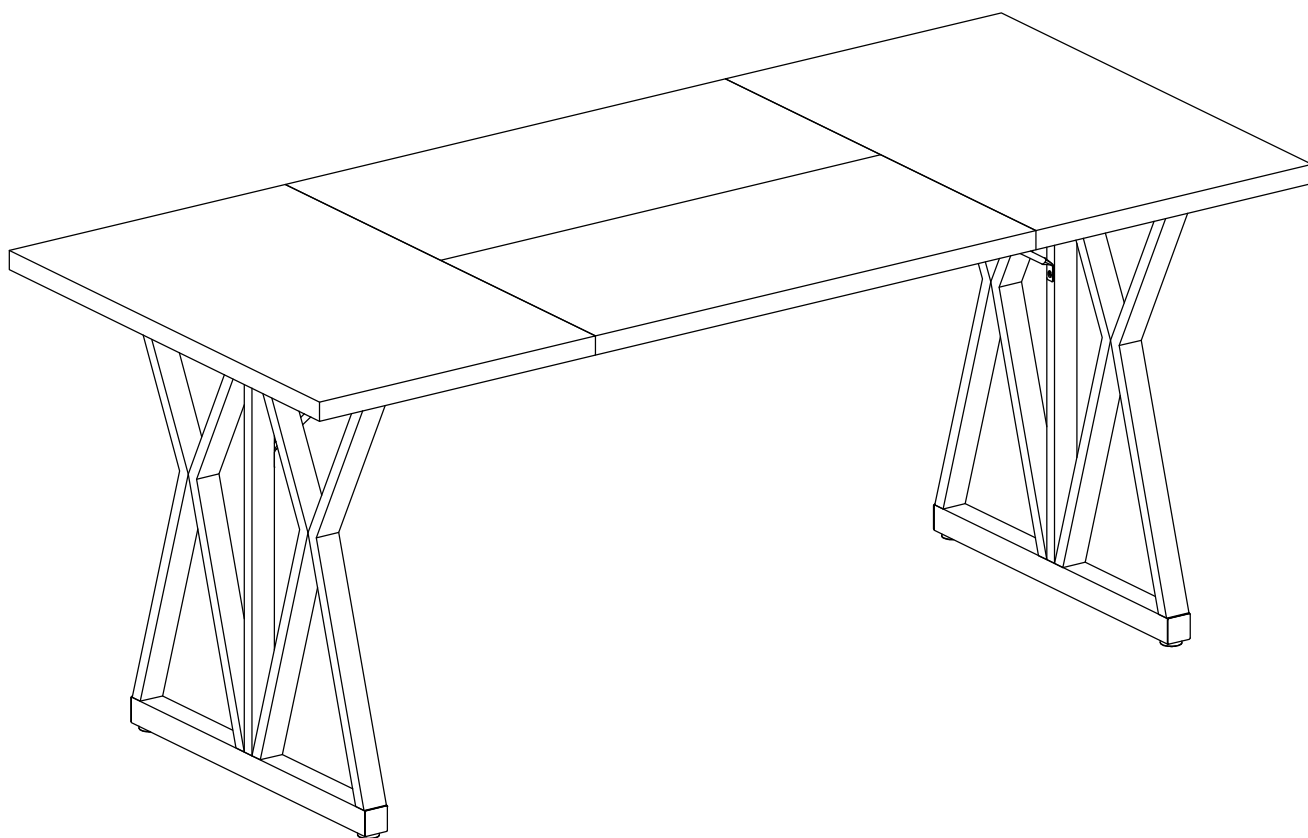

FQA & Help Center

Q1: What should I do if I receive a wrong or damaged product?

A1: Please reach out to our Customer Service Team with order ID if you receive the wrong or damaged product.

Q2: What should I do if I want to return the product?

A2: Please keep the original package and email with order ID and return reason and we will help you return it.

Q3: What should I do if I don't receive the package when the logistics track shows it has been delivered?

A3: Please email with order ID and we will send a new one to you after we confirm with the carrier.

Q4: What should I do if the logistics track has not been updated for more than 3 days?

A4: Please email with order ID and tracking number and we will urge the carrier to deliver the product to you as soon as possible.

Q5: What should I do if I have assembly problems?

A5: There is an assembly video on the product detailed page to help you finish the assembly. You could also email with order ID and detailed description and we will provide you with professional technical support.

Q6: What should I do if some parts or screws are missing?

A6: Please email with order ID and the number or letter of the missing part or screws, and we will send it to you.