

ASSEMBLY INSTRUCTIONS

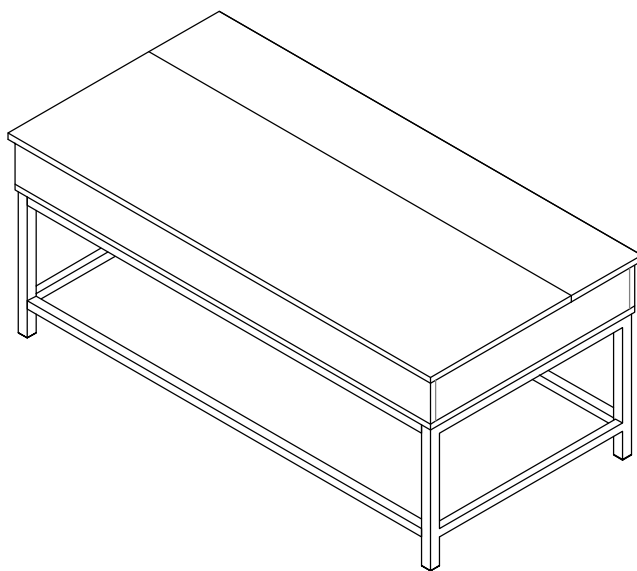

LIFT TOP COFFEE TABLE

ASSEMBLY INSTRUCTIONS

ASSEMBLY TIPS:

1. Remove hardware from box and sort by size.
2. Please check to see that all hardware and parts are present prior to start of assembly.
3. Please follow attached instructions in the same sequence as numbered to assure fast & easy assembly.



WARNING!

1. Don't attempt to repair or modify parts that are broken or defective. Please contact the store immediately.
2. This product is for home use only and not intended for commercial establishments.



ASSEMBLY TIME 20 MINUTES

PARTS IDENTIFICATION

A	TOP BOX		1PC
B	SIDE FRAME		2PCS
C	TOP CROSSBAR		2PCS
D	BOTTOM CROSSBAR		2PCS

HARDWARE IDENTIFICATION

1	SHORT BOLT (1/4" x 12mm BLK)		20PCS	3	ALLEN WRENCH (4mm)		1PC
2	CAP (25 x 25mm BLK)		4PCS				

ASSEMBLY INSTRUCTIONS

STEP 1 Do not tighten until each step is completed or instructed.

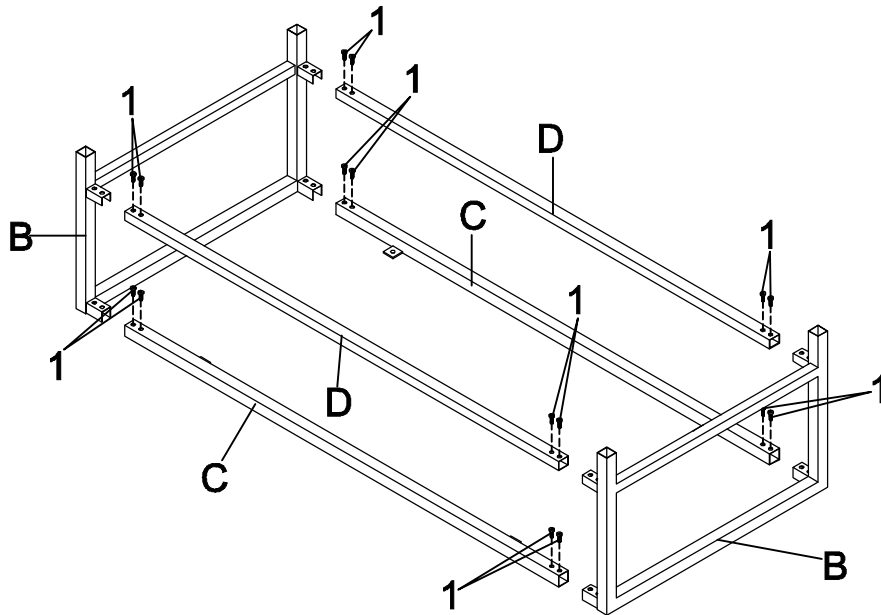

STEP 2

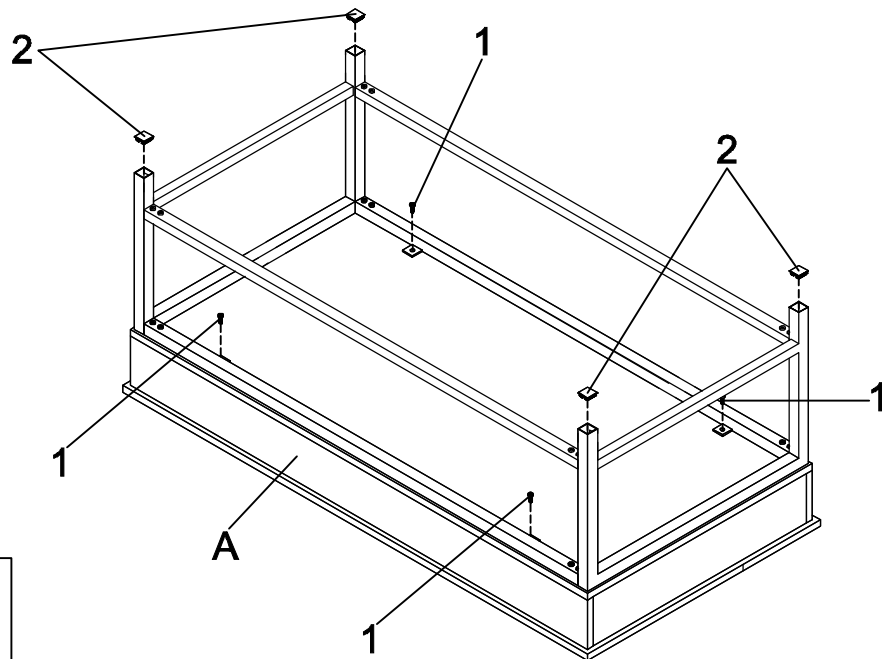

COMPLETE

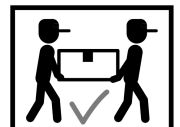
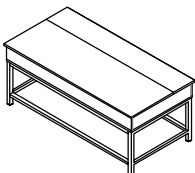

ASSEMBLY INSTRUCTIONS

Product Size : 1200 X 597 X 508 H (MM)
Product Size : 47.25" X 23.5" X 20"

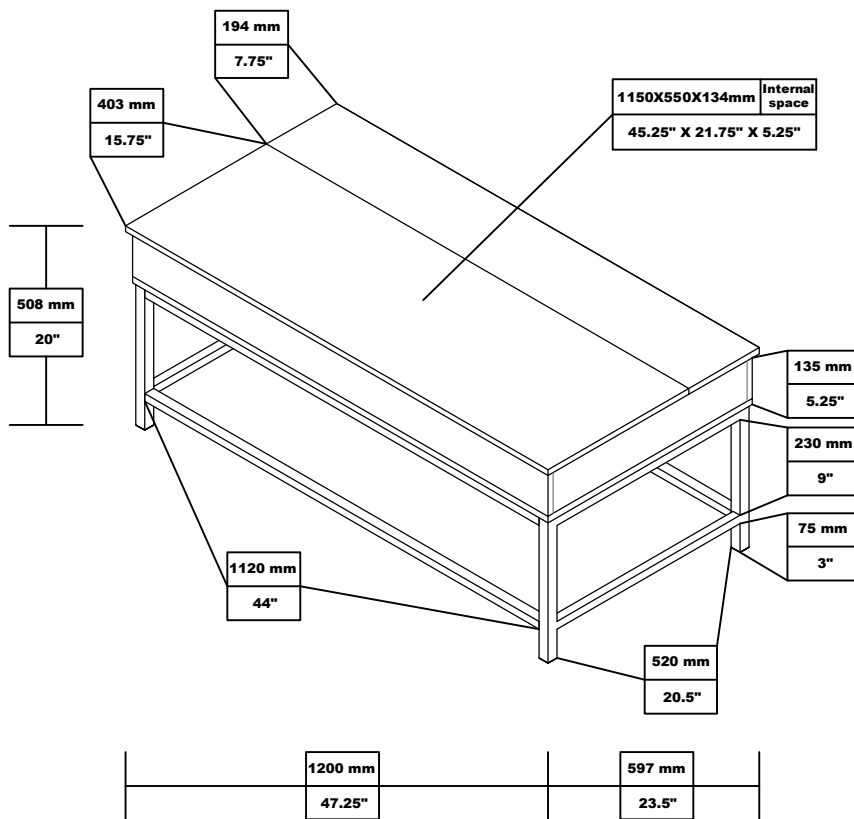

Note : Dimension tolerance $\pm 5\%$