

# BEFORE YOU GET STARTED...

*We're confident you'll love your gorgeous new furniture. However, it's worth making absolutely certain before you put it all together. So, let's quickly run through these three steps:*

## 1. COLOUR

Make sure you're happy with the colour  
No need to unpack everything, just check the first component.

## 2. PROTECTIVE PACKAGING

If you're happy, then it's time to get opening! Start by laying everything out on the protective packaging – this will prevent anything getting scratched.

## 3. PARTS PAGE

Finally, double check you have all the pieces by referencing the parts page of the instructions.

## TIPS FOR RETURNS

Not completely happy with the product? No problem. We just need everything back in the original packaging, so follow the steps below and this will ensure a super-smooth returns process and no delay to your refund.

DO



- Check everything is there (the 'parts page' is a handy checklist).
- Pop all the loose fittings and fixtures into the packaging provided or tie them up in a plastic bag.
- Wrap all the big components back up in the original protective packaging.
- Close up the box and seal it securely (don't be afraid to use plenty of tape).

DON'T



- Leave anything assembled - all components should be dismantled and separately packed.
- Put loose fixtures and fittings straight into the box.
- Throw it back in the box carelessly – as it may get damaged.

# Assembly instructions

Actual product size  
L55X W55X H55 cm

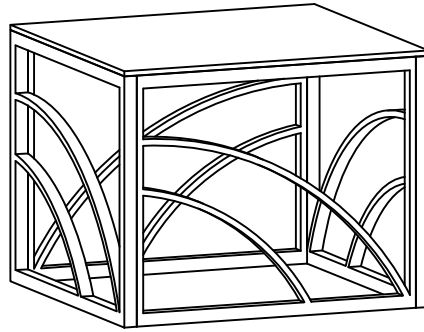

Ref	Dimensions	Visual	Qty
1	550*550mm		1
2	550*530mm		2
3	550*530mm		2

Ref	Dimensions	Visual	Qty
A	L14mm		12
B	φ15mm		12
C	φ4mm		1
D	φ15mm		4

## BEFORE YOU START

### Missing parts

If you are missing any fixtures and fittings for your product, please contact us, and we will happy to arrange for a replacement to be sent to you free of charge.

### A fault product

If you have a fault with your product please contact the seller, we will help you to make it right.

1

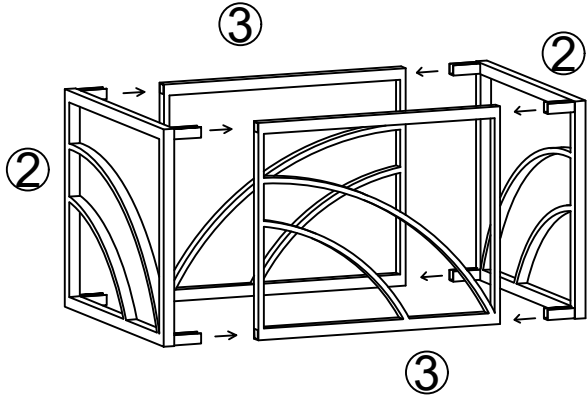

2

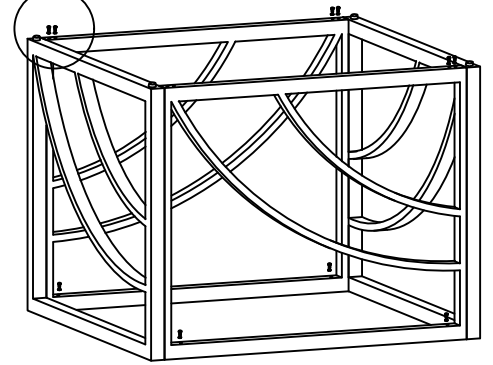
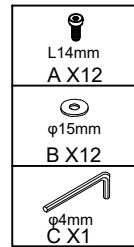
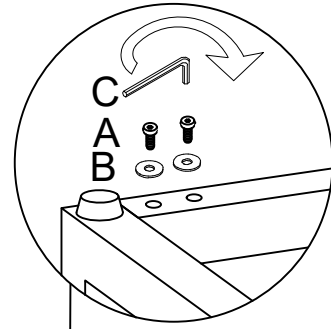

3

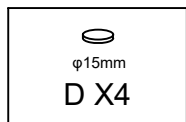
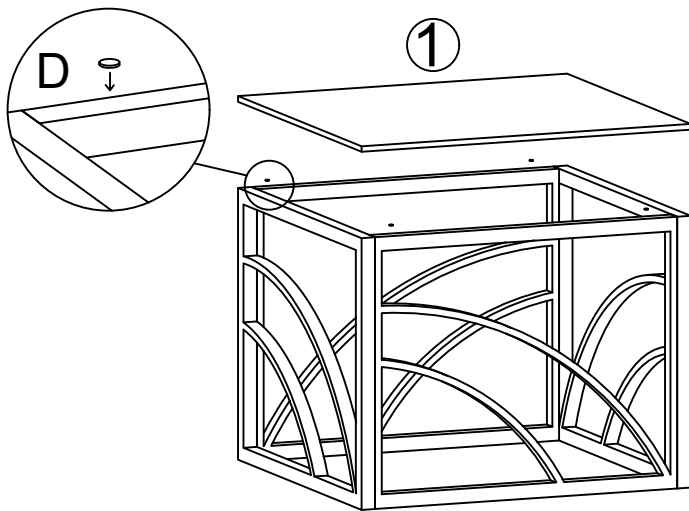

4

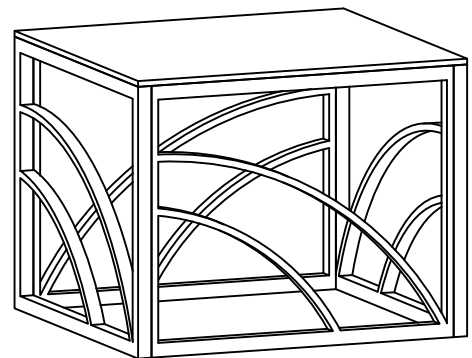

## **Warnings**

We suggest you retain these instructions for future reference.

Keep fittings out of children's reach and keep children well away from the construction area.

This product should only be used on firm, level ground.

Please periodically check all fittings and re-tighten as necessary.

Avoid exposing the furniture to excessive heat or direct sunlight as this can cause deterioration of the colour.

Unwrap all packaging materials and place the components on top of the carton box or on a clean floor to protect it from damage.

## **Do's**

We suggest you spend a short time reading through this leaflet before you start.

When you are ready to start, make sure that you have the right tools and plenty of space.

Unwrap all packaging materials and place the components on a clean surface to protect it from damage.

We recommend that the packaging is used to protect the surfaces during assembly.

Carefully check that you have all the parts before beginning assembly

Ensure the product is fully assembled as illustrated and all fixings are fully tightened before use.

## **Don'ts**

Do not drag or pull your furniture.

Do not use silicone based furniture polish. Silicone in furniture polishes can break down the finish.

Never allow any kind of liquid to remain on your furniture.