

ASSEMBLY INSTRUCTIONS

MODEL : TB8079 (1000x2000)

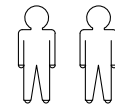

2 Persons Recommended

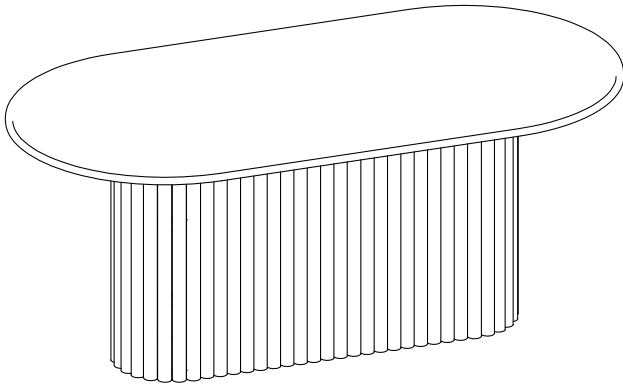

ITEM	HARDWARE LIST	DESCRIPTION	QTY
A	JCBC M8 x 70		12 PCS
B	JCBC M6 x 35		16 PCS
C	JCBC M6 x 25		12 PCS
D	Spring Washer M6		28 PCS
E	Spring Washer M8		12 PCS
F	Flat Washer M6 x 13		28 PCS
G	Flat Washer 5/16		12 PCS
H	Wood Dowel M10 x 30		16 PCS
I	Adjuster Screw 15mm		12 PCS
J	Allen Key M5 (Short)		1 PC
K	Allen Key M4 (Long)		1 PC

ITEM		QTY
1	Table Top 	1 PC
2	Top Frame 	1 PC
3	Side Leg 	2 PCS
4	Leg Panel 	2 PCS

STEP 1

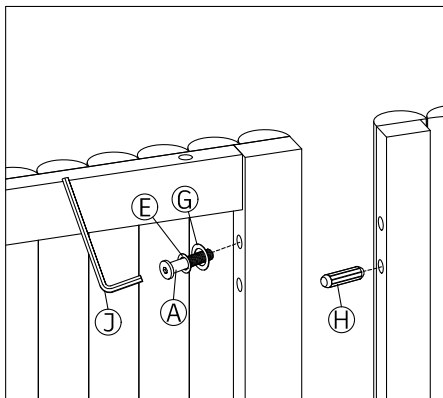

Remark: Please make sure the **arrow** at the top.

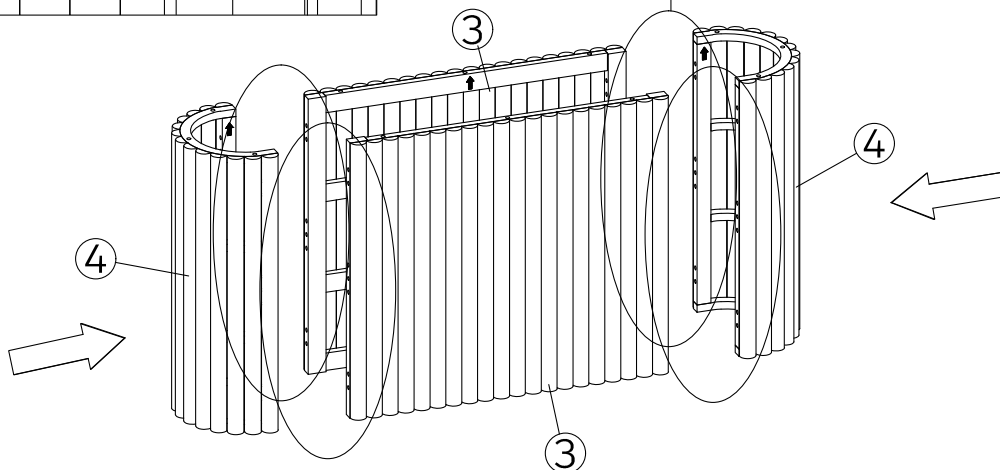

STEP 2

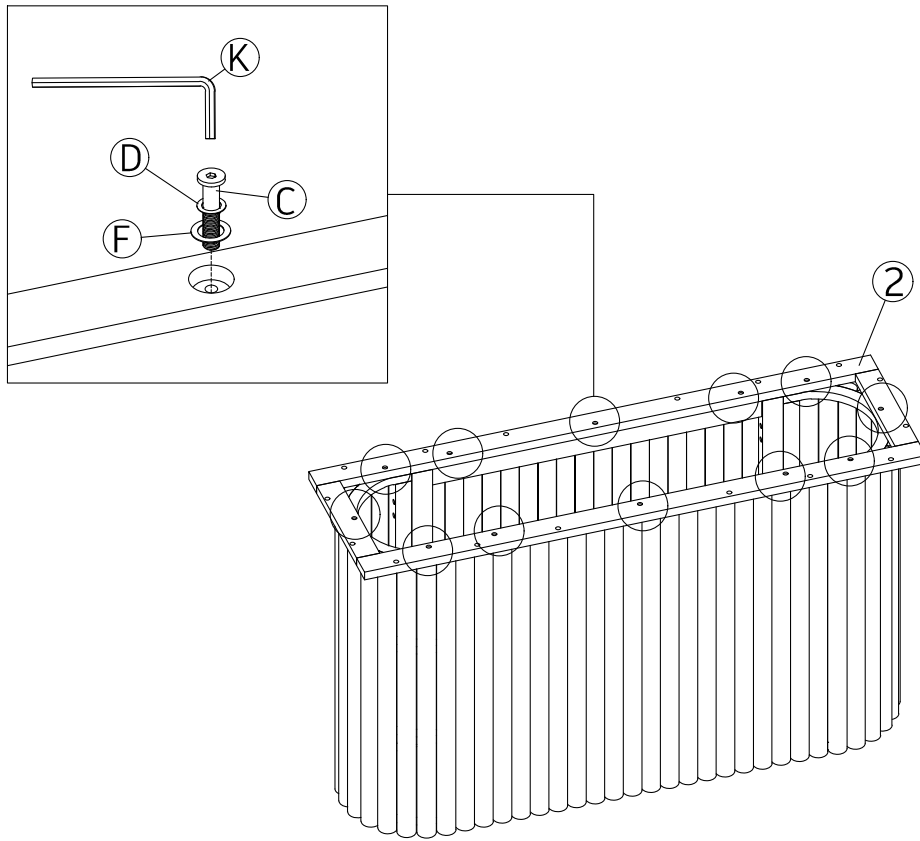

STEP 3

