













# Installation & Assembly

## Parts List

Item	Parts	Description	Quantity
A		Top Assembly	1
B		Left Side Frame	1
C		Right Side Frame	1
D		Shelf	1
E		Vertical Panel	1
F		X-rack panels	2
G		Back Panel	1

## Hardware List

Item	Hardware	Description	Quantity
1		Long Allen Bolts	6
2		Short Allen Bolts	6
3		Flat Washers	12
4		Lock Washers	12
5		Allen Wrench	1
6		Wood Screws	20

## Assembly Steps

### Step 1

- 1.1 Lay the top assembly upside down on a soft surface, cut the string and open the drawer.
- 1.2 Unfasten two bolts on second glass hanger rail to make the holes for side frame assembly accessible as shown below.

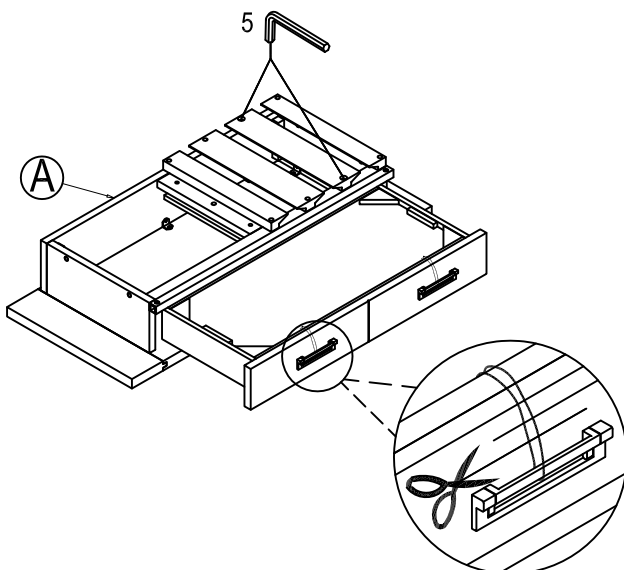

### Step 2

- 2.1 Insert the left side frame into top assembly tube, fasten with 2 long bolts and one short bolt. Do not tighten.
- 2.2 Tighten two long bolts first, and push the side frame onto the top metal tube while tightening the short bolt.

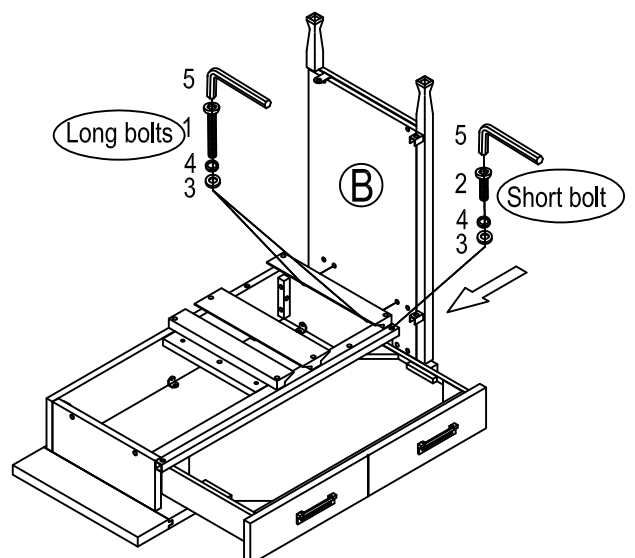

# Assembly Steps

## Step 3

3.1 Insert vertical panel's wooden dowels into top assembly holes, fasten it with one long bolt through the bottom of middle top assembly rail.

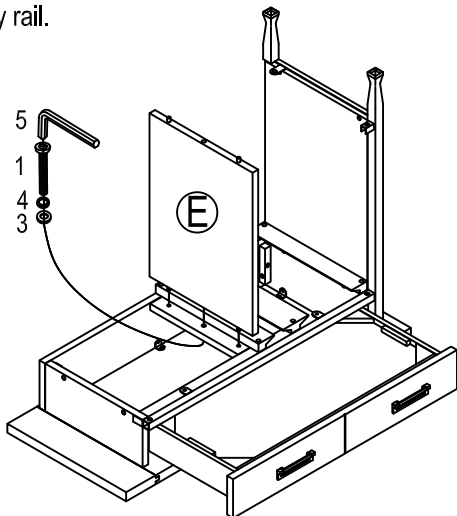

## Step 4

4.1 Insert the left side frame into the tube at the shelf's front edge, make sure the vertical panel's wooden dowels are fully inserted onto shelf. Then push the side frame and fasten the shelf with two short bolts.

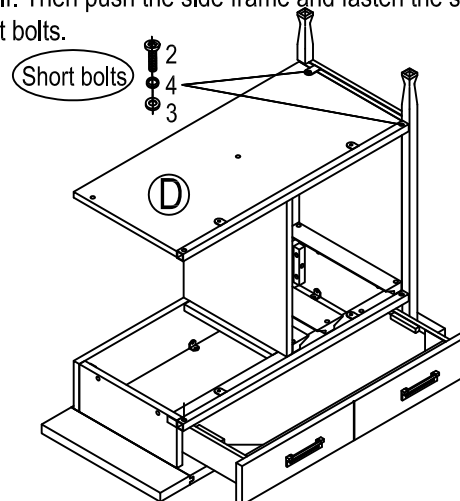

## Step 5

5.1 Fasten the right side frame with two long bolts and three short bolts.

5.2 Fasten the shelf into vertical panel with one long bolt.

5.3 Fasten the glass hanger rail onto top assembly.

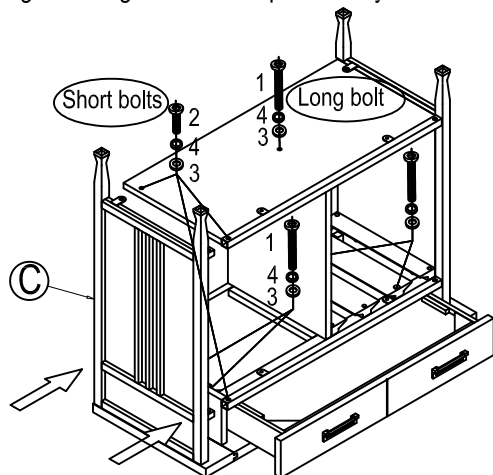

## Step 6

6.1 Place the wine cabinet right side up. Insert x-rack panel into each other.

6.2 Place x-rack into the wine cabinet from the back side.

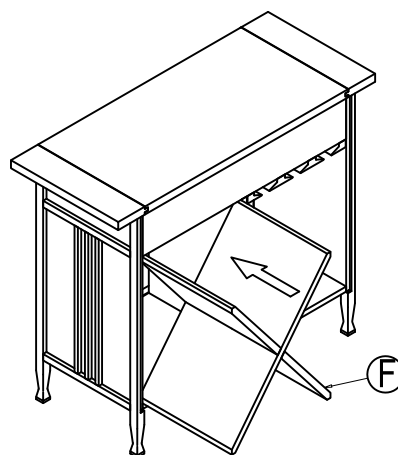

## Step 7

7.1 Unfold the back panel, place it onto the cabinet with the "up" sticker arrows on the upper left. Fasten with screws on corners first, push x-rack from the front towards the back panel and fasten with screws from the back.

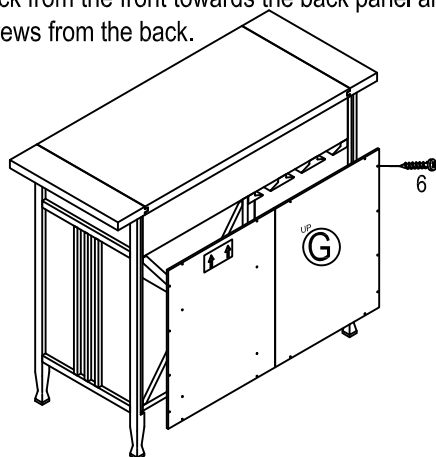

## Step 8

8.1 Adjust levelers on the bottom of legs if needed.

