

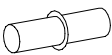















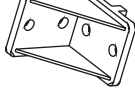

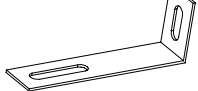
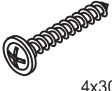







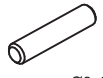

BT1005.xx  x8	BT1016  x16	BT50103  x4	BT1304  x3	BT1305  x3	BT50162.xxx  x2	BT50210  x1	BT50244.xxx  x16	BT50253  x2
BT50481  60x40x20 x4	 x1	MM1010  4x30 x2	MM1016  11mm x16	MM1018  x2	BT50101  x4	MM1017  4x16 x12		
MM1046  Ø3,5x13 x8	MM1039  4x20 x4	MM1070  Ø7x1,5 x2	MM1120  Ø8x50 x8	MM1121  Ø8x35 x12	MM1048  3x20 x4	BT50257  x2		

1.

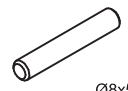
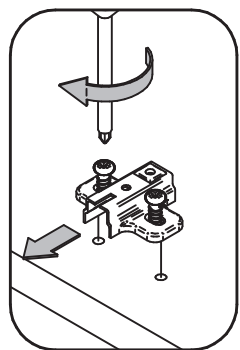
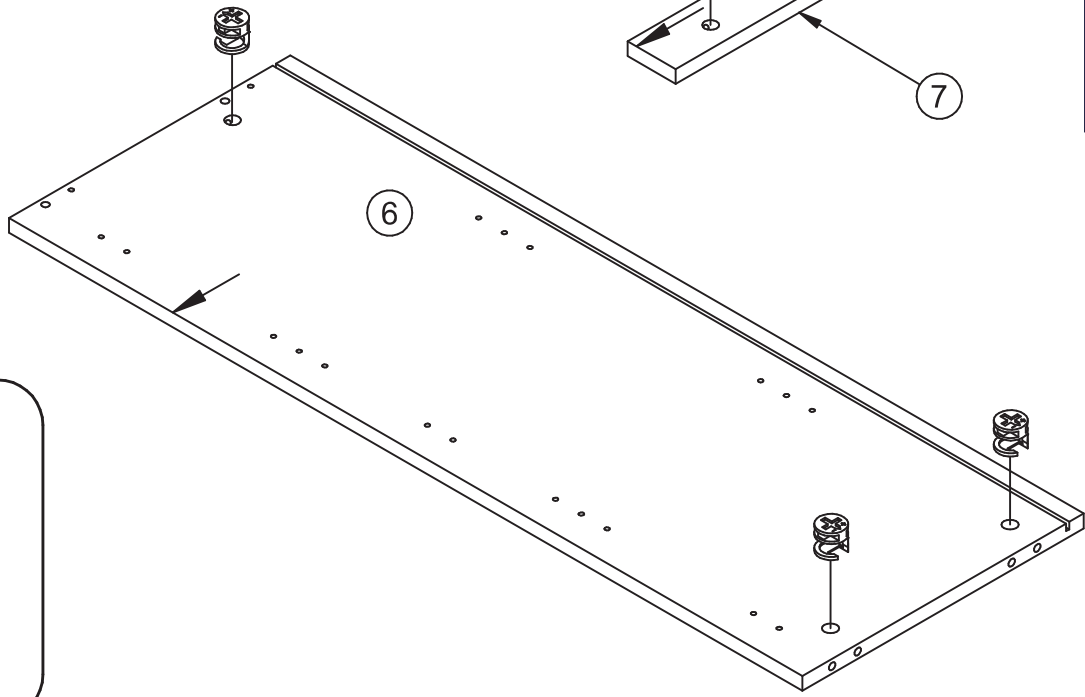
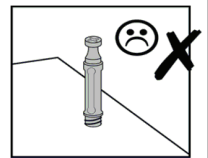
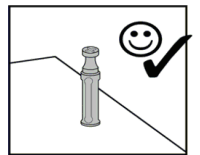
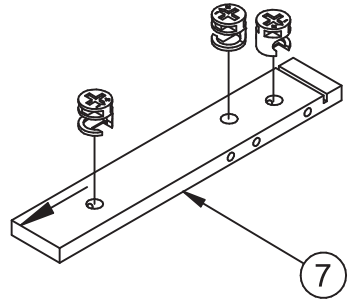
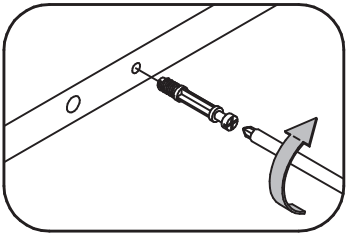
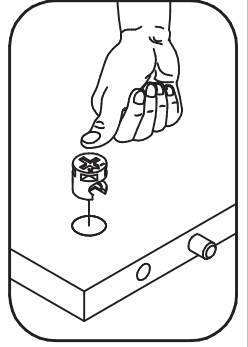
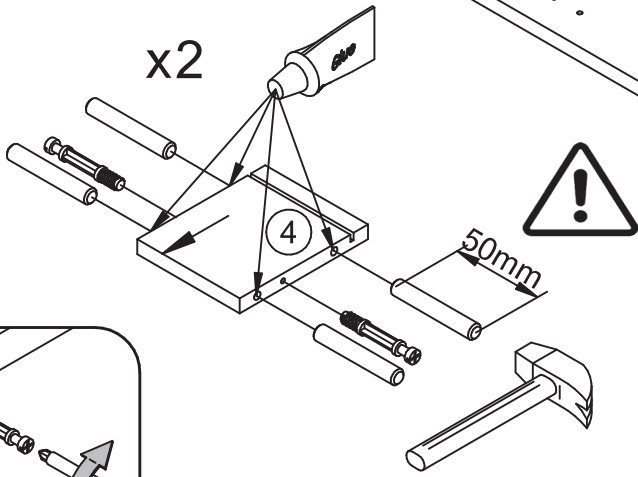
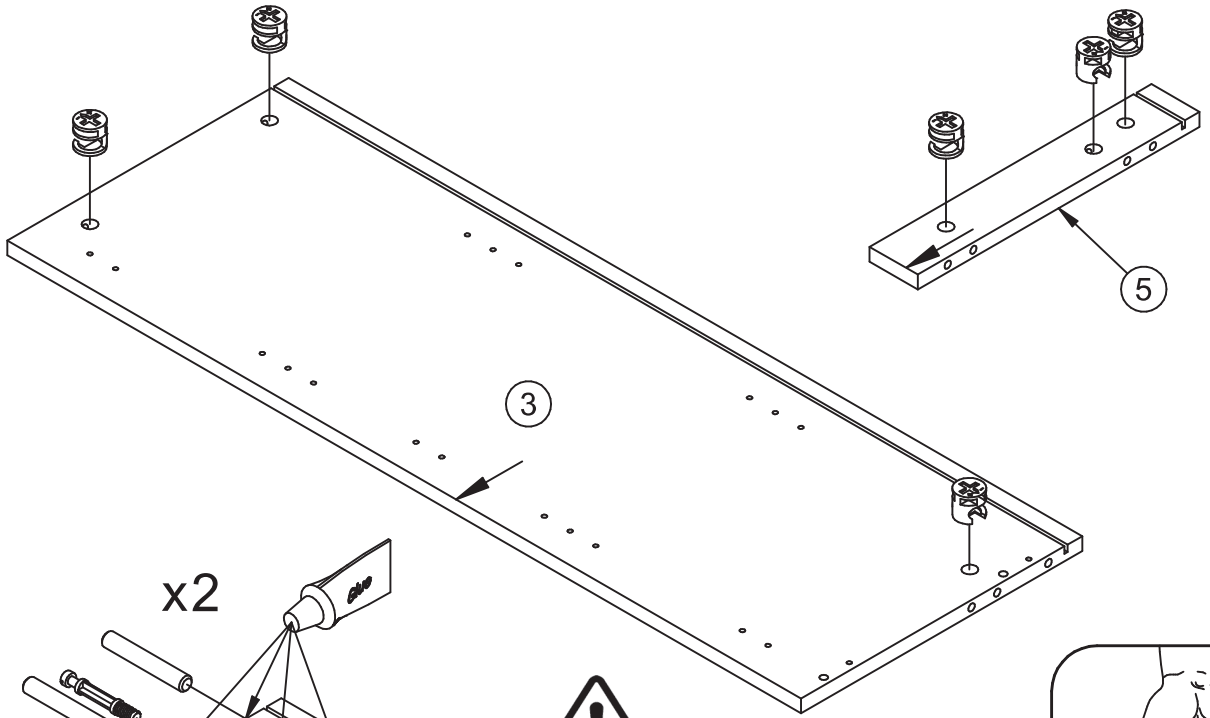
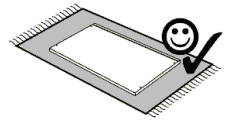
BT1016 	MM1016 	MM1018 	MM1120 
x12	x4	x1	x8 Ø8x50



2.

MM1016  x2	MM1018  x1	MM1121  x4 Ø8x35
---	---	--

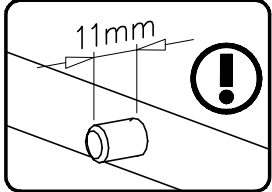
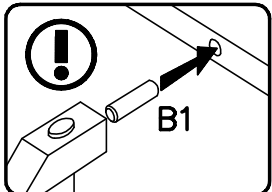
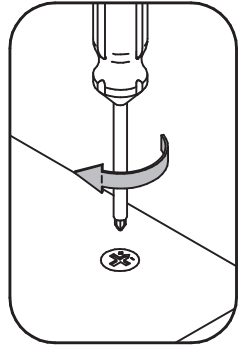
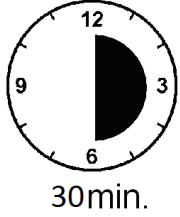
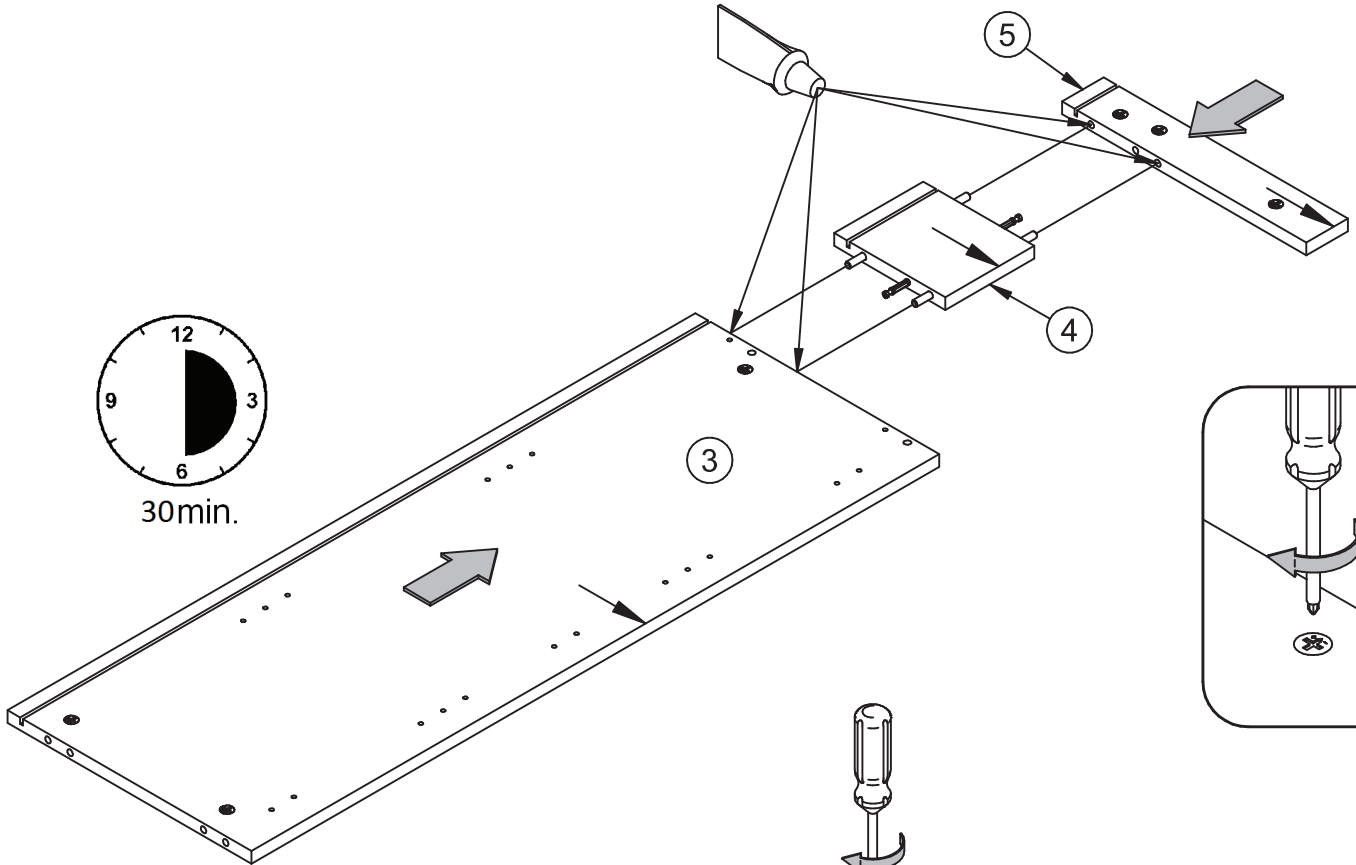
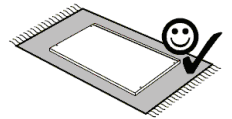

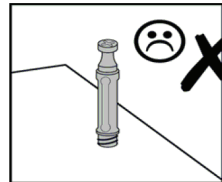
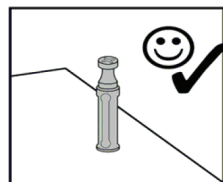
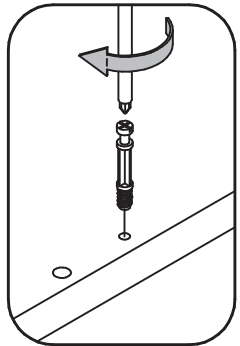
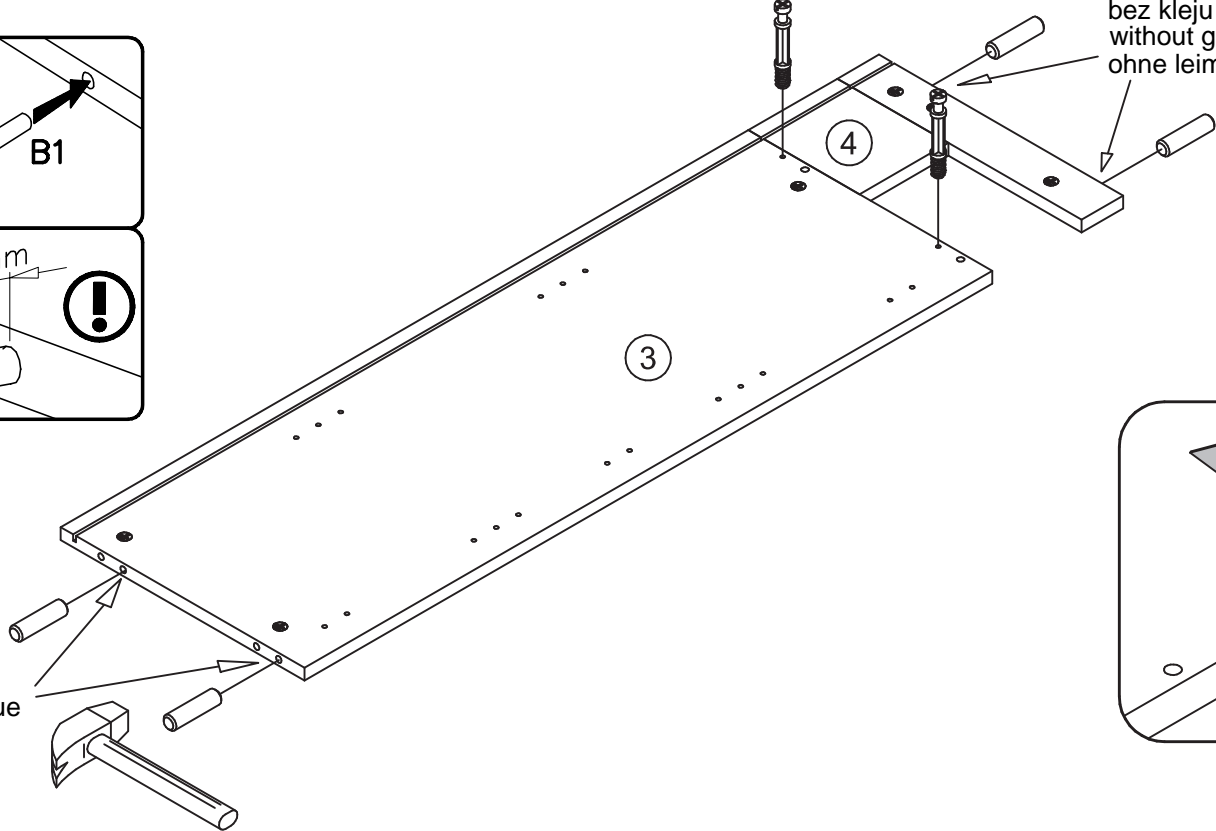

bez kleju
without glue
ohne leim

bez kleju
without glue
ohne leim



3.

MM1016  1mm x2	MM1018  x1	MM1121  Ø8x35 x4
--	---	--

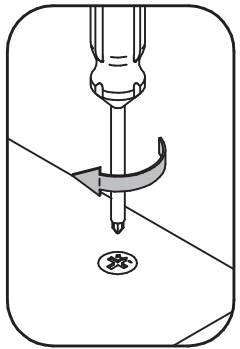
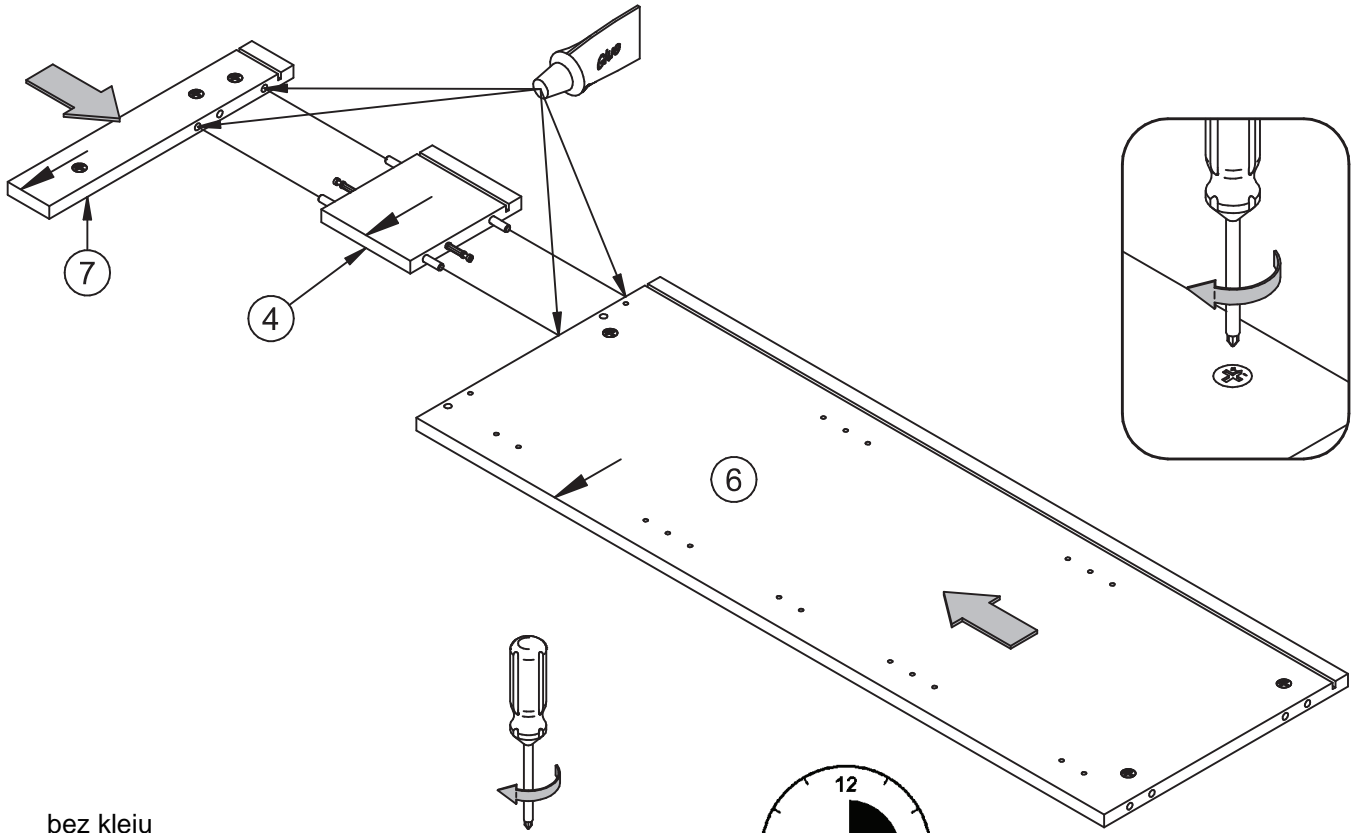
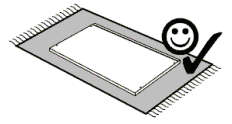

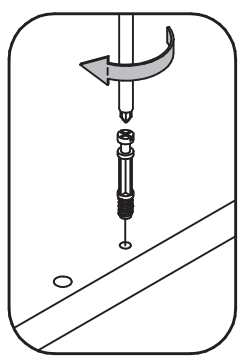
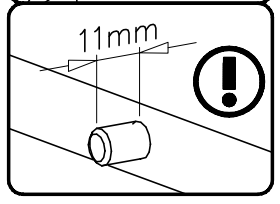
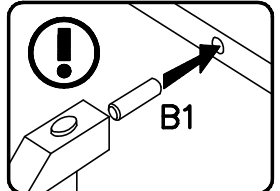
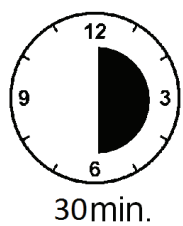

bez kleju
without glue
ohne leim

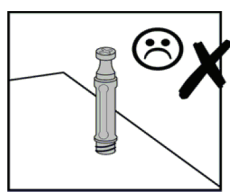
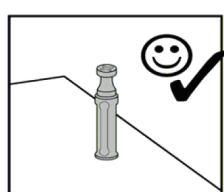

bez kleju
without glue
ohne leim



4.

BT1016 	MM1121 	MM1016 
x4	x4	x8

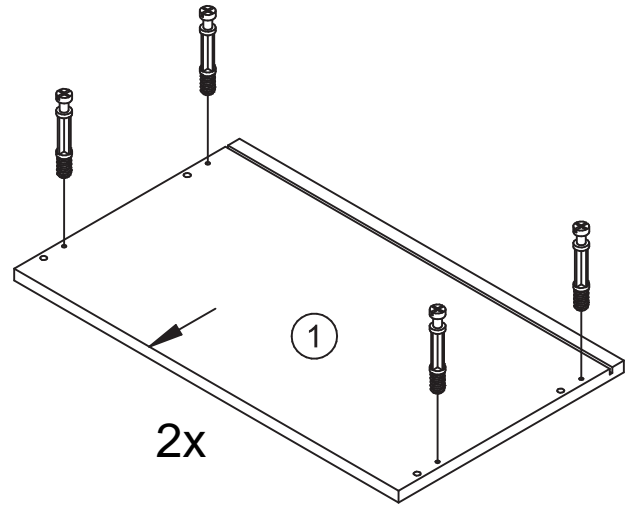
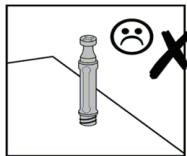
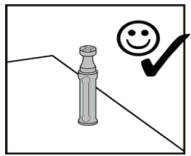
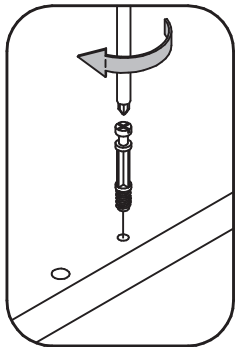
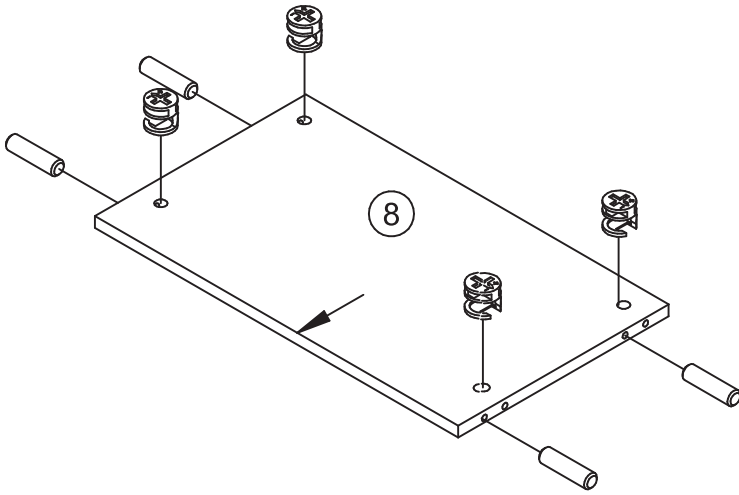
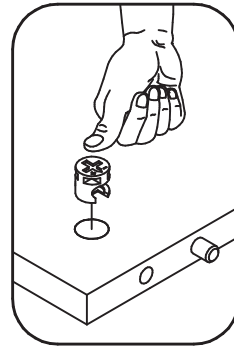
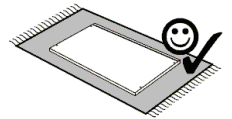

5.

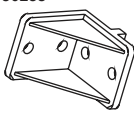
MM1017 	BT50253 
4x16 x4	x2

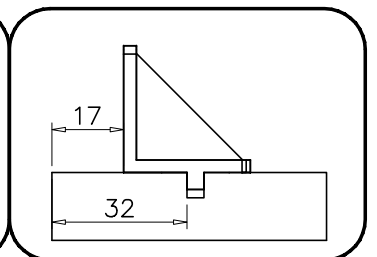
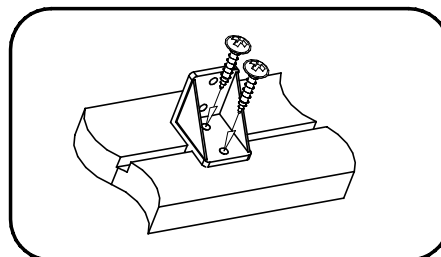
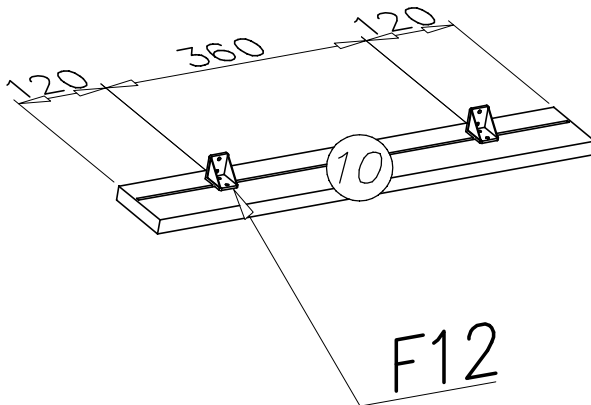
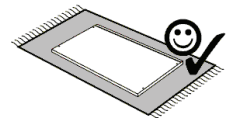

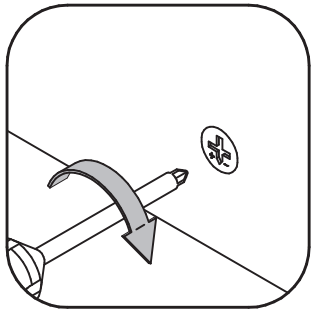
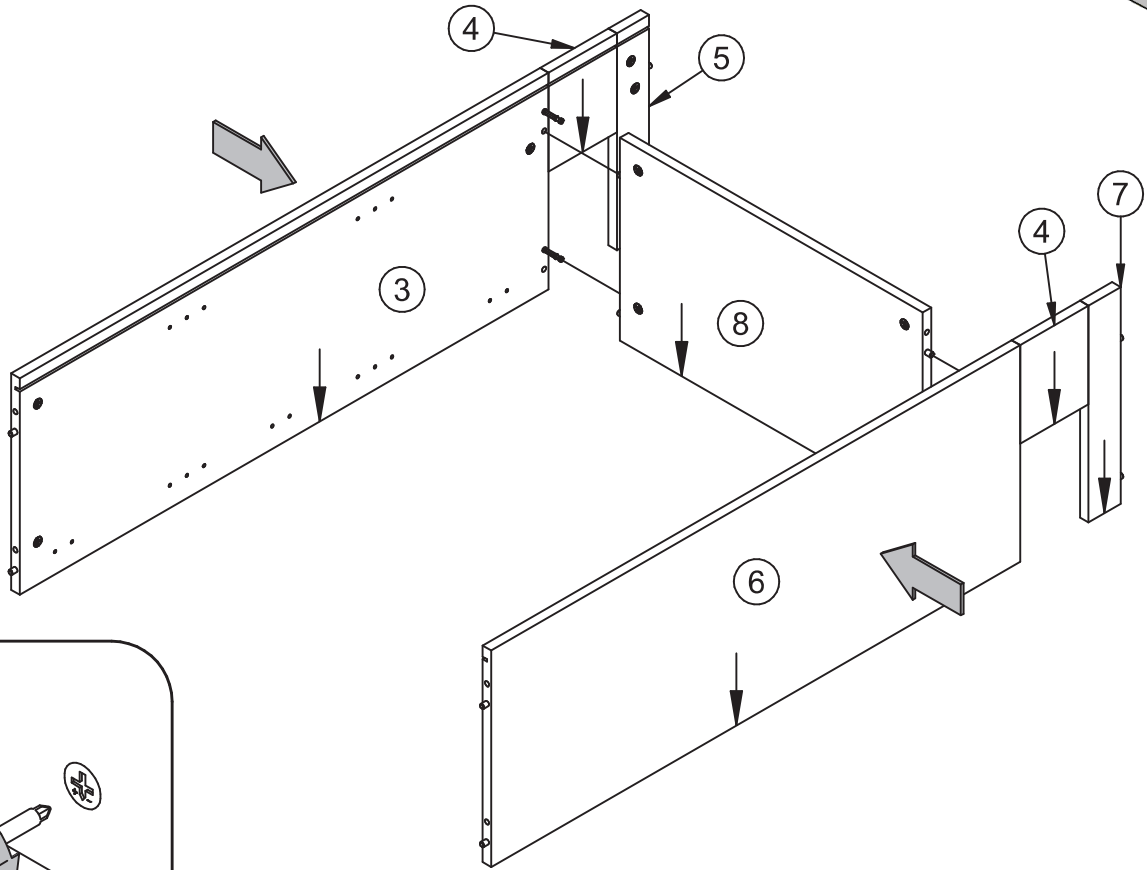
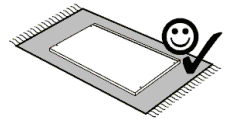

6.

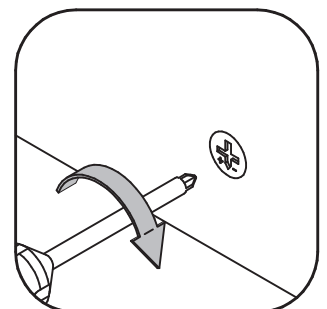
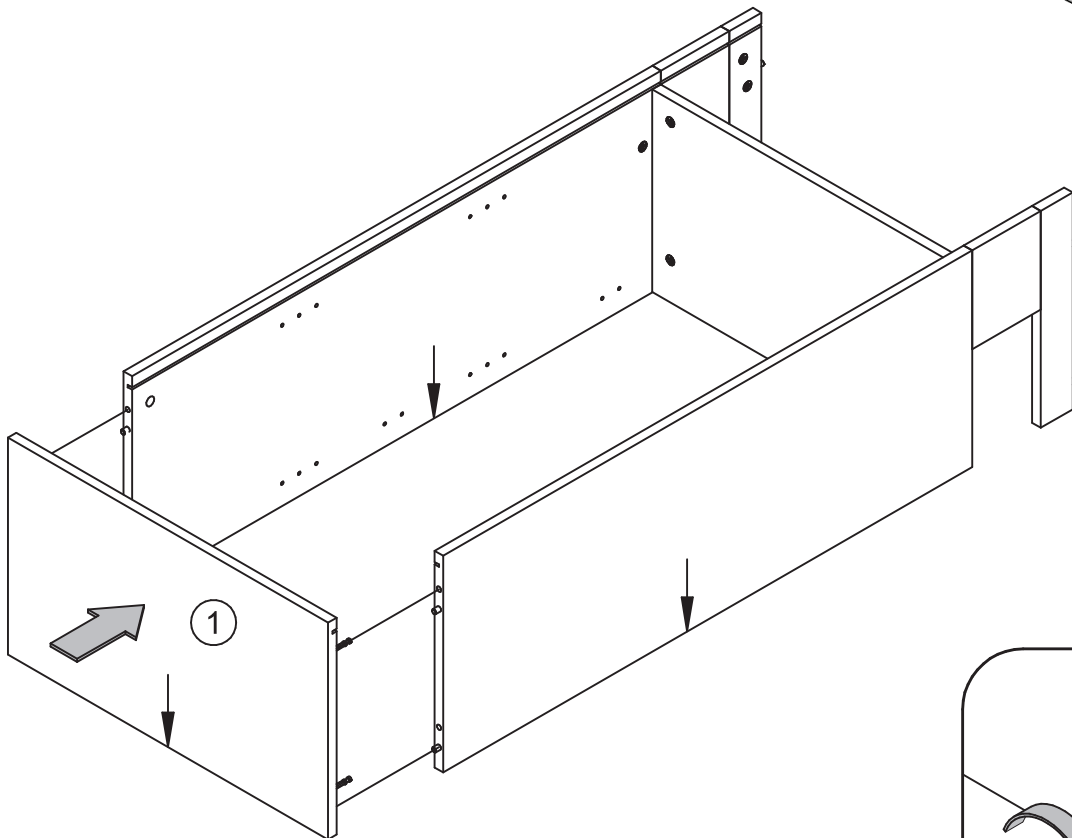
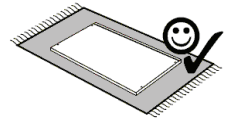

7.



8.

MM1039  Ø4x20 x8	BT50481  60x40x20 x4
---	---

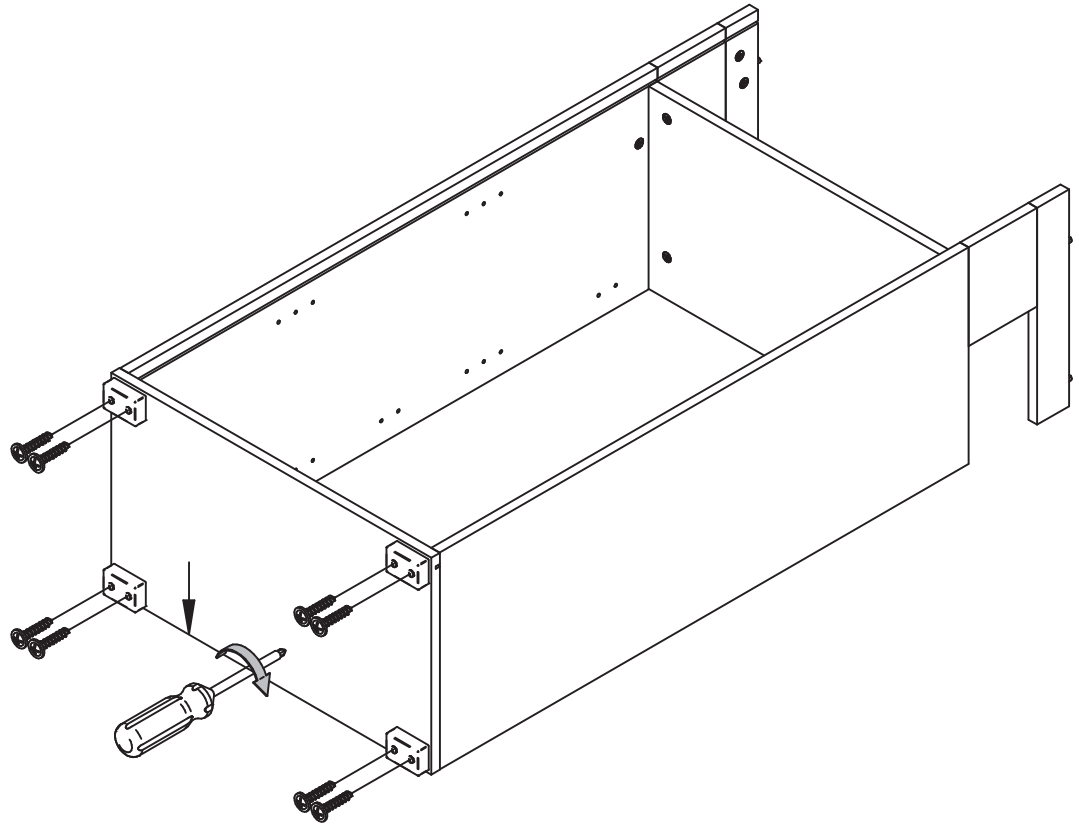
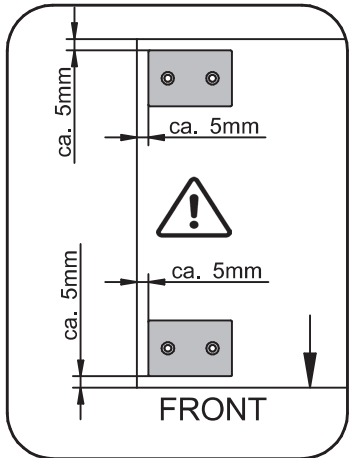
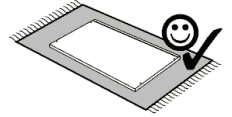

9.

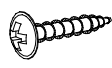
MM1017  4x16 x4
--

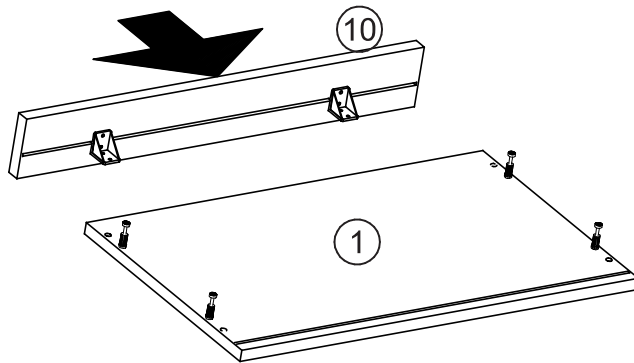
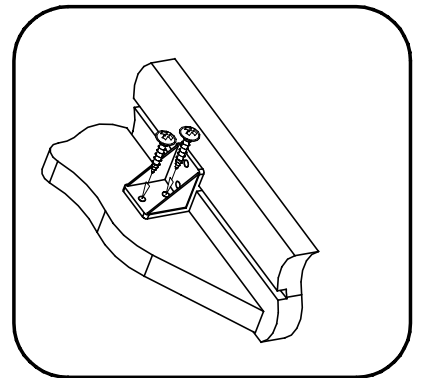

10.

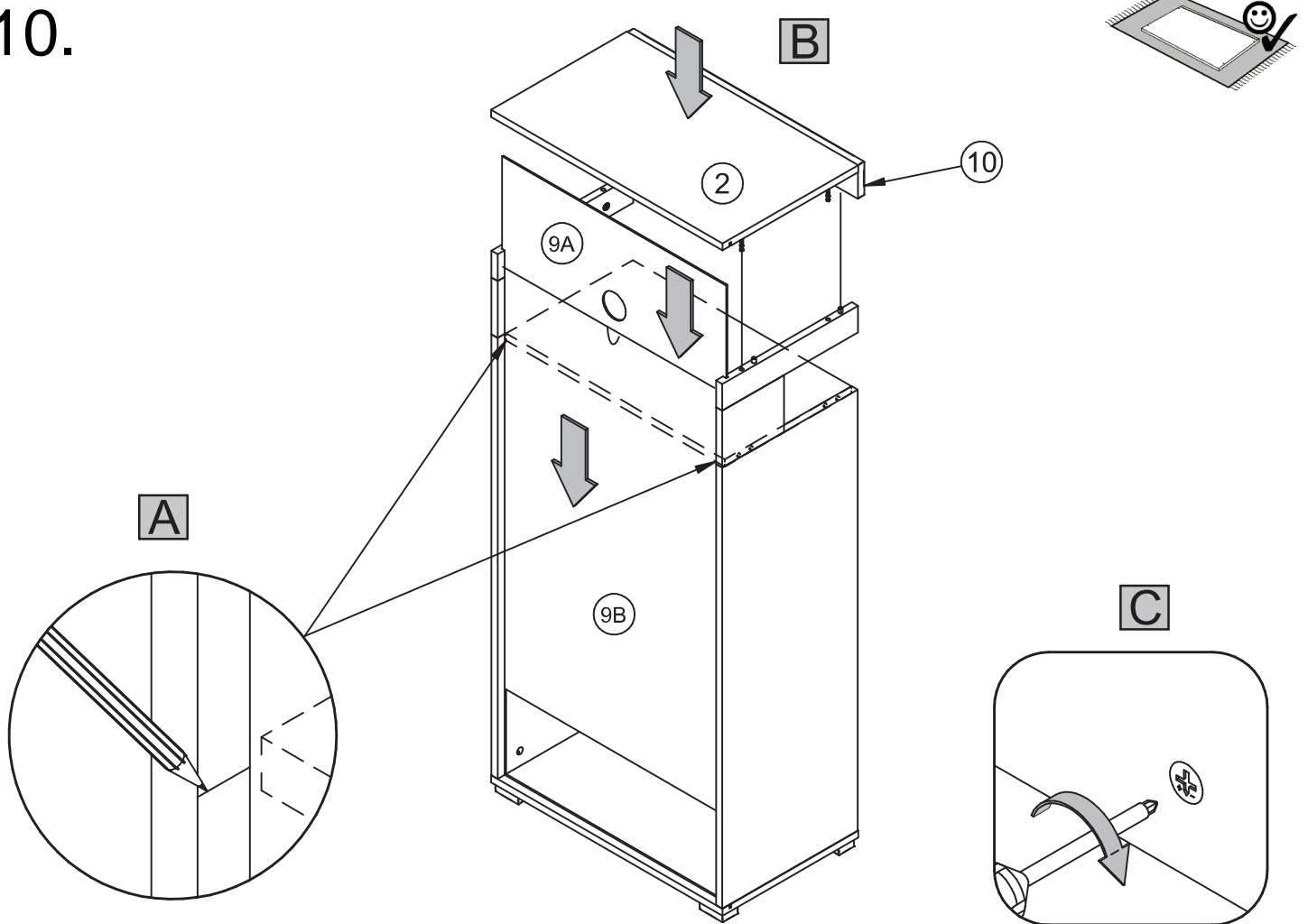

11.

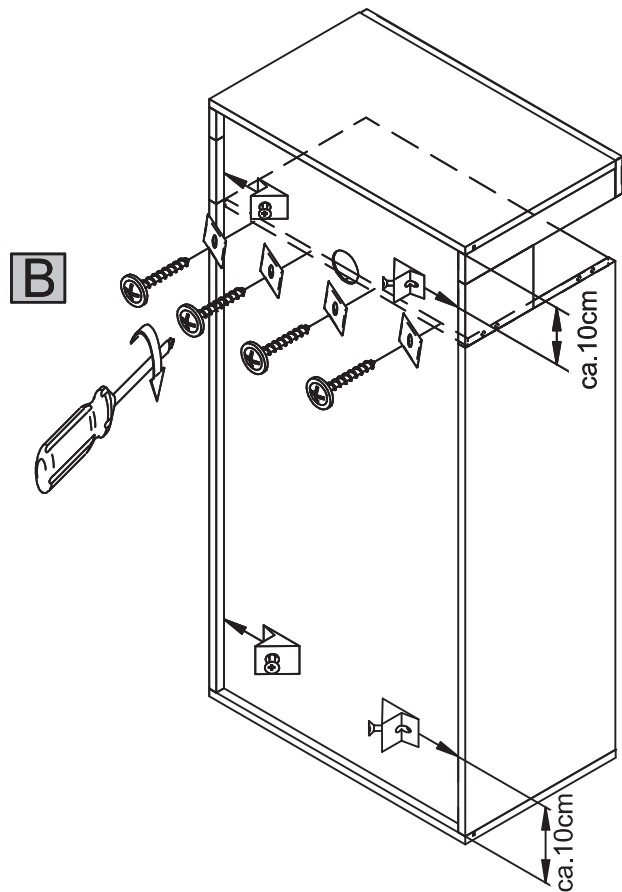
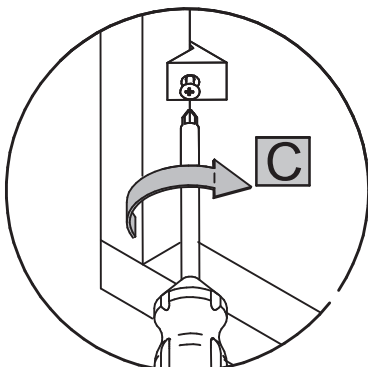
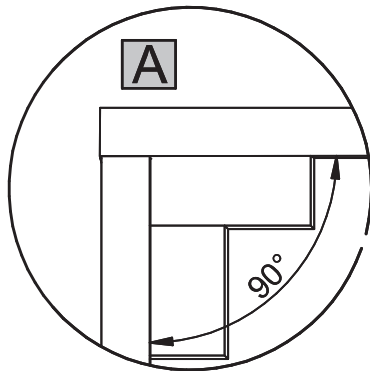
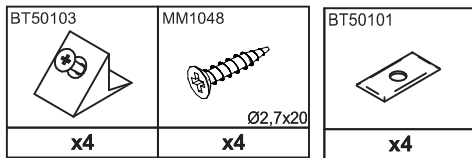

12.

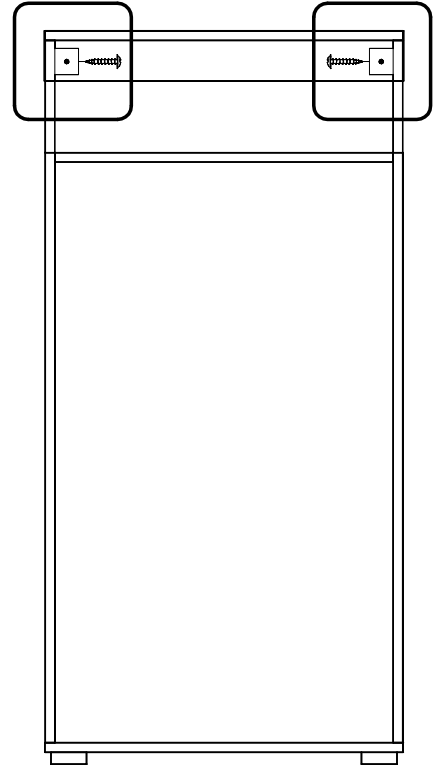
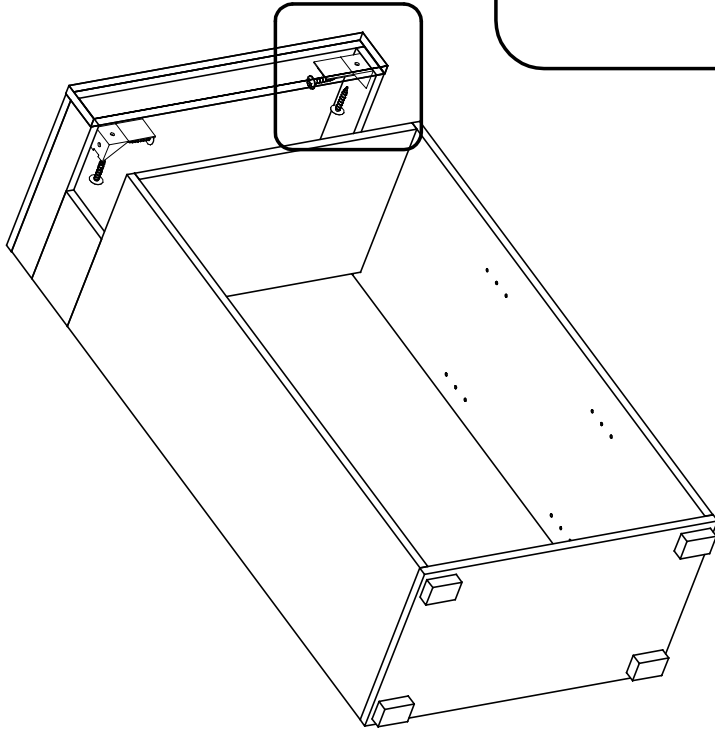
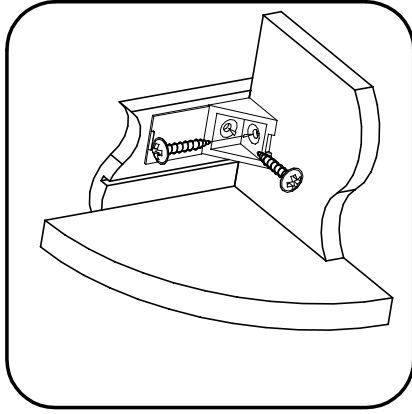
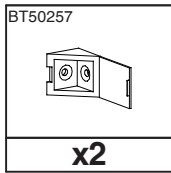
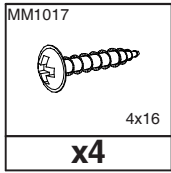

13.

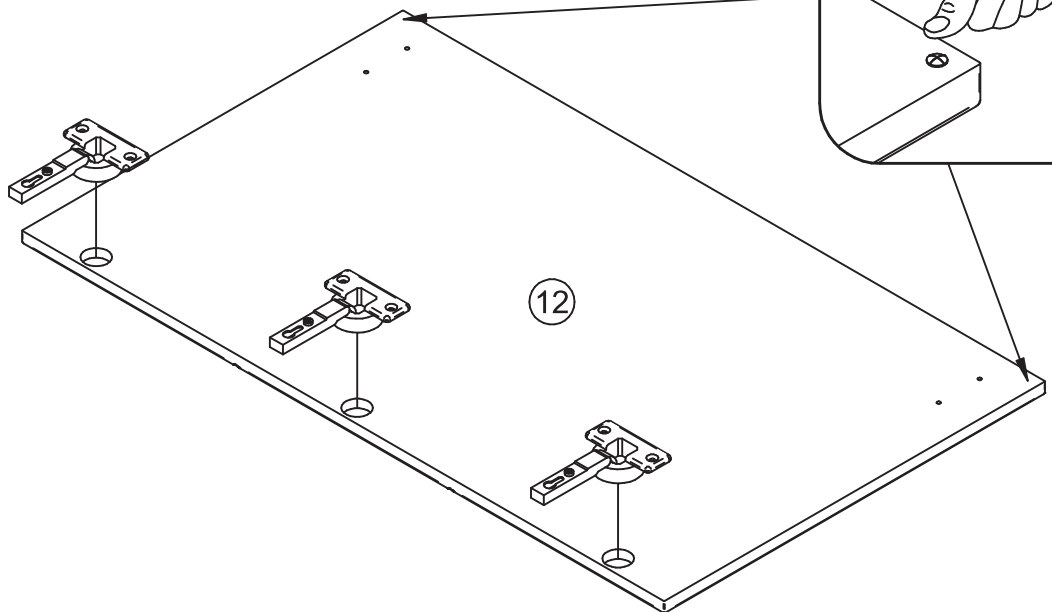
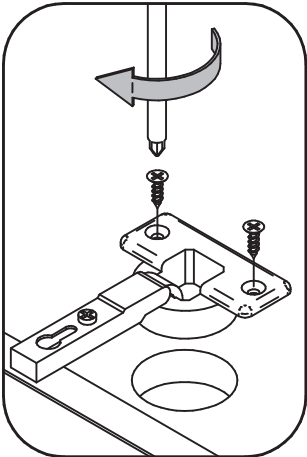
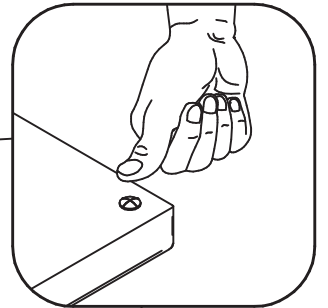
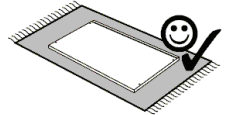
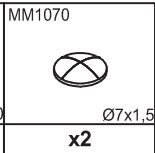
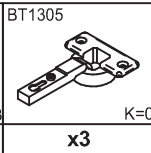
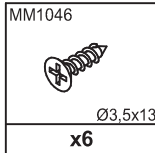

14.

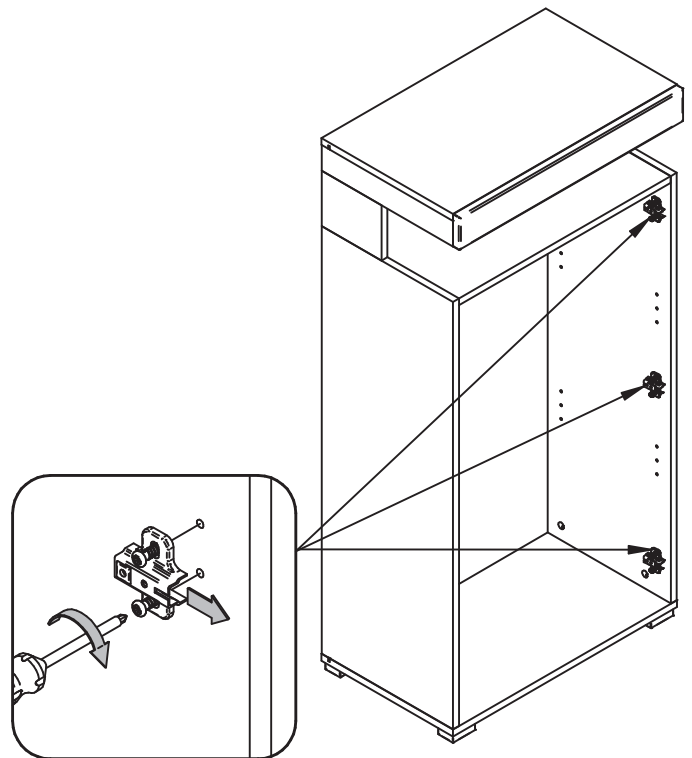
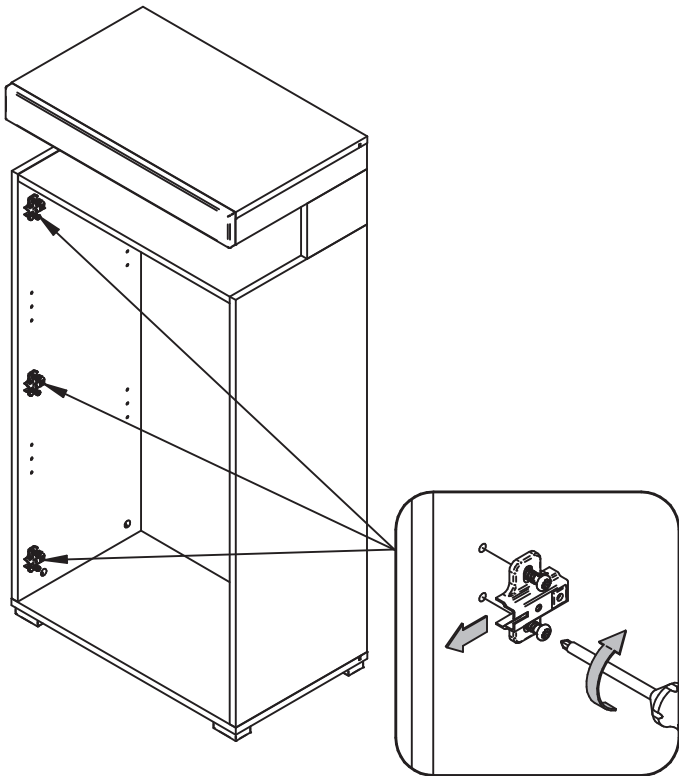
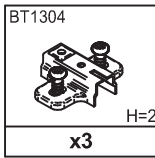

15.

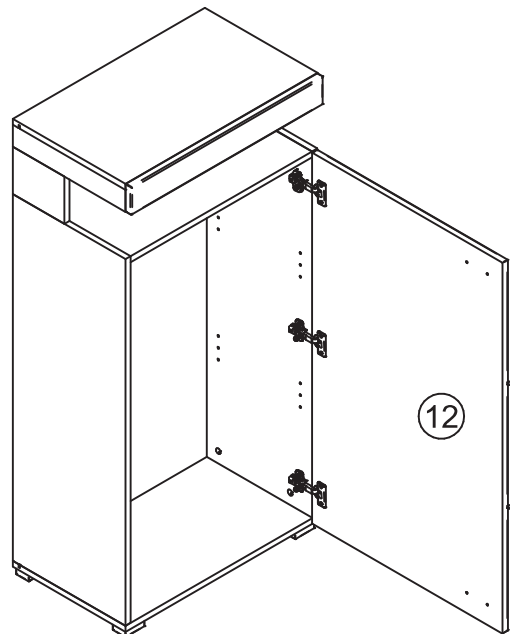
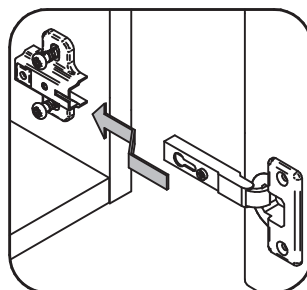
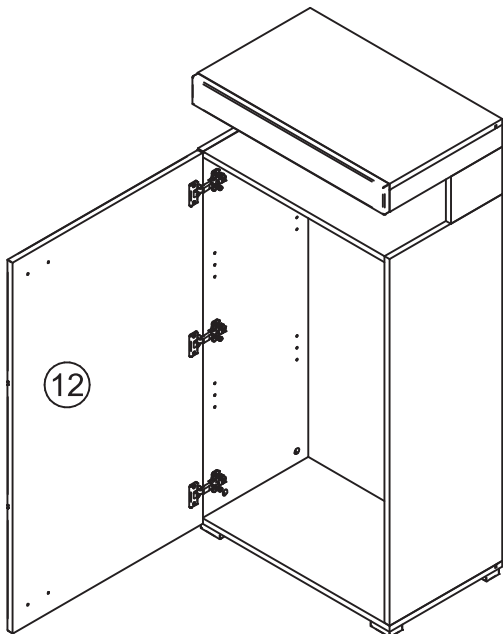
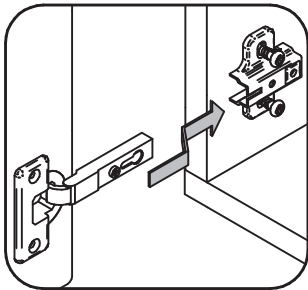

16.

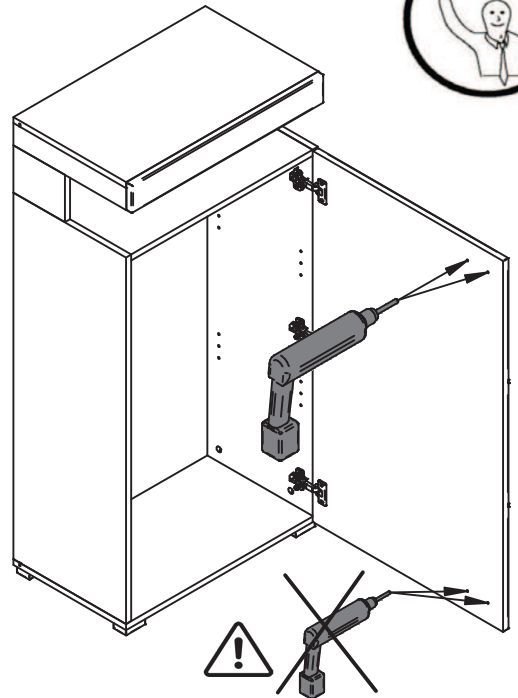
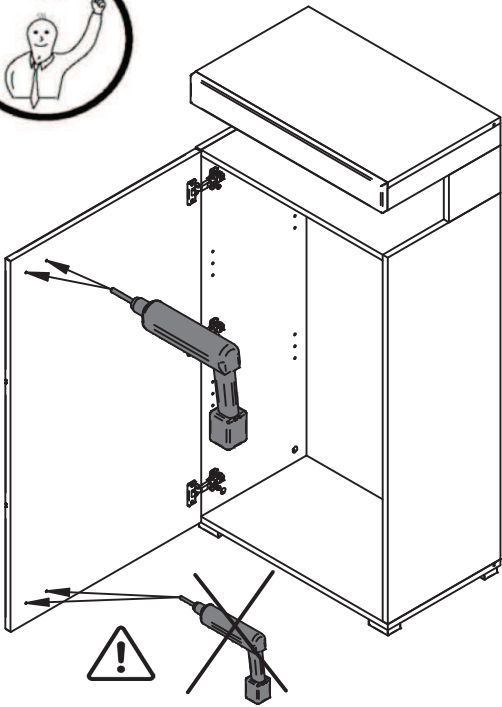
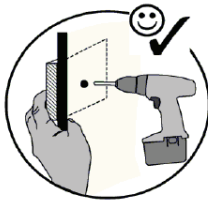
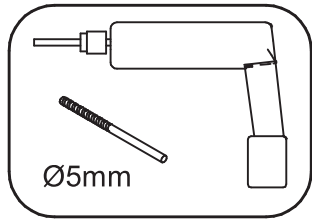

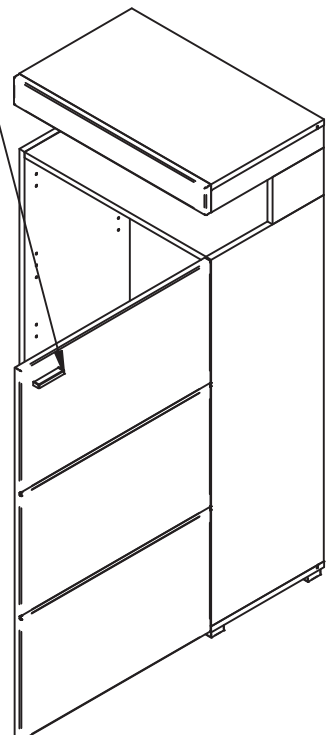
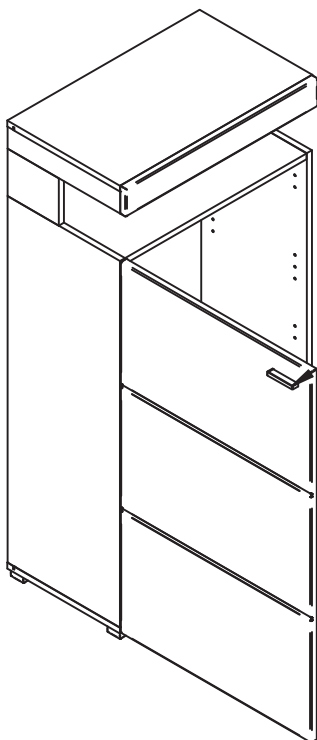
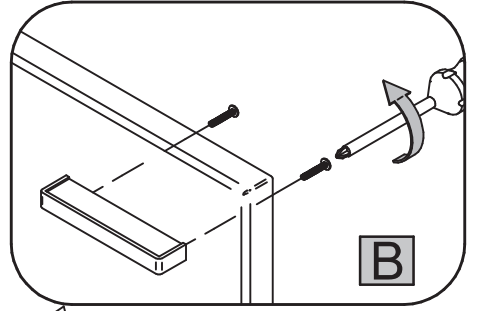
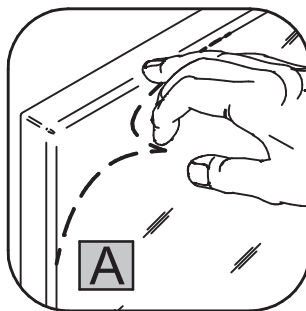

17.

BT50210	MM1010
BA=64	4x30
x1	x2

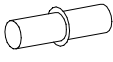

18.

BT1005.xx  x8	BT50162.xxx  x2	BT50244.xxx  Ø5 Ø20 x16
--	--	--

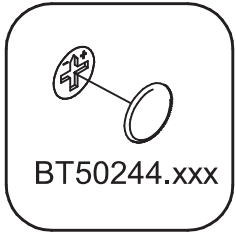
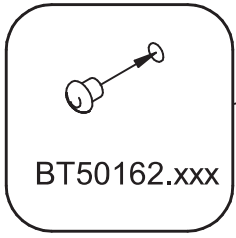
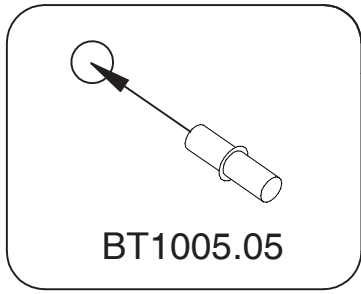

A

C

B

x2

11



A

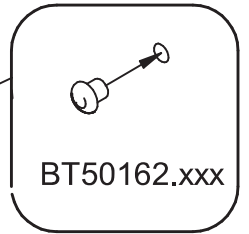
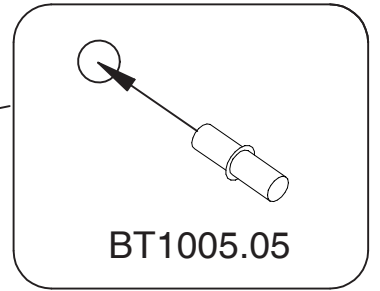

C



B

11

x2

19.

