

Assembly Instructions

⚠ Before you throw the package, please ensure that you have all the parts needed for the assembly.

⚠ **Hardware Note:**
1. Please **do not completely tighten** all the hardware, turn the bolts about **50%** by hand according to the AI step by step. Then adjust 4 legs when they are at same height, tighten all the bolts completely at last.

2. All the bolts should be assembled **vertically** to the holes.

⚠ **Spare parts** can be found in the hardware box if you do not have enough parts to assemble.

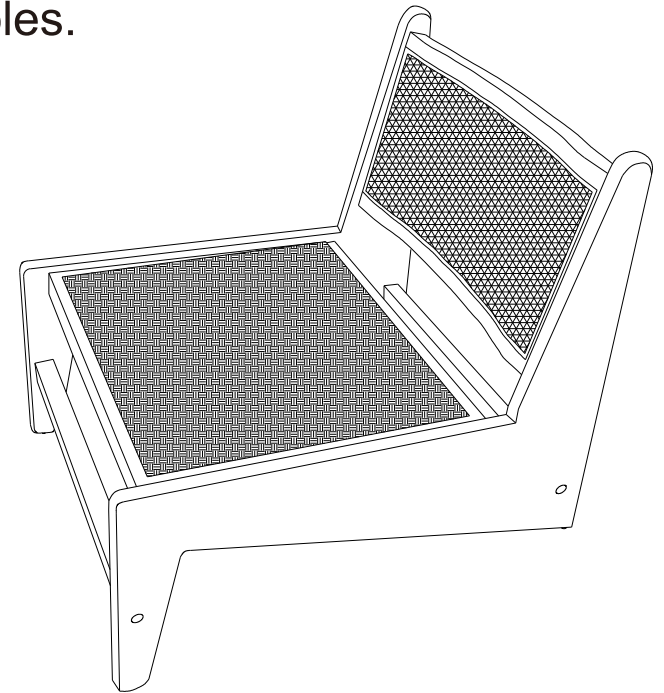

⚠ THIS INSTRUCTION BOOKLET CONTAINS IMPORTANT SAFETY INFORMATION. PLEASE READ AND KEEP FOR FUTURE REFERENCE.

Assembly Instructions

MADE IN CHINA

Parts and Hardware

Please check to make sure you have all parts and hardware before starting assembly process.

Ⓐ

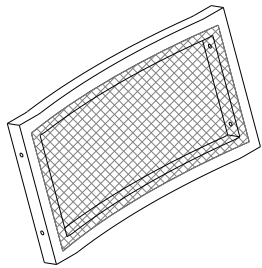

Back 1pc

Ⓑ

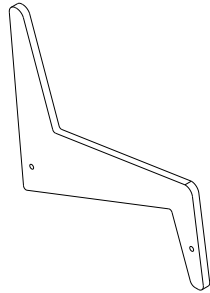

Left arm 1pc

Ⓒ

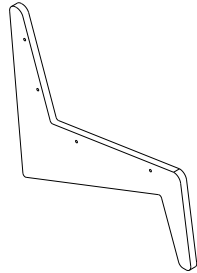

Right arm 1pc

Ⓓ

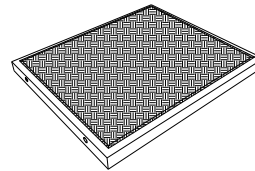

Seat 1pc

Ⓔ

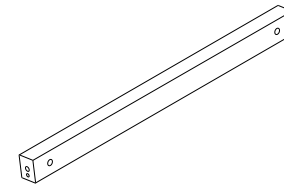

Wood connection 2pcs

①



Long bolts 8pcs

②



Short bolts 4pcs

③

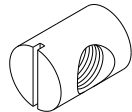

Nuts 4pcs

④

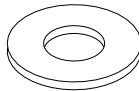

Flat washers 8pcs

⑤

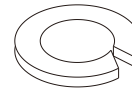

Spring washers 8pcs

⑥



Wrench 1pc

⑦



Wood pin 4pcs

Assembly Instructions

MADE IN CHINA

Assembly Instructions

Please read and understand all assembly instructions before beginning assembly process.
Do not tighten any single bolt until all bolts in holes on each step

Step 1. All the parts need to put on a soft and flat place. 

Step 2. Assemble back to arm.

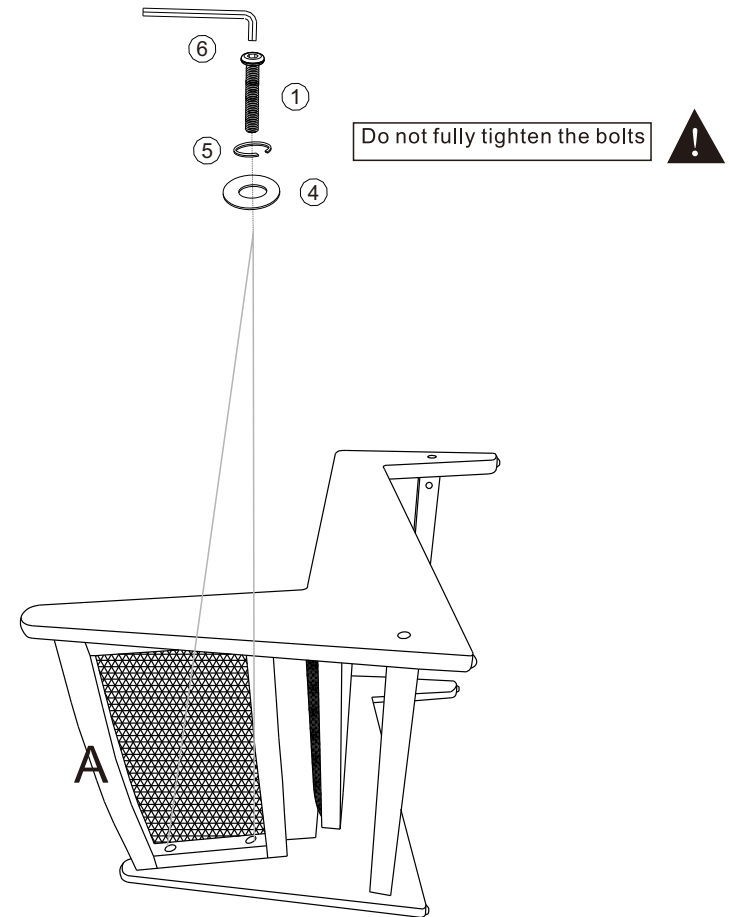
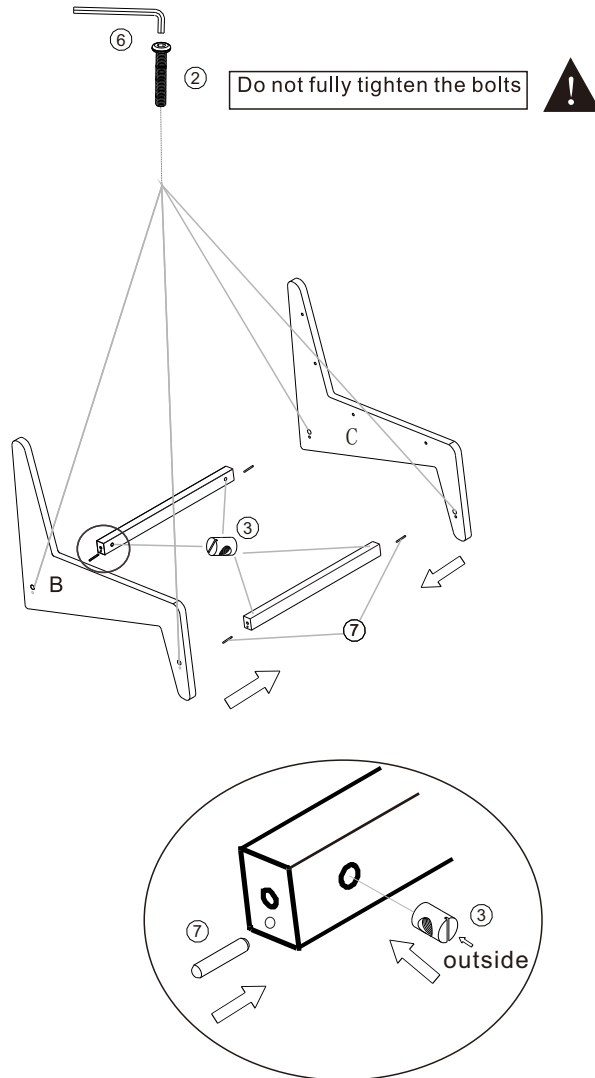

Assembly Instructions

MADE IN CHINA

Assembly Instructions

Please read and understand all assembly instructions before beginning assembly process.
Do not tighten any single bolt until all bolts in holes on each step

Step 3. Assemble seat to arms. Do not fully tighten the bolts until all of them are aligned to the holes then fully tighten them by the the short side of wrench.(include step 1 & 2)

