









Thank you for your purchase. Before discarding packaging material be sure you have located all the parts including the necessary hardware and tools listed on the instruction sheet below.

caution: Read before unpacking Assemble parts. "Sharp exposed staple tips can cause injury. For your Protection, please remove any exposed staples used in packaging.

Assembly Hardware List

Step 1 Number	Hardware Type	Description	Q' TY
A		φ1/4 X 1/2" FLAT ALLEN HEAD BOLT	8PCS
B		φ1/4 X 3/4" ALLEN HEAD BOLT	4PCS
C		φ1/4" SPRING WASHER	4PCS
D		φ1/4" *13 FLAT WASHER	4PCS
E		φ1/4" ALLEN WRENCH	1PC

Parts List

Step 1 Number	Type	Parts Description	Q' TY
1		Metal Leg	4PCS
2		Metal Shelf	1PC
3		Top	1PC

INSTRUCTIONS

Step 1: Please take out all parts from carton box.

Place all parts on soft surface.

Step 2: Assemble meta leg (1) and top (3) with bolt (A) by Allen Wrench (E).

Step 3: Loosely attach Metal Shelf (2) to Metal legs (1) with bolt (B), spring Washer (C) and flat washer (D) by Allen Wrench (E). Then tighten all bolts.

Step 4: Turn upright the table. See the illustration.

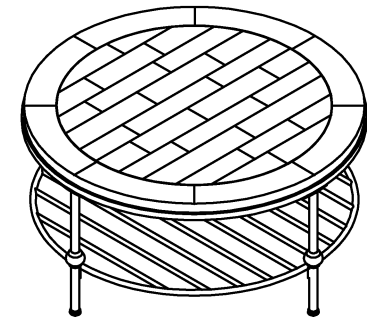
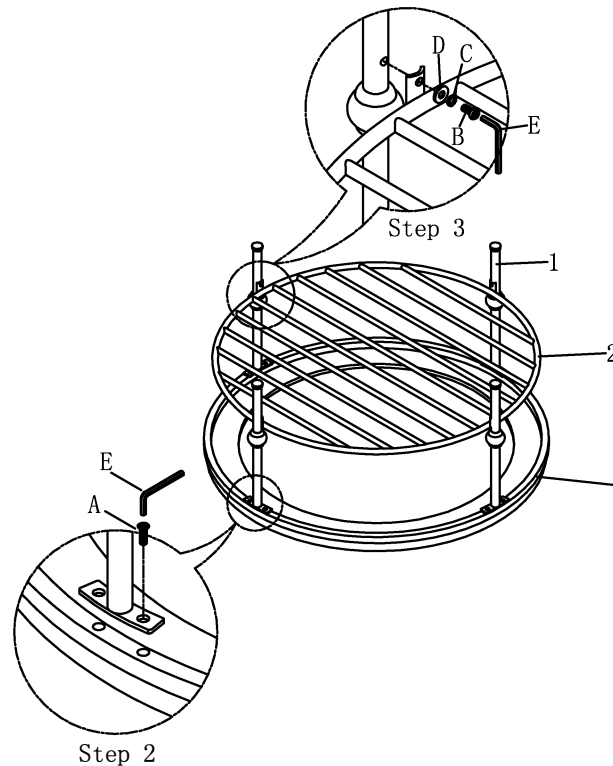

COCKTAIL
Step 4

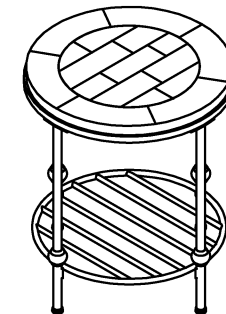

END TABLE
Step 4

Assemble is completed