

Product Introduction >>

Parameters and Specifications:

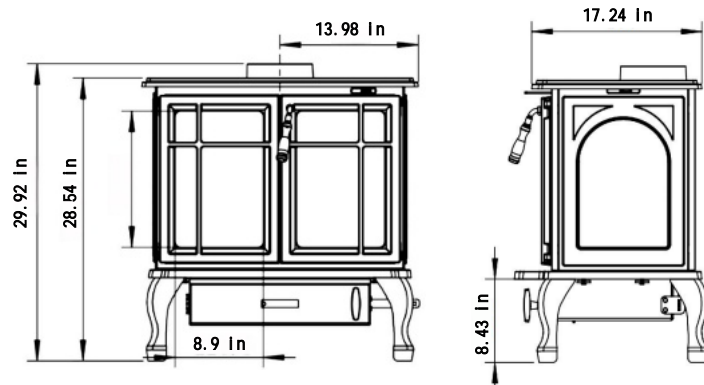

This data is derived from the test report or obtained under the specific conditions of the test:

Furnace specifications	Length: 540mm / Width: 330mm / Height: 350mm
Window specifications	Width: 225mm / Height: 350mm * 2 Side: Width: 130mm / Height: 320mm * 2
Diameter the smoke tube	152mm
Ventilation method	Top / Back
Material	Thickened cast iron
Weight	390 pounds
Combustion efficiency	86%
Door opening method	Double-page spread
Heating area	80

The diameter of the holes on the flue wall should be 1 to 2 millimeters larger.

Safety Notice >>

Before use, please read the instructions carefully and follow the precautions to ensure safety. Improper use may cause harm.

Warning

Fuel: Only use fully dried hardwood. Do not use coal.

Warning: Do not use flammable liquids or sprays to ignite.

Warning: Do not burn garbage in the furnace; otherwise, it will cause dangerous smoke and dust.

Warning: Do not burn wood that has been chemically treated or specially treated with preservatives.

Warning: Do not place any type of building panels, such as fiberboard or cement board, inside the stove.

Warning: Open the air vent before opening the window.

Protect yourself and your family from burns

When adding firewood, use heat-resistant gloves and do not throw the wood.

When in use, the outer surface of the fireplace will be at a relatively high temperature. Please provide a protective screen to prevent contact with the fireplace. To avoid burns.

Do not overburn (make the firebox too hot), as this will damage your fireplace.

Do not use exhaust fans or fans to enhance the air intake.

*A layer of ashes (1 inch thick) should always be retained at the bottom of the furnace and do not completely empty it.

*Do not use it when the glass is broken. If someone unfamiliar with the operation of the fireplace or if there is any damage to the fireplace, please stop using it.

*Burn wet wood that is heavily coated with grease. After the fireplace has been running for a long time, there may be deposits of wood oil in the exhaust system. Please clean them up promptly to avoid any dangers. The surface temperature of the fireplace is very high during use. Be cautious to prevent fires.

"Do not use exhaust fans or fans to enhance the air intake"

"Do not place flammable liquids or sprays near the fireplace."

"Do not add fuel into the furnace, as it may cause an explosion."

"Don't store the firewood very close to the stove."

Product Introduction >>

Before installing the fireplace, please check if the fireplace and its accessories are damaged, cracked or broken. Damaged parts can make the fireplace unsafe. The fireplace and the flue system should be installed in accordance with the installation standards and relevant requirements of building codes for the specific model of the fireplace. It

is recommended to have professional installers carry out the construction.

An appropriate flue system is of vital importance to the performance of a fireplace. The connection between the flue system and the fireplace must be sealed.

 <p>Fireplace tools (to retrieve the ash container and manipulate the fireplace lever)</p>		
<p>Use the diagram</p>		
 <p>Fixed furnace legs Backup screws</p>	 <p>Small wrench Fixed handle</p>	
		

Installation Preparation :

1. Take out the accessories and tools that come with the fireplace.
2. Prepare the chimney accessories of the specified size for the fireplace.
3. Transport to the installation location and place it on the floor tiles. If it is a wooden floor, to prevent sparks from splashing onto the ground, a brick or marble base can be placed underneath the fireplace.
4. For those that require embedding, the materials must be treated with fire-resistant materials that can withstand high temperatures.
6. Drill the installation holes according to the requirements of the fireplace style, such as

Requirements for chimney installation

1. Requirements for chimney height: It must extend to the required height above the roof to ensure sufficient suction. If the height is insufficient, the fireplace will not be able to obtain sufficient negative pressure, which may cause smoke to spill back into the room.
2. The height of the chimney should meet the following requirements: The minimum height of the chimney is 4 meters, and the height range is between 4 and 15 meters. The measurement is the vertical height from the neck of the furnace to the end of the chimney. The length of the horizontal pipe is recommended to be 30% of the vertical pipe.

Requirements for Fireplace Installation

1. Do not place the fireplace in a location where people frequently pass by. There should be no flammable or explosive items around the fireplace. The recommended distance between the fireplace and the wall is 15 inches. If the back of the fireplace is made of wood or other flammable materials, thermal insulation measures should be taken between the fireplace and the wall.
2. If the fireplace is to be installed on a carpet, wooden floor or other flammable materials, a 10-millimeter thick fire-resistant material pad (to protect the floor) must be placed beneath the stove, and it must be positioned on a solid and flat horizontal surface.

Pipe Installation method

1. Vertical installation of indoor walls: It is recommended to use direct exhaust smoke pipes for installation. This can better utilize the heat generated by the smoke pipes. However, waterproof measures need to be taken.
2. Installation of internal walls in horizontal direction;90-degree elbows running horizontally: The horizontal distance should not exceed 1 meter. In special cases , for special designs, the horizontal distance should also not exceed 3 meters. It's advisable to add a tee connection and a reserved maintenance opening for future maintenance purposes.

For every 1-meter increase in the horizontal distance, the vertical distance should also increase by 1 meter. Such an installation will ensure more complete combustion

No flammable items are allowed to be used for decoration around all chimneys.

Chimney outlet must not be lower than the minimum height of the nearby buildings.

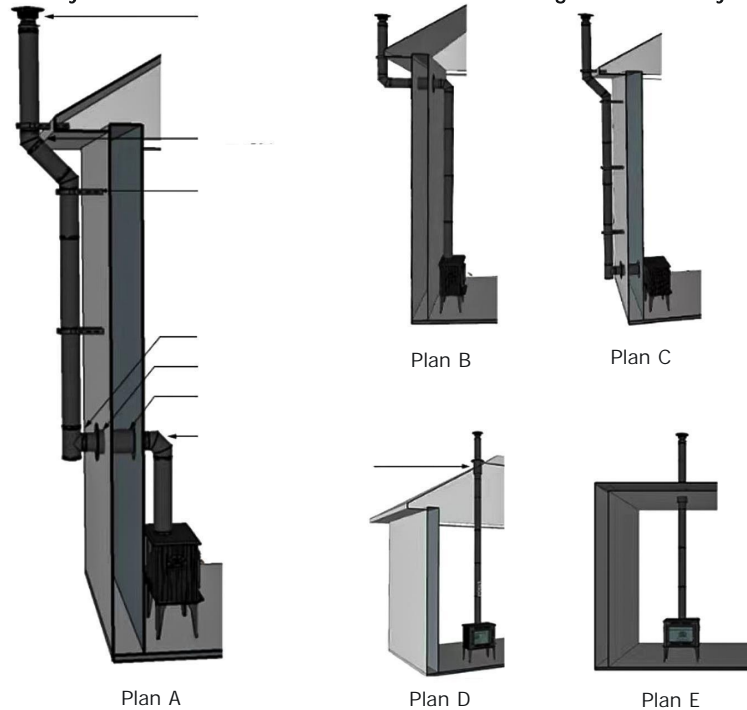

Note:Height requirements for the smoke tube

The total length of the vertical smoke pipes minus the total length of the horizontal smoke pipes is greater than or equal to 4 meters.

The hat was higher than the roof edge.

Usage instructions

Before using the fireplace, please read this chapter carefully.

Each component of the fireplace is coated with a high-quality finish to protect it and make the fireplace look more beautiful. These coatings will harden during use. The hardening process is as follows: burn a small fire three times to allow it to harden slowly.

1. The first solidification flame is only ignited and maintained for 30 minutes. The window door is slightly opened to prevent the sealing rope from getting stuck.
2. After cooling, repeat this process.
3. The third fixation process involves maintaining a normal flame for at least 45 minutes.

During the curing process, some smoke will be emitted from the surface and some odors will be detected. This is a normal phenomenon. It is recommended to carry out the curing process outdoors or with the windows open. In colder conditions, or when the fireplace uses a fan, the curing process may take slightly longer.

Operation method for wind doors

(Operate the air shutter. The adjustment of the air shutter can control the size of the flame)

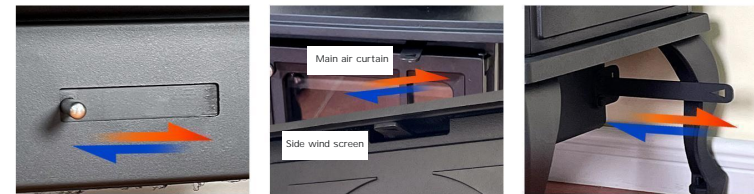

Promote combustion system (single intake)

Fan air system (secondary air intake)

Secondary combustion system (three-stage intake)

Promote combustion system : Swipe right to open, swipe left to close. It helps the firewood ignite quickly. It is mainly used as a fuel booster. It can control the burning speed of the wood. It is not recommended to keep it open for a long time!

Fan air system : Fan curtain system - Swipe right to open, swipe left to close . It can create a wind curtain between the glass and the flame, preventing dust from adhering to the glass, thus keeping the glass clean all the time!

Secondary combustion system - Pull outward to open, push inward to close. This provides sufficient oxygen to the furnace. When the furnace temperature reaches 600 , it can burn the high-temperature gases in the furnace, doubling the heat output, reducing emissions, and saving more fuel!

Usage instructions

Regarding the low-oxygen combustion - by only opening the secondary or tertiary intake, you can achieve low-temperature combustion or extend the combustion time.

Regarding medium-fire combustion - with both secondary and tertiary air intake valves open simultaneously, this is the optimal setting for normal operation.

Regarding the fire burning - all three air intakes are fully open. During the ignition process and for at least 30 minutes after ignition, as well as for at least 30 minutes after refueling again.

Light the fire

-- When wood is exposed to flames at a temperature above 600 °C, its combustion efficiency is at its peak. The following methods will help you quickly bring the fireplace to the appropriate temperature.

--All three air intakes are fully open and the air vents have been adjusted to the maximum.

--Put 3 to 5 ignited wax blocks into the fireplace, then place some kindling sticks, and arrange some small pieces of wood in a cross pattern on the kindling sticks.

--Use the igniter to light it.

--Continue to add small pieces of wood until a hot carbon layer is formed.

--Add 2-3 pieces of wood with a diameter of about 8-10 centimeters. Placing them in front and back will make the fire burn more vigorously.

--Adding firewood will weaken the flame. Therefore, after you add the firewood, please adjust the air vent to medium or high heat and keep it for 30 minutes to allow the flame to return to normal.

Attention

The firewood is stacked from front to back. Space should be left between the pieces to allow air to flow through. Except during the ignition stage and the stage of adding wood, the window door should remain closed at all times.

Burning all night

The large logs are the best fuel for a full night's burning. Before adding this kind of wood, make sure that the hot carbon layer in the furnace has formed and the flame temperature is sufficient. After adding the wood, close the furnace door and keep the fire at high intensity for about 30 minutes or ensure that the new wood has been ignited. The air vent should be adjusted to low heat or closed.

How to restore the flame after burning throughout the night

1. Open all the windshields and adjust them to the maximum position.
2. Use a fire rake to evenly distribute the charcoal fire.
3. Add fire starters and small pieces of wood.
4. Once the fire is established, add large pieces of wood.

07/08

Clear away the ashes

When the ash layer reaches the bottom of the furnace opening, it's time to clean the ashes. Remember to do this only after the furnace has completely cooled down.

1. Push aside the large chunks of coke. These will burn again during the next ignition, so they must not be wasted.

2. Pull the cleaning lever to easily let the ashes fall into the built-in ash container. It's simple and convenient.

3. The site for dumping the ashes should be an area where there are no combustible materials.

A small amount of ashes should be left in the furnace to provide a thermal insulation layer for the next combustion. Use a rake to spread them evenly.

Burning wood requires

Hardwood is one of the best fuel sources for fireplaces. The requirements for firewood for a fireplace are: dry and free of grease.

Hardwood is denser and burns for a longer time. The burning process releases heat slowly, ensuring stable indoor temperature and flame. The smoke and dust produced during the burning process are also less (such as beechwood, oak, birch, elm, pecan, maple, locust, and ash are all excellent firewood.)

Wood that is not suitable for burning in a fireplace

1. Wet or rotten wood (with extremely low thermal efficiency, producing wood distillate oil and posing fire hazards).
2. Trees with peculiar odors, such as the cypress tree (the gases released during combustion are harmful to the human body).
3. Woods with abundant resin, such as pine, cypress, and peach trees (after burning, they produce oily substances that adhere to the inner walls of the combustion system, making it difficult to clean and prone to causing fires).
4. Sawdust or wood shavings (can be used as a kind of ignition material in small quantities. They should not be used as the main fuel as they burn very quickly and intensely, which can cause the fireplace to overheat and damage the fireplace).
5. The plates that have been compressed under high pressure (the combustion is intense, which can easily cause the furnace to overheat and damage the furnace).
6. Wood coated with asphalt or paint (which releases toxic gases when burned)
7. The trays that have been fumigated (will release toxic gases during combustion)
8. Plywood or other boards containing glue (which release toxic gases when burned).
9. Railway sleepers (which release toxic gases when burned).
11. Wood that has been treated chemically (which releases toxic gases when burned).

07/08

Maintenance and upkeep

⚠ Attention!

The refractory bricks in the furnace must be handled with care. Do not throw wooden blocks into the furnace. This could cause the refractory bricks to break!

Cleaning

Fireplace surface: For general dust, use a slightly dry cloth to gently wipe it. If there are stubborn stains that are difficult to clean, use a soft damp cloth to wipe. Then, gently dry it with a dry soft cloth. Do not use solvents or cleaning agents, as they may damage the wall. (In coastal cities, it needs to be cleaned once a week to prevent salt erosion.)

Fire glass: Sometimes black deposits accumulate inside the glass. To remove these deposits, use a damp cloth moistened with water and cleaning agent to gently wipe with some furnace ashes, then wipe with a damp cloth, and finally dry with a dry cloth.

Daily maintenance

It is carried out at the beginning of the heating season and is conducted every 8 weeks throughout the entire heating season.

Check and briefly clean the interior of the fireplace.

At the end of the heating season

1. Check the door glass
2. Check the sealing rope and the sealing parts
3. Inspect the combustion chamber
4. Inspect the fire-resistant bricks
5. Check if the air vent moves smoothly

The accumulation of tree oils

When the temperature inside the fireplace remains consistently below the normal combustion temperature (for example, due to the use of dry, un-dried wood), a high amount of normal smoke will be produced. This smoke will condense on the inner walls of the chimney. As a result, black, asphalt-like deposits will form. It is normal to have a very thin layer in the flue, but it should not exceed 3MM thick.

1. If the wood oil layer is very thick, it will impede the flow of smoke and result in insufficient suction force, and even cause the smoke to overflow and enter the room.
2. The lignin oil is flammable, and chimney fires are prone to occur.

To prevent chimney fires caused by the accumulation of resin oil, please use dry wood with a lower oil content. When using, adjust the air vent to the medium or high position. To remove the accumulated resin oil, remove the fire shield and chimney cover, and clean the chimney with a chimney brush. If a chimney fire occurs, do not panic. Your chimney system itself can withstand high temperatures. Immediately close the air vent. Do not open the furnace door window. When the chimney fire is over, please have professionals inspect it.