

Product manual
 Gebrauchsanweisung
 Manuel du produit
 Manual del producto
 Manuale del prodotto

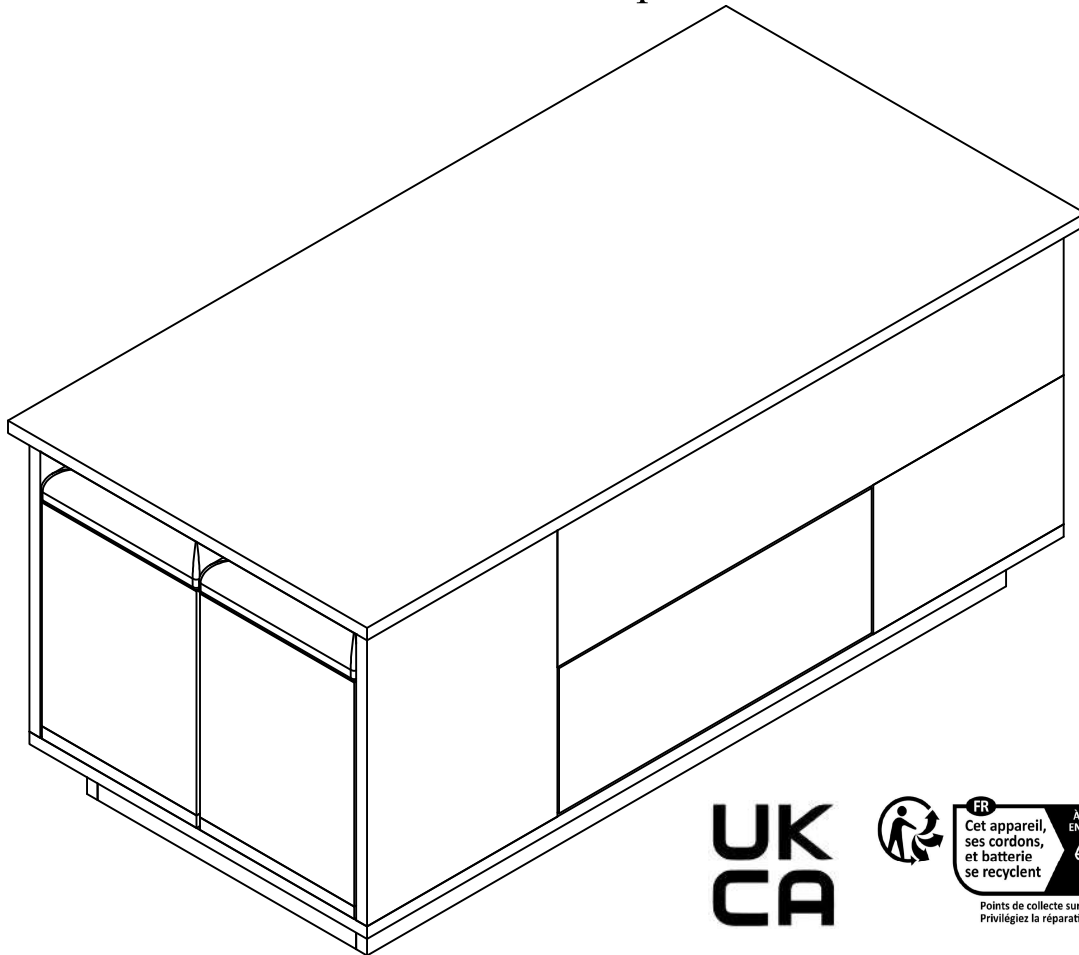

**UK
CA**



FR
 Cet appareil,
 ses cordons,
 et batterie
 se recyclent

À DÉPOSER
 EN MAGASIN

OU

À DÉPOSER
 EN DÉCHÈTERIE

Points de collecte sur www.quefairedelesdechets.fr
 Privilégiez la réparation ou le don de votre appareil !

EN:Our product will be delivered to you in 2 packages.The delivery times of these 2 packages may differ,please be patient and thank you for your understanding

FR:Notre produit vous sera livré en 2 colis.Les delais de livraison de ces 2 colis peuvent différer, soyez patient et merci de votre compréhension.

DE:Unser Produkt wird Ihnen in 2 Paketen geliefert.Die Lieferzeiten dieser 2

Paketekönnenabweichen,bitte haben Sie etwas Geduld und vielen Dank für Ihr Verständnis

IT:I nostri prodotti vengono trasportati in due pacchetti. I tempi di consegna dei due pacchetti sono diversi abbiate pazienza e vi ringrazio per la vostra comprensione.

ES:Nuestro producto se entrega en dos paquetes. El tiempo de entrega de estos dos paquetes es diferente. Por favor sea paciente. Gracias por su comprensión.



2PERS

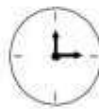

45 MIN

Tool Required Not Provided

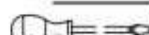



[DE]

Warnung: Lesen Sie diese Anleitung vor dem Zusammenbau bitte vollständig durch. Überprüfen Sie, ob Sie alle auf den Seiten aufgeführten Komponenten und Werkzeuge haben. Bewahren Sie die Anleitung zum späteren Nachschlagen auf. Teile des Zusammenbaus lassen sich mit 2 Personen leichter durchführen. Suchen Sie bei Bedarf professionelle Hilfe.

Warnung: Legen Sie alle Teile auf eine ebene Fläche. Legen Sie eine weiche Decke oder Ähnliches darunter, um sie vor Kratzern oder Flecken zu schützen. Vermeiden Sie es, Komponenten über den Boden zu ziehen oder zu schieben.

Warnung: Überprüfen Sie regelmäßig alle Beschläge und Befestigungen, um sicherzustellen, dass sie sicher sind und um Unfälle zu vermeiden. Wenn Teile fehlen, kaputt, beschädigt oder abgenutzt sind, verwenden Sie das Produkt nicht weiter, bis es mit vom Hersteller autorisierten Teilen repariert wurde.

Warnung: Lassen Sie Kinder nicht auf die Möbel klettern, da dies zum Umkippen und zu schweren Verletzungen führen kann. Bauen Sie die Möbel außerhalb der Reichweite von Kindern zusammen.

Warnung: Stellen Sie die Möbel nicht in die Nähe von Feuerquellen oder heißen Gegenständen, um Brandgefahr zu vermeiden.

Warnung: Reinigen Sie die Möbel mit einem feuchten Tuch oder Alkohol. Verwenden Sie keine Reinigungsmittel mit ätzenden Chemikalien.

[EN]

Warning: Please read these instructions fully before starting assembly. Check you have all the components and tools listed on pages. Keep the instructions for later reference. Parts of the assembly will be easier with 2 people. Seek professional assistance if necessary.

Warning: Please place all parts on a flat surface. Place a soft blanket or similar underneath to protect against scratches or stains. Avoid dragging or sliding components across the floor.

Warning: Regularly check all fittings and fastenings to ensure they are secure and to prevent accidents. If any parts are missing, broken, damaged, or worn, discontinue use of the product until repairs have been made using factory authorized parts.

Warning: Do not allow children to climb on the furniture as this may result in tipping and serious personal injury. Assemble the furniture away from the reach of children.

Warning: Do not place furniture close to fire sources or high-temperature objects to avoid the risk of fire. Do not place furniture in damp environments to prevent material damage.

Warning: Clean furniture with a damp cloth or alcohol, avoid using cleaning agents containing corrosive chemicals.

[FR]

Avertissement : Veuillez lire attentivement ces instructions avant de commencer l'assemblage. Vérifiez que vous disposez de tous les composants et outils répertoriés sur les pages. Conservez les instructions pour référence ultérieure. Certaines parties de l'assemblage seront plus faciles à 2 personnes. Demandez l'aide d'un professionnel si nécessaire.

Avertissement : Veuillez placer toutes les pièces sur une surface plane. Placez une couverture douce ou similaire en dessous pour les protéger des rayures ou des taches. Évitez de faire glisser les composants sur le sol.

Avertissement : Vérifiez régulièrement tous les raccords et fixations pour vous assurer qu'ils sont bien fixés et pour éviter les accidents. Si des pièces manquent, sont cassées, endommagées ou usées, cessez d'utiliser le produit jusqu'à ce que des réparations aient été effectuées à l'aide de pièces autorisées par l'usine.

Avertissement : Ne laissez pas les enfants grimper sur les meubles car cela pourrait entraîner un basculement et des blessures graves. Assemblez les meubles hors de portée des enfants.

Avertissement : Ne placez pas les meubles à proximité de sources de feu ou d'objets à haute température pour éviter tout risque d'incendie.

Avertissement : Nettoyez les meubles avec un chiffon humide ou de l'alcool, évitez d'utiliser des produits de nettoyage contenant des produits chimiques corrosifs.

[IT]

Attenzione: leggere attentamente queste istruzioni prima di iniziare il montaggio. Verificare di avere tutti i componenti e gli strumenti elencati nelle pagine. Conservare le istruzioni per riferimento futuro. Alcune parti del montaggio saranno più facili con 2 persone. Se necessario, chiedere assistenza professionale.

Attenzione: posizionare tutte le parti su una superficie piana. Posizionare una coperta morbida o simile sotto per proteggere da graffi o macchie. Evitare di trascinare o far scivolare i componenti sul pavimento.

Attenzione: controllare regolarmente tutti i raccordi e i dispositivi di fissaggio per assicurarsi che siano sicuri e per prevenire incidenti. Se alcune parti sono mancanti, rotte, danneggiate o usurate, interrompere l'uso del prodotto fino a quando non siano state eseguite le riparazioni utilizzando parti autorizzate dalla fabbrica.

Attenzione: non consentire ai bambini di arrampicarsi sui mobili poiché ciò potrebbe causare ribaltamenti e gravi lesioni personali. Montare i mobili lontano dalla portata dei bambini.

Attenzione: non posizionare i mobili vicino a fonti di fuoco o oggetti ad alta temperatura per evitare il rischio di incendio

Attenzione: pulire i mobili con un panno umido o alcol, evitare di utilizzare detergenti contenenti sostanze chimiche corrosive.

[ES]

Advertencia: Lea estas instrucciones completamente antes de comenzar el montaje. Compruebe que tiene todos los componentes y herramientas que se enumeran en las páginas. Conserve las instrucciones para consultarlas más adelante. El montaje de algunas partes será más sencillo con 2 personas. Busque ayuda profesional si es necesario.

Advertencia: Coloque todas las piezas sobre una superficie plana. Coloque una manta suave o algo similar debajo para protegerlas de rayones o manchas. Evite arrastrar o deslizar los componentes por el piso.





Advertencia: Verifique regularmente todos los accesorios y fijaciones para asegurarse de que estén seguros y evitar accidentes. Si falta alguna pieza, está rota, dañada o desgastada, deje de usar el producto hasta que se hayan realizado las reparaciones con piezas autorizadas de fábrica.



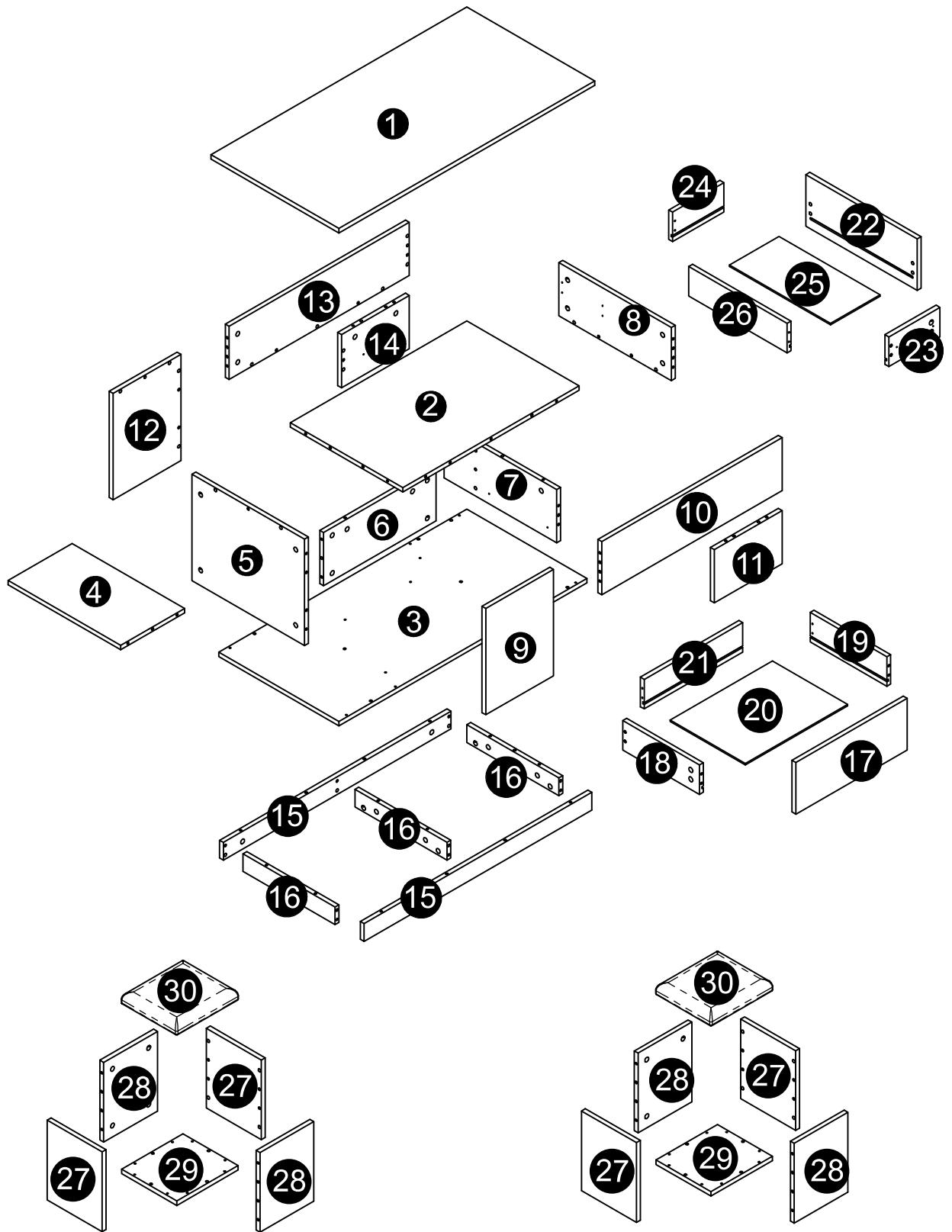

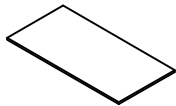
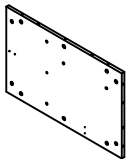
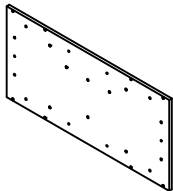
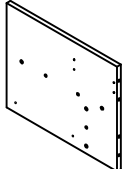
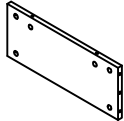
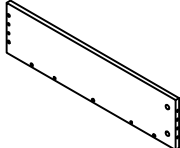

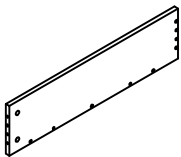
Advertencia: No permita que los niños se suban a los muebles, ya que esto puede provocar que se vuelquen y lesiones personales graves. Monte los muebles fuera del alcance de los niños.

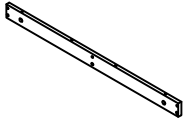
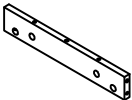

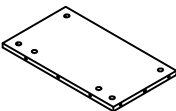
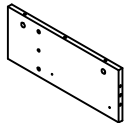
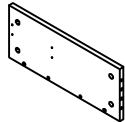
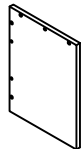
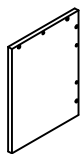
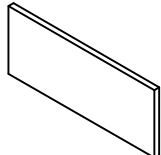
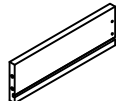
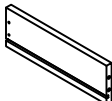
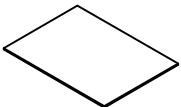

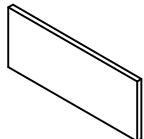

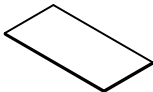

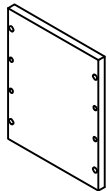
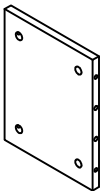
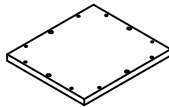
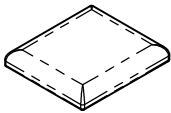

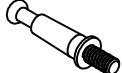

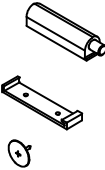
Advertencia: No coloque los muebles cerca de fuentes de fuego u objetos de alta temperatura para evitar el riesgo de incendio.

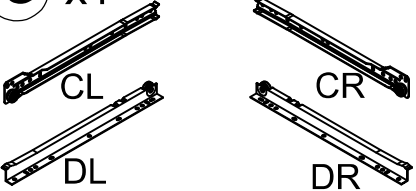
Advertencia: Limpie los muebles con un paño húmedo o alcohol, evite usar agentes de limpieza que contengan químicos corrosivos.

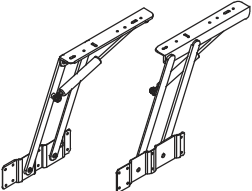

						
① x1	② x1	③ x1	⑤ x1	⑥ x1	⑩ x1	⑪ x1
						
⑬ x1	⑭ x1	⑮ x2	⑯ x3			

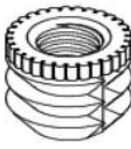
						
④ x1	⑦ x1	⑧ x1	⑨ x1	⑫ x1	⑰ x1	⑱ x1
						
⑲ x1	⑳ x1	㉑ x1	㉒ x1	㉓ x1	㉔ x1	㉕ x1
						
⑳ x1	㉗ x4	㉘ x4	㉙ x2	㉚ x2		

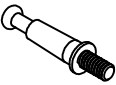
<p>A x77</p> 	<p>B x62</p> 	<p>C x84</p> 	<p>D x 2</p> 	<p>E x22</p> 	<p>F x44</p> 
<p>φ8*40</p>				<p>φ3.5*35</p>	<p>φ3.5*14</p>
<p>G x1</p> 	<p>H x18</p> 	<p>I x1</p>  <p>Left Side Linke Seite Côté Gauche Lado Izquierdo Lato Sinistro</p> <p>Right Side Rechte Seite Côté Droit Lado Derecho Lato Destro</p>			
<p>300mm</p>					
<p>J x1</p> 		<p>K x70</p> 	<p>L x1</p> 		
<p>200mm</p>			<p>2800mm</p>		
<p>M x16</p> 	<p>N x5</p> 	<p>O x1</p> 	<p>P x16</p> 		
<p>φ3.5*30</p>					

EN:If you find that the white glue particles on the board are missing, please press part N into the board.
 DE:Sollten Sie feststellen, dass die weißen Gumpartikel auf der Platine fehlen, drücken Sie bitte Teil N in die Platine.
 FR:Si vous constatez qu'il manque des particules de caoutchouc blanc sur le tableau, veuillez enfoncer lapartie N dans le tableau.
 IT:Se trovi che mancano le particelle di gomma bianca sulla tavola, premi la parte N sulla tavola.
 ES:Si descubre que faltan las partículas de goma blancas en el tablero, presione la parte N en el tablero.

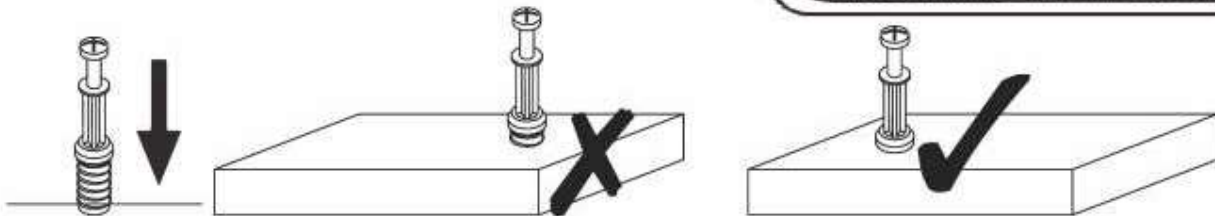

EN_QUICKFIT: Tighten quickfit until shoulder is flush with panel. Do not overtighten or undertighten.

FR_RACCORD RAPIDE: Faites serrer le raccord rapide jusqu'à ce que l'épaule soit parfaitement encastré dans le panneau. Il ne faut ni trop serrer ni insuffisamment serrer.

ES_QUICKFIT: Apriete quickfit hasta que el hombro se descargue con el panel. NO lo sobreapriete ni lo apriete poco.

DE_QUICKFIT: Ziehen Sie den Quickfit fest, bis die Schulter mit der Platte bündig ist. Bitte nicht zu fest oder zu schwach anziehen.

IT_MONTAGGIO RAPIDO: Stringere il montaggio rapido fino a quando la spalla è a filo con il pannello, non stringere troppo o troppo poco.

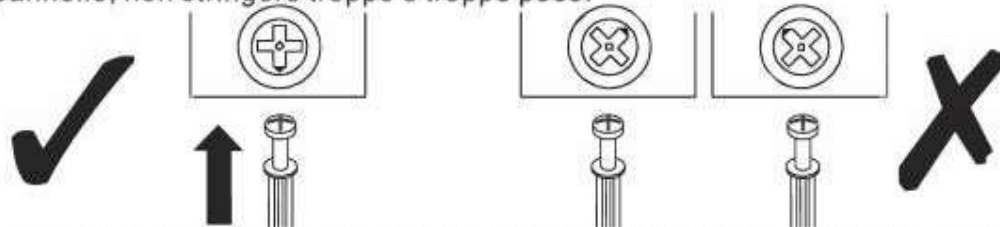

EN_CAM LOCK: When fitting cam lock, ensure starting position is correct before you insert connecting quickfit.

FR_SERRURE BATTEUSE: Avant d'insérer la serrure batteuse, veillez à la bonne orientation avant d'insérer le raccord rapide.

ES_CIERRE DE LA CÁMARA: Cuando instale el cierre de la cámara, asegúrese de que la posición de inicio es correcta antes de que inserte el quickfit conector.

DE_CAM-LOCK: Achten Sie bei der Montage des Cam-Locks auf die richtige Ausgangsposition, bevor Sie den Quickfit einsetzen.

IT_BLOCCAGGIO A CAMMA: Quando si monta il bloccaggio a camma, assicurarsi che la posizione iniziale sia corretta prima di inserire il montaggio rapido di collegamento.

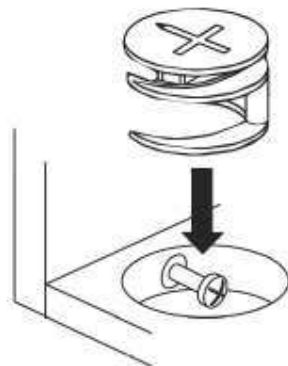

EN_Quickfit head should be in the centre of the cam lock when the two panels are joined.

Cam lock should be inserted before quickfit.

FR_Lorsque les deux panneaux sont assemblés, la tête du raccord rapide doit reposer au centre de la serrure batteuse.

Il faut insérer la serrure batteuse avant le raccord rapide.

ES_El cabezal del quickfit debe estar en el centro del cierre de la cámara cuando se unan los dos paneles.

Se debe insertar el cierre de la cámara antes que el quickfit.

DE_Der Quickfit-Kopf sollte sich in der Mitte des Cam-Locks befinden, wenn die beiden Platten zusammengefügt sind.

Der Cam-Lock sollte vor dem Quickfit eingesetzt werden.

IT_La testa del montaggio rapido deve trovarsi al centro del bloccaggio a camma quando i due pannelli sono uniti.

Il Bloccaggio a Camma deve essere inserito prima del montaggio rapido.

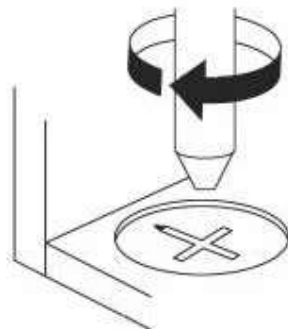

EN_Turn cam lock clockwise to tighten.

FR_Faites tourner la serrure batteuse dans le sens des aiguilles d'une montre pour la resserrer.

ES_Gire el cierre de la cámara en sentido horario para apretarlo.

DE_Drehen Sie den Cam-Lock im Uhrzeigersinn, um ihn festzuziehen.

IT_Ruotare il bloccaggio a camma in senso orario per stringere.

EN_NOTE: Pull inner and outer drawer runners apart before fixing them to panels.

FR_REMARQUE: Avant de fixer les glissières de tiroir aux panneaux, tirez vers l'extérieur et poussez vers l'intérieur de chacun des tiroirs.

ES_NOTA: retire los rieles interiores y exteriores antes de fijarlos a los paneles.

PT_NOTA: Separar as corrediças das gavetas interiores e exteriores antes de fixar para os painéis.

DE_HINWEIS: Ziehen Sie die inneren und äußeren Schubladenführung auseinander, bevor Sie sie an den Platten befestigen.

IT_NOTA: Separare le guide interne ed esterne del cassetto prima di fissarle ai pannelli.



EN_Slide drawer runners apart until the drawer lock can be seen, as shown.

FR_Les glissières de tiroir doivent être ouvertes jusqu'à ce que la serrure du tiroir soit visible, comme indiqué.

ES_Deslice a un lado los rieles del cajón hasta que se pueda ver el cierre del armario, tal y como se muestra.

PT_Deslizam-se as gavetas até se poder ver o fecho da gaveta, como se mostra.

DE_Schieben Sie die Schubladenführungen auseinander, bis das Schubladenschloss sichtbar ist, gemäß der Abbildung.

IT_Far scorrere le guide del cassetto fino a quando non sia visibile il blocco di scorrimento, come mostrato.

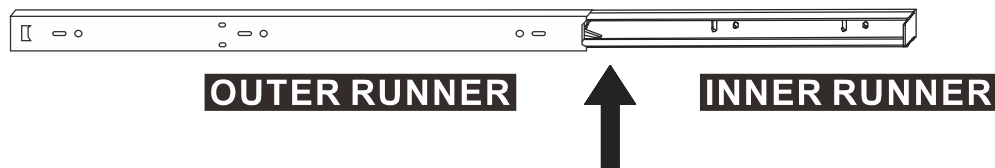

EN_Press and hold the drawer runner lock and then continue to slide drawer runners apart, as shown.

FR_En appuyant et en maintenant le verrouillage des glissières de tiroir, vous pouvez continuer à les écarter l'une de l'autre, comme indiqué.

ES_Mantenga presionado el cierre del riel del cajón y después continúe deslizando a un lado los rieles de los cajones, tal y como se muestra.

PT_Manter pressionado o fecho de gaveta e depois continuar a deslizar as corrediças da gaveta, como mostrado.

DE_Drücken und halten Sie die Verriegelung der Schubladenführung und schieben Sie die Schubladenführungen wie abgebildet weiter auseinander.

IT_Tenere premuto il blocco di scorrimento e quindi continuare a far scorrere la guida, come mostrato.

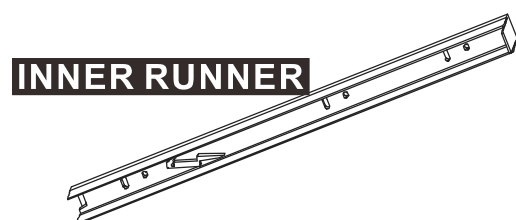
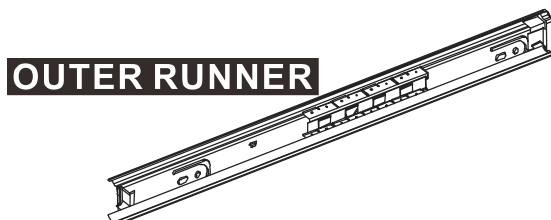
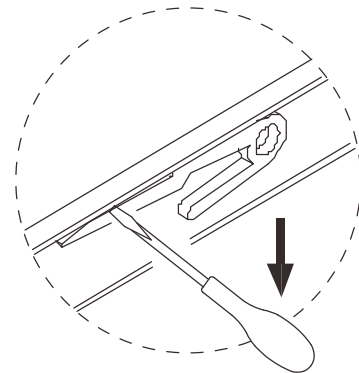

EN_Your inner and outer drawer runners are ready to be fixed to panels.

FR_Il est possible, à présent, de fixer les glissières intérieures et extérieures de vos tiroirs sur des panneaux.





ES_Los rieles interiores y exteriores del cajón están listos para fijarse a los paneles.

PT_As corrediças das gavetas interiores e exteriores estão prontas para serem fixadas nos painéis.

DE_Ihre inneren und äußeren Schubladenführungen sind bereit, an den Platten befestigt zu werden.

IT_Le guide interne ed esterne sono pronte per essere fissate ai pannelli.

01

Ax8 	Bx12 	Dx2 	Fx4 
φ8*40			φ3.5*14

UK: Rotate the rebound clockwise to retract inward,

and counterclockwise rotate the rebound to bounce outward

DE: Drehen Sie die Zugstufe im Uhrzeigersinn, um sie nach innen einzufahren,

und drehen Sie die Zugstufe gegen den Uhrzeigersinn, um nach außen zu springen

FR: Tournez le rebond dans le sens inverse des aiguilles d' une montre pour le rétracter vers l' intérieur,

et tournez le rebond dans le sens inverse des aiguilles d' une montre pour rebondir vers l' extérieur

IT : Ruotare il rimbalzo in senso orario per ritrarlo verso l'interno e in senso antiorario



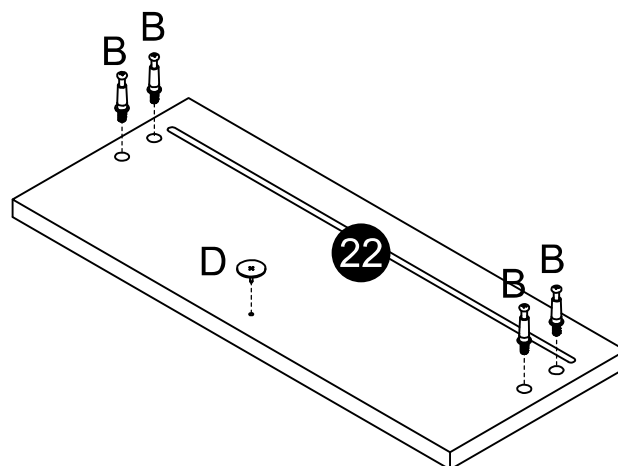
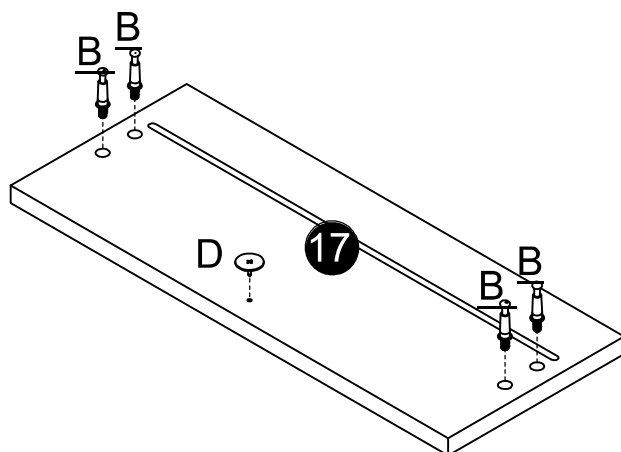
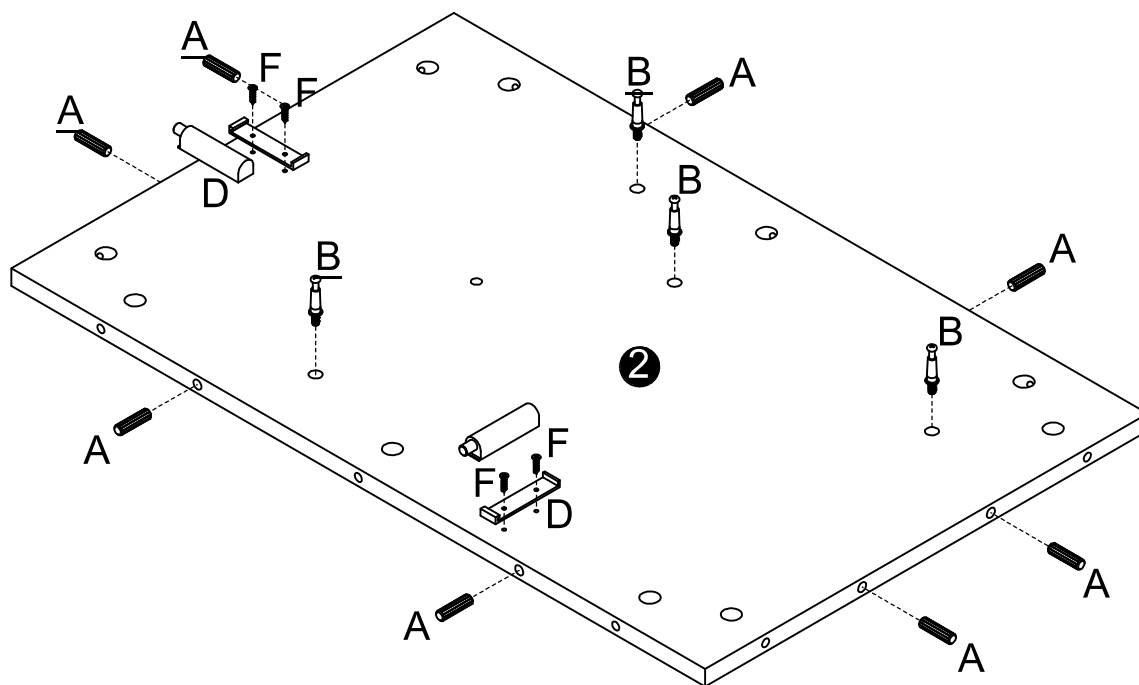
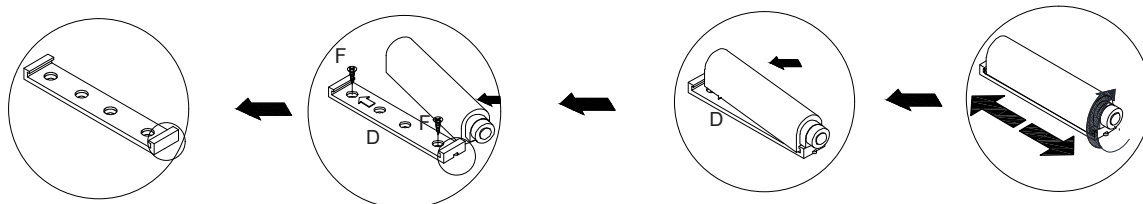

ruotare il rimbalzo per rimbalzare verso l'esterno

ES : Gire el rebote en el sentido de las agujas del reloj para retraerse hacia adentro y gire

el rebote en sentido contrario a las agujas del reloj para rebotar hacia afuera



02

Ax9 	Bx8 	Fx4 	Gx1  CL	Gx1  CR
φ8*40		φ3.5*14		

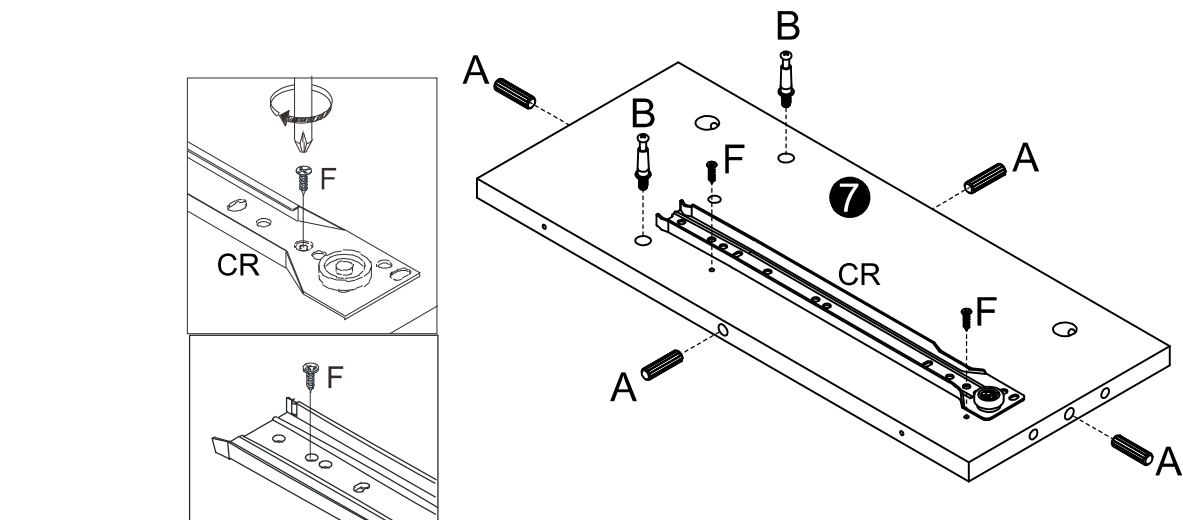
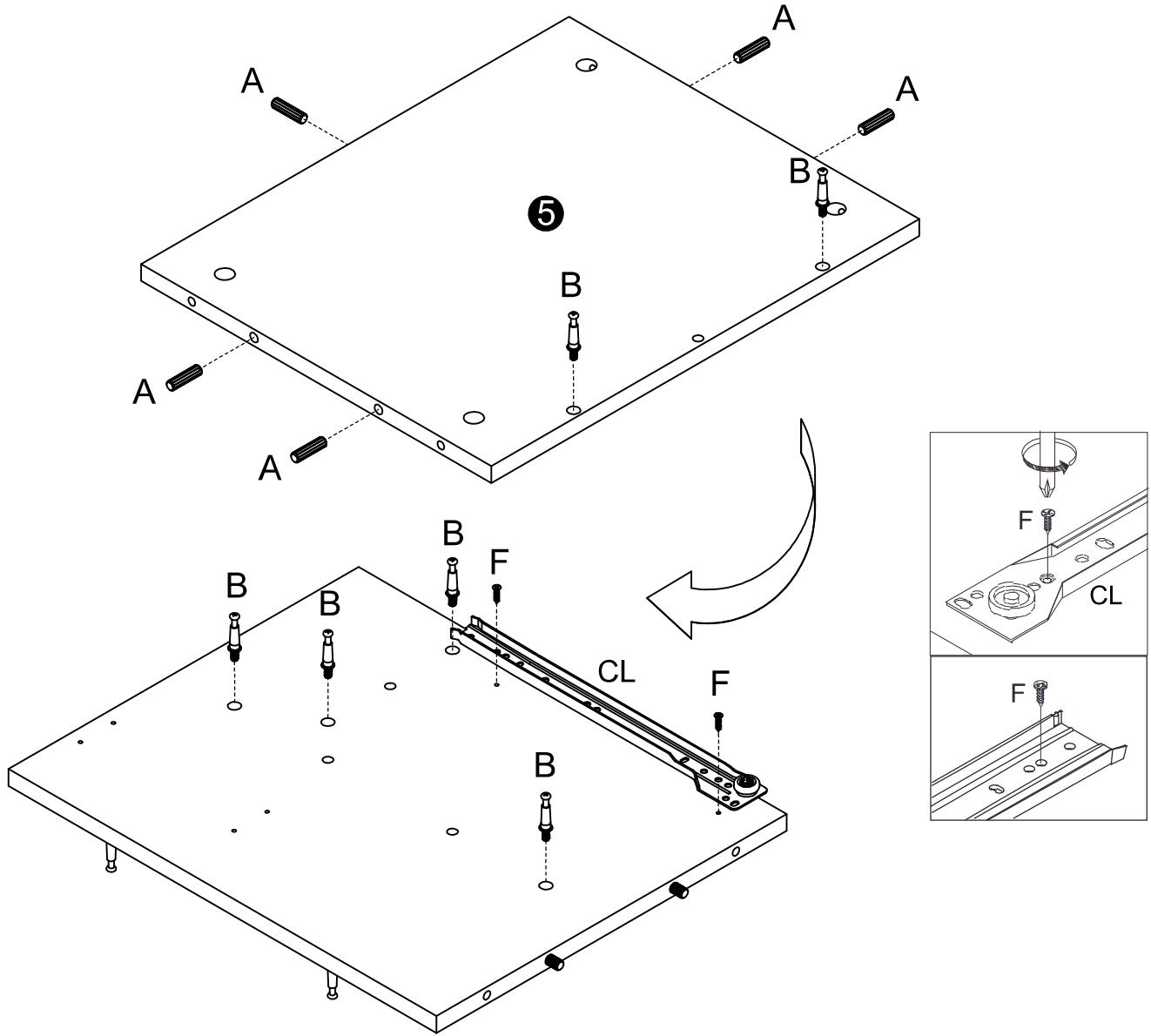

03

Ax5



Bx10



$\phi 8 \times 40$

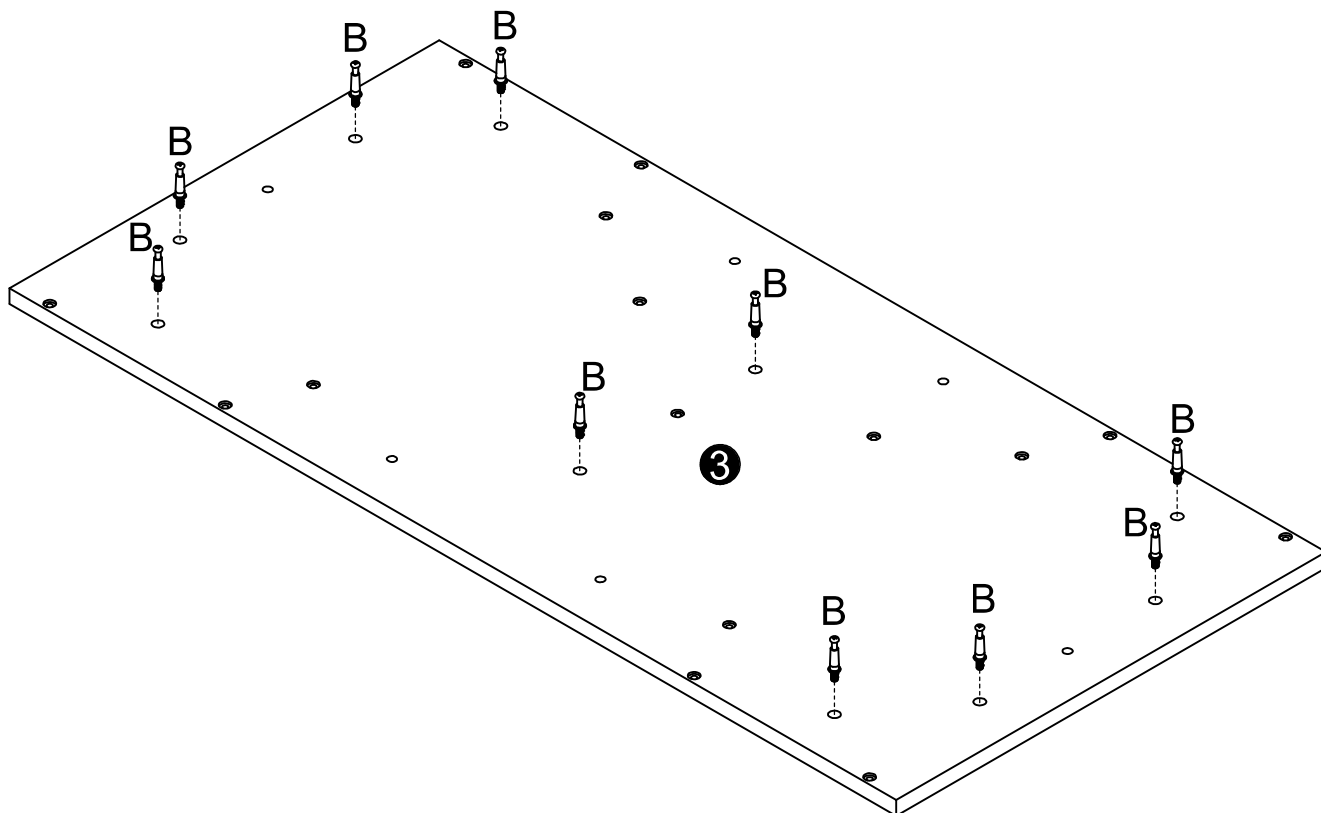
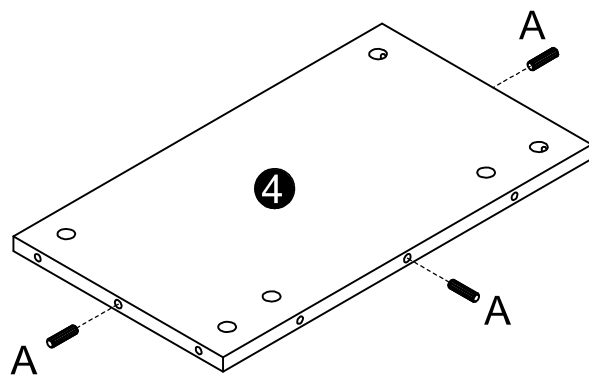
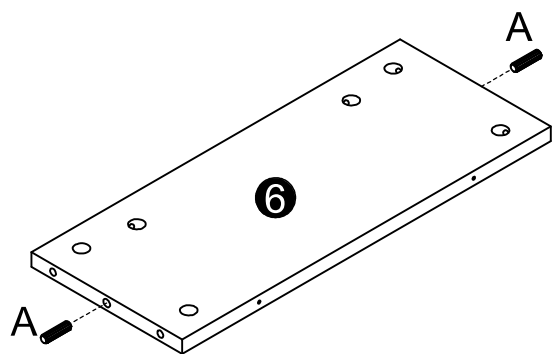

04

Ax2





Bx12

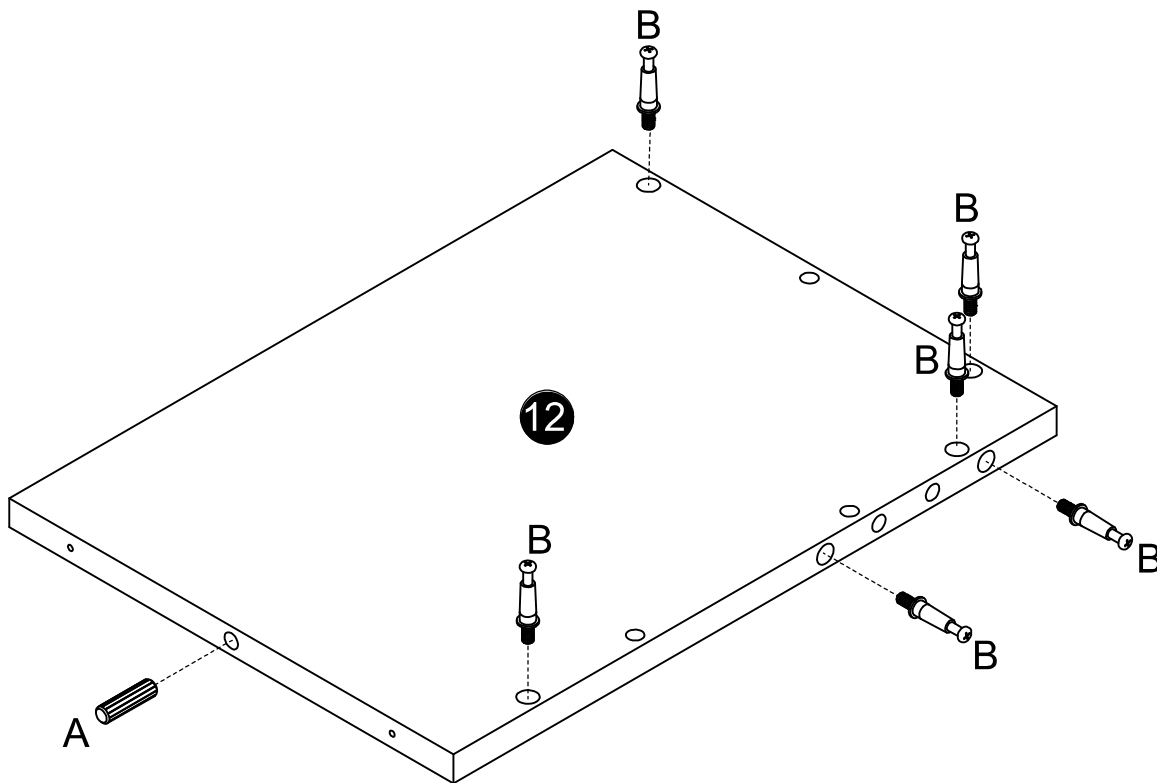
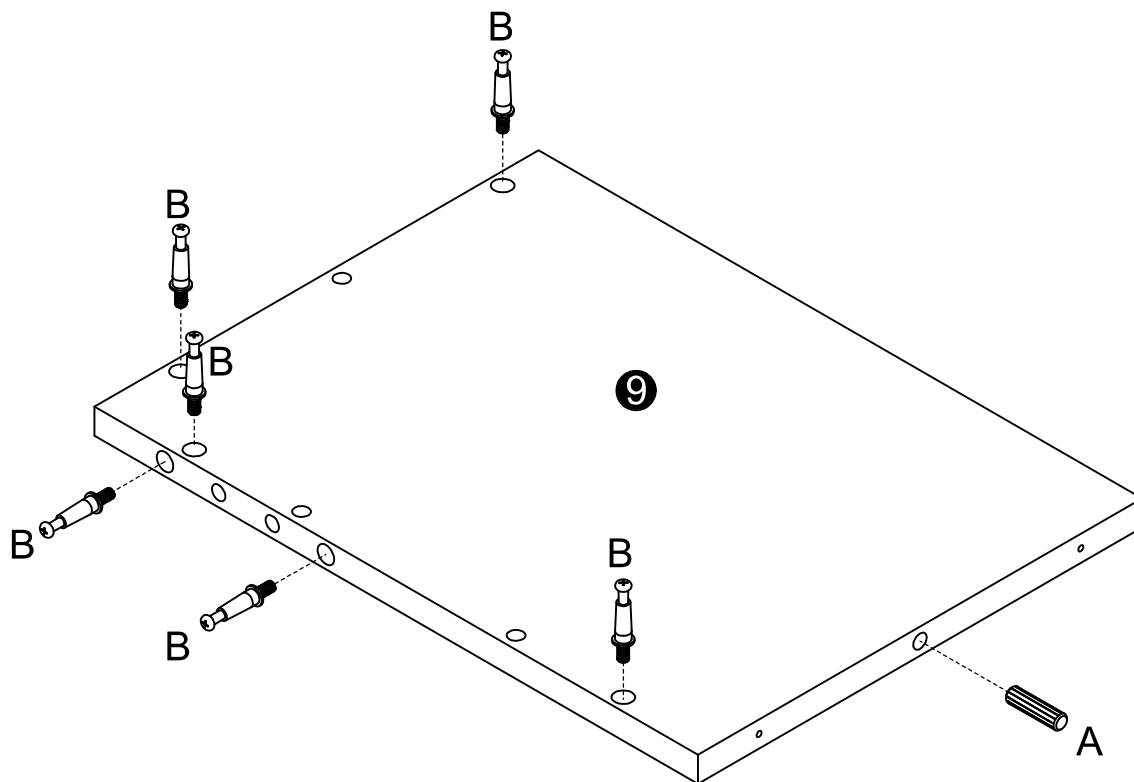

φ8*40

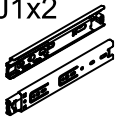

05

Ax8 	Bx4 	Fx4 	J1x2 
$\phi 8 \times 40$		$\phi 3.5 \times 14$	

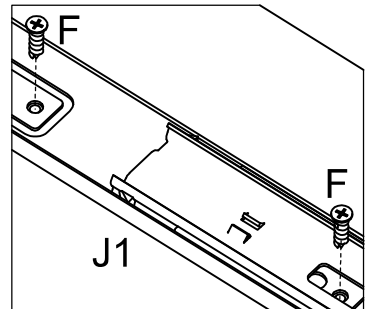
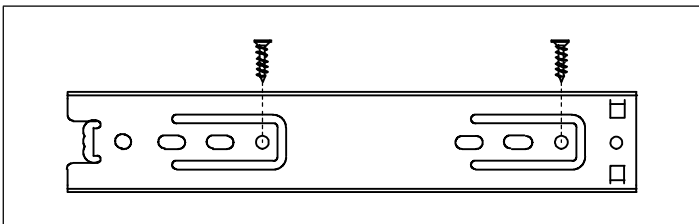
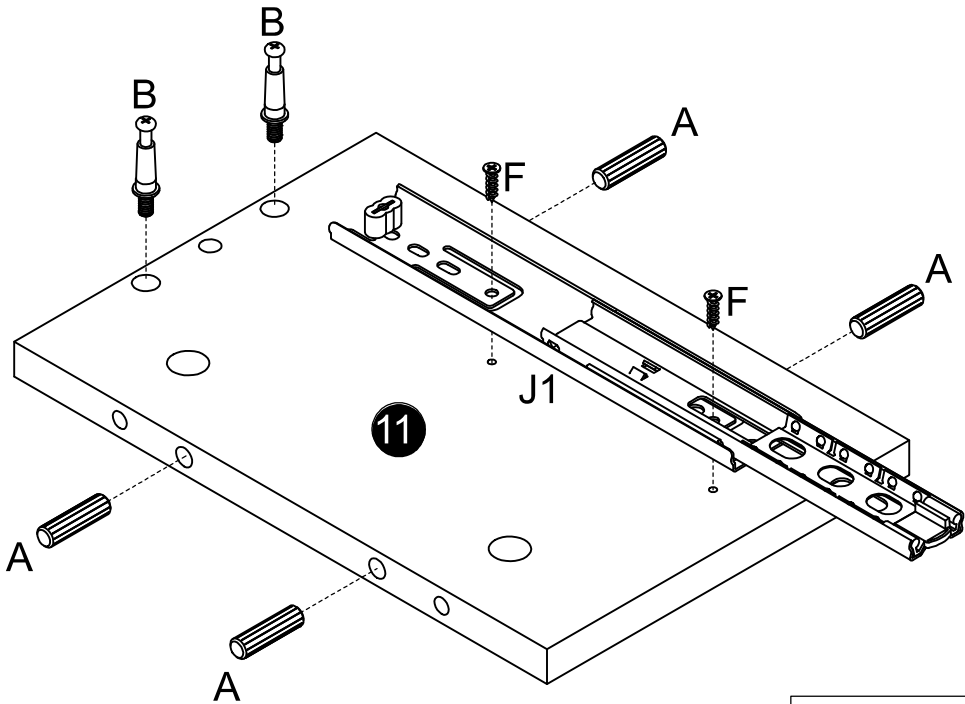
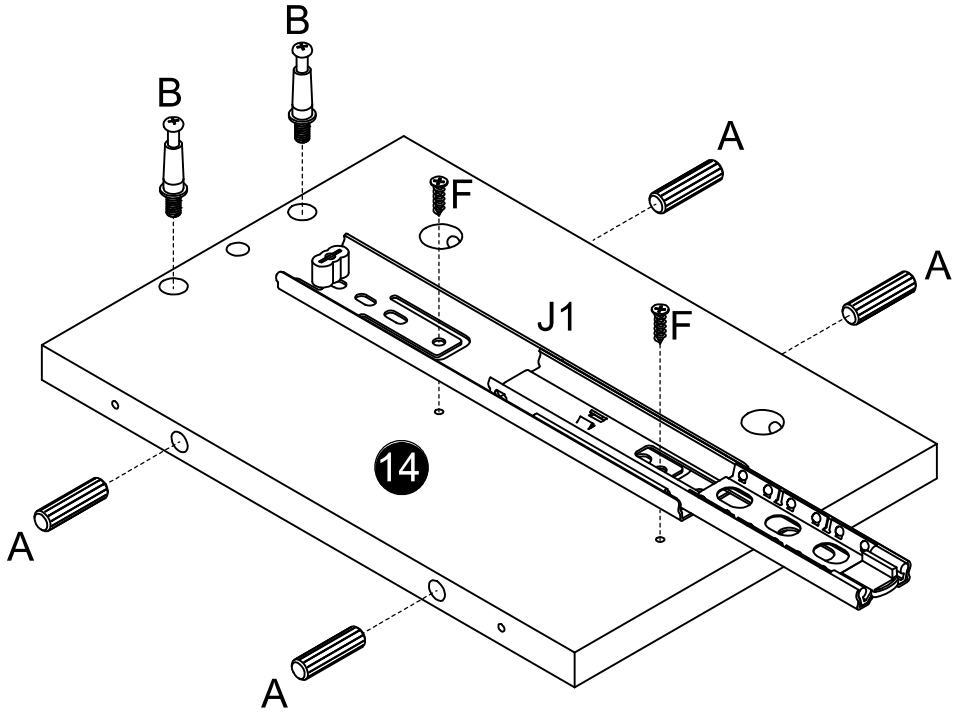

06

Ax17



Bx8



φ8*40

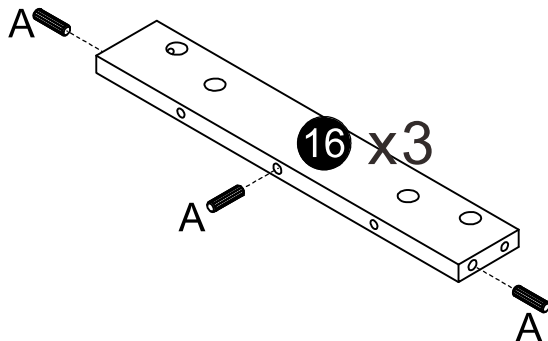
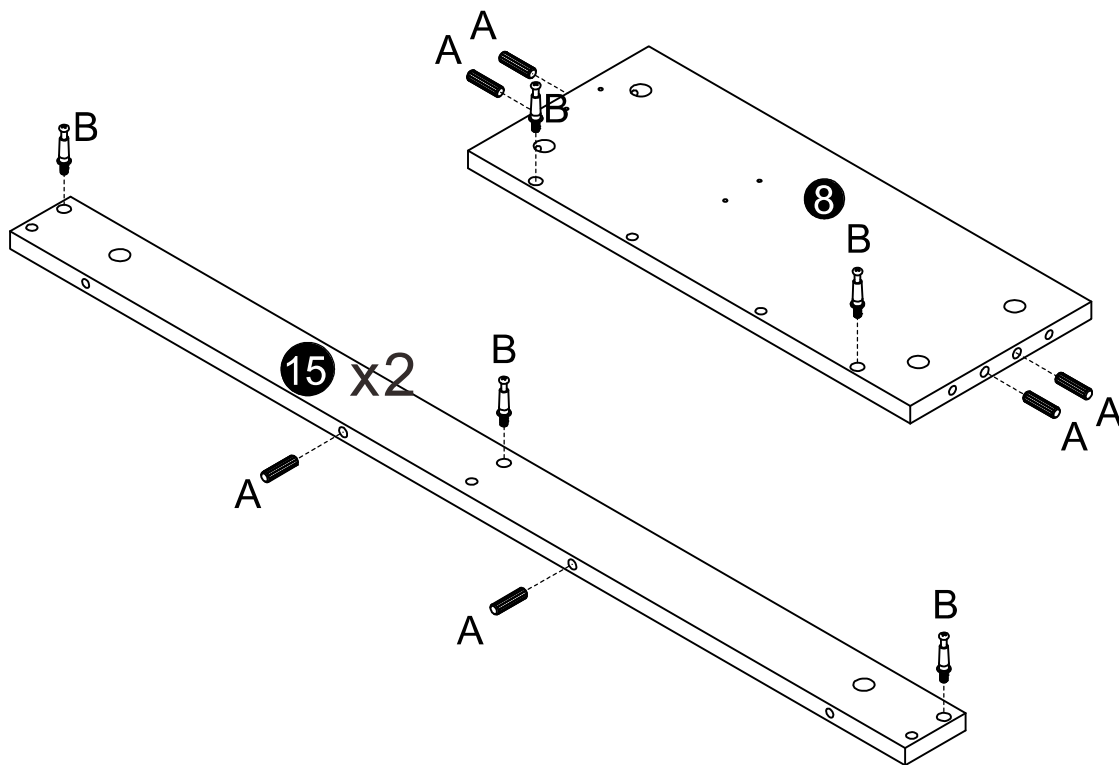

07

Ax4



Bx14



$\phi 8 \times 40$

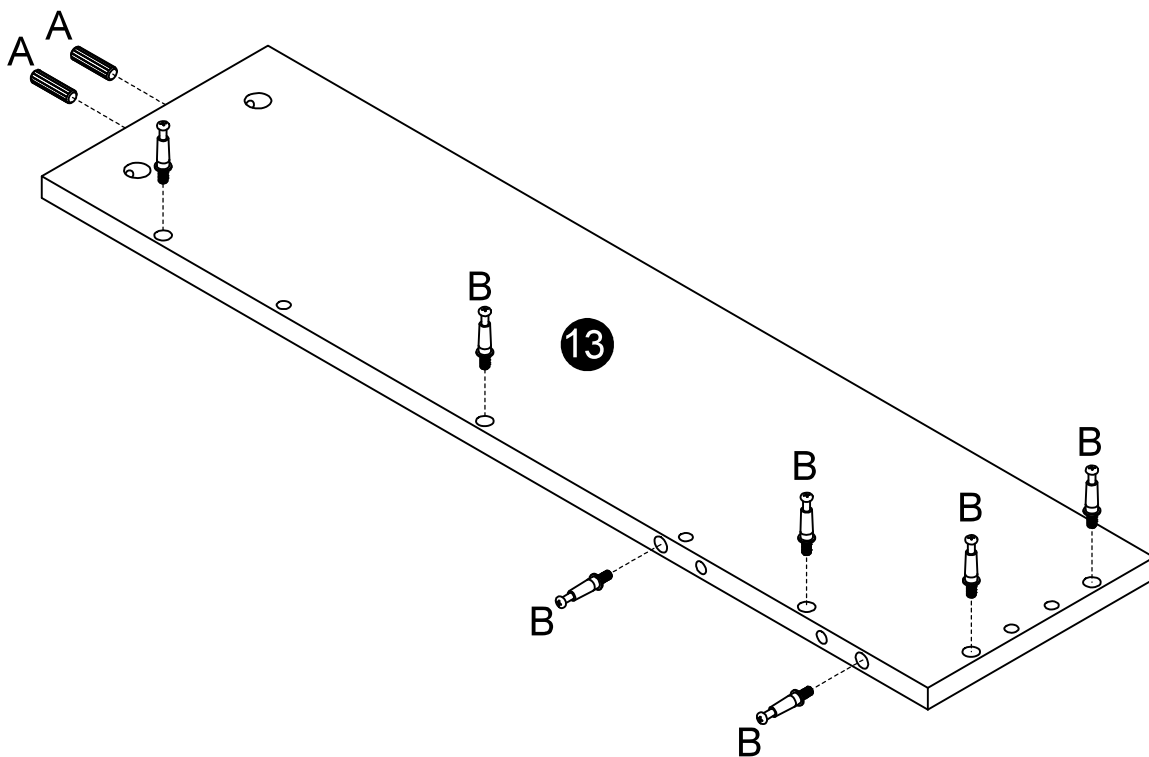
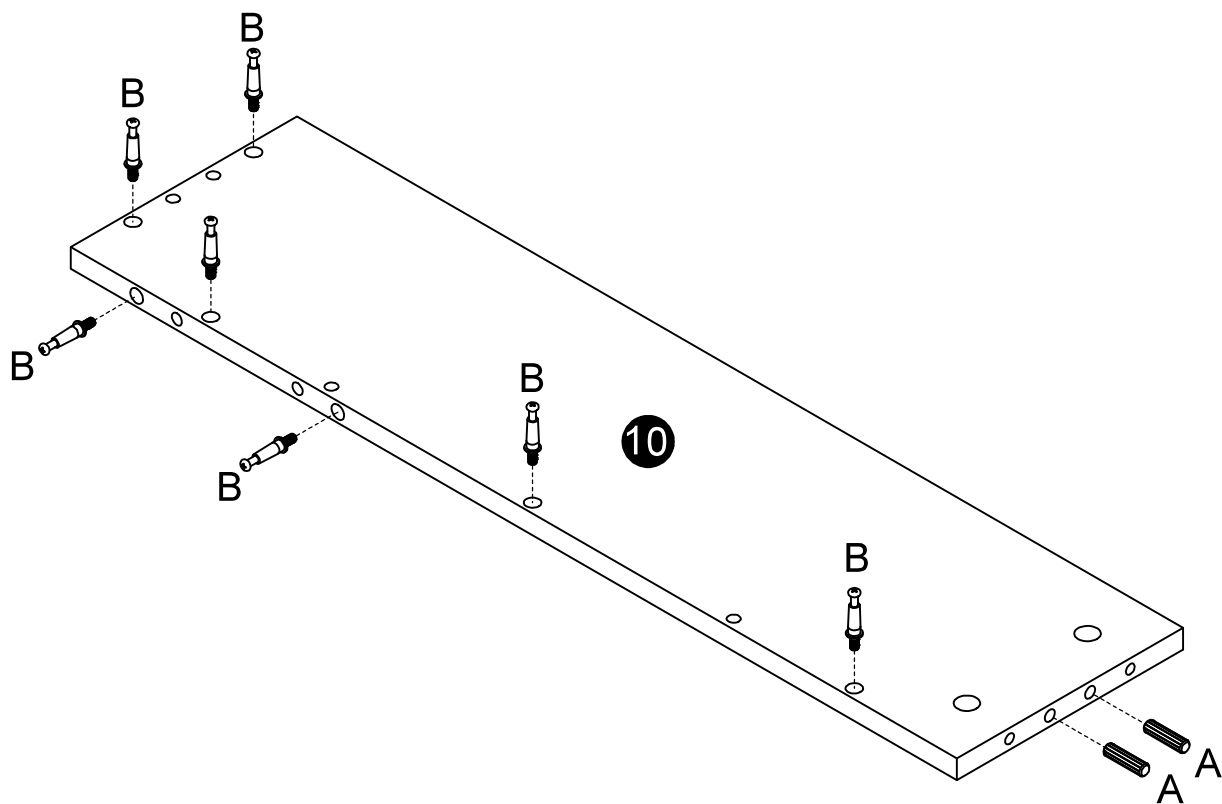

08

Cx4

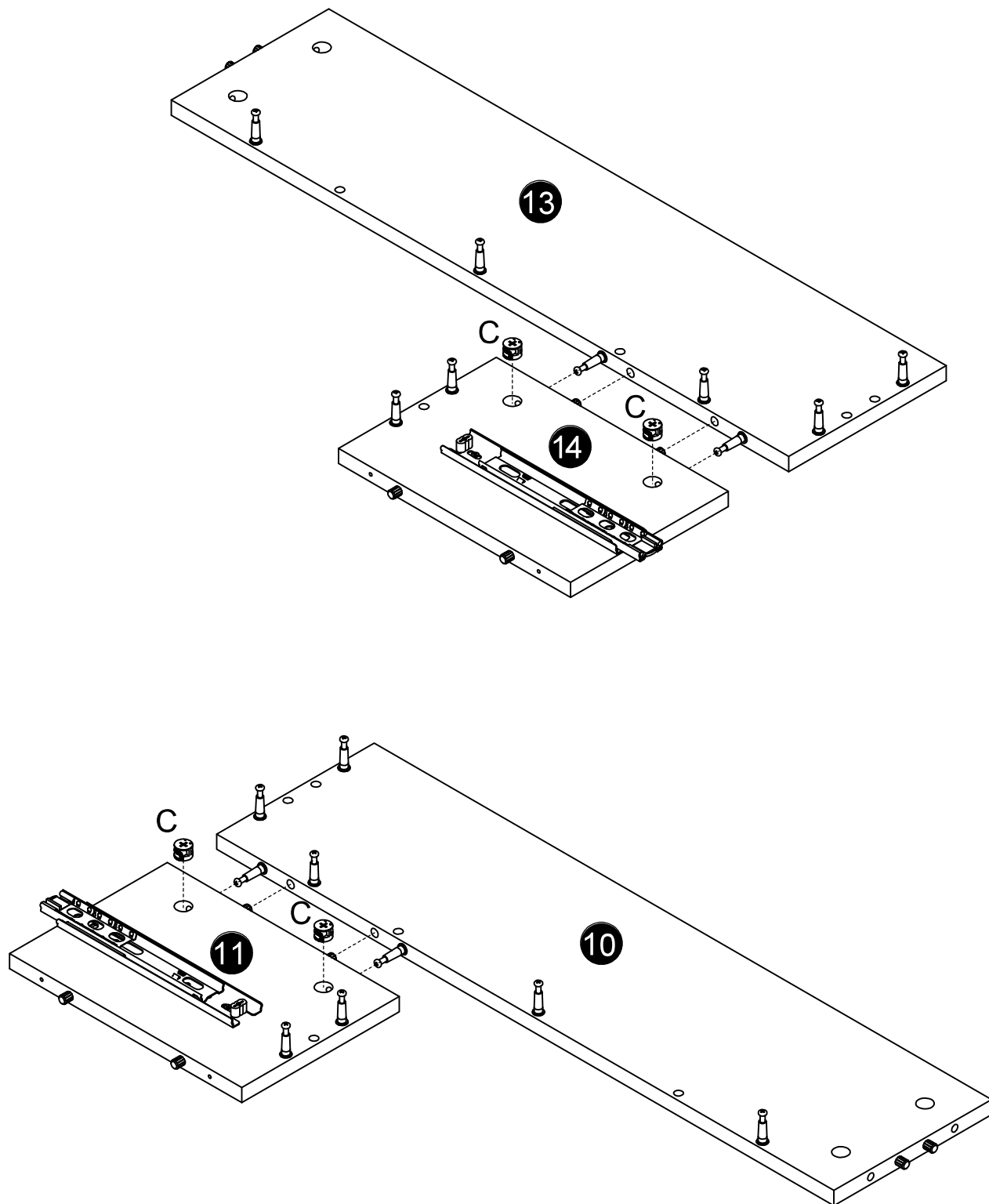

09

Cx4

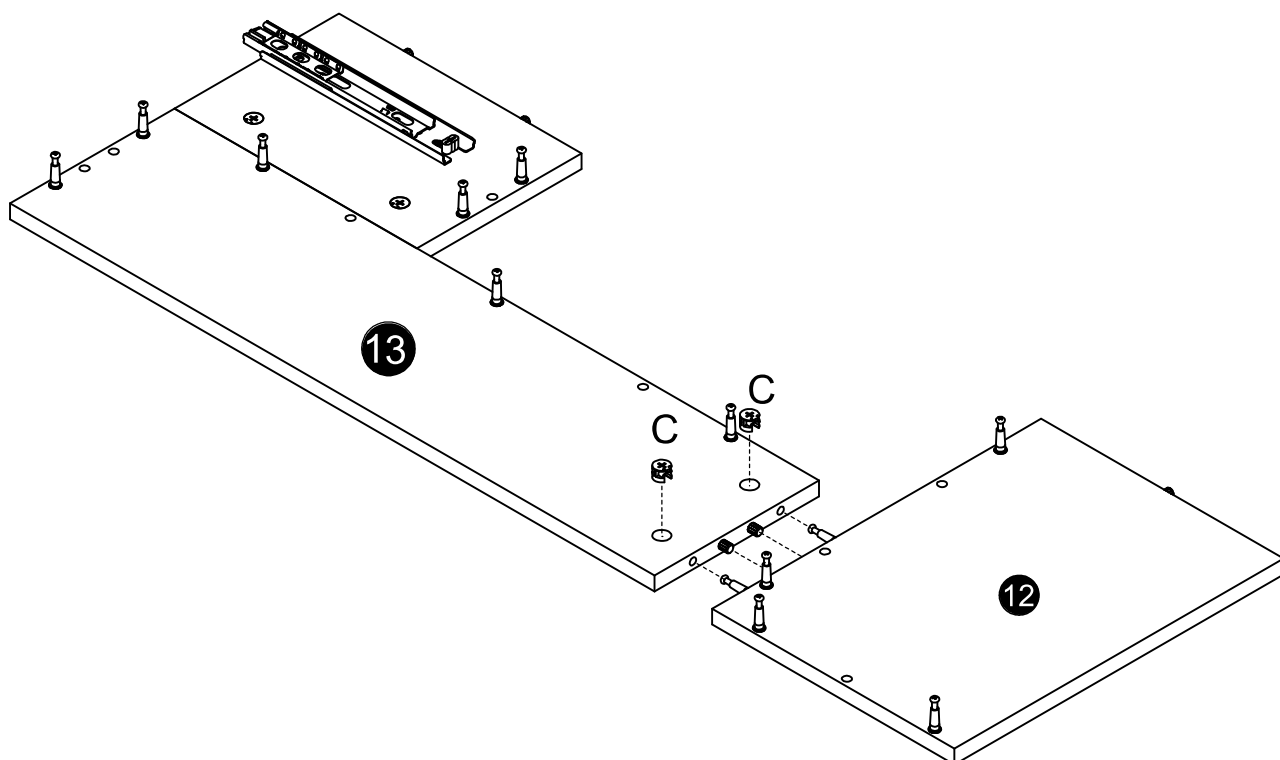
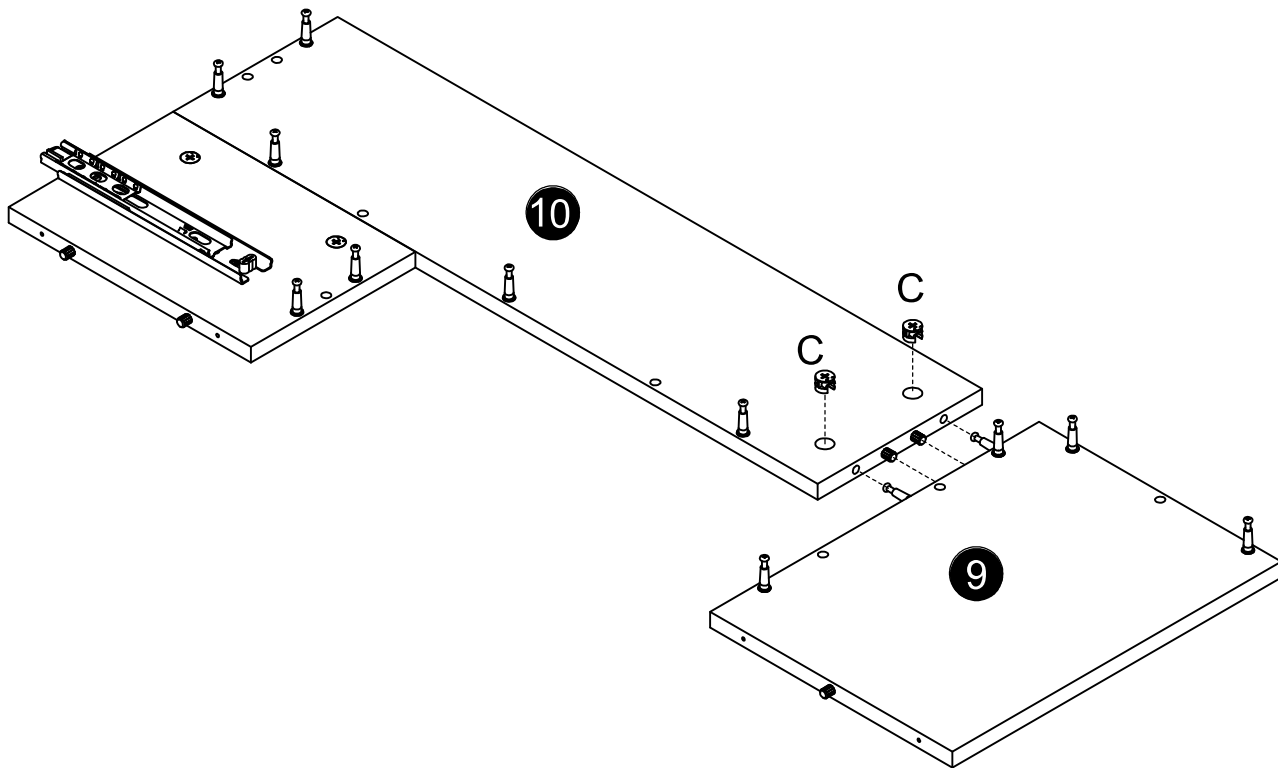

10

Cx2

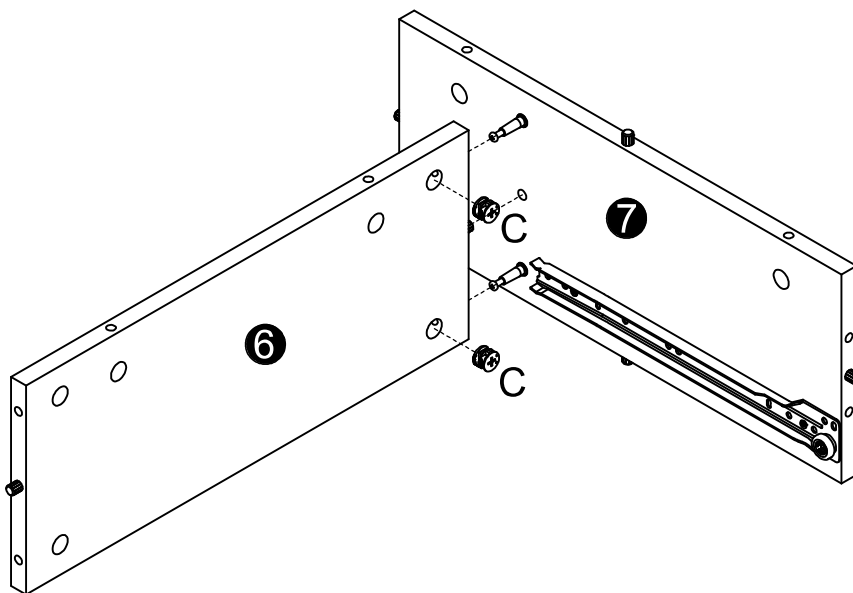
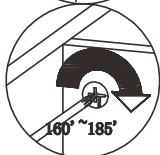
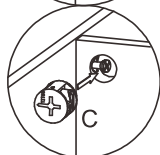
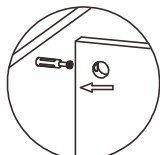

11

Cx2

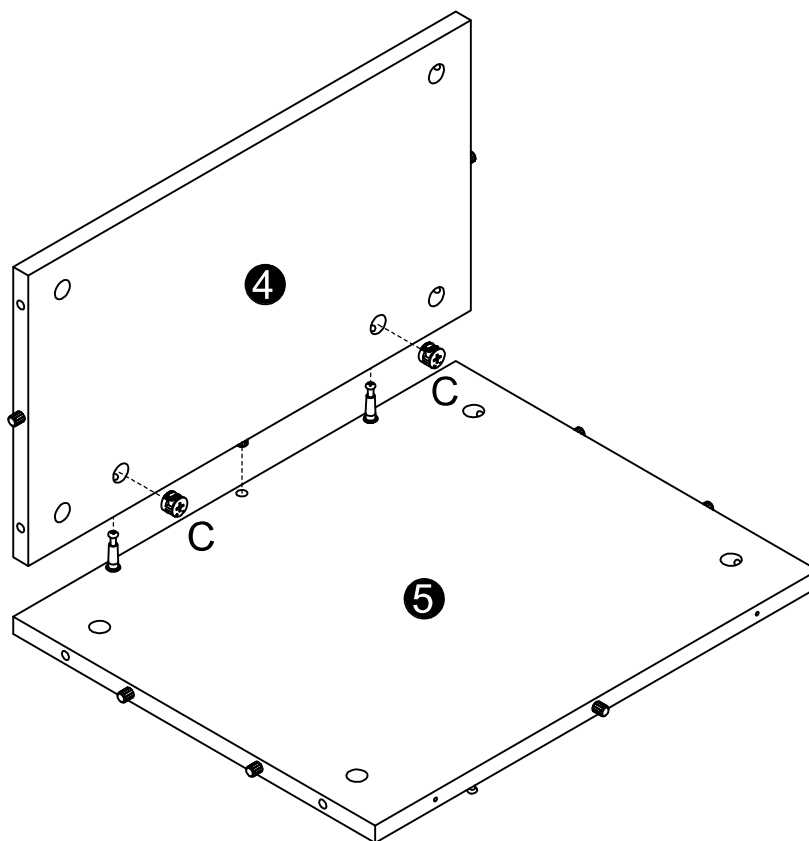
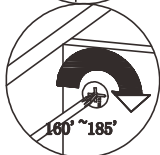
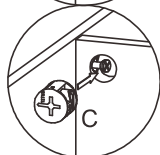

12

Cx4

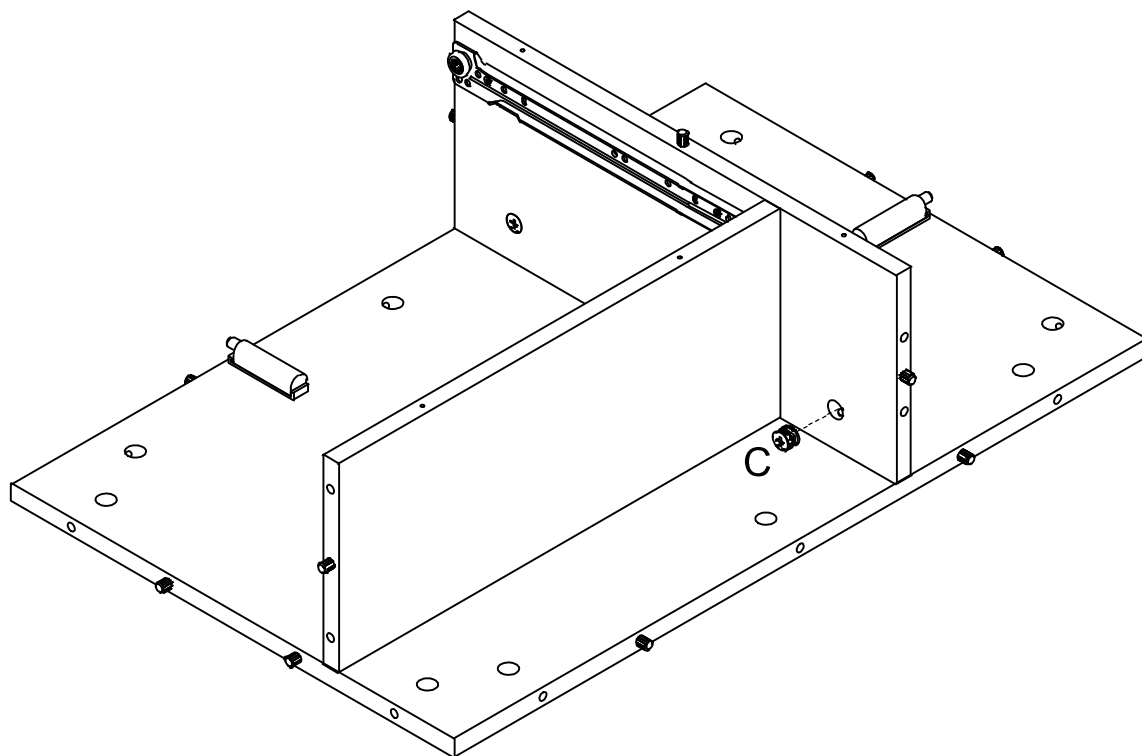
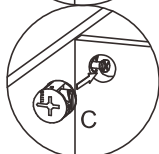
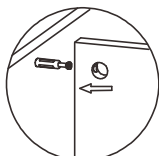
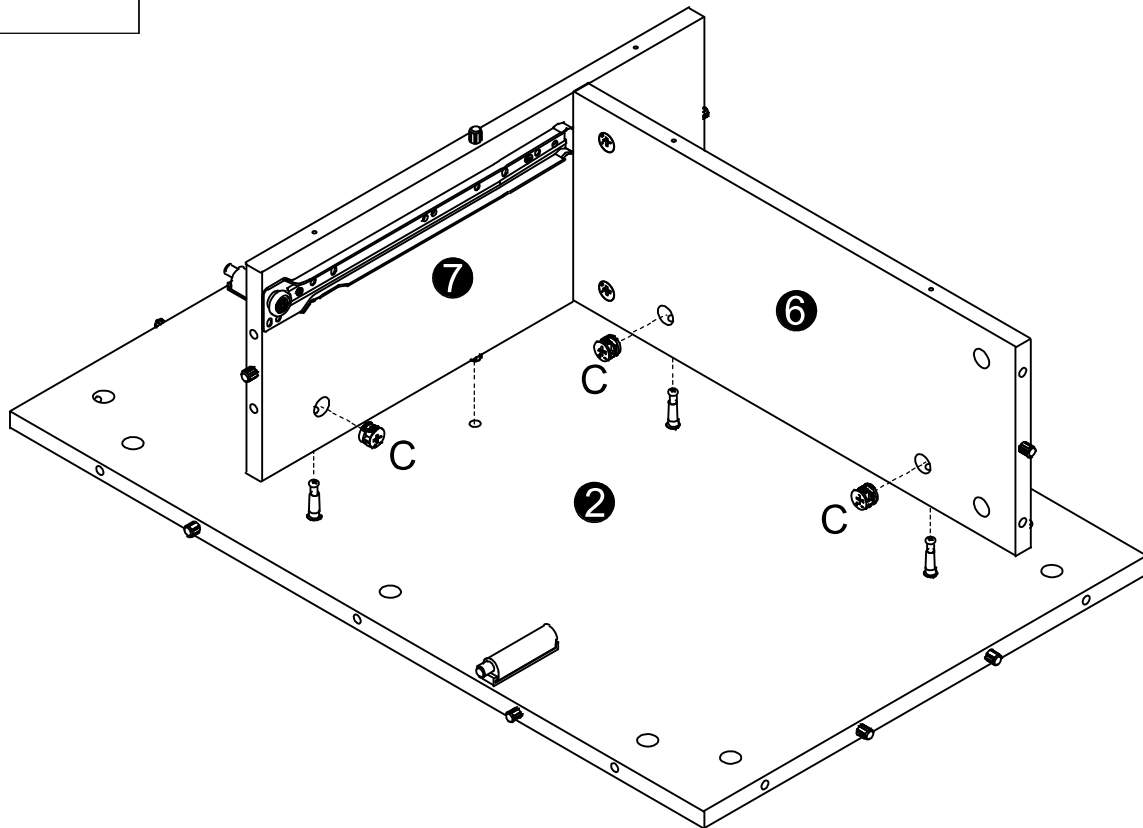

13

Cx6

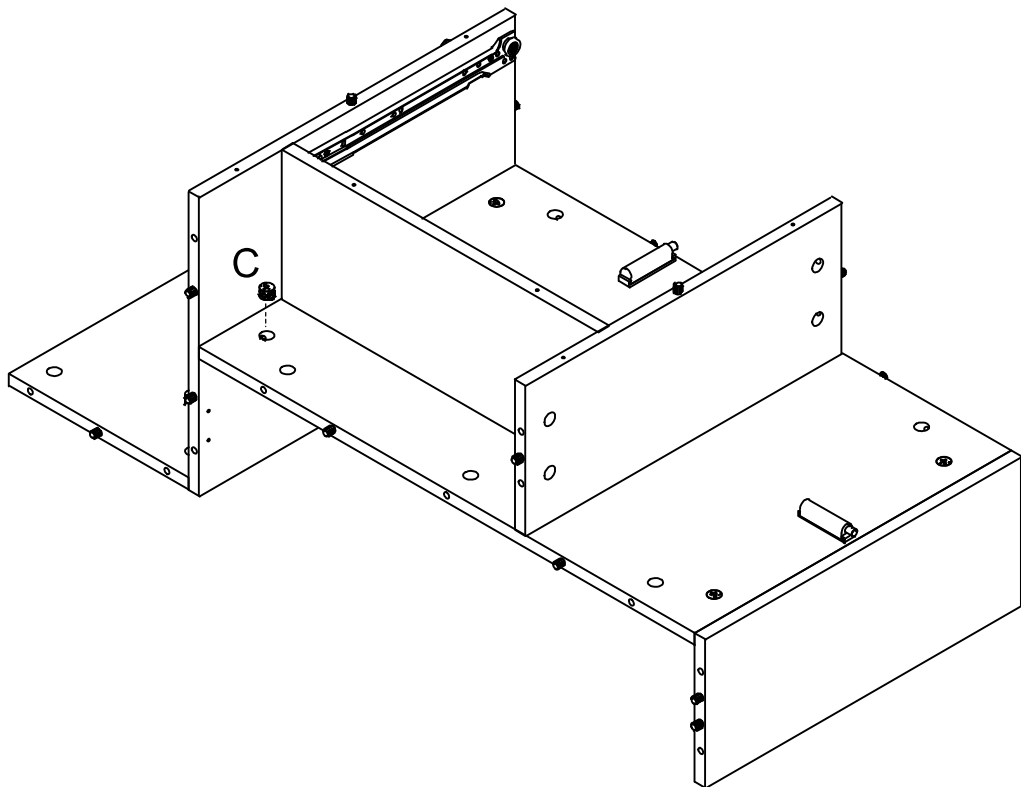
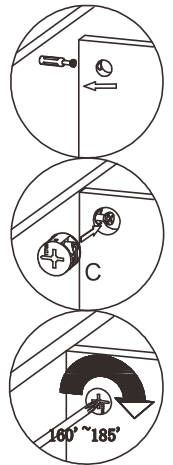
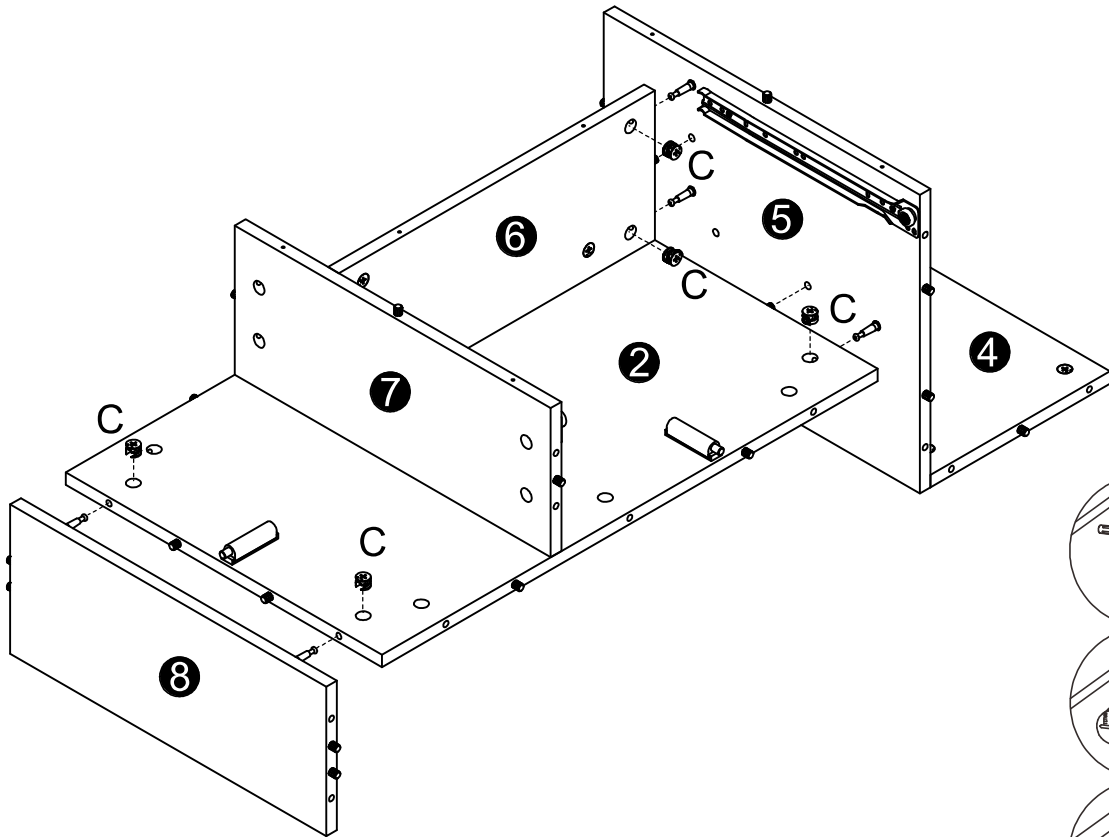

14

Cx22

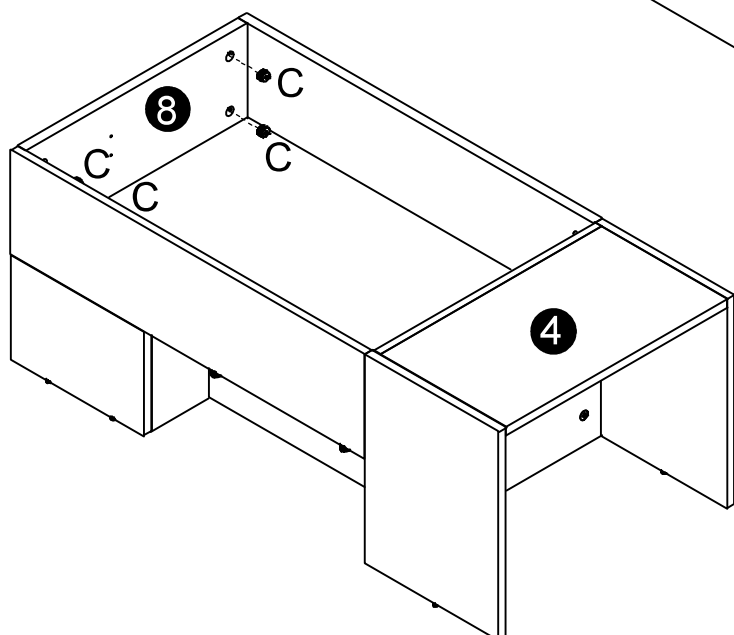
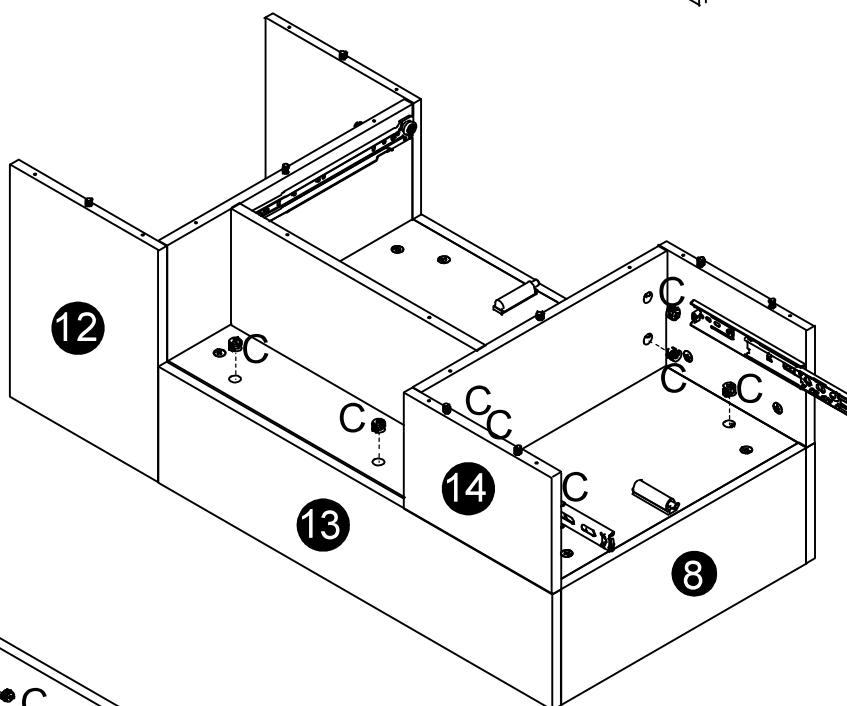
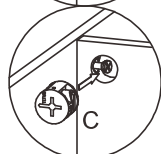
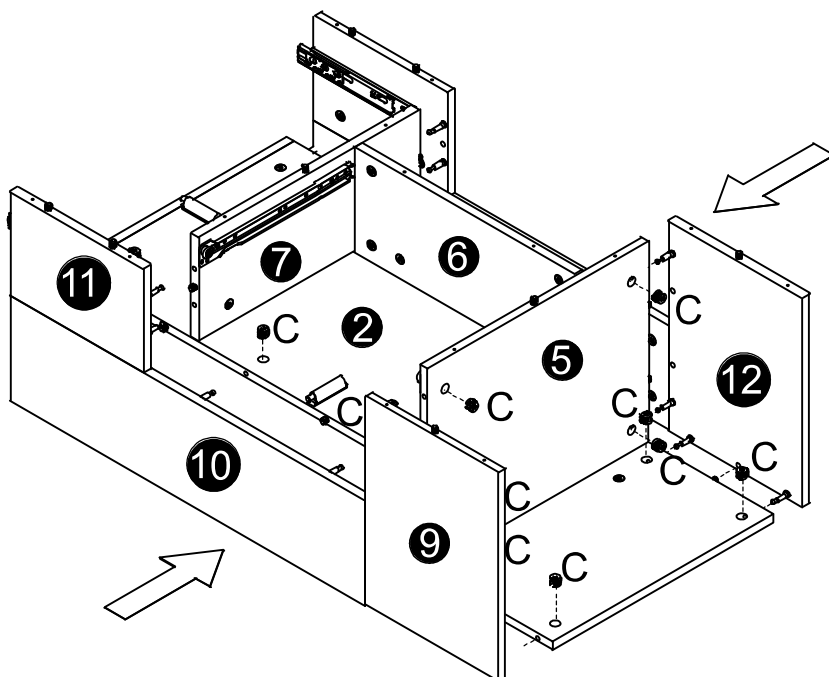

15

Ex14



φ3.5*35

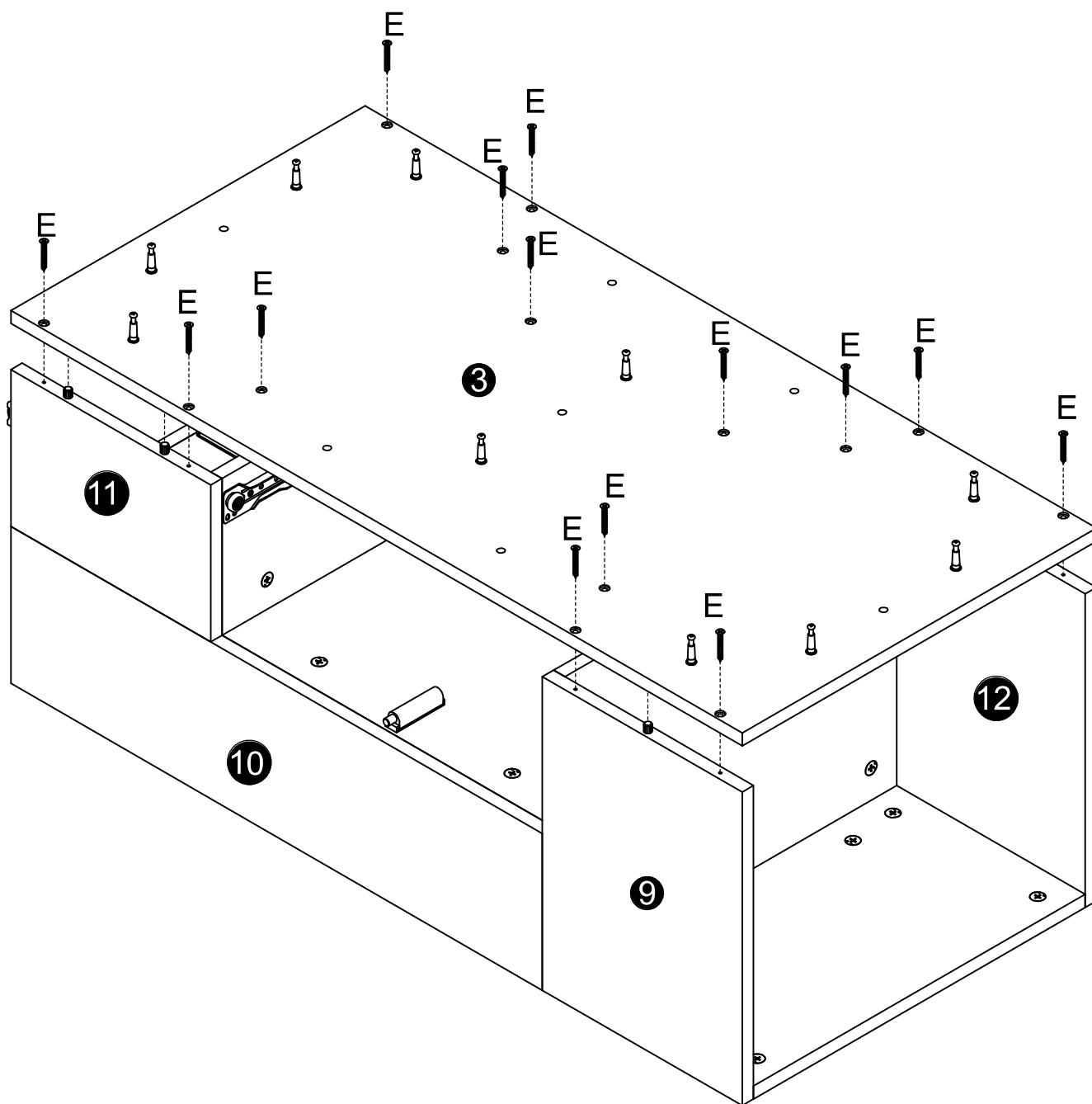

16

Cx6

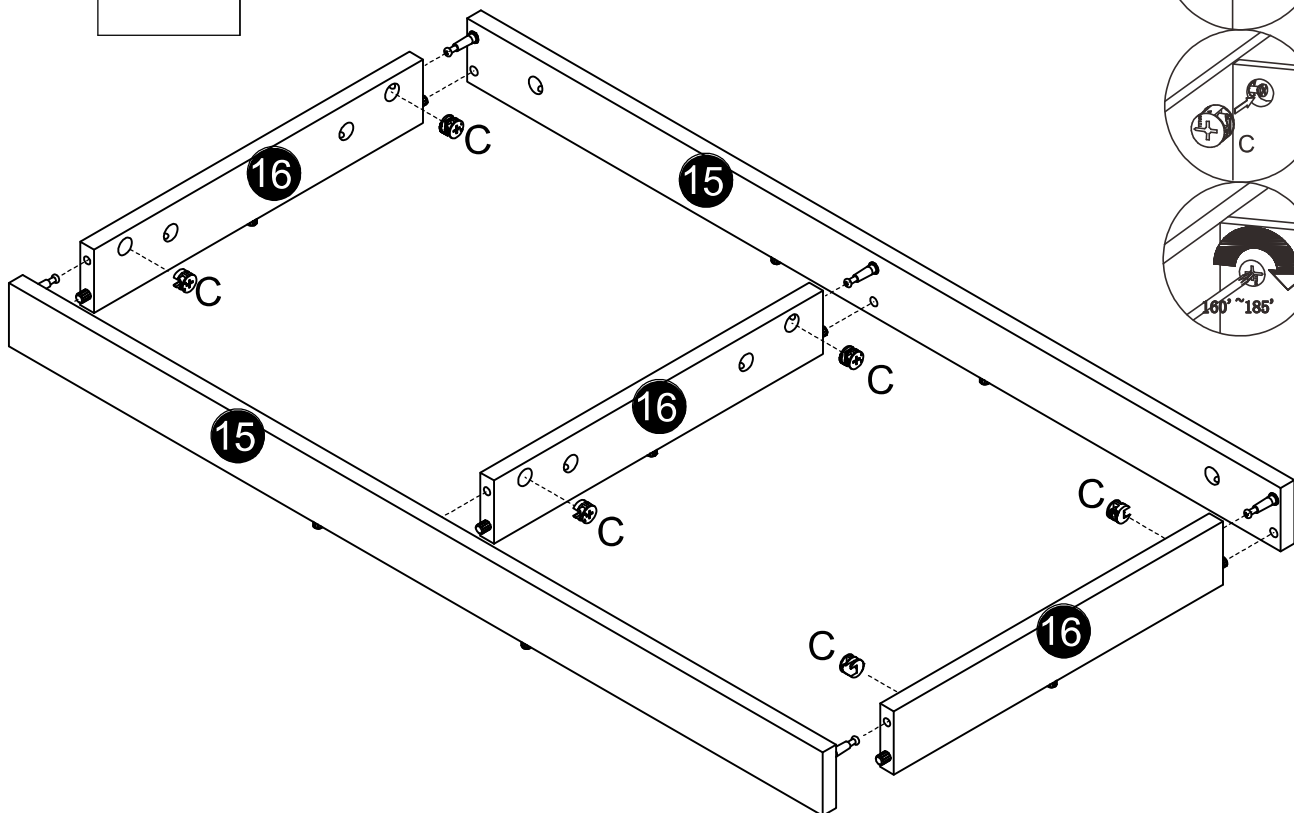

17

Fx8



φ3.5*14

x1

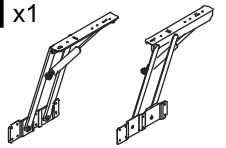

Left Side
Linke Seite
Côté Gauche
Lado Izquierdo
Lato Sinistro

Right Side
Rechte Seite
Côté Droit
Lado Derecho
Lato Destro

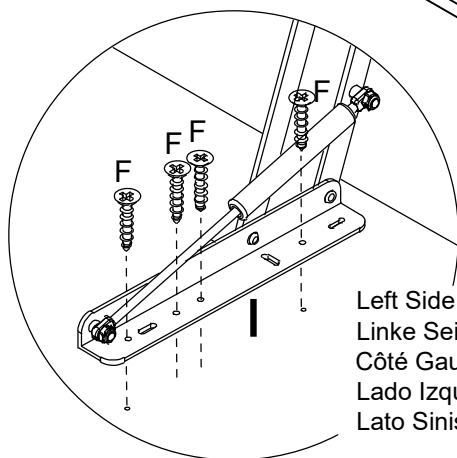
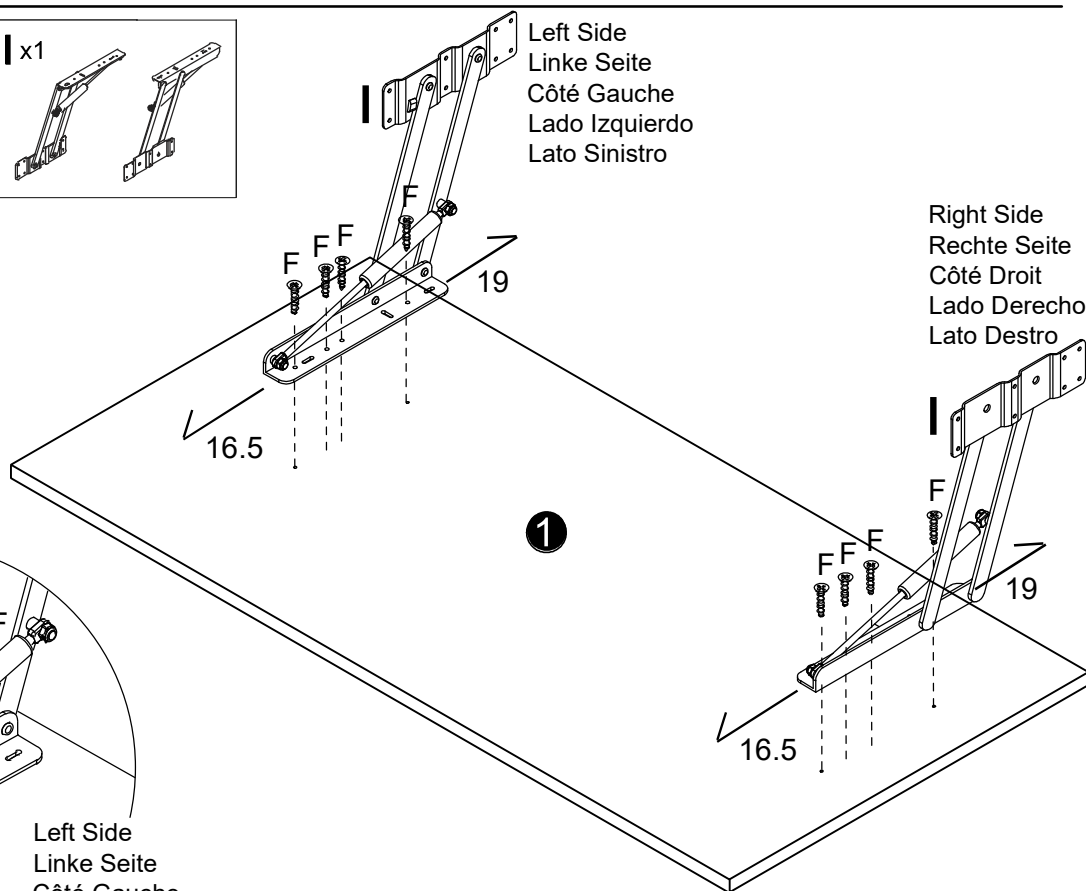

Left Side
Linke Seite
Côté Gauche
Lado Izquierdo
Lato Sinistro

18

Cx10

Hx10

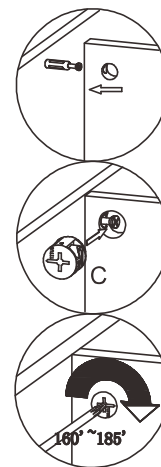
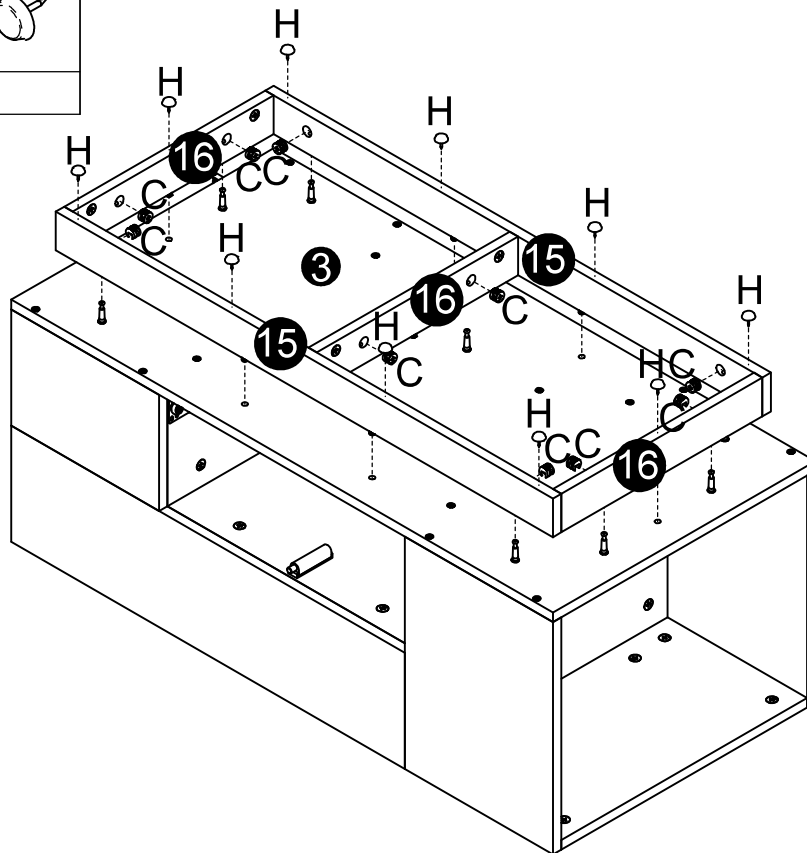
**19**

Lx1



2800mm

EN: Tear off the back tape
 FR: Déchirer le ruban adhésif
 arrière
 DE: Reiß das hintere Band ab
 IT: Rimuovere il nastro
 posteriore
 ES: Arrancar la cinta trasera

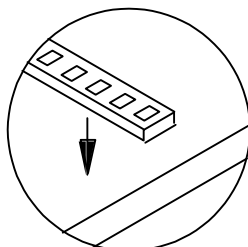
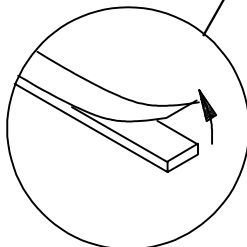
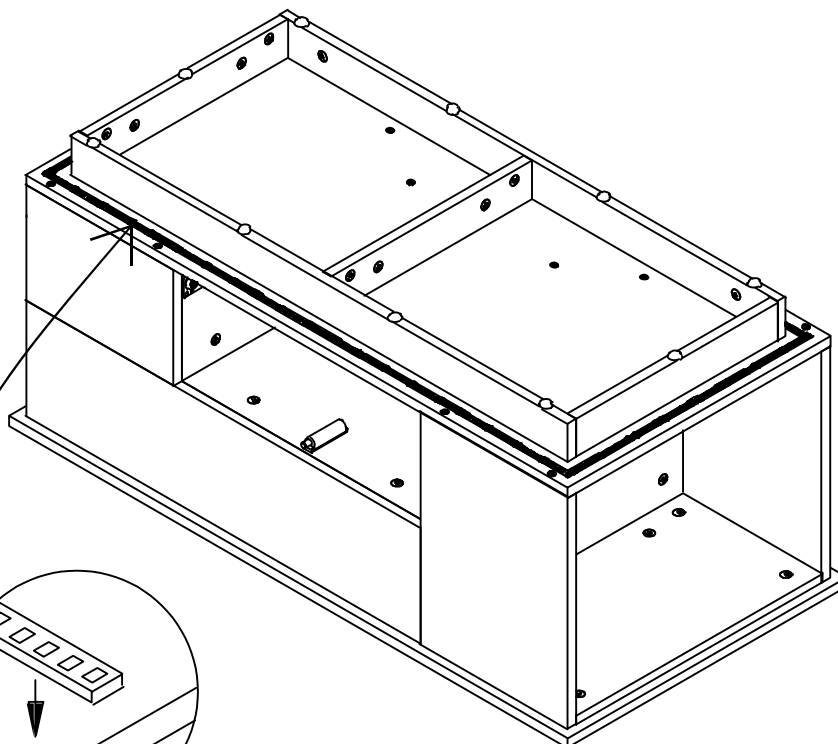

20

Fx16



φ3.5*14

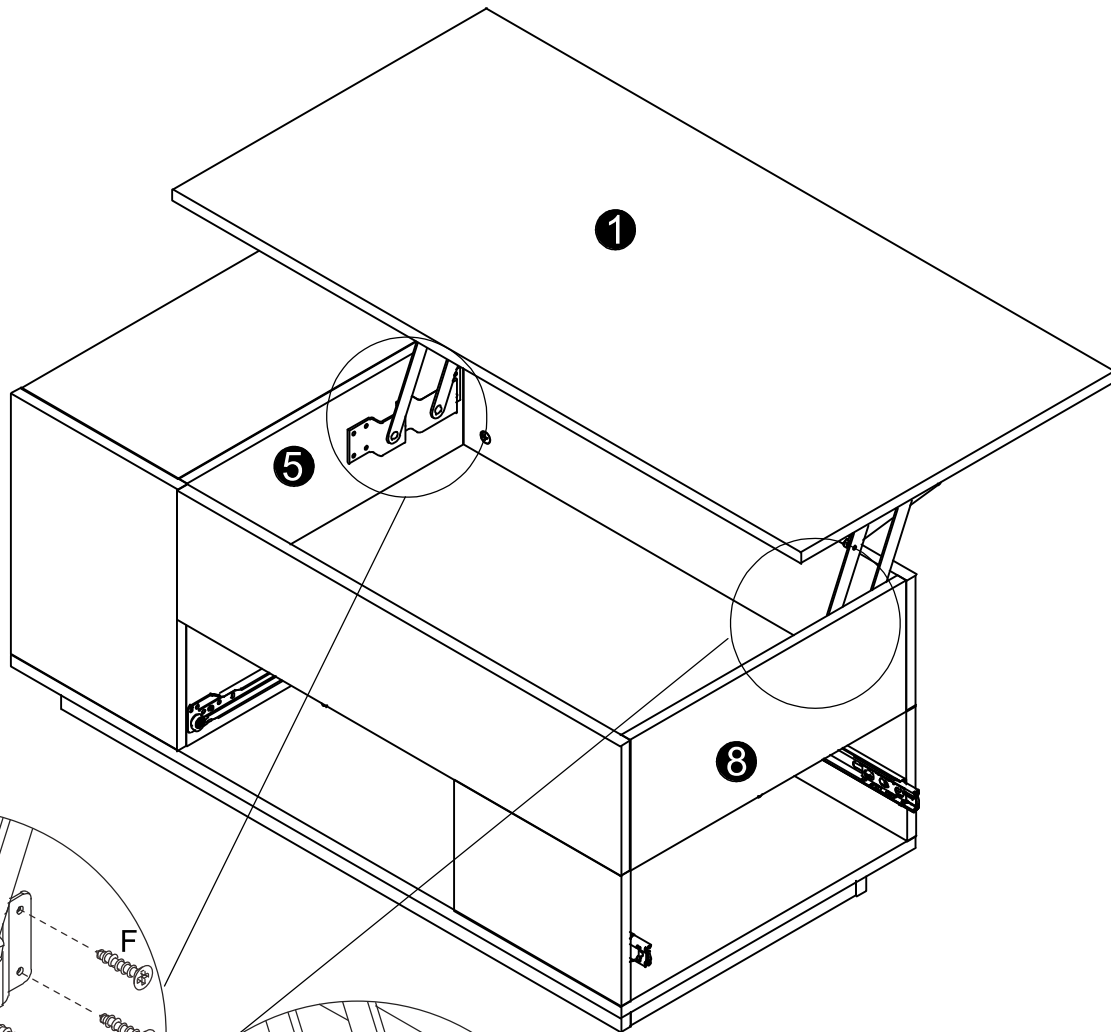



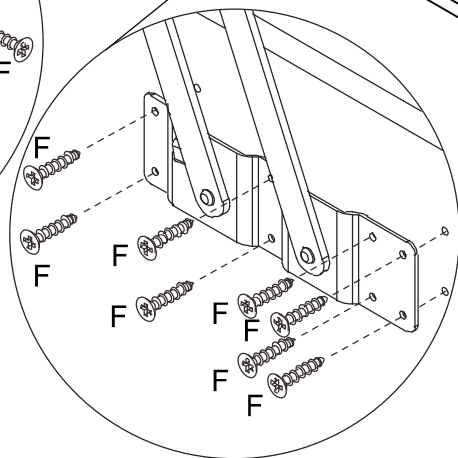
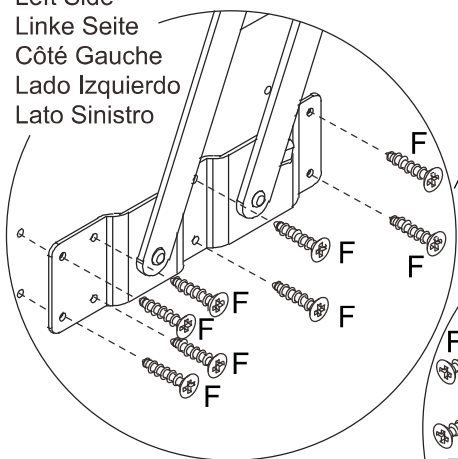

Left Side
Linke Seite
Côté Gauche
Lado Izquierdo
Lato Sinistro



Right Side
Rechte Seite
Côté Droit
Lado Derecho
Lato Destro

21

Ex4  φ3.5*35	Cx4 	G3x1  DL	G4x1  DR	F x4  φ3.5*14
--	---	--	--	--

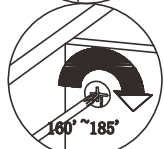
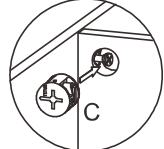
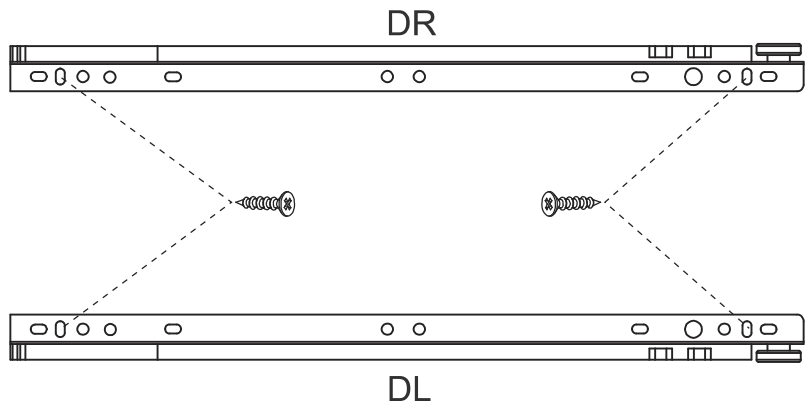
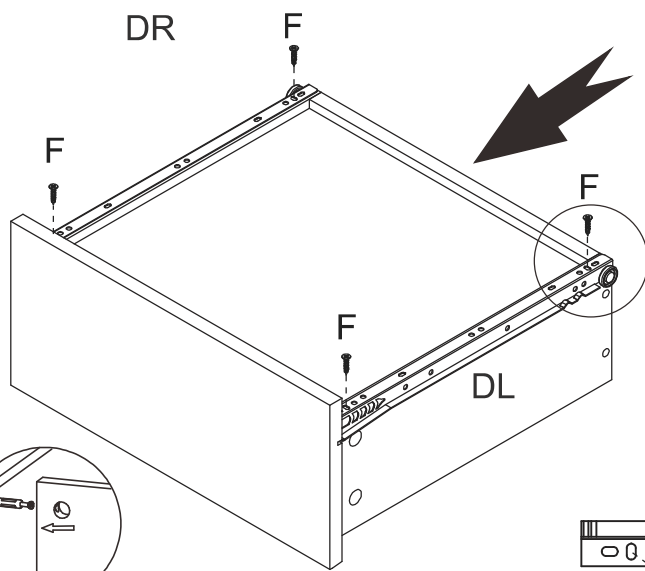
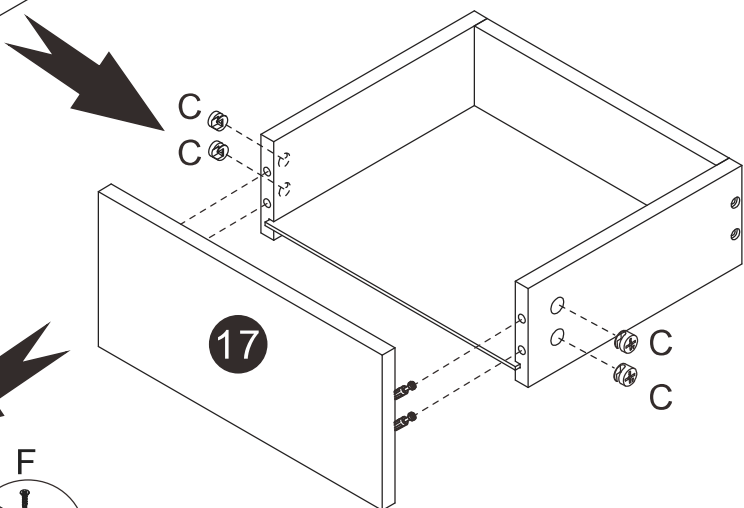
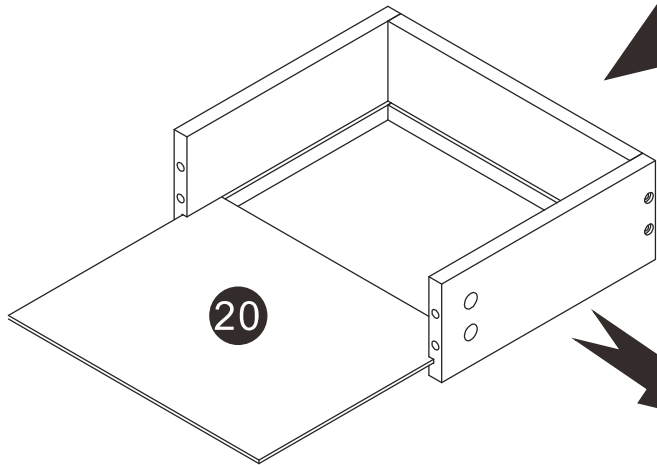
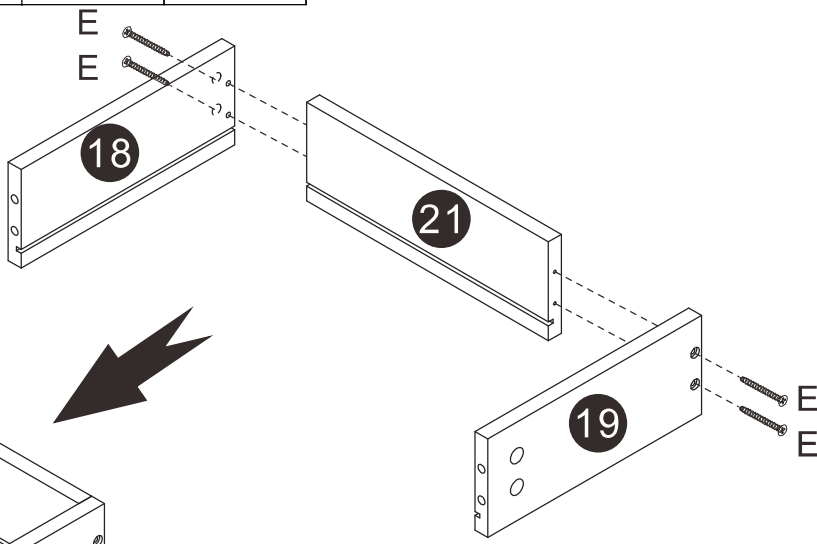

22

Ex4



φ3.5*35

Cx4

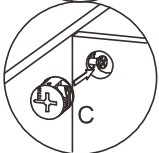
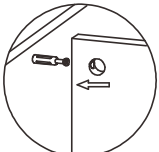
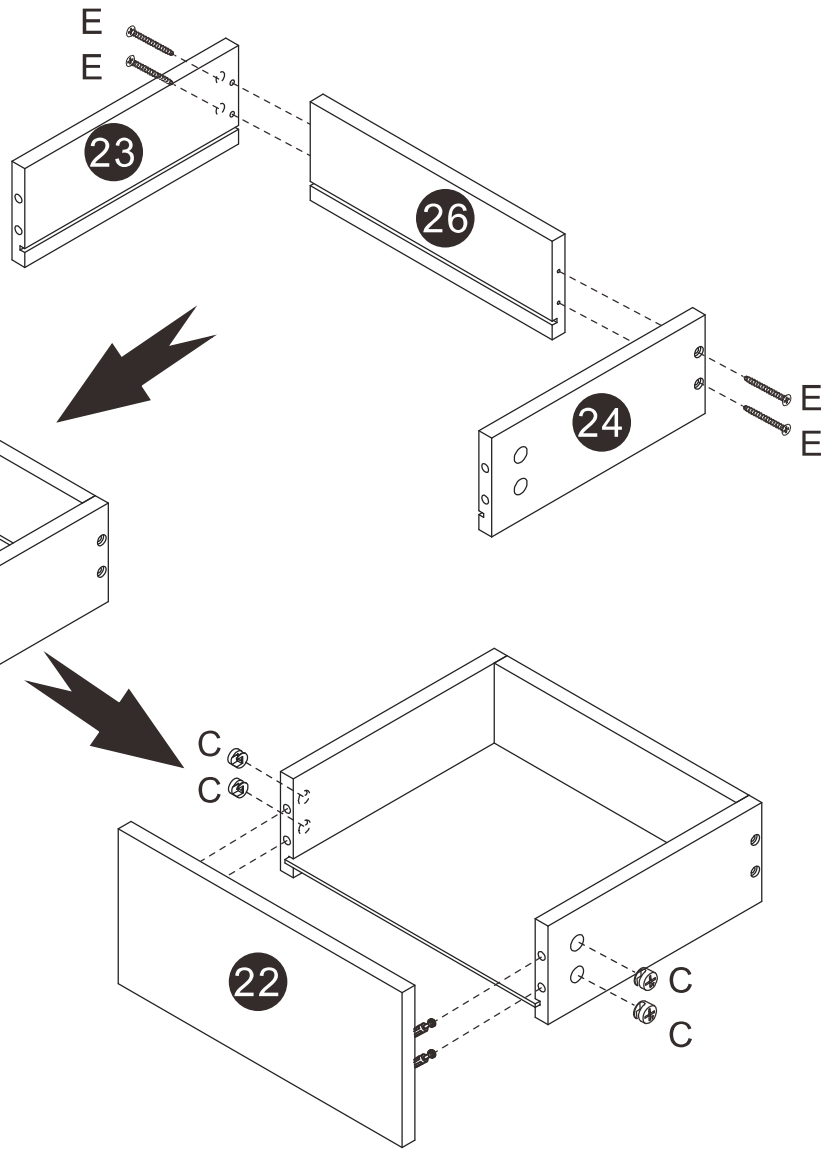

23

Fx4

J2x2



φ3.5*14

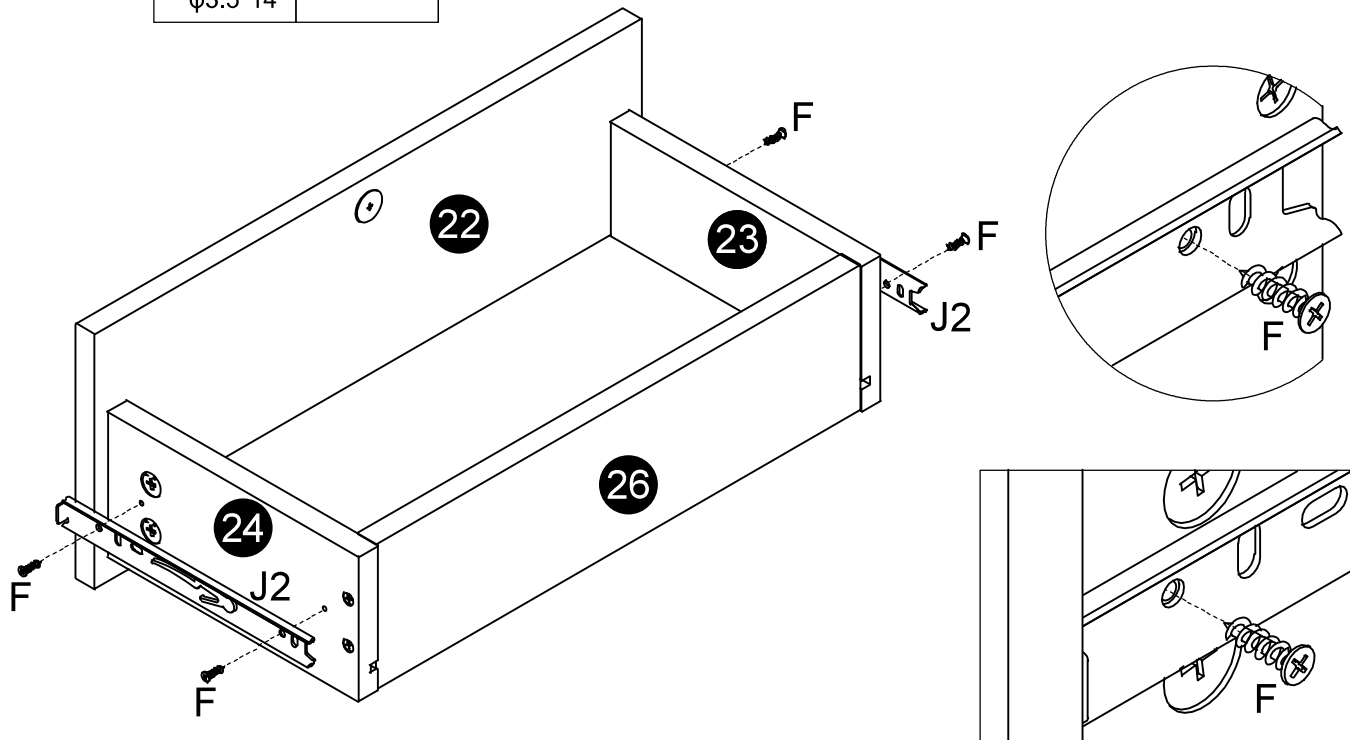

24

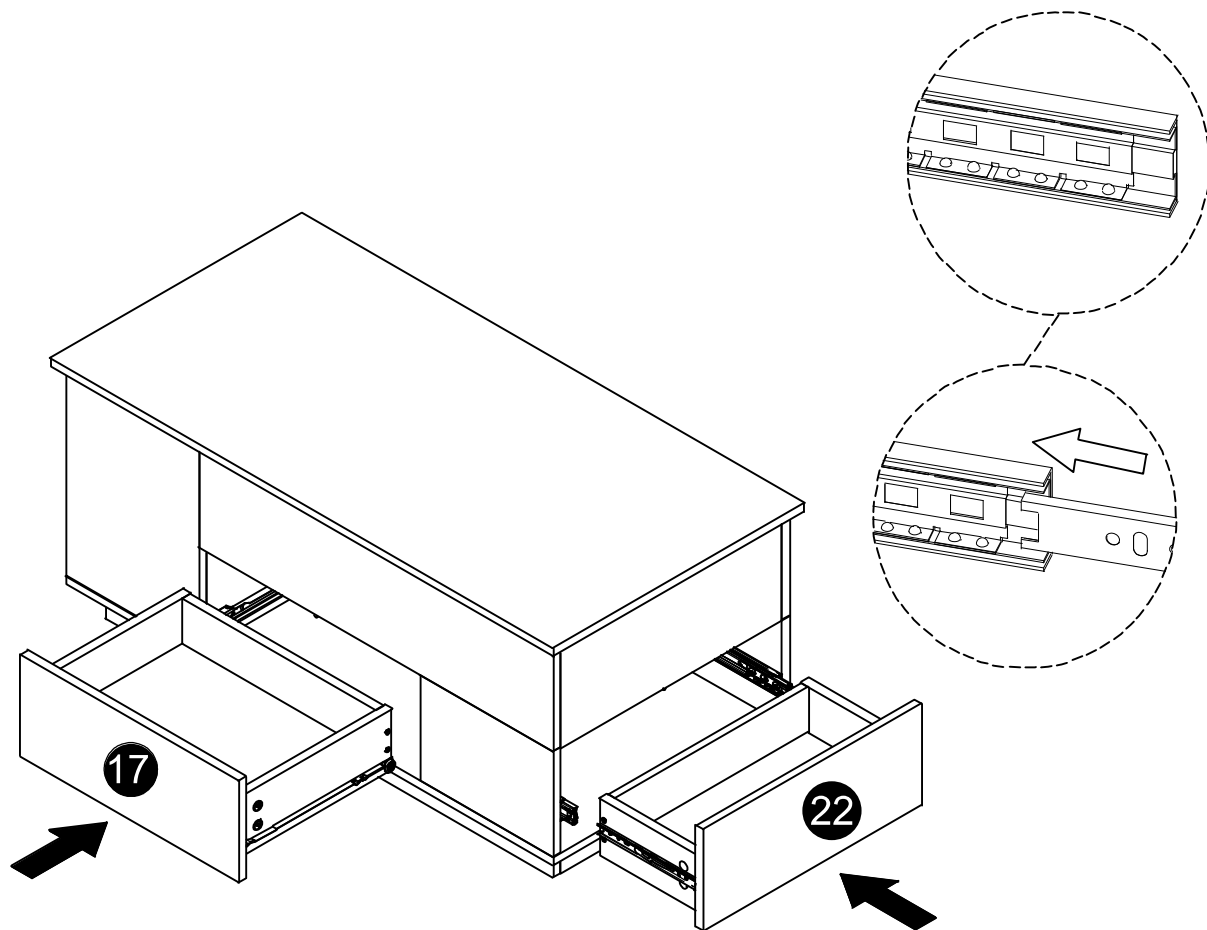

25

Ax24



Px16



$\phi 8 \times 40$

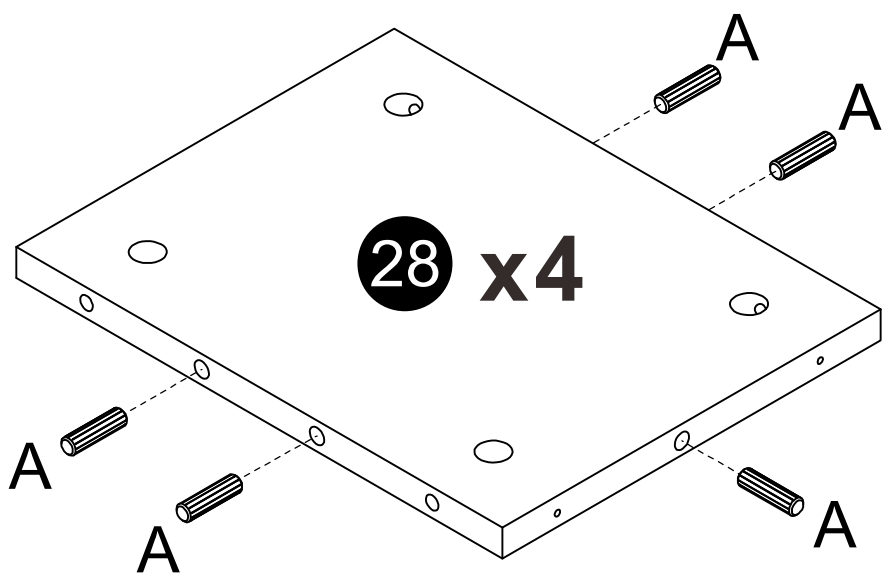
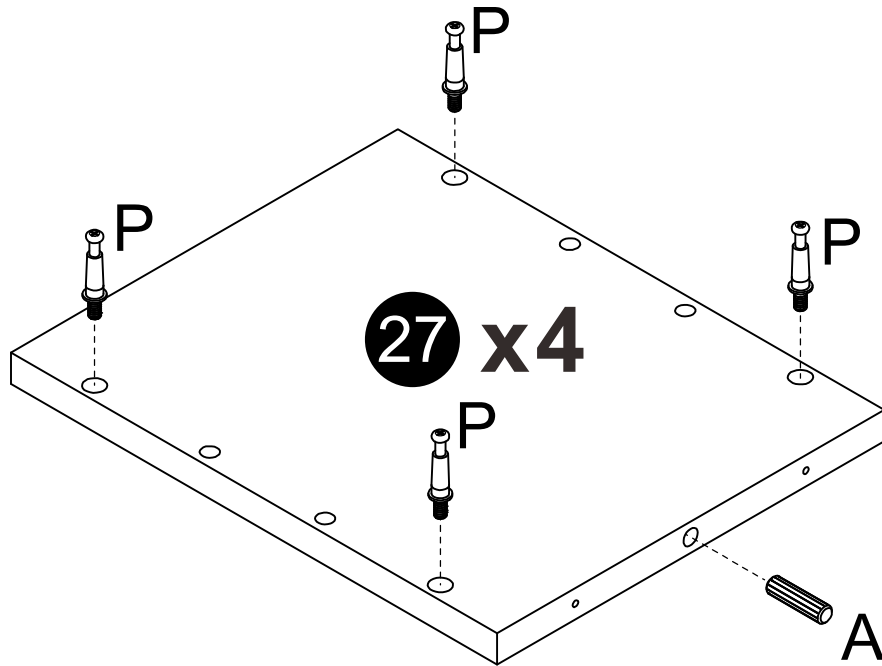

26

Cx16

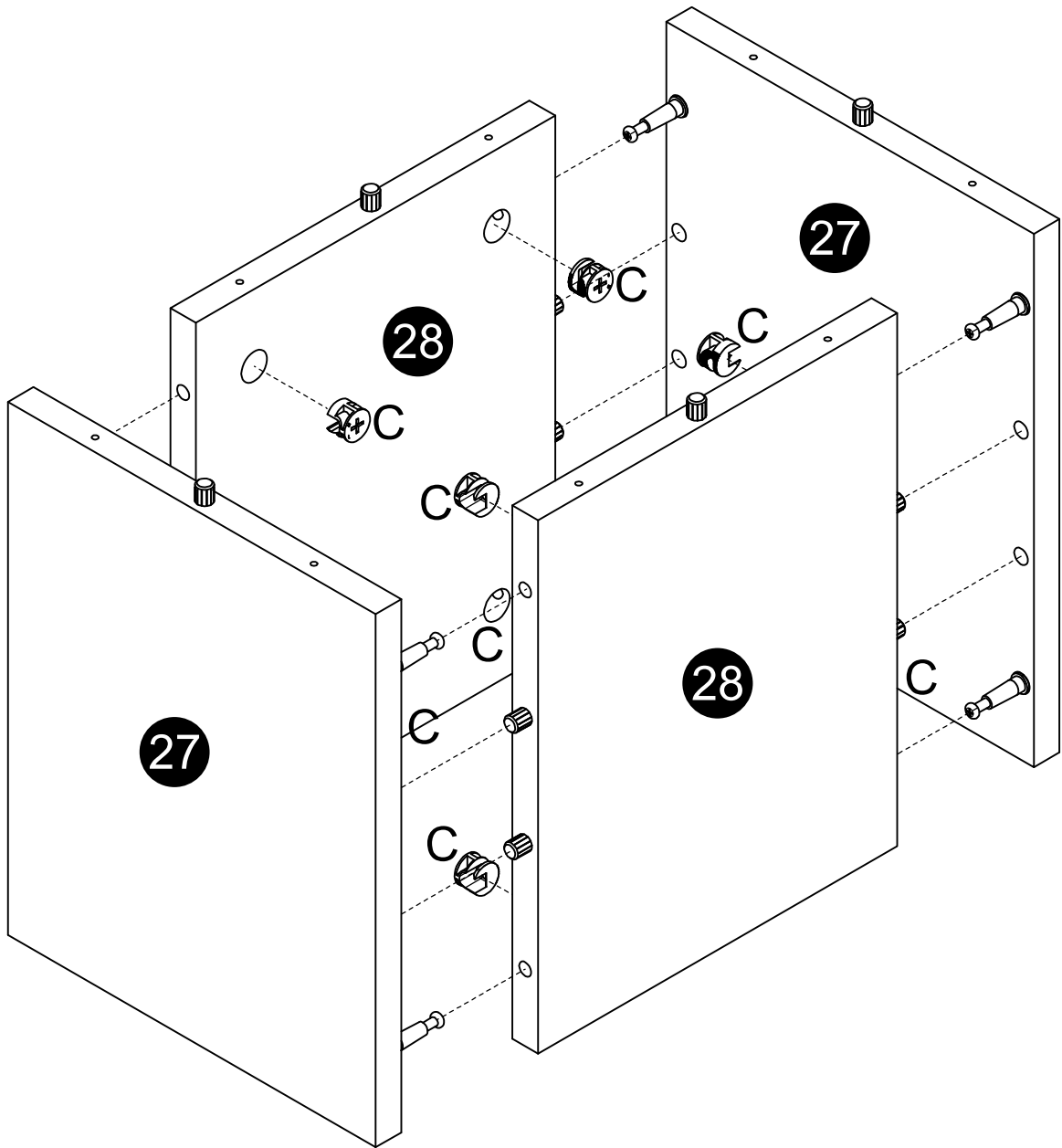

x2

27

Mx16



φ3.5*30

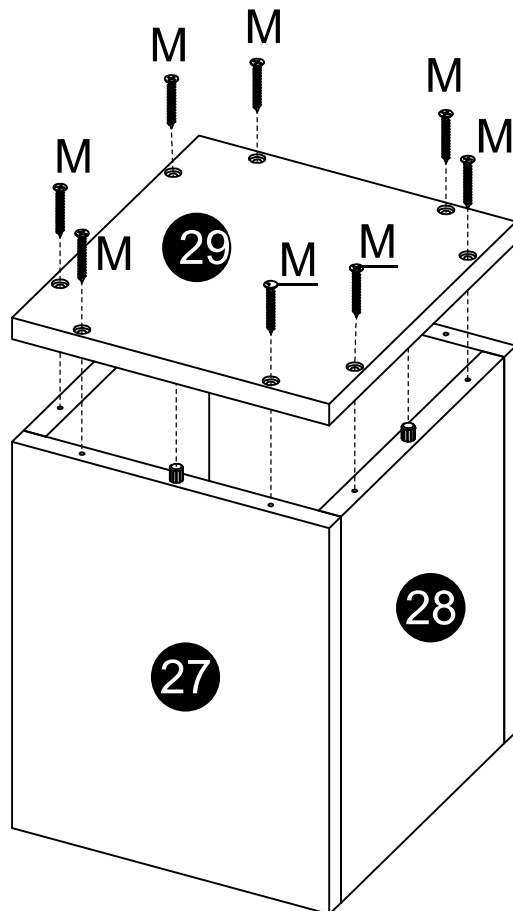

x2

28

Hx8

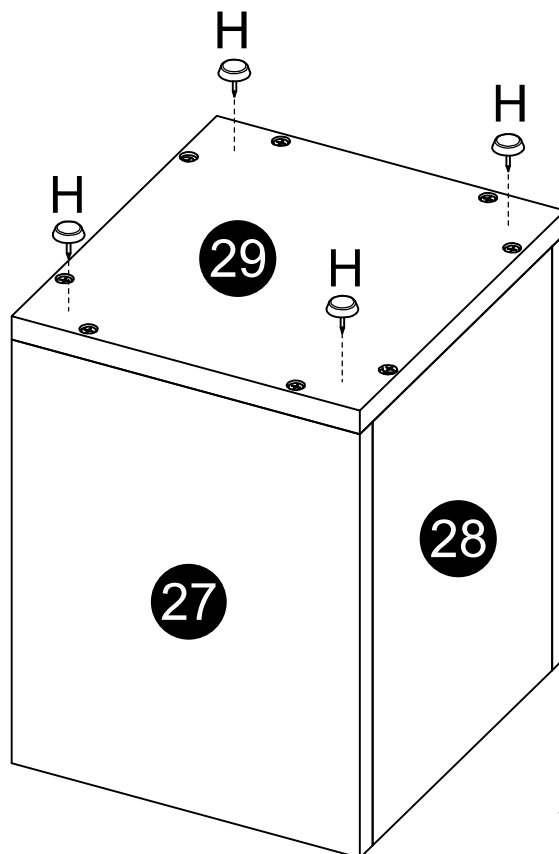

x2

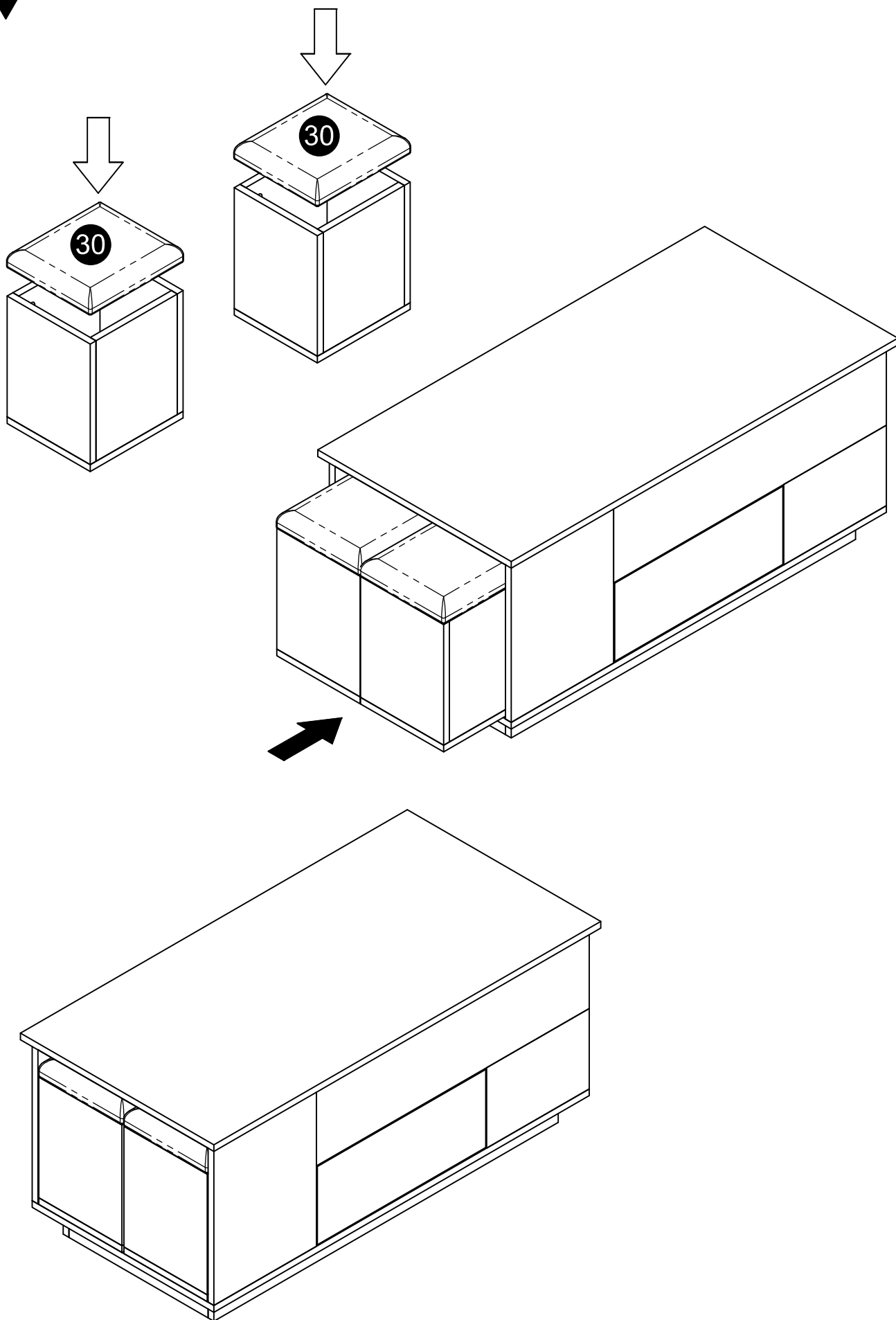

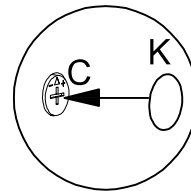
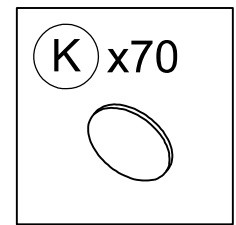
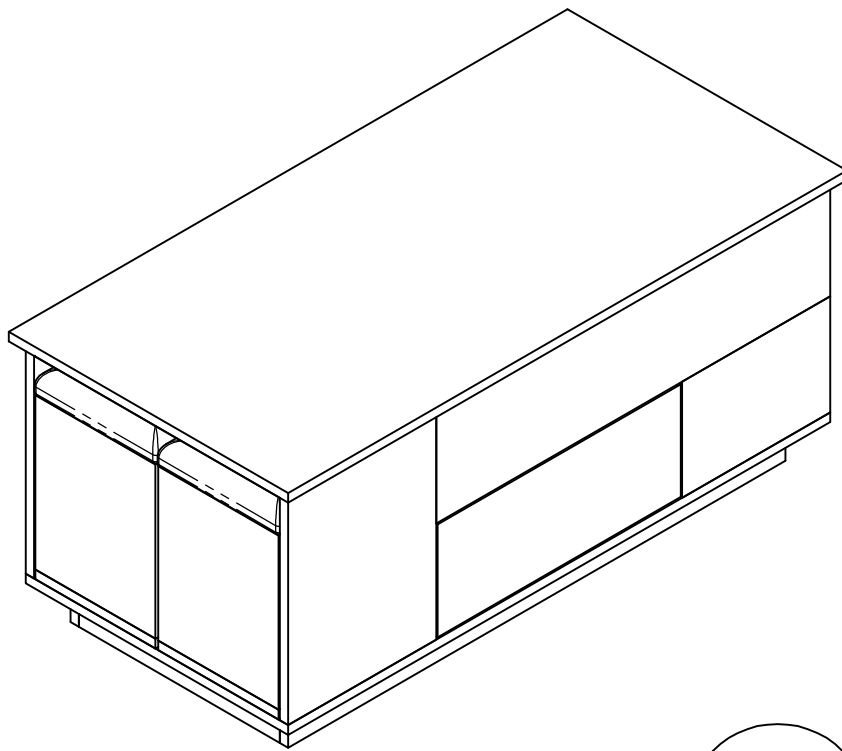

UK: After installing the product, stick the number K on the perforated position

FR: Une fois le produit installé, collez le numéro K à l'endroit où il y a des trous

DE: Nach der Installation des Produkts kleben Sie die Nummer K auf die perforierte Position

IT:Dopo l'installazione del prodotto, fissare il numero K sulla posizione perforata

ES:Después de instalar el producto, pegue el número K en la posición perforada

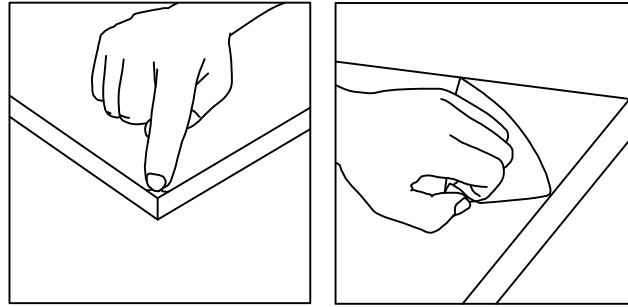

[DE]

BITTE BEACHTEN: Teilenummer 1.8.9.10.11.12.13.14.17.22 ist mit einer dichten Kunststoffschutzfolie überzogen. Wenn das Produkt nach der Demontage Kratzer aufweist, machen Sie sich bitte keine Sorgen, es handelt sich nicht um einen Produktschaden. Bitte ziehen Sie die schützende Kunststoffolie langsam entlang der Kante von der Oberfläche ab. Nach dem Abziehen wird das Produkt glatt und sauber.

[EN]

PLEASE NOTE: Part number 1.8.9.10.11.12.13.14.17.22 are covered with a tight plastic protective film. If there are scratches on the product after disassembly, please don't worry, it's not product damage. Please slowly tear off the protective plastic film on the surface along the edge. After peeling off, the product becomes smooth and clean.

[FR]

REMARQUE : les pièces numéro 1.8.9.10.11.12.13.14.17.22 sont recouvertes d'un film protecteur en plastique étanche. Si le produit présente des rayures après le démontage, ne vous inquiétez pas, il ne s'agit pas d'un dommage au produit. Retirez lentement le film protecteur en plastique sur la surface le long du bord. Une fois décollé, le produit devient lisse et propre.

[IT]

NOTA BENE: il numero di parte 1.8.9.10.11.12.13.14.17.22 è coperto da una pellicola protettiva in plastica stretta. Se ci sono graffi sul prodotto dopo lo smontaggio, non preoccuparti, non è un danno al prodotto. Strappare lentamente la pellicola protettiva in plastica sulla superficie lungo il bordo. Dopo averla staccata, il prodotto diventa liscio e pulito.

[ES]

NOTA: La pieza número 1.8.9.10.11.12.13.14.17.22 está cubierta con una película protectora de plástico. Si hay rayones en el producto después de desmontarlo, no se preocupe, no se trata de daños en el producto. Retire lentamente la película protectora de plástico de la superficie a lo largo del borde. Después de despegarla, el producto quedará liso y limpio.

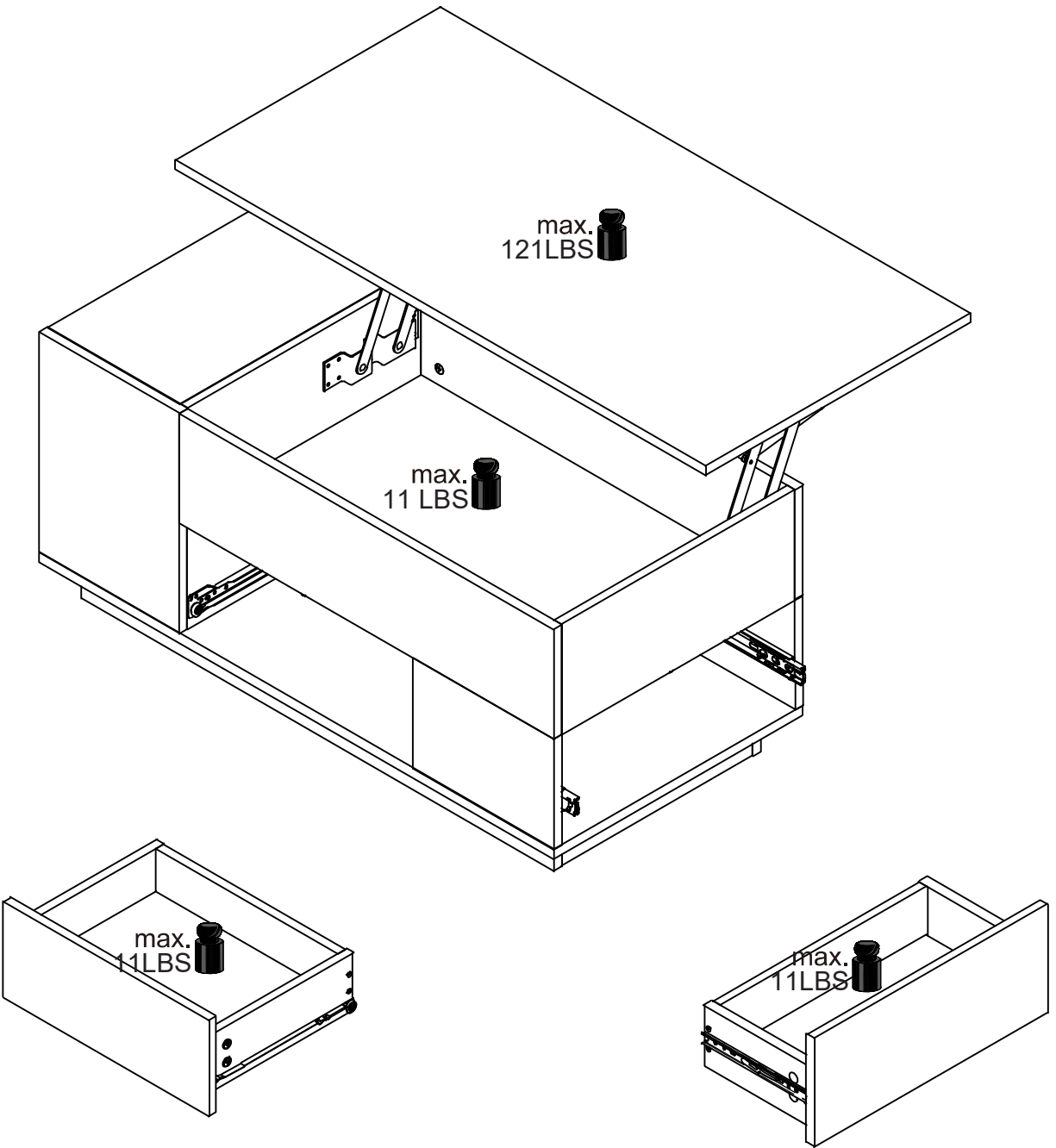

max.
121LBS

max.
11 LBS

max.
11LBS

max.
11LBS

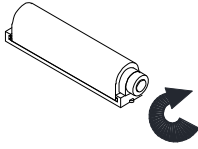

DE: Wenn die Schublade/Tür mit Auslöser (Teil: D) nach außen vorsteht, drehen Sie den Auslöser im Uhrzeigersinn, bis er sanft die Innenseite der Front berührt

FR: Si le tiroir/porte avec loquet (Pièce : D) dépasse vers l'extérieur, tournez le loquet dans le sens horaire jusqu'à ce qu'il touche légèrement l'intérieur du panneau.

EN: If the drawer/door with push-latch (Part: D) protrudes outward rotate the latch clockwise until it gently touches the inner side of the panel

IT: Se la cassetta/anta con dispositivo (Parte: D) sporge verso l'esterno, ruotare il dispositivo in senso orario finché non tocca leggermente la parte interna del pannello

ES: Si el cajón/puerta con mecanismo de retroceso (Pieza: D), sobresale hacia afuera, gire el mecanismo en sentido horario hasta que toque suavemente el interior del panel.

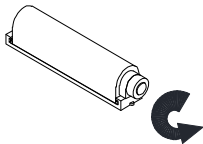

DE: Wenn die Schublade/Tür mit Auslöser (Teil: D) nach innen versenkt ist, drehen Sie den Auslöser gegen den Uhrzeigersinn, bis er sanft die Innenseite der Front berührt.

FR: Si le tiroir/porte avec loquet (Pièce : D) est enfoncé vers l'intérieur, tournez le loquet dans le sens antihoraire jusqu'à ce qu'il touche légèrement l'intérieur du panneau.

EN: If the drawer/door with push-latch (Part: D) is recessed inward, rotate the latch counterclockwise until it gently touches the inner side of the panel

IT: Se la cassetta/anta con dispositivo (Parte: D) è rientrata verso l'interno, ruotare il dispositivo in senso antiorario finché non tocca leggermente la parte interna del pannello

ES: Si el cajón/puerta con mecanismo de retroceso (Pieza: D) está hundido hacia adentro, gire el mecanismo en sentido antihorario hasta que toque suavemente el interior del panel.

APP-PROGRAMMANWENDUNG



VERBINDUNGSSCHRITTE

- LED-Farbstreifen & Controller verbinden, Controller einschalten

- App starten, Controller suchen & verbinden
- Bluetooth-Drahtlossteuerung genießen

PRODUKTMERKMALE

- Direkte Handy-Steuerung (20m Reichweite)
- Automatische Verbindung in 5 Sekunden
- Musikrhythmus-Synchronisation
- Gruppensteuerung
- Helligkeits-/Geschwindigkeitsregelung
- Unterstützt bis 10m RGB(W)-Streifen
- Automatische Sprachumschaltung (DE/EN)



HINWEIS:

Detaillierte Anleitung im Menü "Guide"

PRODUKTPARAMETER

- Bluetooth: BLEVA 2
- Eingangsspannung: 4.5~26V
- Betriebstemperatur: -25~75 ° C
- Abmessungen: 43×22×11 mm
- Gewicht: 30g
- Max. Leistung: 144W (24V)

ANIMATIONEFFEKTE

- Farbverläufe
- Einfarbige/ Zweifarbige Gradienten
- Monochrome/Bunte Blinkereffekte
- Farbspringen
- Musikresponsive Effekte

APP PROGRAM USAGE



Click to show the lamp list

Switch the color wheel

Click to display settings view

Adjust the color

Click square icon to adjust the color

Click to shift the interface

-Connect LED color strip and controller, power on controller

-Start APP, search and connect controller

-Enjoy the Bluetooth wireless control experience



Notes:
detailed operating instructions,
enter the menu "Guide":

Product Parameters:
-Bluetooth:BLEV4.2
-Input Voltage:4.5~26V
-Working Temp:-25~75°C
-Size:43*22*11mm
-Weight:30g
-Max Power:144W(24V)

LED mobile phone Bluetooth controllerProduct Features

- LED Bluetooth controller is directly via mobilephone control remote distance can reach 20m without the need to setupeasy to connect open the software within 5 seconds you can automatically connect the controller
- Flow the rhythm of the music changes
- Group control
- Brightness,speed addition and subtraction
- Maximum can be 10 meters RGB(W)strip
- The software shows that the text is based onthe language of the mobile phone set up automatic transformation of Chinese and English

ANIMATION EFFECTS:

- Colorful gradient
- All kinds of monochrome,double color gradient
- All kinds of monochrome,double color,colorfull flashing
- Colorful jump
- Follow the thymth of the music chagnes

APP-PROGRAMMANWENDUNG

Afficher la
liste des lampes
Farbrad
Changer la
Roue chromatique

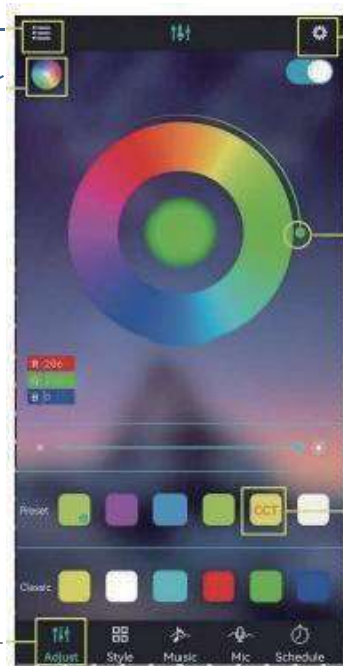

Afficher les
paramètres

Ajuster la couleur

Cliquez sur l'icône
carrée pour ajuster
la couleur.
connecter

Changer d'
interface
par clic

ÉTAPES DE CONNEXION

-Connecter bande LED & contrôleur, allumer

-Lancer l'app, rechercher &

-Profiter du contrôle Bluetooth sans fil

FONCTIONNALITÉS

- Contrôle direct par smartphone (20m)
- Connexion automatique en 5 secondes
- Synchronisation musicale
- Contrôle de groupe
- Réglage luminosité/vitesse
- Prise en charge bandes $\leq 10m$ RGB(W)
- Basculage automatique FR/EN



REMARQUE :

Guide détaillé dans le menu
"Guide"

CARACTÉRISTIQUES

- Bluetooth : BLEVA 2
- Tension d'entrée : 4.5~26V
- Température : -25~75° C
- Dimensions : 43×22×11 mm
- Poids : 30g
- Puissance max : 144W (24V)

EFFETS D'ANIMATION

- Dégradés de couleurs
- Dégradés uni/bicolores
- Clignotements mono/colorés
- Saut de couleurs
- Effets réactifs à la musique

UTILIZZO APP



PASSI CONNESSIONE

-Collega striscia LED & controller, accendi

-Avvia APP, cerca & connetti controller
-Goditi controllo wireless Bluetooth



NOTA:

Guida completa nel menu "Guide"

SPECIFICHE:

- Bluetooth: BLEVA 2
- Tensione ingresso: 4.5~26V
- Temperatura: -25~75° C
- Dimensioni: 43×22×11 mm
- Peso: 30g
- Potenza max: 144W (24V)

CARATTERISTICHE

- Controllo diretto smartphone (20m)
- Connessione automatica in 5 secondi
- Sincronizzazione ritmo musicale
- Controllo di gruppo
- Regolazione luminosità/velocità
- Supporto strisce ≤10m RGB(W)
- Auto switch IT/EN

EFFETTI ANIMAZIONE:

- Sfumature colore
- Gradienti mono/bicolori
- Luci lampeggianti mono/colorate
- Salto colori
- Effetti reattivi alla musica

USO DE LA APLICACIÓN

Mostrar lista de _____
Lámparas
Cambiar rueda de color _____

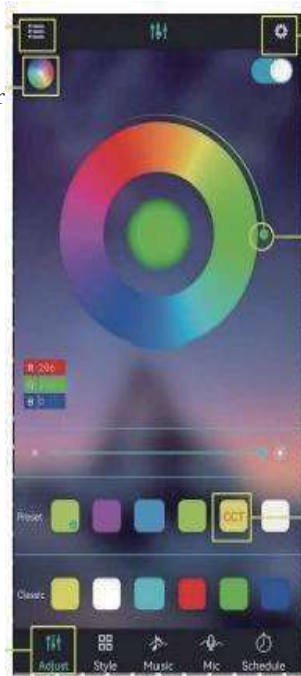

Ver ajustes

Ajustar el color

Clic Ajustar color
con icono cuadrado

Cambiar interfaz
haciendo clic _____

PASOS DE CONEXIÓN

-Conectar tira LED y controlador, encender

-Iniciar APP, buscar y conectar

-Disfrutar control inalámbrico Bluetooth



NOTA:

Guía completa en menú "Guide"

ESPECIFICACIONES:

- Bluetooth: BLEVA 2
- Voltaje entrada: 4.5~26V
- Temperatura: -25~75° C
- Tamaño: 43×22×11 mm
- Peso: 30g
- Potencia máx: 144W (24V)

CARACTERÍSTICAS

- Control directo móvil (20m alcance)
- Conexión automática en 5 segundos
- Sincronización ritmo musical
- Control grupal
- Ajuste brillo/velocidad
- Soporte tiras ≤10m RGB(W)
- Auto cambio ES/EN

EFFECTOS DE ANIMACIÓN:

- Degradados de color
- Transiciones mono/bicolores
- Destellos monocromáticos/color
- Salto de colores
- Efectos reactivos a música